

POWER MANAGEMENT

Features

- Input Voltage as low as 1.6V
- 500mV dropout @ 2A
- Adjustable output from 0.8V
- Over current and over temperature protection
- Enable pin
- 10µA quiescent current in shutdown
- Full industrial temperature range
- Available in SOIC-8-EDP Pb-Free product. RoHS/WEEE and Halogen Free compliant

Applications

- Telecom/Networking cards
- Motherboards/Peripheral cards
- Industrial applications
- Wireless infrastructure
- Set top boxes
- Medical equipment
- Notebook computers
- Battery powered systems

Description

The SC4215 is a high performance positive voltage regulator designed for use in applications requiring very low input voltage and very low dropout voltage at up to 2 amperes. It operates with a V_{in} as low as 1.6V, with output voltage programmable as low as 0.8V. The SC4215 features ultra low dropout, ideal for applications where V_{out} is very close to V_{in} . Additionally, the SC4215 has an enable pin to further reduce power dissipation while shut down. The SC4215 provides excellent regulation over variations in line, load and temperature.

The SC4215 is available in the SOIC-8-EDP (Exposed Die Pad) package. The output voltage can be set via an external divider or to fixed settings of 0.8V and 2.5V depending on how the ADJ pin is configured.

Typical Application Circuit

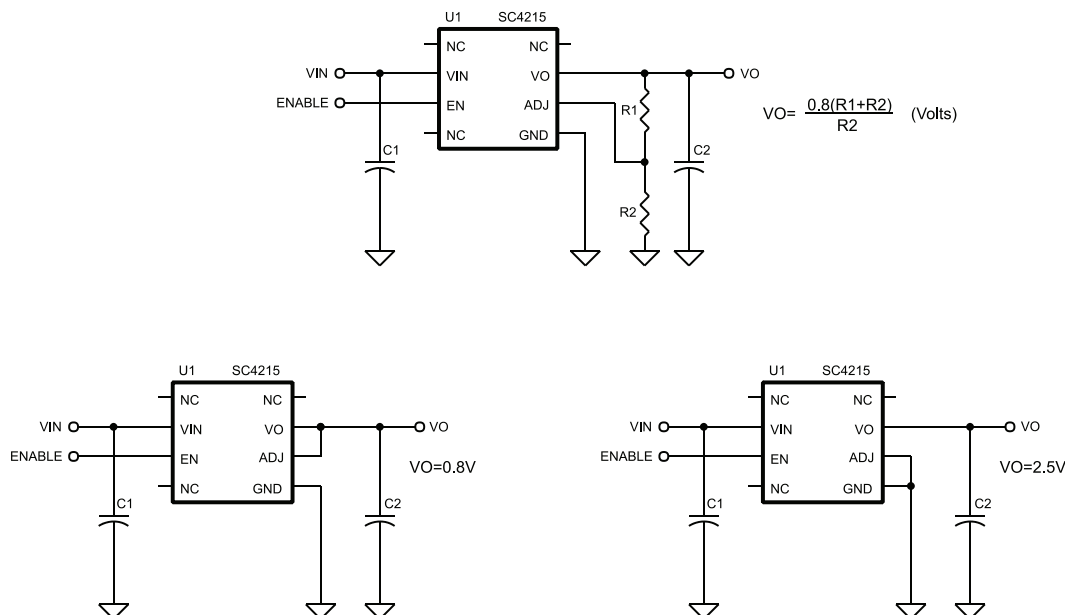

Pin Configuration

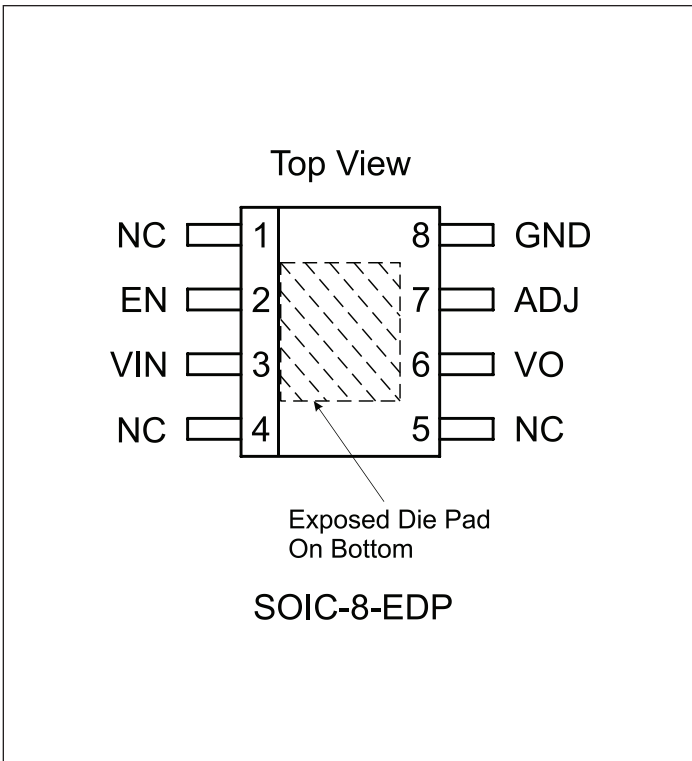

Ordering Information

| Device | Package |
|------------------------------|------------------|
| SC4215ISTR ⁽¹⁾⁽²⁾ | SOIC-8-EDP |
| SC4215IEVB | Evaluation Board |

Notes:

- (1) Available in tape and reel only. A reel contains 2,500 devices.
- (2) Available in Pb-Free product only. RoHS/WEEE and Halogen Free compliant.

Marking Information

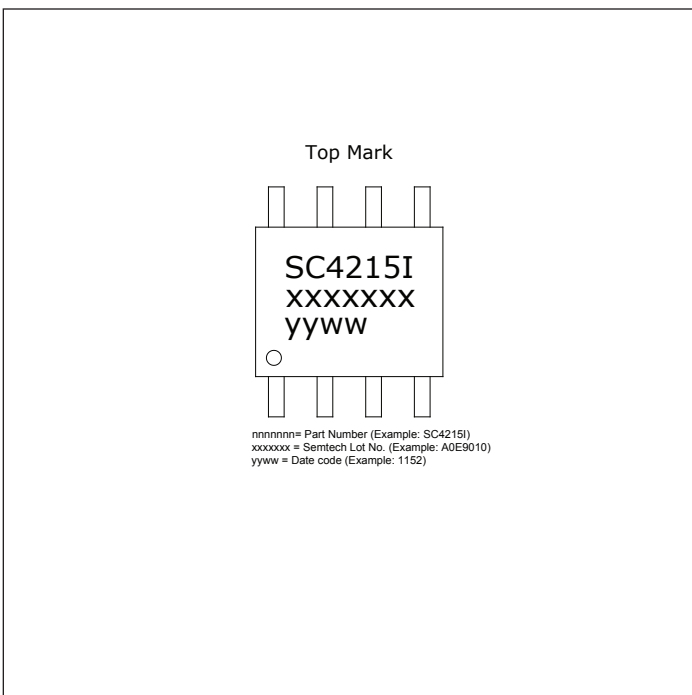

Absolute Maximum Ratings

| | |
|--|--------------------|
| VIN, EN, VO, ADJ to GND (V) | -0.3 to +7.0 |
| Power Dissipation..... | Internally Limited |
| ESD Protection Level ⁽¹⁾ (kV) | 2 |

Recommended Operating Conditions

| | |
|--------------------------------------|----------------------------|
| VIN (V) | $1.6 \leq V_{IN} \leq 5.5$ |
| Ambient Temperature Range (°C)..... | $-40 \leq T_A \leq +85$ |
| Junction Temperature Range (°C)..... | $-40 \leq T_J \leq +125$ |
| Maximum Output Current (A) | 2 |

Thermal Information

| | |
|--|-------------|
| Thermal Resistance, Junction to Ambient ⁽²⁾ (°C/W) | 36 |
| Thermal Resistance, Junction to Case ⁽²⁾ (°C/W)..... | 5.5 |
| Maximum Junction Temperature (°C) | +150 |
| Storage Temperature Range (°C) | -65 to +150 |
| Peak IR Reflow Temperature (10s to 30s) (°C) | +260 |

Exceeding the above specifications may result in permanent damage to the device or device malfunction. Operation outside of the parameters specified in the Electrical Characteristics section is not recommended.

NOTES:

- (1) Tested according to JEDEC standard JESD22-A114-B.
- (2) Calculated from package in still air, mounted to 3" x 4.5", 4 layer FR4 PCB with thermal vias under the exposed pad per JESD51 standards.

Electrical Characteristics

Unless specified: $V_{EN} = V_{IN}$, $V_{IN} = 1.6V$ to $5.5V$, $I_O = 10\mu A$ to $2A$, $T_A = 25^\circ C$.
 Values in **bold** apply over the full operating temperature range.

| Parameter | Symbol | Conditions | Min | Typ | Max | Units |
|---------------------------------|----------------|---|------------|-------|-------------|---------|
| VIN | | | | | | |
| Quiescent Current | I_Q | $V_{IN} = 3.3V, I_O = 0A$ | | 0.75 | 1.75 | mA |
| | | $V_{IN} = 5.5V, V_{EN} = 0V$ | | 10 | 50 | μA |
| VO | | | | | | |
| Output Voltage ⁽¹⁾ | V_O | $V_{IN} = V_O + 0.5V, I_O = 10mA$ | -2% | V_O | +2% | V |
| (Fixed Voltage, $V_{ADJ} = 0$) | | $1.60V \leq V_{IN} \leq 5.5V, I_O = 10mA$ | -3% | | +3% | |
| Line Regulation ⁽¹⁾ | $REG_{(LINE)}$ | $I_O = 10mA$ | | 0.2 | 0.4 | %/V |
| Load Regulation ⁽¹⁾ | $REG_{(LOAD)}$ | $I_O = 10mA$ to $2A$ | | 0.5 | 1.0 | % |

Electrical Characteristics (continued)

| Parameter | Symbol | Conditions | Min | Typ | Max | Units |
|--|-----------------------|---|--------------|------------|--------------|-------------|
| Dropout Voltage ⁽¹⁾⁽²⁾ | V_{DO} | $I_o = 1A$ | | 90 | 300 | mV |
| | | | | | 400 | |
| | | $I_o = 1.5A$ | | 200 | 400 | |
| | | | | | 500 | |
| $I_o = 2A$ | $V_{IN} = V_o + 0.5V$ | | 300 | 500 | | |
| | $V_{IN} = V_o + 0.6V$ | | | 600 | | |
| Minimum Load Current ⁽³⁾⁽⁴⁾ | I_o | $V_{IN} = V_o + 0.5V$ | | 1 | 10 | μA |
| Current Limit ⁽⁴⁾ | I_{CL} | | 2.2 | 3 | 4.5 | A |
| ADJ | | | | | | |
| Reference Voltage ⁽¹⁾ | V_{REF} | $V_{IN} = 3.3V, V_{FB} = V_{OUT}, I_o = 10mA$ | 0.792 | 0.8 | 0.808 | V |
| | | | 0.784 | | 0.816 | |
| Adjust Pin Current ⁽⁴⁾ | I_{ADJ} | $V_{ADJ} = V_{REF}$ | | 80 | 200 | nA |
| Adjust Pin Threshold ⁽⁵⁾ | $V_{TH(ADJ)}$ | | 0.05 | 0.16 | 0.40 | V |
| EN | | | | | | |
| Enable Pin Current | I_{EN} | $V_{EN} = 0V, V_{IN} = 3.3V$ | | 1.5 | 10 | μA |
| Enable Pin Threshold | V_{IH} | $V_{IN} = 3.3V$ | 1.6 | | | V |
| | V_{IL} | | | | 0.4 | |
| Over Temperature Protection | | | | | | |
| High Trip Level | T_{HI} | | | 160 | | $^{\circ}C$ |
| Hysteresis | T_{HYST} | | | 10 | | $^{\circ}C$ |

Notes:

(1) Low duty cycle pulse testing with Kelvin connections required.

 (2) $V_{DO} = V_{IN} - V_o$ when V_o decreases by 1.5% of its nominal output voltage.

(3) Required to maintain regulation. Voltage set resistors R1 and R2 are usually utilized to meet this requirement. Adjustable mode only.

(4) Guaranteed by design.

 (5) When V_{ADJ} exceeds this threshold, the "Sense Select" switch disconnects the internal feedback chain from the error amplifier and connects V_{ADJ} instead.

Typical Characteristics

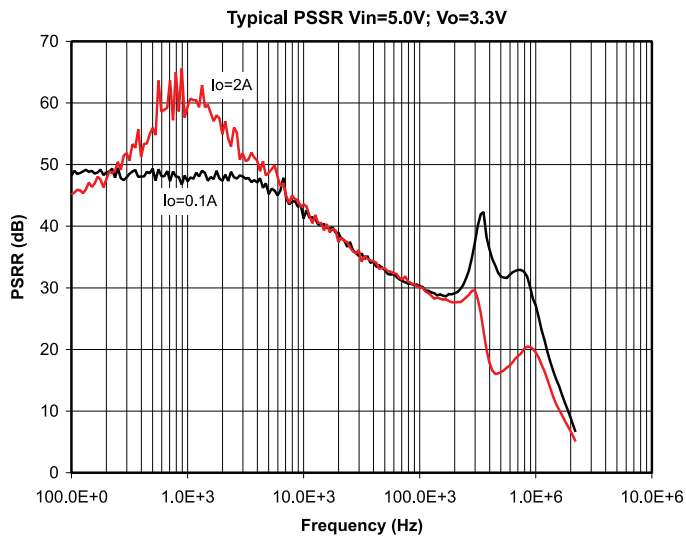
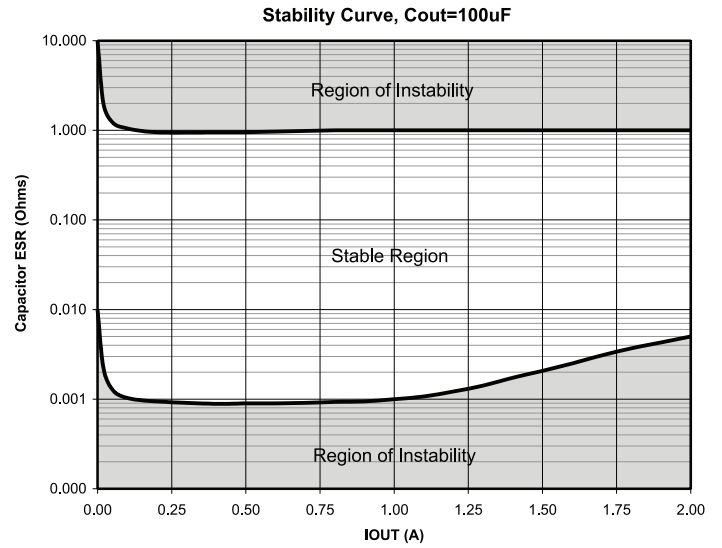
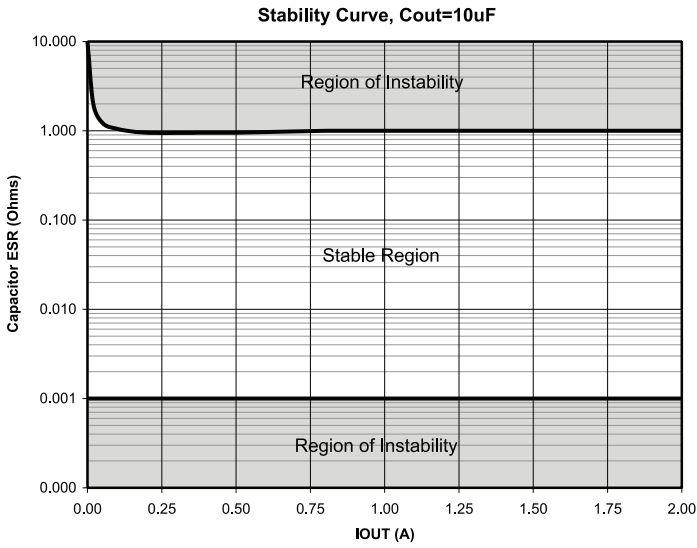

Pin Descriptions

| Pin # | Pin Name | Pin Function |
|---------|-------------|--|
| 2 | EN | Enable Input. Pulling this pin below 0.4V turns the regulator off, reducing the quiescent current to a fraction of its operating value. The device will be enabled if this pin is left open. Connect to VIN if not being used. |
| 3 | VIN | Input voltage. For regulation at full load, the input to this pin must be between (VO+ 0.5V) and 5.5V. Minimum VIN = 1.6V. A large bulk capacitance should be placed closely to this pin to ensure that the input supply does not sag below 1.6V. Also a minimum of 4.7uF ceramic capacitor should be placed directly at this pin. |
| 6 | VO | The pin is the power output of the device. A minimum of 10uF capacitor should be placed directly at this pin. |
| 7 | ADJ | When this pin is grounded, an internal resistor divider sets the output voltage to 2.5V. If connected to the Vo pin, the output voltage will be set at 0.8V. If external feedback resistors are used, the output voltage will be determined by the resistor ratio (See Application Circuits on page 1): |
| 8 | GND | Reference ground. The GND pin and the exposed die pad must be connected together at the IC pin. |
| 1, 4, 5 | NC | No Connection. |
| | THERMAL PAD | Pad for heatsinking purposes. Connect to ground plane using multiple vias. |

Block Diagram

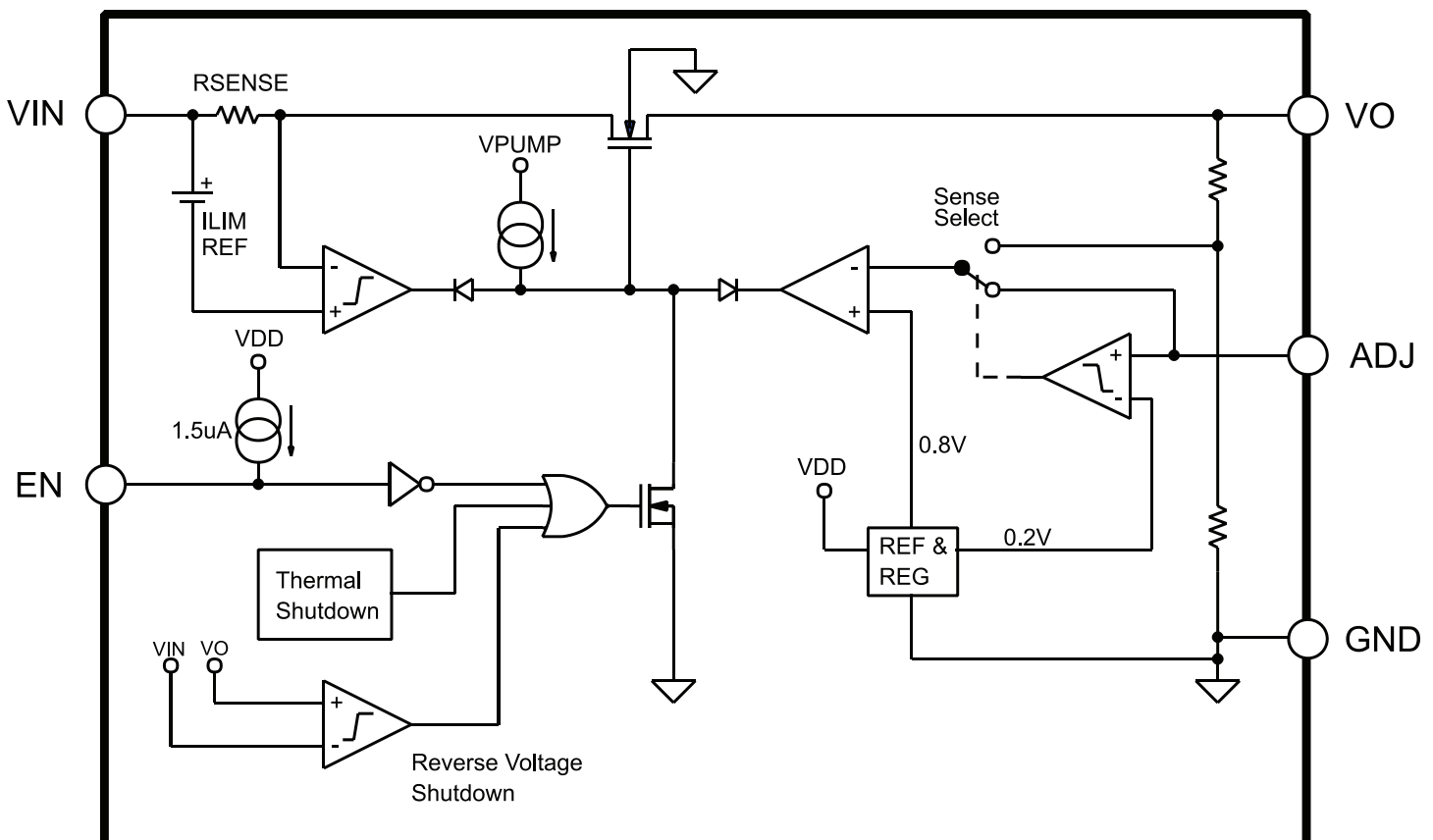

Applications Information (continued)

Introduction

The SC4215 is intended for applications where high current capability and very low dropout voltage are required. It provides a very simple, low cost solution that uses very little PCB real estate. Additional features include an enable pin to allow for a very low power consumption standby mode, and a fully adjustable output.

Component Selection

Input capacitor: A large bulk capacitance $\geq 10\mu\text{F/A}$ (output load) should be closely placed to the input supply pin of the SC4215 to ensure that V_{in} does not sag below 1.4V. Also a minimum of 4.7 μF ceramic capacitor is recommended to be placed directly next to the V_{in} pin. This allows for the device being some distance from any bulk capacitance on the rail. Additionally, input droop due to load transients is reduced, improving load transient response. Additional capacitance may be added if required by the application.

Output capacitor: A minimum bulk capacitance of $\geq 10\mu\text{F/A}$ (output load), along with a 0.1 μF ceramic decoupling capacitor is recommended. Increasing the bulk capacitance will improve the overall transient response. The use of multiple lower value ceramic capacitors in parallel to achieve the desired bulk capacitance will not cause stability issues. Although designed for use with ceramic output capacitors, the SC4215 is extremely tolerant of output capacitor ESR values and thus will also work comfortably with tantalum output capacitors.

Noise immunity: In very electrically noisy environments, it is recommended that 0.1 μF ceramic capacitors be placed from IN to GND and OUT to GND as close to the device pins as possible.

Internal voltage selection: By connecting the ADJ pin to GND, an internal resistor divider will regulate the output voltage to 2.5V.

If the ADJ pin is connected directly to the VO pin, the output voltage will be regulated to the 0.8V internal reference.

External voltage selection resistors: The use of 1% resistors, and designing for a current flow $\geq 10\mu\text{A}$ is recommended to ensure a well regulated output (thus R2

$\leq 50\text{k}\Omega$). A suitable value for R2 can be chosen in the range of 1k Ω to 50k Ω . R1 can then be calculated from.

$$R_1 = R_2 \cdot \frac{(V_O - V_{\text{REF}})}{V_{\text{REF}}}$$

Enable: Pulling this pin below 0.4V turns the regulator off, reducing the quiescent current to a fraction of its operating value. A pull up resistor up to 400kOhms should be connected from this pin to the V_{IN} pin in applications where supply voltages of $V_{\text{in}} < 1.9\text{V}$ are required. For applications with higher voltages than 1.9V, EN pin could be left open or connected to V_{IN} .

Thermal Considerations

The power dissipation in the SC4215 is given by:

$$P_D \approx I_O \cdot (V_{\text{IN}} - V_O)$$

The allowable power dissipation will be dependant on the thermal impedance achieved in the application. The derating curve below is valid for the thermal impedance specified in the Thermal Information section on page 3.

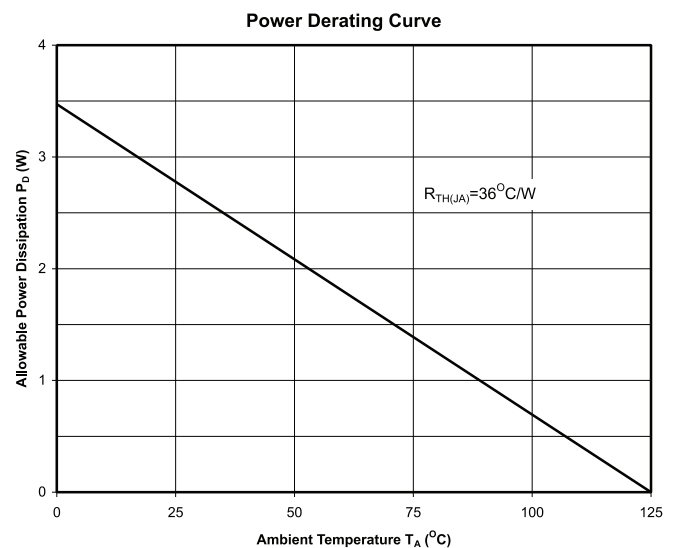

Outline Drawing — SOIC-8-EDP-3

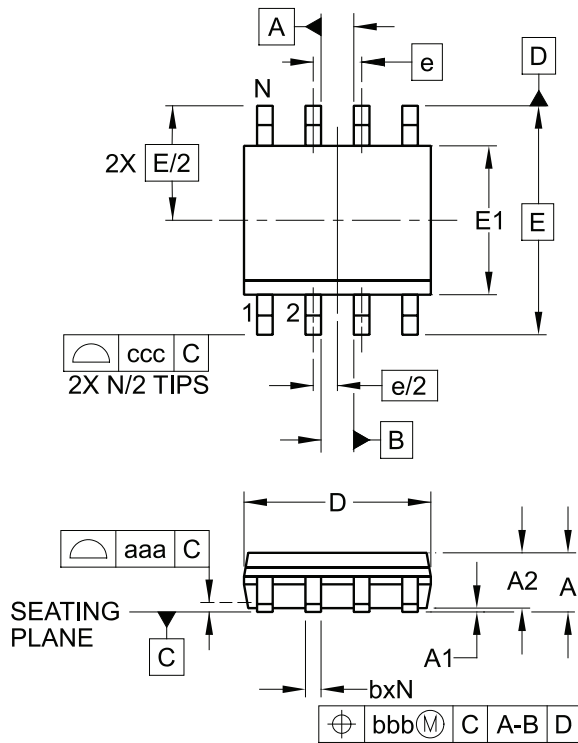

| DIM | INCHES | | | MILLIMETERS | | |
|------------|----------|------|------|-------------|------|------|
| | MIN | NOM | MAX | MIN | NOM | MAX |
| A | .053 | - | .069 | 1.35 | - | 1.75 |
| A1 | .000 | - | .005 | 0.00 | - | 0.13 |
| A2 | .049 | - | .065 | 1.25 | - | 1.65 |
| b | .012 | - | .020 | 0.31 | - | 0.51 |
| c | .007 | - | .010 | 0.17 | - | 0.25 |
| D | .189 | .193 | .197 | 4.80 | 4.90 | 5.00 |
| E1 | .150 | .154 | .157 | 3.80 | 3.90 | 4.00 |
| E | .236 BSC | | | 6.00 BSC | | |
| e | .050 BSC | | | 1.27 BSC | | |
| F | .086 | - | .130 | 2.19 | - | 3.30 |
| H | .085 | - | .099 | 2.15 | - | 2.51 |
| h | .010 | - | .020 | 0.25 | - | 0.50 |
| L | .016 | .028 | .041 | 0.40 | 0.72 | 1.04 |
| L1 | (.041) | | | (1.05) | | |
| N | 8 | | | 8 | | |
| $\theta 1$ | 0° | - | 8° | 0° | - | 8° |
| aaa | .004 | | | 0.10 | | |
| bbb | .010 | | | 0.25 | | |
| ccc | .008 | | | 0.20 | | |

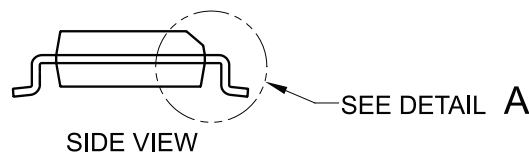
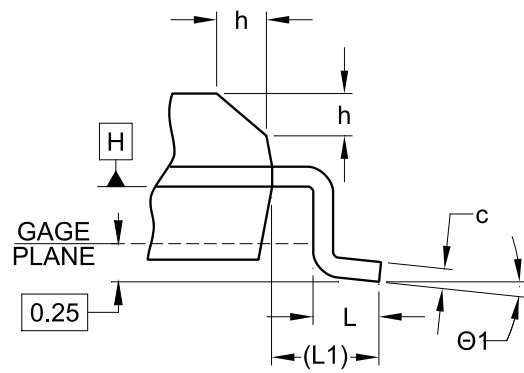
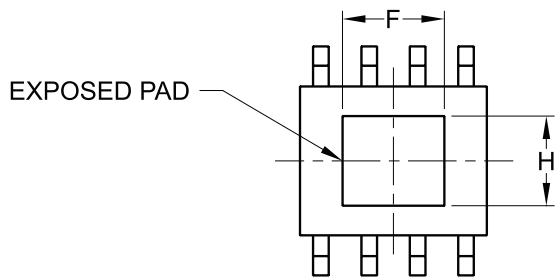

NOTES:

1. CONTROLLING DIMENSIONS ARE IN MILLIMETERS (ANGLES IN DEGREES).
2. DATUMS **-A-** AND **-B-** TO BE DETERMINED AT DATUM PLANE **-H-**
3. DIMENSIONS "E1" AND "D" DO NOT INCLUDE MOLD FLASH, PROTRUSIONS OR GATE BURRS.

Land Pattern — SOIC-8-EDP-3

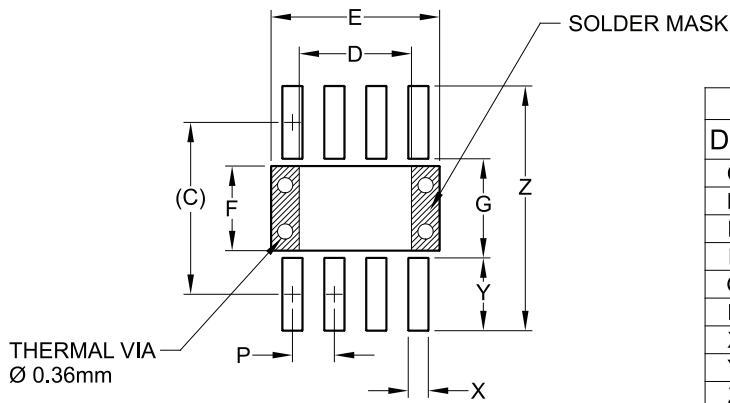

| DIMENSIONS | | |
|------------|--------|-------------|
| DIM | INCHES | MILLIMETERS |
| C | (.205) | (5.20) |
| D | .134 | 3.40 |
| E | .201 | 5.10 |
| F | .101 | 2.56 |
| G | .118 | 3.00 |
| P | .050 | 1.27 |
| X | .024 | 0.60 |
| Y | .087 | 2.20 |
| Z | .291 | 7.40 |

NOTES:

1. CONTROLLING DIMENSIONS ARE IN MILLIMETERS (ANGLES IN DEGREES).
2. THIS LAND PATTERN IS FOR REFERENCE PURPOSES ONLY. CONSULT YOUR MANUFACTURING GROUP TO ENSURE YOUR COMPANY'S MANUFACTURING GUIDELINES ARE MET.
3. REFERENCE IPC-SM-782A, RLP NO. 300A.
4. THERMAL VIAS IN THE LAND PATTERN OF THE EXPOSED PAD SHALL BE CONNECTED TO A SYSTEM GROUND PLANE. FAILURE TO DO SO MAY COMPROMISE THE THERMAL AND/OR FUNCTIONAL PERFORMANCE OF THE DEVICE.

Contact Information

Semtech Corporation
 Power Management Products Division
 200 Flynn Road, Camarillo, CA 93012
 Phone: (805) 498-2111 Fax: (805) 498-3804

www.semtech.com

X-ON Electronics

Largest Supplier of Electrical and Electronic Components

Click to view similar products for [LDO Voltage Regulators](#) category:

Click to view products by [Semtech](#) manufacturer:

Other Similar products are found below :

[AP7363-SP-13](#) [L79M05TL-E](#) [PT7M8202B12TA5EX](#) [TCR3DF185,LM\(CT](#) [TCR3DF24,LM\(CT](#) [TCR3DF285,LM\(CT](#) [TCR3DF31,LM\(CT](#)
[TCR3DF45,LM\(CT](#) [MP2013GQ-33-Z](#) [059985X](#) [NCP4687DH15T1G](#) [701326R](#) [TCR2EN28,LF\(S](#) [NCV8170AXV250T2G](#)
[TCR3DF27,LM\(CT](#) [TCR3DF19,LM\(CT](#) [TCR3DF125,LM\(CT](#) [TCR2EN18,LF\(S](#) [AP2112R5A-3.3TRG1](#) [AP7315-25W5-7](#)
[IFX30081LDVGRNXUMA1](#) [NCV47411PAAJR2G](#) [AP2113KTR-G1](#) [AP2111H-1.2TRG1](#) [ZLDO1117QK50TC](#) [AZ1117IH-1.8TRG1](#)
[AZ1117ID-ADJTRG1](#) [TCR3DG12,LF](#) [MIC5514-3.3YMT-T5](#) [MIC5512-1.2YMT-T5](#) [MIC5317-2.8YM5-T5](#) [SCD7912BTG](#)
[NCP154MX180270TAG](#) [SCD33269T-5.0G](#) [NCV8170BMX330TCG](#) [NCV8170AMX120TCG](#) [NCP706ABMX300TAG](#)
[NCP153MX330180TCG](#) [NCP114BMX075TCG](#) [MC33269T-3.5G](#) [CAT6243-ADJCMT5T](#) [TCR3DG33,LF](#) [AP2127N-1.0TRG1](#)
[TCR4DG35,LF](#) [LT1117CST-3.3](#) [TAR5S15U\(TE85L,F\)](#) [TAR5S18U\(TE85L,F\)](#) [TCR3UG19A,LF](#) [TCR4DG105,LF](#) [NCV8170AMX360TCG](#)