

HIGH-RELIABILITY PRODUCTS
Features

- Wide operating current range 130µA to 150mA
- Low dynamic output impedance 0.25Ω typ.
- Trimmed bandgap ± 0.5%
- Alternate for TL1431, TL431, LM431 & AS431
- Military temperature range
- Available in SOT-23-3 package
- Pb-free, Halogen Free, RoHS / WEEE compliant

Applications

- Linear Regulators
- Switching Power Supplies

Description

The SC431M is a three terminal adjustable shunt regulator with thermal stability guaranteed over temperature. The output voltage can be adjusted to any value from 2.5V (V_{REF}) to 30V with two external resistors.

The SC431M has a typical dynamic output impedance of 0.25Ω. Active output circuitry provides a very sharp turn on characteristic, making the SC431M an excellent replacement for Zener diodes.

The SC431M shunt regulator is available with a 0.5% voltage tolerance at room temperature and comes in a SOT-23-3 package.

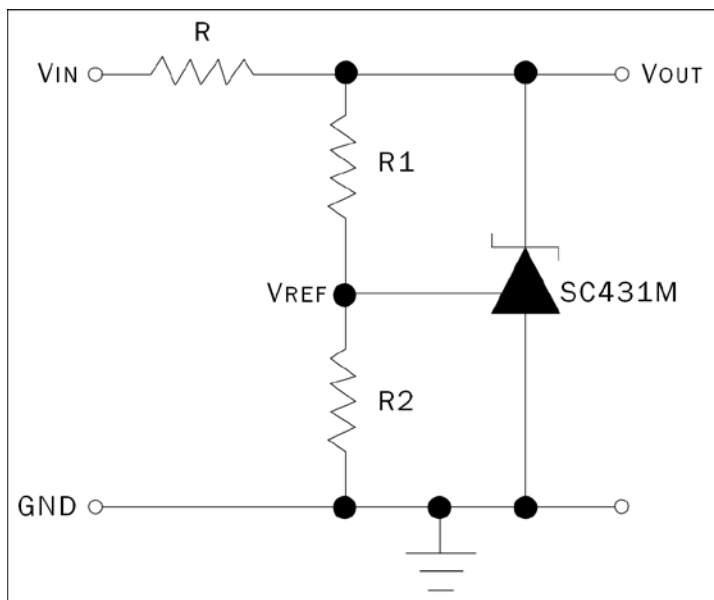
Typical Application Circuit

Notes:

- 1) Set V_{OUT} according to the following equation:

$$V_{OUT} = V_{REF} \left(1 + \frac{R1}{R2} \right) + I_{REF} R1$$

- 2) Choose the value for R as follows:

- The maximum limit for R should be such that the cathode current, I_Z , is greater than the minimum operating current (130µA) at $V_{IN(MIN)}$.
- The minimum limit for R should be such that I_Z does not exceed 150mA under all load conditions, and the instantaneous turn-on value for I_Z does not exceed 200mA. Both of the following conditions must be met:

$$R_{min} \geq \frac{V_{IN(max)}}{200mA}$$

(to limit instantaneous turn-on I_Z)

$$R_{min} \geq \frac{V_{IN(max)} - V_{OUT}}{I_{OUT(min)} + 150mA}$$

(to limit I_Z under normal operating conditions)

Pin Configuration

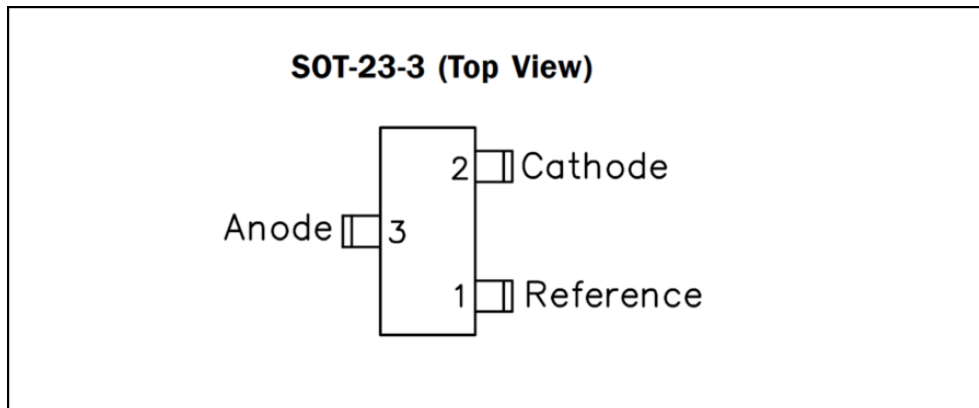

Marking Information

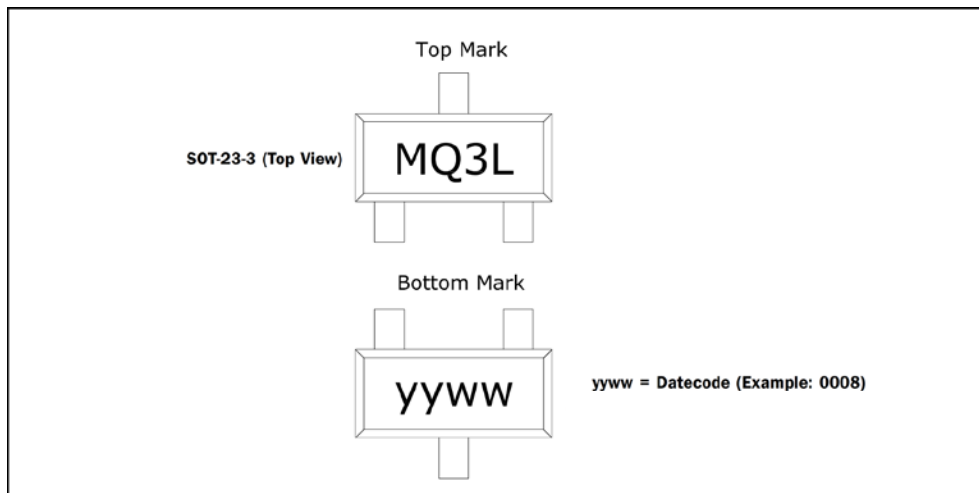

Ordering Information

Device	Package
SC431MSKQTRT ⁽¹⁾⁽²⁾	SOT-23-3

Notes:

(1): Only available in tape and reel packaging. A reel contains 3,000 devices. Consult factory for smaller quantities.

(2): This product is Pb-free, Halogen Free, RoHS / WEEE compliant.

Absolute Maximum Ratings

Parameter	Symbol	Value	Units
Cathode Voltage	V_Z	31	V
Continuous Cathode Current	I_Z	150	mA
Reference Input Current	I_{REF}	10	mA
Power Dissipation at $T_A = 25^\circ\text{C}$ SOT-23-3	P_D	0.37	W
Thermal Resistance SOT-23-3	θ_{JA}	336	$^\circ\text{C}/\text{W}$
Operating Ambient Temperature Range	T_A	-55 to +125	$^\circ\text{C}$
Operating Junction Temperature Range	T_J	-55 to +150	$^\circ\text{C}$
Storage Temperature Range	T_{STG}	-65 to +150	$^\circ\text{C}$
Lead Temperature (Soldering) 10 seconds	T_{LEAD}	300	$^\circ\text{C}$
ESD Rating (Human Body Model)	V_{ESD}	2	kV

Notes:

- (1): If multiple diodes conduct in the forward direction at any instant, the sum of the currents must not exceed this rating.
- (2): ESD Gun return path to Ground Reference Plane (GRP)
- (3): Any one diode to ambient.

Electrical Characteristics

Unless specified: $T_A = 25^\circ\text{C}$. Values in **bold** apply over full operating ambient temperature range.

Parameter	Symbol	Conditions	Min.	Typ.	Max.	Units
Reference Voltage	V_{REF}	$V_Z = V_{REF}, I_Z = 10\text{mA}^{(1)}$	2.482	2.495	2.507	V
V_{REF} Temp Deviation	V_{DEV}	$V_Z = V_{REF}, I_Z = 10\text{mA}^{(1)}$		8	25	mV
Ratio of Change in V_{REF} to Change in V_Z	$\frac{\Delta V_{REF}}{\Delta V_Z}$	$I_Z = 10\text{mA}, \Delta V_Z = 10\text{V to } V_{REF}$		-0.5	-2.7	mV/V
		$I_Z = 10\text{mA}, \Delta V_Z = 30\text{V to } 10\text{V}$		-1.0	-2.0	
Reference Input Current	I_{REF}	$R1 = 10\text{k}\Omega, R2 = \infty,$ $I_Z = 10\text{mA}^{(2)}$		0.5	4	μA
I_{REF} Temperature Deviation	$I_{REF(DEV)}$	$R1 = 10\text{k}\Omega, R2 = \infty,$ $I_Z = 10\text{mA}^{(2)}$		0.4	1.2	μA
Off-State Cathode Current	$I_{Z(OFF)}$	$V_{REF} = 0\text{V}, V_Z = 30\text{V}^{(3)}$		0.04	0.5	μA
Dynamic Output Impedance	r_Z	$f < 1\text{kHz}, V_Z = V_{REF}$ $I_Z = 130\mu\text{A to } 100\text{mA}^{(1)}$		0.25	0.5	Ω
Minimum Operating Current	$I_{Z(MIN)}$	$V_Z = V_{REF}^{(1)}$			130	μA

Notes:

- (1): See Test Circuit 1 on page 4.
- (2): See Test Circuit 2 on page 4.
- (3): See Test Circuit 3 on page 4.

Test Circuits

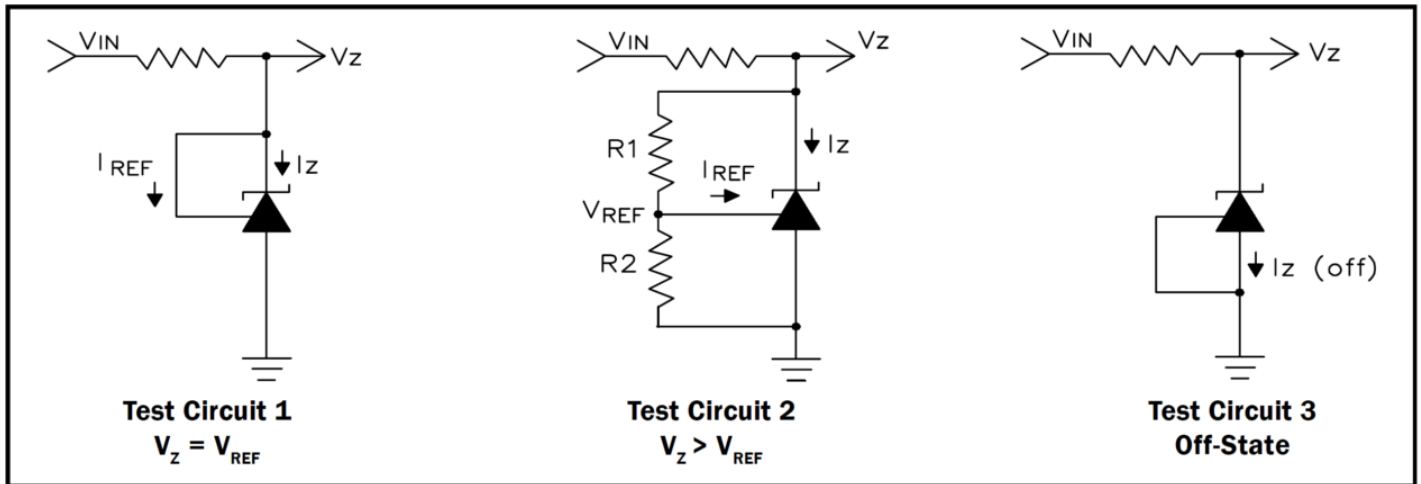

Recommended Operating Conditions

Parameter	Min.	Max.	Units
Cathode Voltage, V_z	V_{REF}	30	V
Cathode Current, I_z	0.130	150	mA

Block Diagram

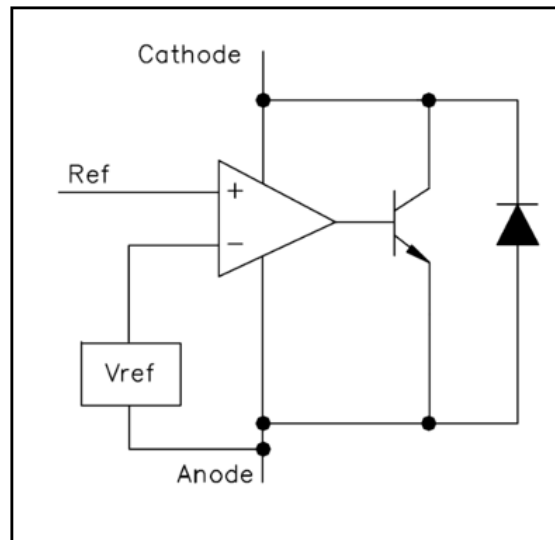

Typical Characteristics

Figure 1: Cathode Current vs Cathode Voltage

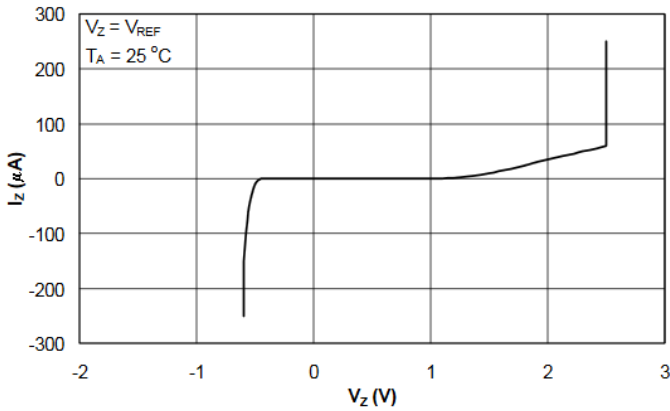

Figure 2: Cathode Current vs Cathode Voltage

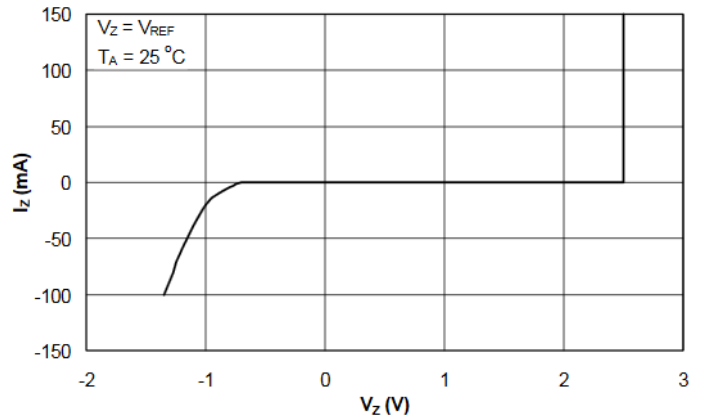

Figure 3: Reference Voltage vs. Junction Temperature

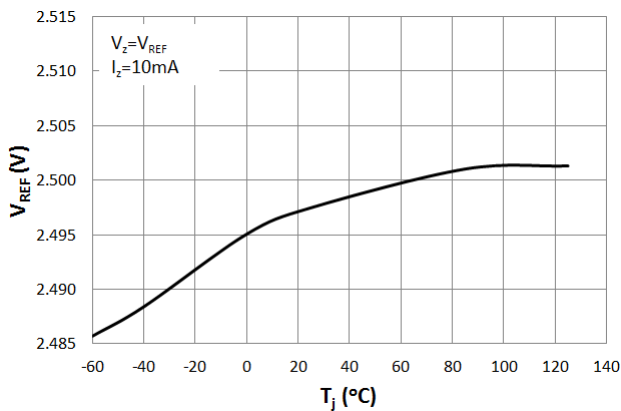

Figure 4: Ratio of Delta Reference Voltage to Delta Cathode Voltage vs. Junction Temperature

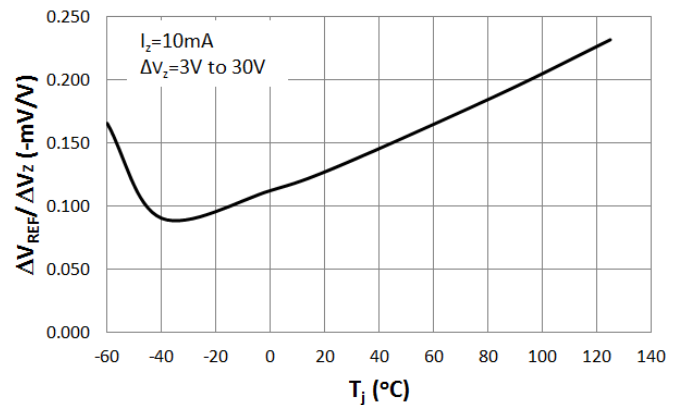

Figure 5: Reference Input Current vs. Junction Temperature

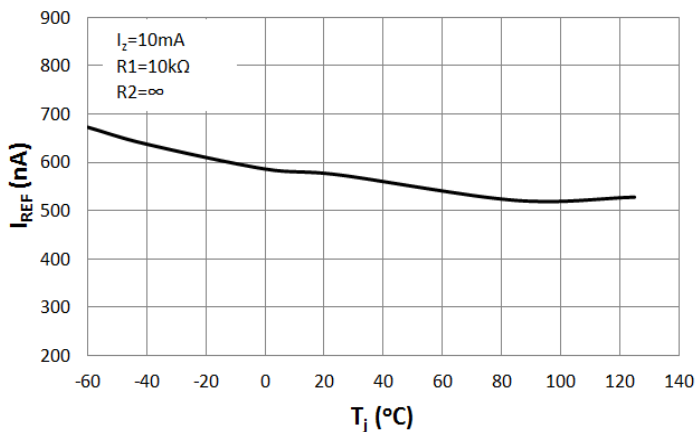
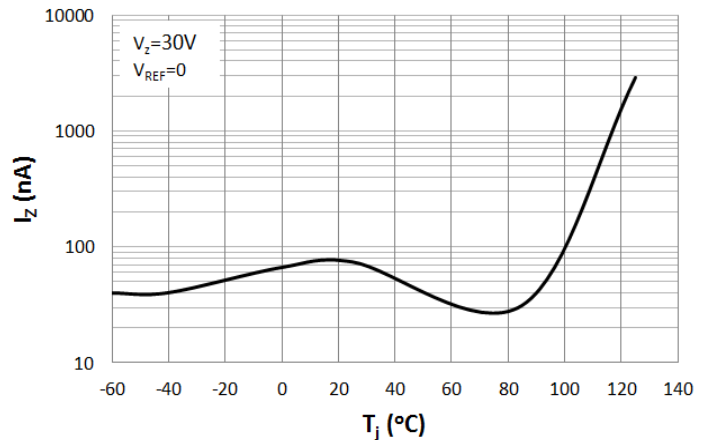

Figure 6: Off-State Cathode Current vs. Junction Temperature



Typical Characteristics (Cont.)

Figure 7: Small-Signal Gain and Phase Shift vs. Frequency

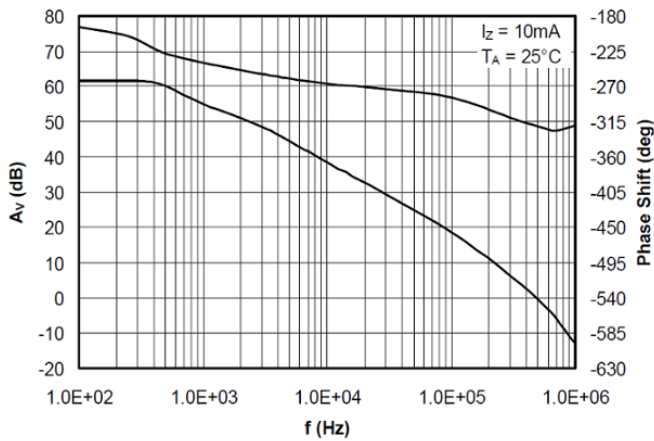

Figure 8: Test Circuit – Small-Signal Gain and Phase

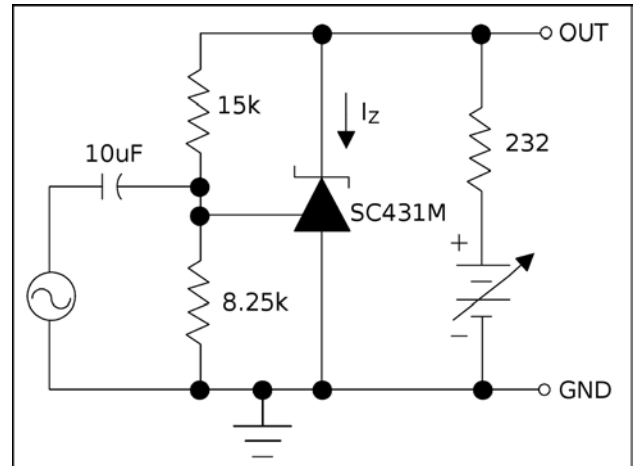

Figure 9: Stability Boundary Condition for Shunt Regulation vs. Cathode Current and Load Capacitance

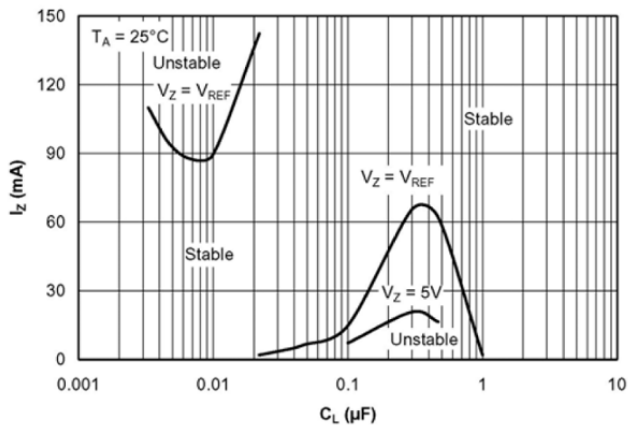

Figure 10: Test Circuit - Stability

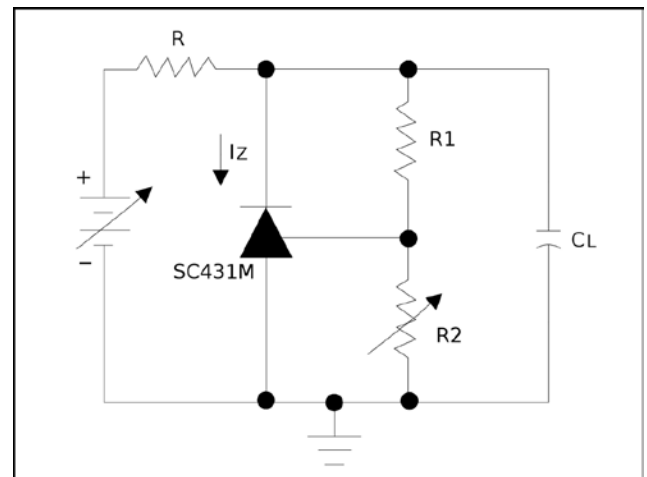
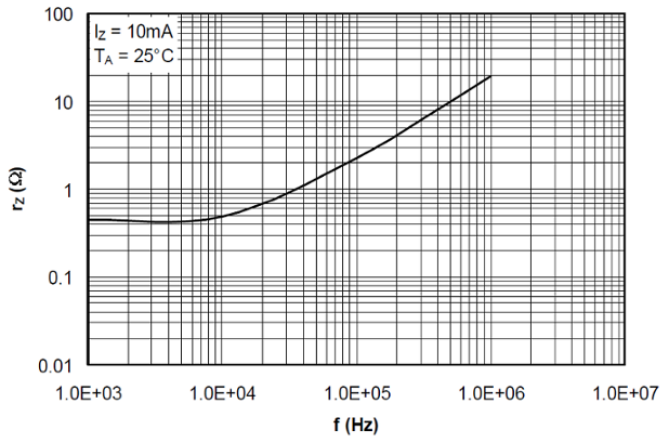
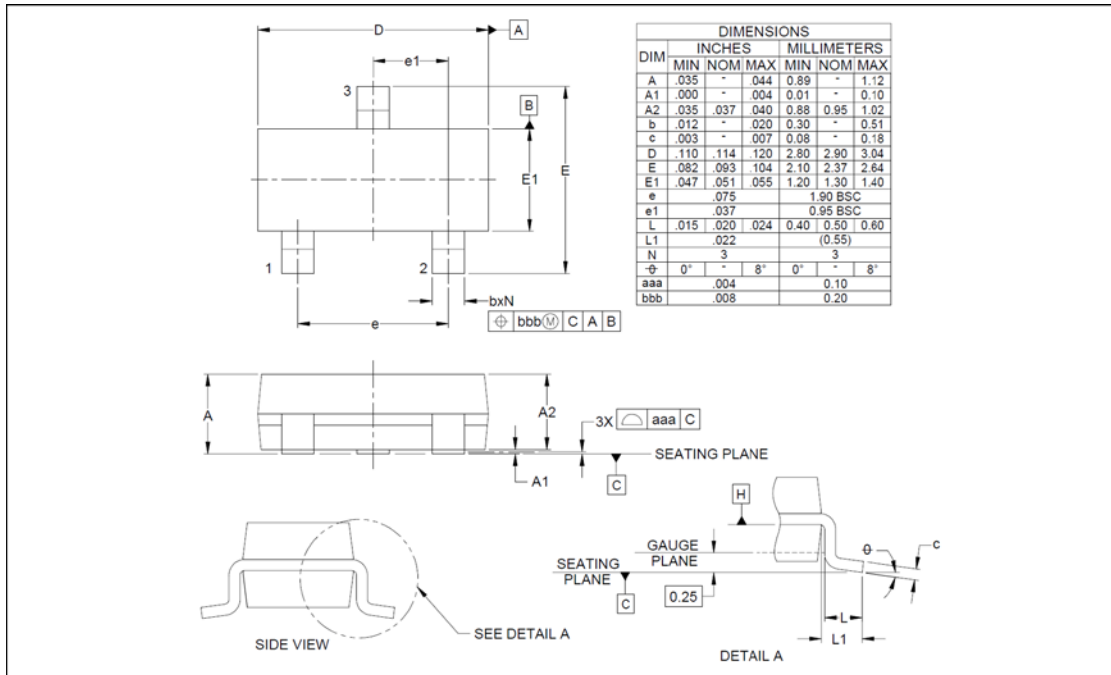

Figure 11: Reference Impedance vs. Frequency



Outline Drawing – SOT-23-3



Notes:

- (1) Controlling dimensions are in millimeters (angles in degrees).
- (2) Datums \boxed{A} and \boxed{B} to be determined at datum plane \boxed{H}
- (3) Dimensions "E1" and "D" do not include mold flash, protrusions or gate burrs.

Land Pattern – SOT-23-3

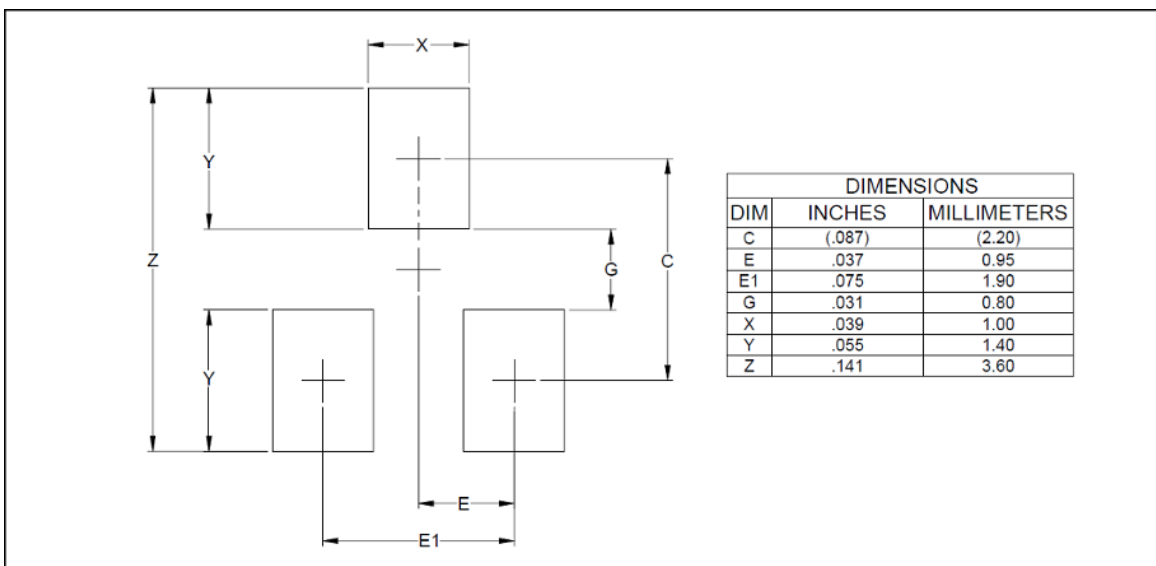

Notes:

- (1) This land pattern is for reference purposes only. Consult your manufacturing group to ensure that your company's manufacturing guidelines are met.
- (2) Reference IPC-SM-782A



Important Notice

Information relating to this product and the application or design described herein is believed to be reliable, however such information is provided as a guide only and Semtech assumes no liability for any errors in this document, or for the application or design described herein. Semtech reserves the right to make changes to the product or this document at any time without notice. Buyers should obtain the latest relevant information before placing orders and should verify that such information is current and complete. Semtech warrants performance of its products to the specifications applicable at the time of sale, and all sales are made in accordance with Semtech's standard terms and conditions of sale.

SEMTECH PRODUCTS ARE NOT DESIGNED, INTENDED, AUTHORIZED OR WARRANTED TO BE SUITABLE FOR USE IN LIFE-SUPPORT APPLICATIONS, DEVICES OR SYSTEMS, OR IN NUCLEAR APPLICATIONS IN WHICH THE FAILURE COULD BE REASONABLY EXPECTED TO RESULT IN PERSONAL INJURY, LOSS OF LIFE OR SEVERE PROPERTY OR ENVIRONMENTAL DAMAGE. INCLUSION OF SEMTECH PRODUCTS IN SUCH APPLICATIONS IS UNDERSTOOD TO BE UNDERTAKEN SOLELY AT THE CUSTOMER'S OWN RISK. Should a customer purchase or use Semtech products for any such unauthorized application, the customer shall indemnify and hold Semtech and its officers, employees, subsidiaries, affiliates, and distributors harmless against all claims, costs damages and attorney fees which could arise.

The Semtech name and logo are registered trademarks of the Semtech Corporation. All other trademarks and trade names mentioned may be marks and names of Semtech or their respective companies. Semtech reserves the right to make changes to, or discontinue any products described in this document without further notice. Semtech makes no warranty, representation or guarantee, express or implied, regarding the suitability of its products for any particular purpose. All rights reserved.

© Semtech 2016

Contact Information

Semtech Corporation
High-Reliability Products
200 Flynn Road, Camarillo, CA 93012
Phone: (805) 498-2111, Fax: (805) 498-3804

For general inquiries, sales and technical supports:
www.semtech.com/contact

X-ON Electronics

Largest Supplier of Electrical and Electronic Components

Click to view similar products for [Voltage References](#) category:

Click to view products by [Semtech](#) manufacturer:

Other Similar products are found below :

[REF01J/883](#) [5962-8686103XC](#) [NCV431BVDMR2G](#) [LT6654AMPS6-2.048#TRMPBF](#) [SCV431AIDMR2G](#) [SC431ILPRAG](#) [AP432AQG-7](#)
[TL431-A](#) [MCP1502T-18E/CHY](#) [MCP1502T-40E/CHY](#) [TL431ACZ](#) [KA431SLMF2TF](#) [KA431SMF2TF](#) [KA431SMFTF](#) [LM4041C12ILPR](#)
[LM4120AIM5-2.5/NOP](#) [LM431SCCMFX](#) [REF3012AIDBZR](#) [LM285BXM-1.2/NOPB](#) [LM385BM-2.5/NOPB](#) [LM4040AIM3-10.0](#)
[LM4040BIM3-4.1](#) [LM4040CIM3-10.0](#) [LM4040CIM3X-2.0/NOPB](#) [LM4041QDIM3-ADJ/NO](#) [LM4050QAEM3X4.1/NOPB](#) [LM4051BIM3-](#)
[ADJ/NOPB](#) [LM4051CIM3X-1.2/NOPB](#) [LM4128CMF-1.8/NOPB](#) [LM4132DMF-1.8/NOPB](#) [LM4132EMF-1.8/NOPB](#) [LM4132EMF-](#)
[2.0/NOPB](#) [LM4140CCMX-1.2/NOPB](#) [LM385BD-2.5R2G](#) [LM385M-2.5/NOPB](#) [LM4030AMF-4.096/NOPB](#) [LM4040D30ILPR](#)
[LM4051CIM3X-ADJ/NOPB](#) [AP432YG-13](#) [AS431ANTR-G1](#) [AS431BZTR-E1](#) [AN431AN-ATRG1](#) [AP431IBNTR-G1](#) [AS431ARTR-G1](#)
[AS431BNTR-G1](#) [TL431AIZ](#) [AZ431AN-ATRG1](#) [AZ431AZ-ATRE1](#) [AZ431LANTR-G1](#) [TLV431AH6TA](#)