

POWER MANAGEMENT

Description

The SC4503 is a 1.3MHz current-mode step-up switching regulator with an integrated 1.4A power transistor. Its high switching frequency allows the use of tiny surface-mount external passive components. The SC4503 features a combined shutdown and soft-start pin. The optional soft-start function eliminates high input current and output overshoot during start-up. The internal compensation network accommodates a wide range of voltage conversion ratios. The internal switch is rated at 34V making the device suitable for high voltage applications such as Boost and SEPIC.

The SC4503 is available in low-profile 5-Lead TSOT-23 and 8-Lead 2X2mm MLPD-W packages. The SC4503's low shutdown current ($< 1\mu\text{A}$), high frequency operation and small size make it suitable for portable applications.

Features

- ◆ Low Saturation Voltage Switch: 260mV at 1.4A
- ◆ 1.3MHz Constant Switching Frequency
- ◆ Peak Current-mode Control
- ◆ Internal Compensation
- ◆ Programmable Soft-Start
- ◆ Input Voltage Range From 2.5V to 20V
- ◆ Output Voltage up to 27V
- ◆ Uses Small Inductors and Ceramic Capacitors
- ◆ Low Shutdown Current ($< 1\mu\text{A}$)
- ◆ Low Profile 5-Lead TSOT-23 and 8-Lead 2X2mm MLPD-W packages
- ◆ Fully WEEE and RohS compliant

Applications

- ◆ Local DC-DC Converters
- ◆ TFT Bias Supplies
- ◆ XDSL Power Supplies
- ◆ Medical Equipment
- ◆ Digital Cameras
- ◆ Portable Devices
- ◆ White LED Drivers

Typical Application Circuit

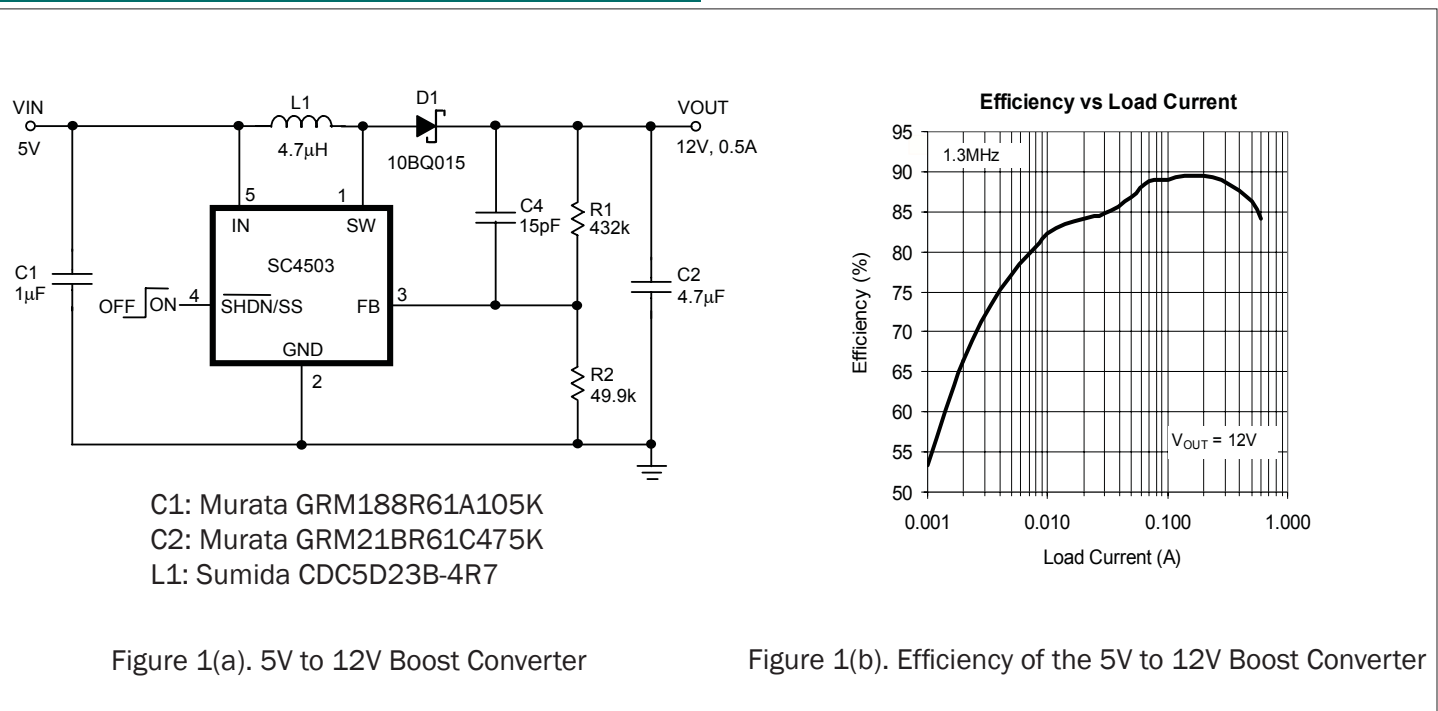

POWER MANAGEMENT
Absolute Maximum Ratings

Exceeding the specifications below may result in permanent damage to the device or device malfunction. Operation outside of the parameters specified in the Electrical Characteristics section is not recommended.

Parameter	Symbol	Maximum	Units
Supply Voltage	V_{IN}	-0.3 to 20	V
SW Voltage	V_{SW}	-0.3 to 34	
FB Voltages	V_{FB}	-0.3 to $V_{IN} + 0.3$	
SHDN/SS Voltage	V_{SHDN}	-0.3 to $V_{IN} + 1$	
Thermal Resistance Junction to Ambient (TSOT - 23)	θ_{JA}	191*	°C/W
Thermal Resistance Junction to Ambient (2X2mm MLPD-W)	θ_{JA}	78*	°C/W
Maximum Junction Temperature	T_J	150	°C
Storage Temperature Range	T_{STG}	-65 to +150	
Lead Temperature (Soldering)10 sec (TSOT - 23)	T_{LEAD}	260	
Peak IR Reflow Temperature (2X2mm MLPD-W)	T_{IR}	260	
ESD Rating (Human Body Model)	ESD	2000	

*Calculated from package in still air, mounted to 3" x 4.5", 4 layer FR4 PCB with thermal via under the exposed pad as per JESD51 standards.

Electrical Characteristics

Unless specified: $V_{IN} = V_{SHDN/SS} = 3V$, $-40^{\circ}C < T_A = T_J < 85^{\circ}C$

Parameter	Conditions	Min	Typ	Max	Units
Under-Voltage Lockout Threshold			2.2	2.5	V
Maximum Operating Voltage				20	
Feedback Voltage		1.225	1.250	1.275	
Feedback Line Voltage Regulation	$2.5V < V_{IN} < 20V$		0.02		%/V
FB Pin Bias Current			-25	-50	nA
Switching Frequency		1.15	1.30	1.55	MHz
Minimum Duty Cycle				0	%
Maximum Duty Cycle		86	90		
Switch Current Limit		1.4	1.9	2.5	A
Switch Saturation Voltage	$I_{SW} = 1.4A$		260	430	mV
Switch Leakage Current	$V_{SW} = 5V$		0.01	1	μA
V_{IN} Quiescent Supply Current	$V_{SHDN/SS} = 2V$, $V_{FB} = 1.5V$ (not switching)		0.8	1.1	mA
V_{IN} Supply Current in Shutdown	$V_{SHDN/SS} = 0$		0.01	1	μA

POWER MANAGEMENT
Electrical Characteristics (Cont.)

 Unless specified: $V_{IN} = V_{\overline{SHDN/SS}} = 3V$, $-40^{\circ}C < T_A = T_J < 85^{\circ}C$

Parameter	Conditions	Min	Typ	Max	Units
$\overline{SHDN/SS}$ Switching Threshold	$V_{FB} = 0V$		1.4		V
Shutdown Input High Voltage		2			V
Shutdown Input Low Voltage				0.4	
$\overline{SHDN/SS}$ Pin Bias Current	$V_{\overline{SHDN/SS}} = 2V$		22	50	μA
	$V_{\overline{SHDN/SS}} = 1.8V$		20	45	
	$V_{\overline{SHDN/SS}} = 0V$			0.1	
Thermal Shutdown Temperature			155		$^{\circ}C$
Thermal Shutdown Hysteresis			10		

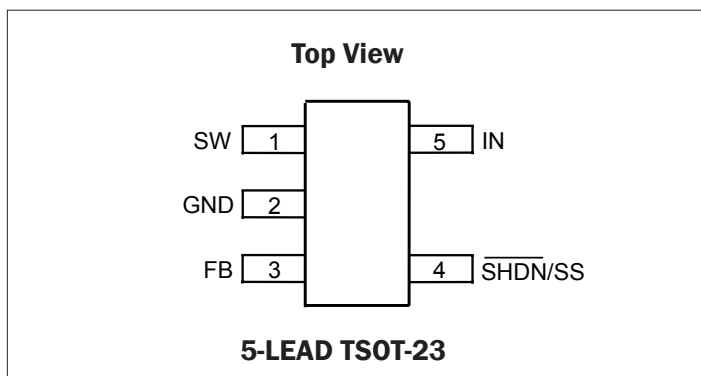
Pin Configuration - TSOT - 23

Ordering Information

Device ^(1,2)	Top Mark	Package
SC4503TSKTRT	BH00	TSOT-23
SC4503EVB	Evaluation Board	

Notes:

(1) Available in tape and reel only. A reel contains 3,000 devices.

(2) Available in lead-free package only. Device is WEEE and RoHS compliant.

Pin Descriptions - TSOT -23

Pin	Pin Name	Pin Functions
1	SW	Collector of the internal power transistor. Connect to the boost inductor and the freewheeling diode. The maximum switching voltage spike at this pin should be limited to 34V.
2	GND	Ground. Tie to ground plane.
3	FB	The inverting input of the error amplifier. Tie to an external resistive divider to set the output voltage.
4	$\overline{SHDN/SS}$	Shutdown and Soft-start Pin. Pulling this pin below 0.4V shuts down the converter. Applying more than 2V at this pin enables the SC4503. An external resistor and an external capacitor connected to this pin soft-start the switching regulator. The SC4503 will try to pull the $\overline{SHDN/SS}$ pin below its 1.4V switching threshold regardless of the external circuit attached to the pin if V_{IN} is below the under-voltage lockout threshold. Tie this pin through an optional resistor to IN or to the output of a controlling logic gate if soft-start is not used. See Applications Information for more details.
5	IN	Power Supply Pin. Bypassed with capacitor close to the pin.

POWER MANAGEMENT

Pin Configuration - 2X2mm MLPD-W

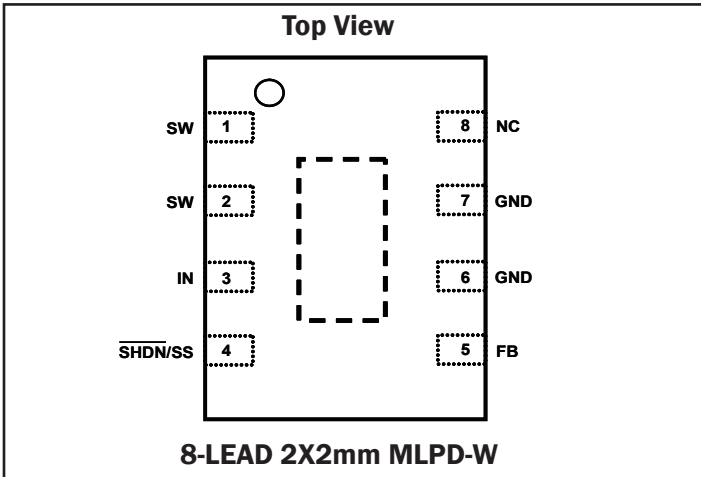

Ordering Information

Device ^(1,2)	Top Mark	Package
SC4503WLTRT	E00	2X2mm MLPD-W
SC4503_MLPD EVB	Evaluation Board	

Notes:

- (1) Available in tape and reel only. A reel contains 3,000 devices.
- (2) Available in lead-free package only. Device is WEEE and RoHS compliant.

Pin Descriptions - 2X2mm MLPD-W

Pin	Pin Name	Pin Functions
1,2	SW	Collector of the internal power transistor. Connect to the boost inductor and the free-wheeling diode. The maximum switching voltage spike at this pin should be limited to 34V.
3	IN	Power Supply Pin. Bypassed with capacitor close to the pin.
4	SHDN/SS	Shutdown and Soft-start Pin. Pulling this pin below 0.4 shuts down the converter. Applying more than 2V at this pin enables the SC4503. An external resistor and an external capacitor connected to this pin soft-start the switching regulator. The SC4503 will try to pull the SHDN/SS pin below its 1.4V switching threshold regardless of the external circuit attached to the pin if VIN is below the under-voltage lockout threshold. Tie this pin through an optional resistor to IN or to the output of a controlling logic gate if soft-start is not used. See Applications Information for more details.
5	FB	The inverting input of the error amplifier. Tie to an external resistive divider to set the output voltage.
6,7	GND	Ground. Tie to ground plane.
8	N.C.	No Connection.
EDP		Solder to the ground plane of the PCB.

POWER MANAGEMENT

Block Diagram

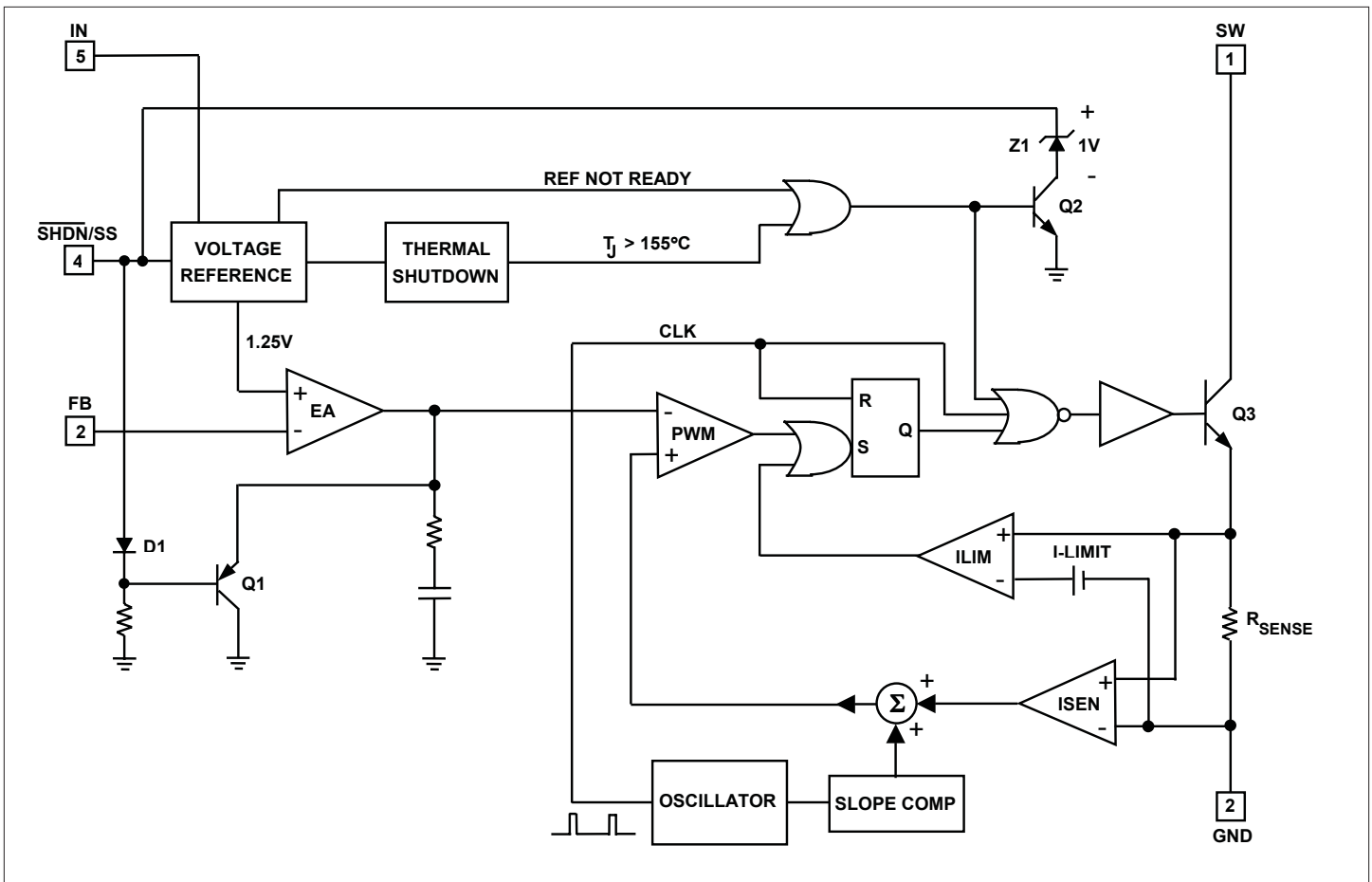
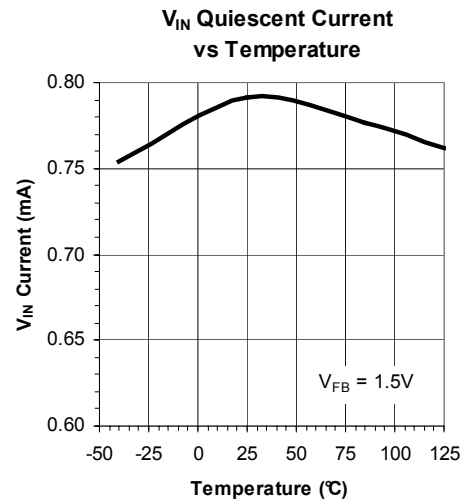
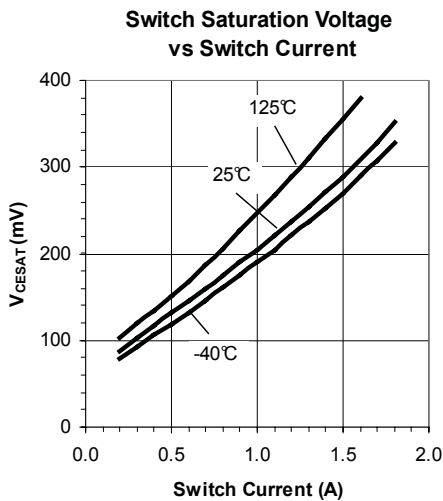
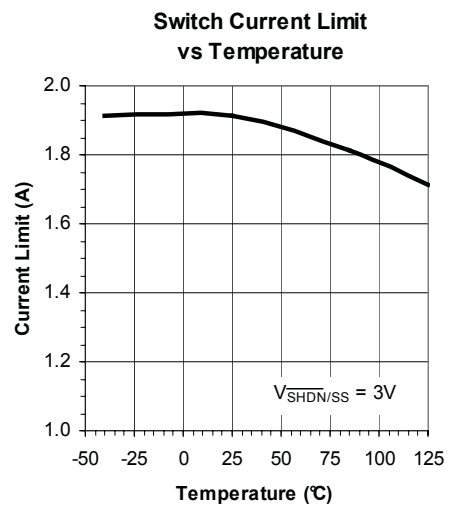
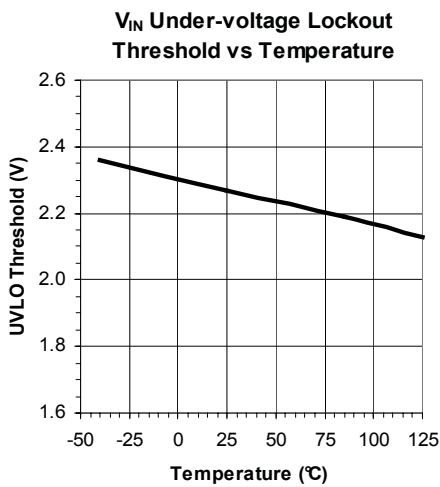
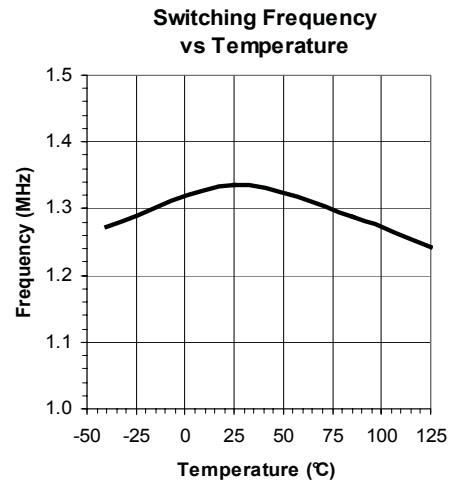
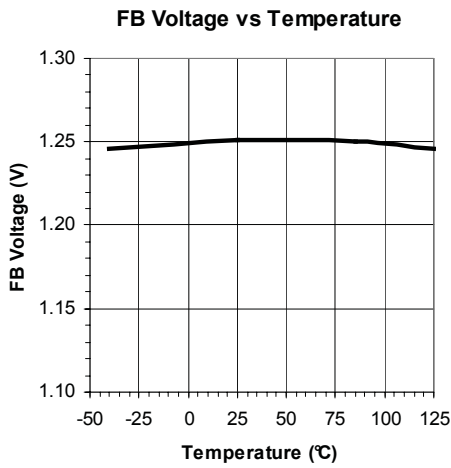
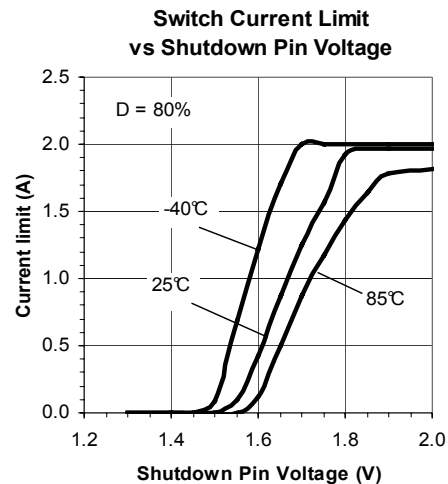
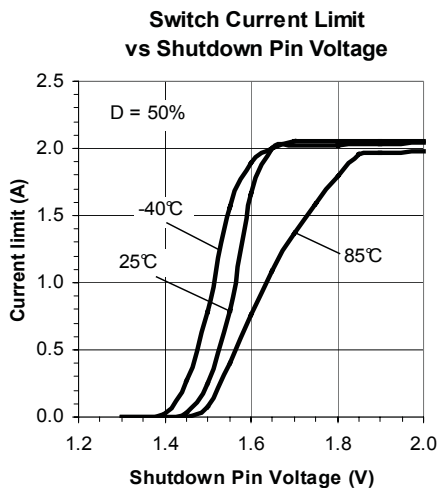
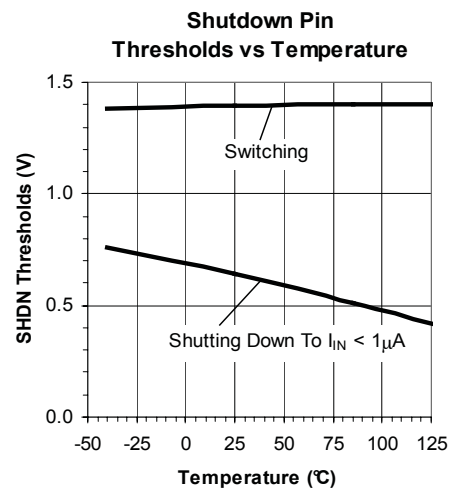
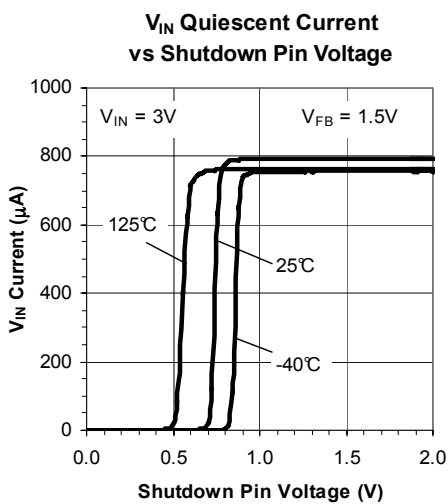
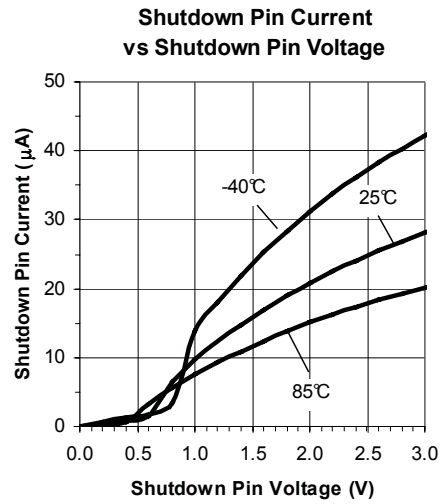
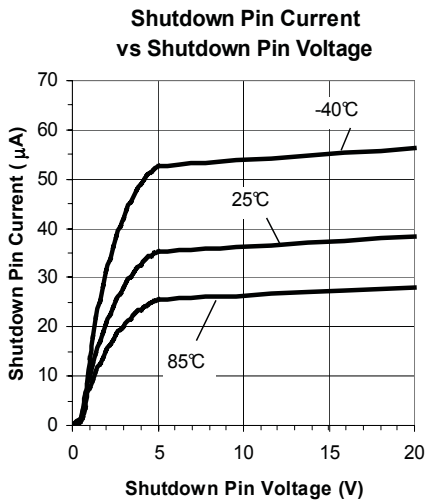

Figure 2. SC4503 Block Diagram





Operation

The SC4503 is a 1.3MHz peak current-mode step-up switching regulator with an integrated 1.4A (minimum) power transistor. Referring to the block diagram, Figure 2, the clock CLK resets the latch and blanks the power transistor Q₃ conduction. Q₃ is switched on at the trailing edge of the clock.

Switch current is sensed with an integrated sense resistor. The sensed current is summed with the slope-compensating ramp and fed into the modulating ramp input of the PWM comparator. The latch is set and Q₃ conduction is terminated when the modulating ramp intersects the error amplifier (EA) output. If the switch current exceeds 1.9A (the typical current-limit), then the current-limit comparator ILIM will set the latch and turn off Q₃. Due to separate pulse-width modulating and current limiting paths, cycle-by-cycle current limiting is not affected by slope compensation.

The current-mode switching regulator is a dual-loop feedback control system. In the inner current loop the EA output controls the peak inductor current. In the outer loop, the error amplifier regulates the output voltage. The double reactive poles of the output LC filter are reduced to a single real pole by the inner current loop, allowing the internal loop compensation network to accommodate a wide range of input and output voltages.

Applying 0.9V at the $\overline{\text{SHDN}}/\text{SS}$ pin enables the voltage reference. The signal “REF NOT READY” does not go low until V_{IN} exceeds its under-voltage lockout threshold (typically 2.2V). Assume that an external resistor is placed between the IN and the $\overline{\text{SHDN}}/\text{SS}$ pins during startup. The voltage reference is enabled when the $\overline{\text{SHDN}}/\text{SS}$ voltage rises to 0.9V. Before V_{IN} reaches 2.2V, “REF NOT READY” is high. Q₂ turns on and the Zener diode Z₁ loosely regulates the $\overline{\text{SHDN}}/\text{SS}$ voltage to 1V (above the reference enabling voltage). The optional external resistor limits the current drawn during under-voltage lockout.

When V_{IN} exceeds 2.2V, “REF NOT READY” goes low. Q₂ turns off, releasing $\overline{\text{SHDN}}/\text{SS}$. If an external capacitor is connected from the $\overline{\text{SHDN}}/\text{SS}$ pin to the ground, the $\overline{\text{SHDN}}/\text{SS}$ voltage will ramp up slowly. The error amplifier output, which is

clamped by D1 and Q1, follows the voltage at the $\overline{\text{SHDN}}/\text{SS}$ pin. The input inductor current, which is in turn controlled by the error amplifier output, also ramps up gradually. Soft-starting the SC4503 in this manner eliminates high input current and output overshoot. Under fault condition (V_{IN} < 2.2V or over-temperature), the soft-start capacitor is discharged to 1V. When the fault condition disappears, the converter again undergoes soft-start.

Setting the Output Voltage

An external resistive divider R₁ and R₂ with its center tap tied to the FB pin (Figure 3) sets the output voltage.

$$R_1 = R_2 \left(\frac{V_{\text{OUT}}}{1.25\text{V}} - 1 \right) \tag{1}$$

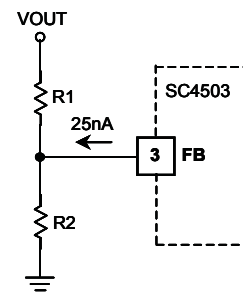

Figure 3. R₁- R₂ Divider Sets the Output Voltage

The input bias current of the error amplifier will introduce an error of:

$$\frac{\Delta V_{\text{OUT}}}{V_{\text{OUT}}} = - \frac{25\text{nA} \cdot (R_1 || R_2) \cdot 100}{1.25\text{V}} \% \tag{2}$$

The percentage error of a V_{OUT} = 5V converter with R₁ = 100kΩ and R₂ = 301kΩ is

$$\frac{\Delta V_{\text{OUT}}}{V_{\text{OUT}}} = - \frac{25\text{nA} \cdot (100\text{k} || 301\text{k}) \cdot 100}{1.25\text{V}} = -0.15\%$$

This error is much less than the ratio tolerance resulting from the use of 1% resistors in the divider string.

POWER MANAGEMENT

Applications Information (Cont.)

Duty Cycle

The duty cycle D of a boost converter in continuous-conduction mode (CCM) is:

$$D = \frac{1 - \frac{V_{IN}}{V_{OUT} + V_D}}{1 - \frac{V_{CESAT}}{V_{OUT} + V_D}} \quad (3)$$

where V_{CESAT} is the switch saturation voltage and V_D is voltage drop across the rectifying diode.

Maximum Output Current

In a boost switching regulator the inductor is connected to the input. The inductor DC current is the input current. When the power switch is turned on, the inductor current flows into the switch. When the power switch is off, the inductor current flows through the rectifying diode to the output. The output current is the average diode current. The diode current waveform is trapezoidal with pulse width $(1 - D)T$ (see Figure 4). The output current available from

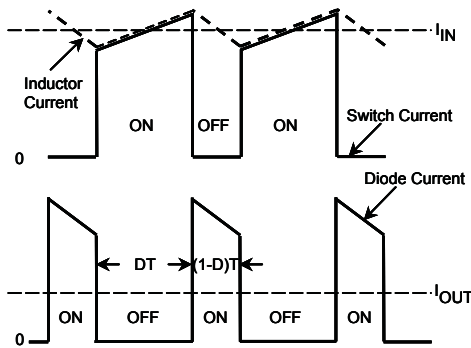

Figure 4. Current Waveforms in a Boost Converter

a boost converter therefore depends on the converter operating duty cycle. The power switch current in the SC4503 is internally limited to at least 1.4A. This is also the maximum peak inductor or the peak input current. By estimating the conduction losses in both the switch and the diode, an expression of the maximum available output current of a boost converter can be derived:

$$I_{OUTMAX} = \frac{I_{LIM} V_{IN}}{V_{OUT}} \left[1 - \frac{D}{65} - \frac{V_D - D(V_D - V_{CESAT})}{V_{IN}} \right] \quad (4)$$

where I_{LIM} is the switch current limit.

It is worth noting that I_{OUTMAX} is directly proportional to the ratio $\frac{V_{IN}}{V_{OUT}}$ and that switching losses are neglected in its

derivation. Equation (4) therefore over-estimates the maximum output current, however it is a useful first-order approximation.

Using $V_{CESAT} = 0.3V$, $V_D = 0.5V$ and $I_{LIM} = 1.4A$ in (3) and (4), the maximum output current for three V_{IN} and V_{OUT} combinations are tabulated (Table 1).

V_{IN} (V)	V_{OUT} (V)	D	I_{OUT} (A)
3.3	12	0.754	0.34
3.3	5	0.423	0.80
5	12	0.615	0.53

Table 1. Calculated Maximum Output Currents

Maximum Duty-Cycle Limitation

The power transistor in the SC4503 is turned off every switching period for 80ns. This minimum off time limits the maximum duty cycle of the regulator. A boost converter with high $\frac{V_{OUT}}{V_{IN}}$ ratio requires long switch on time and high duty cycle. If the required duty cycle is higher than the attainable maximum, then the converter will operate in dropout. (Dropout is a condition in which the regulator cannot attain its set output voltage below current limit.)

Note: dropout can occur when operating at low input voltages (<3V) and with off times approaching 100ns. Shorten the PCB trace between the power source and the device input pin, as line drop may be a significant percentage of the input voltage. A regulator in dropout may appear as if it is in current limit. The cycle-by-cycle current limit of the SC4503 is duty-cycle and input voltage invariant and should be at least 1.4A. If the converter output is below its set value and switch current limit is not reached (1.4A), then the converter is likely in dropout.

Example: Determine the highest attainable output voltage when boosting from a single Li-ion cell.

Equation (3) can be re-arranged as:

POWER MANAGEMENT
Applications Information (Cont.)

$$V_{OUT} = \frac{V_{IN} - DV_{CESAT}}{1 - D} - V_D \quad (5)$$

Assuming that the voltage of a nearly discharged Li-ion cell is 2.6V. Using $V_D = 0.5V$, $V_{CESAT} = 0.3V$ and $D = 0.86$ in (5),

$$V_{OUT} < \frac{2.6 - 0.86 \cdot 0.3}{1 - 0.86} - 0.5 = 16V$$

Transient headroom requirement further reduces the maximum achievable output voltage to below 16V.

Minimum Controllable On-Time

The operating duty cycle of a boost converter decreases as V_{IN} approaches V_{OUT} . Sensed switch current ramp modulates the pulse width in a current-mode switching regulator. This current ramp is absent unless the switch is turned on. The intersection of this ramp with the error amplifier output determines the switch on-time. The propagation delay time required to immediately turn off the switch after it is turned on is the minimum controllable on time. Measured minimum on time of the SC4503 is load-dependent and ranges from 180ns to 220ns at room temperature. The switch in the SC4503 is either not turned on, or, for at least this minimum. If the regulator requires a switch on-time less than this controllable minimum, then it will either skip cycles or start to jitter.

Inductor Selection

The inductor ripple current ΔI_L of a boost converter in continuous-conduction mode is

$$\Delta I_L = \frac{D(V_{IN} - V_{CESAT})}{fL} \quad (6)$$

where f is the switching frequency and L is the inductance.

Substituting (3) into (6) and neglecting V_{CESAT}

$$\Delta I_L = \frac{V_{IN}}{fL} \left(1 - \frac{V_{IN}}{V_{OUT} + V_D} \right) \quad (7)$$

In current-mode control, the slope of the modulating (sensed switch current) ramp should be steep enough to

lessen jittery tendency but not so steep that large flux swing decreases efficiency. For continuous-conduction mode operation, inductor ripple current ΔI_L between 0.35A and 0.6A is a good compromise. Setting $\Delta I_L = 0.43A$, $V_D = 0.5V$ and $f = 1.3MHz$ in (7),

$$L = \frac{V_{IN}}{f\Delta I_L} \left(1 - \frac{V_{IN}}{V_{OUT} + V_D} \right) = \frac{V_{IN}}{0.56} \left(1 - \frac{V_{IN}}{V_{OUT} + 0.5} \right) \quad (8)$$

where L is in μH .

Equation (7) shows that for a given V_{OUT} , ΔI_L is the highest when $V_{IN} = \frac{(V_{OUT} + V_D)}{2}$. If V_{IN} varies over a wide range, then choose L based on the nominal input voltage.

The saturation current of the inductor should be 20-30% higher than the peak current limit (1.9 A). Low-cost powder iron cores are not suitable for high-frequency switching power supplies due to their high core losses. Inductors with ferrite cores should be used.

Discontinuous-Conduction Mode

The output-to-input voltage conversion ratio $M = \frac{V_{OUT}}{V_{IN}}$ in continuous-conduction mode is limited by the maximum duty cycle D_{MAX} :

$$M < \frac{1}{1 - D_{MAX}} = \frac{1}{1 - 0.86} = 7.1$$

Higher voltage conversion ratios can be achieved by operating the boost converter in full-time discontinuous-conduction mode (DCM). Define $R = \frac{V_{OUT}}{I_{OUT}}$ as the equivalent output load resistance. The following inequalities must be satisfied for DCM operation:

$$\frac{Lf}{R} < \frac{M - 1}{2M^3} \quad (9)$$

and,

$$I_{OUT} = \frac{V_{OUT}}{R} < \frac{0.7A}{M} \quad (10)$$

POWER MANAGEMENT
Applications Information (Cont.)

Switch on duty ratio in DCM is given by,

$$D = \sqrt{\frac{2Lf}{R} M(M-1)} \quad (11)$$

Higher input current ripples and lower output current are the drawbacks of DCM operation.

Input Capacitor

The input current in a boost converter is the inductor current, which is continuous with low RMS current ripples. A 2.2-4.7 μ F ceramic input capacitor is adequate for most applications.

Output Capacitor

Both ceramic and low ESR tantalum capacitors can be used as output filtering capacitors. Multi-layer ceramic capacitors, due to their extremely low ESR (<5m Ω), are the best choice. Use ceramic capacitors with stable temperature and voltage characteristics. One may be tempted to use Z5U and Y5V ceramic capacitors for output filtering because of their high capacitance density and small sizes. However these types of capacitors have high temperature and high voltage coefficients. For example, the capacitance of a Z5U capacitor can drop below 60% of its room temperature value at -25 $^{\circ}$ C and 90 $^{\circ}$ C. X5R ceramic capacitors, which have stable temperature and voltage coefficients, are the preferred type.

The diode current waveform in Figure 4 is discontinuous with high ripple-content. Unlike a buck converter in which the inductor ripple current ΔI_L determines the output ripple voltage. The output ripple voltage of a boost regulator is much higher and is determined by the absolute inductor current. Decreasing the inductor ripple current does not reduce the output ripple voltage appreciably. The current flowing in the output filter capacitor is the difference between the diode current and the output current. This capacitor current has a RMS value of:

$$I_{OUT} \sqrt{\frac{V_{OUT}}{V_{IN}} - 1} \quad (12)$$

If a tantalum capacitor is used, then its ripple current rating in addition to its ESR will need to be considered.

When the switch is turned on, the output capacitor supplies the load current I_{OUT} (Figure 4). The output ripple voltage due to charging and discharging of the output capacitor is therefore:

$$\Delta V_{OUT} = \frac{I_{OUT}DT}{C_{OUT}} \quad (13)$$

For most applications, a 10-22 μ F ceramic capacitor is sufficient for output filtering. It is worth noting that the output ripple voltage due to discharging of a 10 μ F ceramic capacitor (13) is higher than that due to its ESR.

Rectifying Diode

For high efficiency, Schottky barrier diodes should be used as rectifying diodes for the SC4503. These diodes should have an average forward current rating at least equal to the output current and a reverse blocking voltage of at least a few volts higher than the output voltage. For switching regulators operating at low duty cycles (i.e. low output voltage to input voltage conversion ratios), it is beneficial to use rectifying diodes with somewhat higher average current ratings (thus lower forward voltages). This is because the diode conduction interval is much longer than that of the transistor. Converter efficiency will be improved if the voltage drop across the diode is lower.

The rectifying diodes should be placed close to the SW pin of the SC4503 to minimize ringing due to trace inductance. Surface-mount equivalents of 1N5817 and 1N5818, MBRM120, MBR0520L, ZHCS400, 10BQ015 and equivalent are suitable.

Shutdown and Soft-Start

The shutdown ($\overline{\text{SHDN/SS}}$) pin is a dual function pin. When driven from a logic gate with $V_{OH} > 2V$, the $\overline{\text{SHDN/SS}}$ pin functions as an on/off input to the SC4503. When the shutdown pin is below 2V, it clamps the error amplifier output to $V_{\overline{\text{SHDN/SS}}}$ and reduces the switch current limit. Connecting R_{SS} and C_{SS} to the $\overline{\text{SHDN/SS}}$ pin (Figure 5) slows the voltage rise at the pin during start-up. This forces the peak inductor current (hence the input current) to follow a slow ramp, thus achieving soft-start.

POWER MANAGEMENT

Applications Information (Cont.)

The minimum $\overline{\text{SHDN/SS}}$ voltage for switching is 1.4V. The graph “Switch Current Limit vs. Shutdown Pin Voltage” in the “Typical Characteristics” shows that the $\overline{\text{SHDN/SS}}$ pin voltage needs to be at least 2V for the SC4503 to deliver its rated power. The effect of the $\overline{\text{SHDN/SS}}$ voltage on the SC4503 is **analog** between 1.4V and 2V. Within this range the switch current limit is determined not by I_{LIM} but instead by the PWM signal path (see Figure 2). Moreover it varies with duty cycle and the shutdown pin voltage.

Pulling the $\overline{\text{SHDN/SS}}$ pin below 0.4V shuts down the SC4503, drawing less than $1\mu\text{A}$ from the input power supply. For voltages above 2V and below 0.4V, the $\overline{\text{SHDN/SS}}$ pin can be regarded as a digital on/off input. Figure 5 shows several ways of interfacing the control logic to the shutdown pin. In Figure 5(a) soft-start is not used and the logic gate drives the shutdown pin through a small ($\approx 1\text{k}\Omega$) optional resistor R_{SS} . R_{SS} limits the current drawn by the SC4503 internal

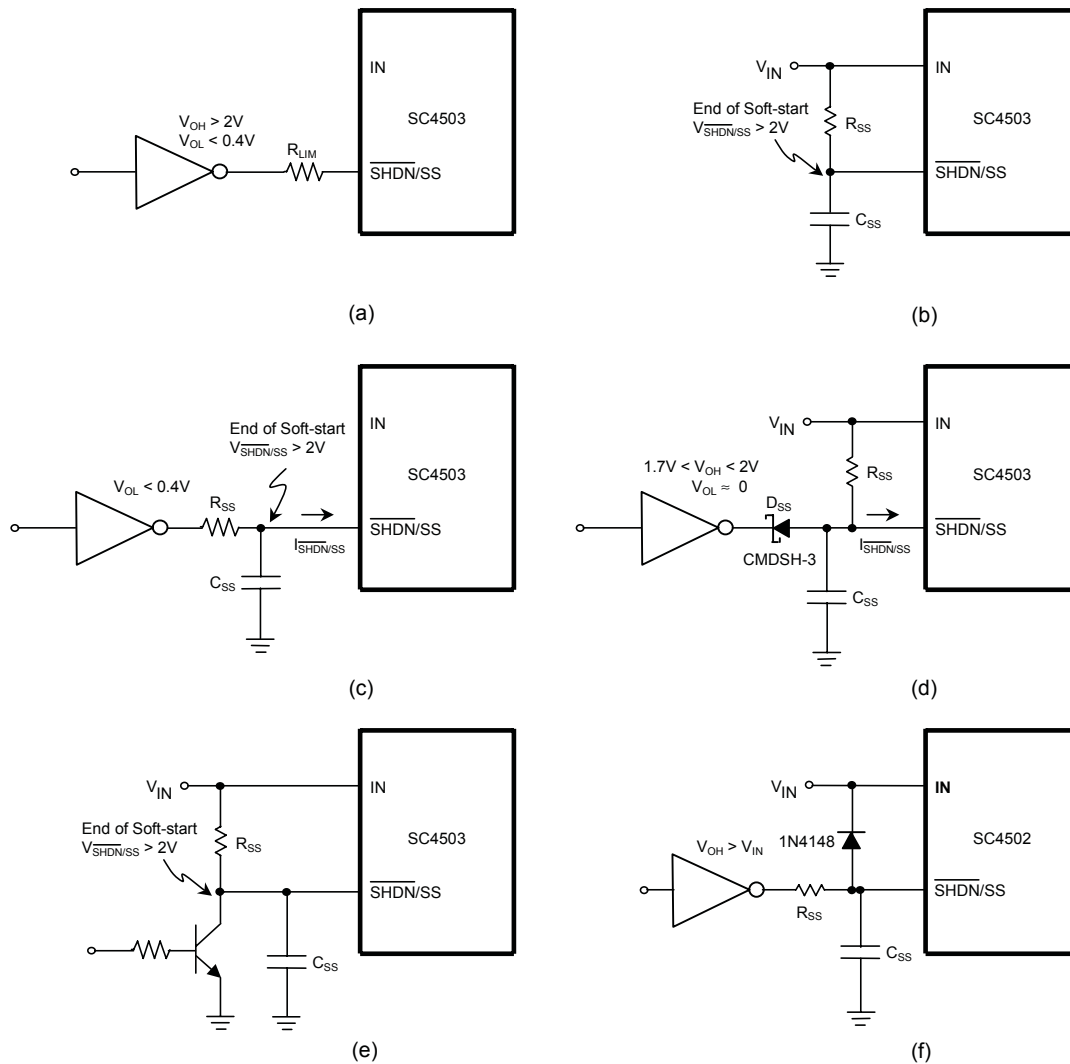

Figure 5. Methods of Driving the Shutdown Pin and Soft-starting the SC4503
 (a) Directly Driven from a Logic Gate. R_{LIM} Limits the Gate Output Current during Fault,
 (b) Soft-start Only,
 (c) Driven from a Logic Gate with Soft-start,
 (d) Driven from a Logic Gate with Soft-start ($1.7\text{V} < V_{OH} < 2\text{V}$),
 (e) Driven from an Open-collector NPN Transistor with Soft-start and
 (f) Driven from a Logic Gate (whose $V_{OH} > V_{IN}$) with Soft-start.

POWER MANAGEMENT

Applications Information (Cont.)

circuit from the driving logic gate during fault condition. In Figure 5(f) the shutdown pin is driven from a logic gate whose V_{OH} is higher than the supply voltage to the SC4503. The diode clamps the maximum shutdown pin voltage to one diode voltage above the input power supply.

During soft-start, C_{SS} is charged by the difference between the R_{SS} current and the shutdown pin current, $I_{SHDN/SS}$. In steady state, the voltage drop across R_{SS} reduces the shutdown pin voltage according to the following equation:

$$V_{SHDN/SS} = V_{EN} - R_{SS} I_{SHDN/SS} \quad (14)$$

In order for the SC4503 to achieve its rated switch current, $V_{SHDN/SS}$ must be greater than 2V in steady state. This puts an upper limit on R_{SS} for a given enable voltage V_{EN} (= voltage applied to R_{SS}). The maximum specified $I_{SHDN/SS}$ is 50 μ A with $V_{SHDN/SS} = 2V$ (see “Electrical Characteristics”). The largest R_{SS} can be found using (14):

$$R_{SS} < \frac{V_{EN(MIN)} - 2}{50\mu A}$$

If the enable signal is less than 2V, then the interfacing options shown in Figures 5(d) and 5(e) will be preferred. The methods shown in Figures 5(a) and 5(c) can still be used however the switch current limit will be reduced. Variations of $I_{SHDN/SS}$ and switch current limit with $V_{SHDN/SS}$ pin voltage and temperature are shown in the “Typical Characteristics”. Shutdown pin current decreases as temperature increases. Switch current limit at a given $V_{SHDN/SS}$ also decreases as temperature rises. Lower shutdown pin current flowing through R_{SS} at high temperature results in higher shutdown pin voltage. However reduction in switch current limit (at a given $V_{SHDN/SS}$) at high temperature is the dominant effect.

Feed-Forward Compensation

Figure 6 shows the equivalent circuit of a boost converter. Important poles and zeros of the overall loop response are:

Low frequency integrator pole, $\omega_{p1} = -\frac{1}{R_0 C_C}$,

Output filter pole, $\omega_{p2} = -\frac{2I_{OUT}}{V_{OUT} C_2} = -\frac{2}{RC_2}$,

Compensating zero, $\omega_{z1} = -\frac{1}{R_C C_C}$ and

Right half plane (RHP) zero, $\omega_{z2} = \frac{R(1-D)^2}{L}$.

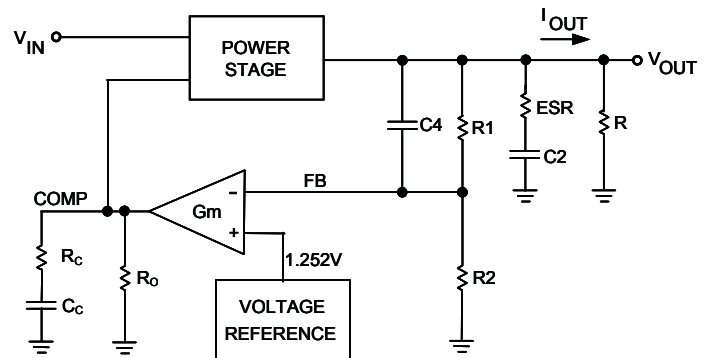

R_0 is the equivalent output resistance of the error amplifier

Figure 6. Simplified Equivalent Model of a Boost Converter

The poles p_1 , p_2 and the RHP zero z_2 all increase phase shift in the loop response. For stable operation, the overall loop gain should cross 0dB with -20dB/decade slope. Due to the presence of the RHP zero, the 0dB crossover frequency should not be more than $\frac{\omega_{z2}}{3}$. The internal compensating zero z_1 provides phase boost beyond p_2 . In general the converter is more stable with widely spaced filter pole p_2 and the RHP zero z_2 . The RHP zero moves to low frequency when either the duty-cycle D or the output current I_{OUT} increases. It is beneficial to use small inductors and larger output capacitors especially when operating at high $\frac{V_{OUT}}{V_{IN}}$ ratios.

A feed-forward capacitor C_4 is needed for stability. The value of C_4 can be determined empirically by observing the inductor current and the output voltage during load transient. Starting with a value between $\frac{1.5\mu s}{R_1}$ and $\frac{6.5\mu s}{R_1}$, C_4 is adjusted until there is no excessive ringing or overshoot in inductor current and output voltage during load transient. Sizing the inductor such that its ripple current is about 0.5A also improves phase margin and transient response.

POWER MANAGEMENT

Applications Information (Cont.)

Figures 7(a)-7(c) show the effects of different values of inductance and feed-forward capacitance on transient responses. In a battery-operated system if C_4 is optimized for the minimum V_{IN} and the maximum load step, the converter will be stable over the entire input voltage range.

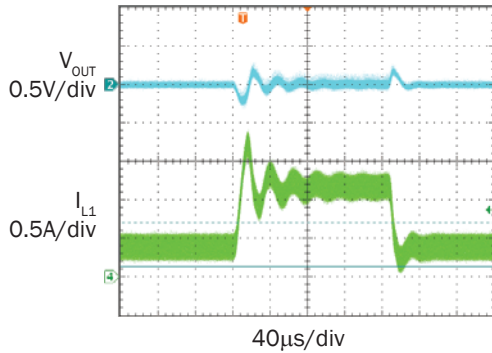

(a) $L_1 = 5.6\mu\text{H}$ and $C_4 = 2.2\text{pF}$

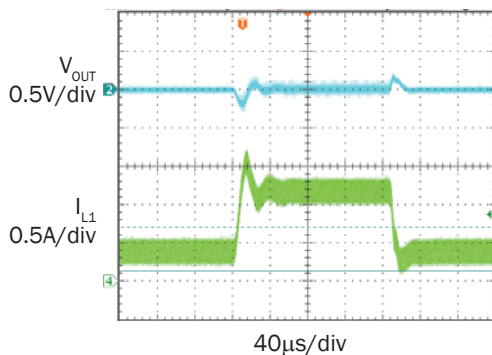

(b) $L_1 = 5.6\mu\text{H}$ and $C_4 = 3.3\text{pF}$

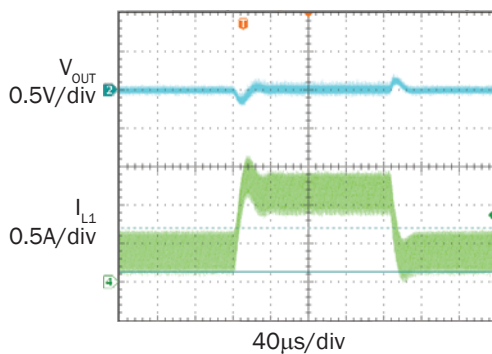

(c) $L_1 = 3.3\mu\text{H}$ and $C_4 = 2.7\text{pF}$

Figure 7. Different inductances and feed-forward capacitances affect the load transient responses of the 3.3V to 12V step-up converter in Figure 10(a). I_{OUT} is switched between 90mA and 280mA.

Board Layout Considerations

In a step-up switching regulator, the output filter capacitor, the main power switch and the rectifying diode carry pulse currents with high di/dt. For jitter-free operation, the size of the loop formed by these components should be minimized. Since the power switch is integrated inside the SC4503, grounding the output filter capacitor next to the SC4503 ground pin minimizes size of the high di/dt current loop. The input bypass capacitors should also be placed close to the input pins. Shortening the trace at the SW node reduces the parasitic trace inductance. This not only reduces EMI but also decreases switching voltage spikes.

Figure 8 shows how various external components are placed around the SC4503.

The large surrounding ground plane acts as a heat sink for the device.

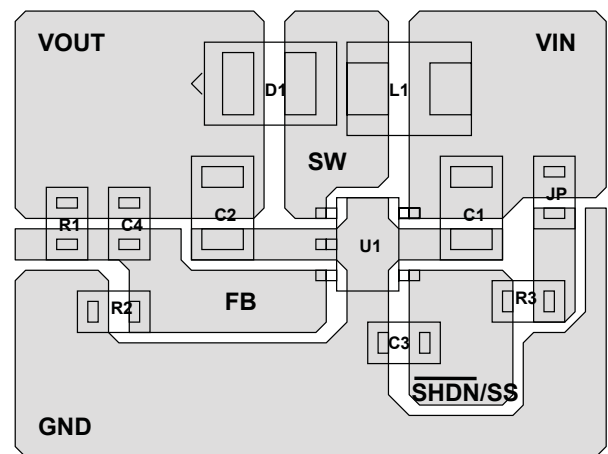
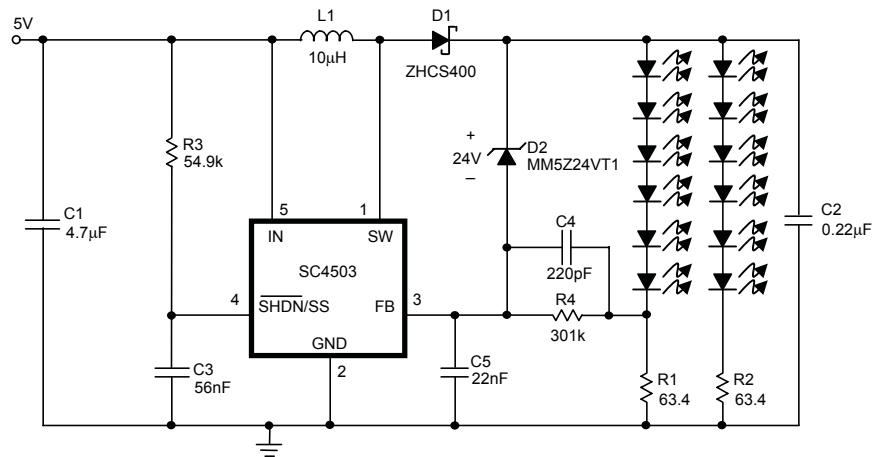

Figure 8. Suggested PCB Layout for the SC4503.



L1: Murata LQH32C

C1: Murata GRM219R60J475K

Figure 9. Driving Two 6 White LED Strings from 5V. Zener diode D_2 protects the converter from over-voltage damage when both LED strings become open.

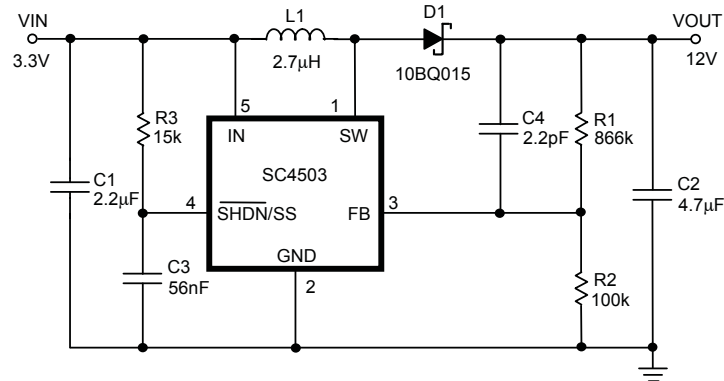

L1: Coiltronics LD1
 C1: Murata GRM188R61A225K
 C2: Murata GRM21BR61C475K

Figure 10(a). 3.3V to 12V Boost Converter with Soft-start

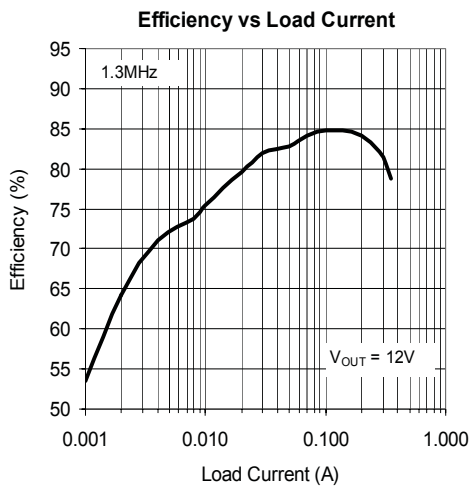
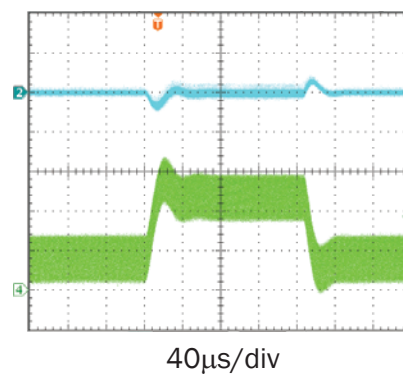

Figure 10(b). Efficiency vs Load Current



Upper Trace : Output Voltage, AC Coupled, 0.5V/div
 Lower Trace : Input Inductor Current, 0.5A/div

Figure 10(c). Load Transient Response of the Circuit in Figure 10(a). I_{OUT} is switched between 90mA and 280mA

POWER MANAGEMENT

Typical Application Circuits

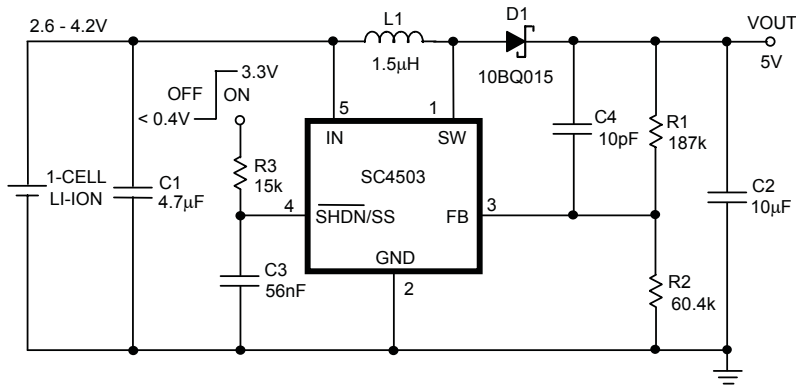

L1: TDK VLF4012AT
C1: Murata GRM188R60J475K
C2: Murata GRM21BR60J106K

Figure 11(a). Single Li-ion Cell to 5V Boost Converter

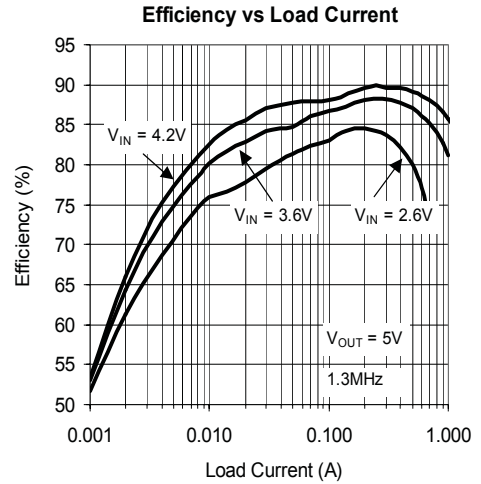
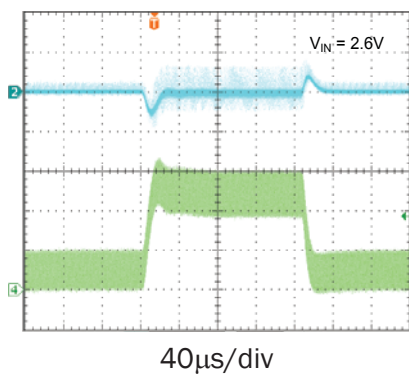
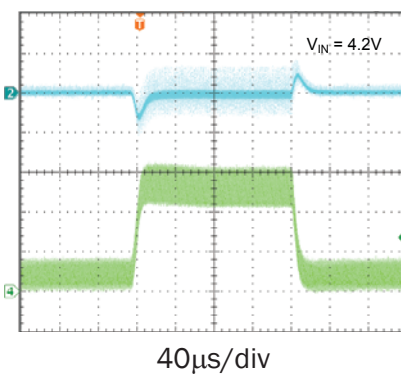

Figure 11(b). Efficiency of the Li-ion Cell to 5V Boost Converter



Upper Trace : Output Voltage, AC Coupled, 0.2V/div
Lower Trace : Inductor Current, 0.5A/div

Figure 11(c). Load Transient Response. I_{OUT} is switched between 0.1A and 0.5A



Upper Trace : Output Voltage, AC Coupled, 0.2V/div
Lower Trace : Inductor Current, 0.5A/div

Figure 11(d). Load Transient Response. I_{OUT} is switched between 0.15A and 0.9A

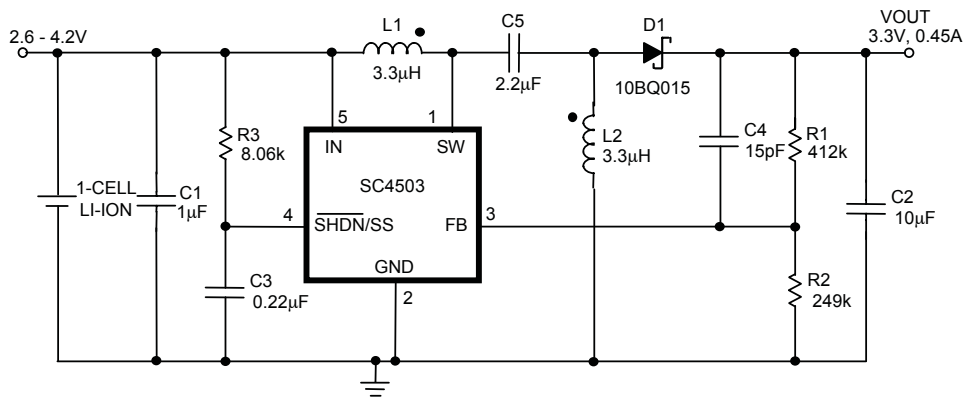

L1 and L2: Coiltronics DRQ73-3R3
 C1: Murata GRM188R61A105K
 C2: Murata GRM21BR60J106K
 C5: Murata GRM188R61A225K

Figure 12(a). Single Li-ion Cell to 3.3V SEPIC Converter.

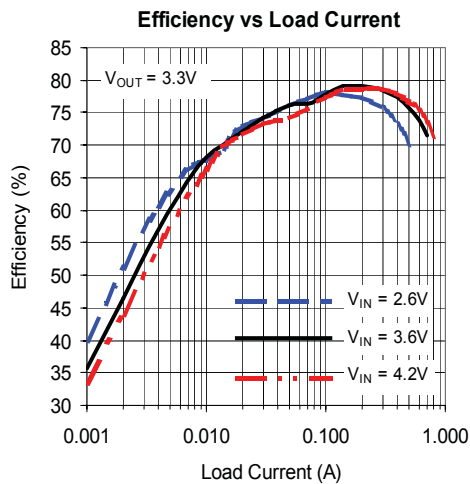
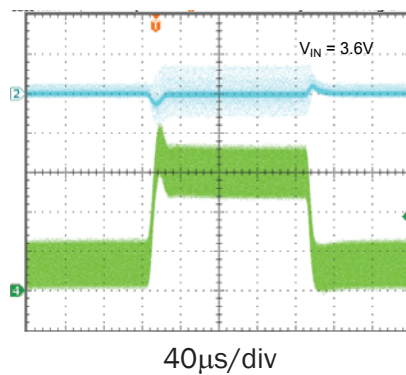

Figure 12(b). Efficiency vs Load Current



Upper Trace : Output Voltage, AC Coupled, 0.2V/div
 Lower Trace : Input Inductor Current, 0.2A/div

Figure 12(c). Load Transient Response of the Circuit in Figure 12(a). I_{OUT} is switched between 100mA and 500mA

POWER MANAGEMENT

Typical Application Circuits

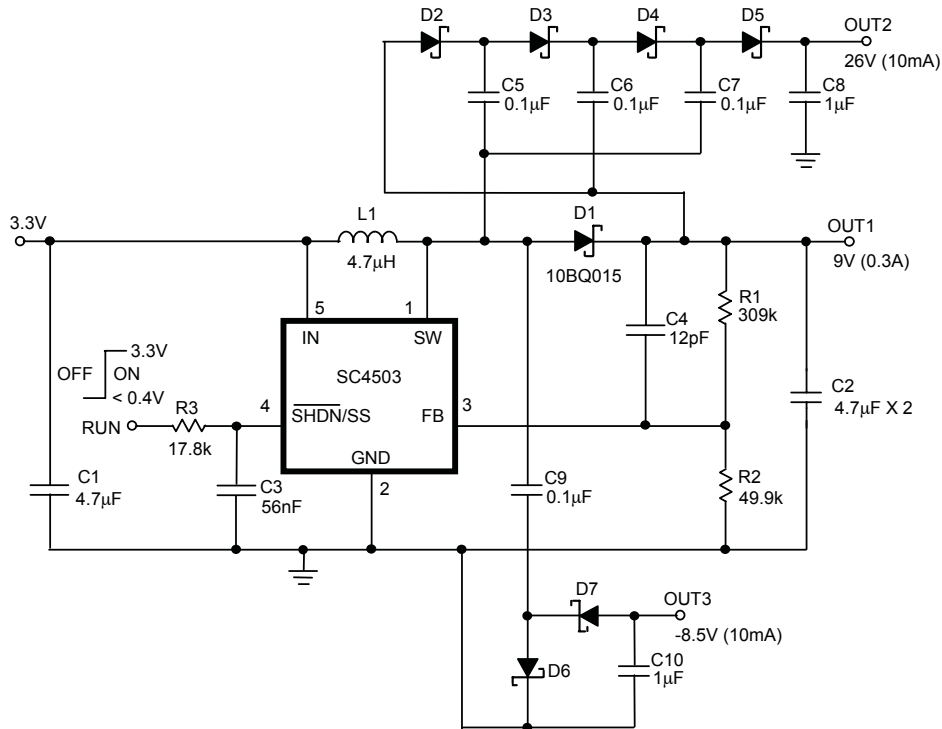

D2 - D7 : BAT54S
L1 : Sumida CDC5D23B-4R7M
C2: Murata GRM21BR61C475K
C1: Murata GRM188R61A105K

Figure 13(a). Triple-Output TFT Power Supply with Soft-Start

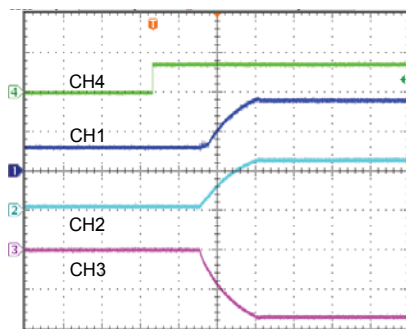

CH1 : OUT1 Voltage, 5V/div
CH2 : OUT2 Voltage, 20V/div
CH3 : OUT3 Voltage, 5V/div
CH4 : RUN Voltage, 5V/div

Figure 13(b). TFT Power Supply Start-up Transient as the RUN Voltage is Stepped from 0 to 3.3V

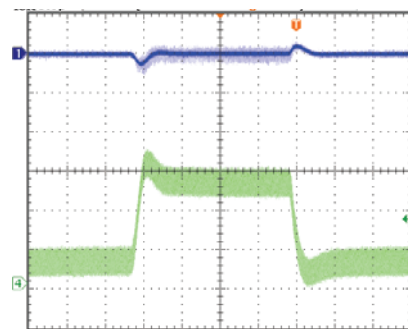

Upper Trace : Output Voltage, AC Coupled, 0.5V/div
Lower Trace : Inductor Current, 0.5A/div

Figure 13(c). Load Transient Response. I_{OUT1} is switched between 50mA and 350mA

POWER MANAGEMENT

EVB Schematic

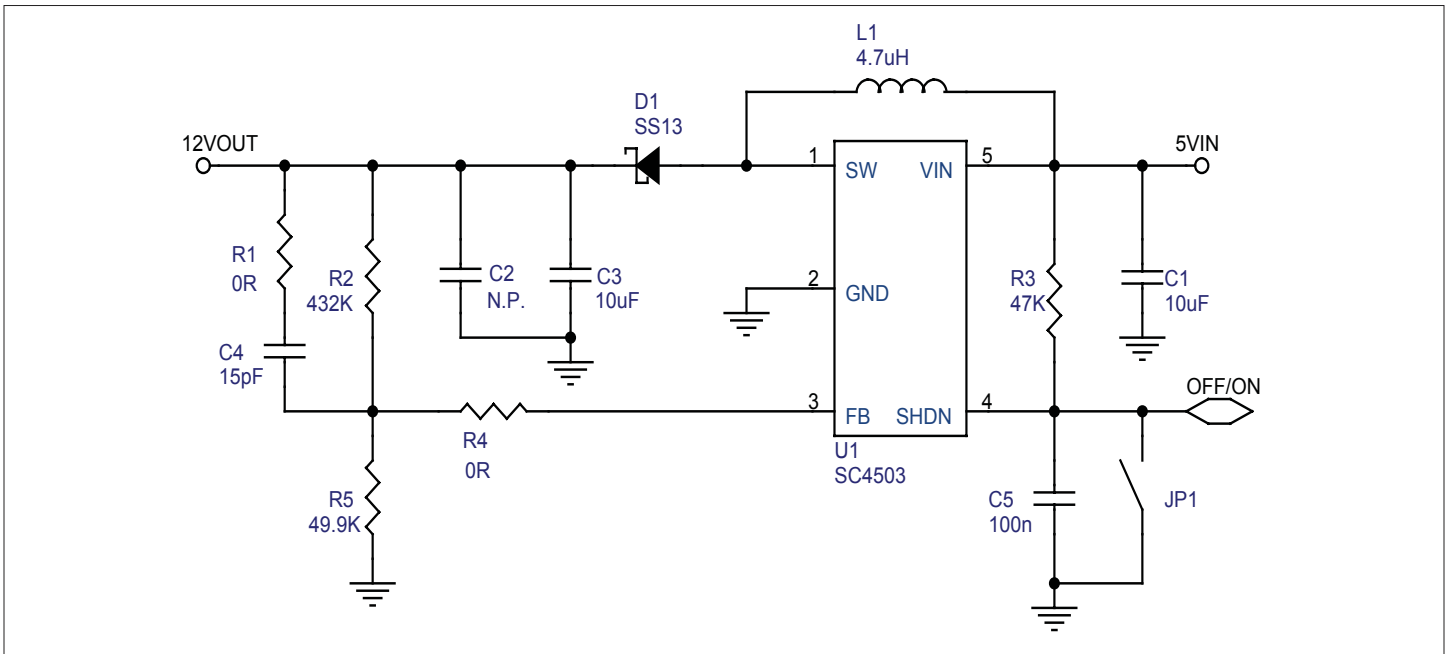
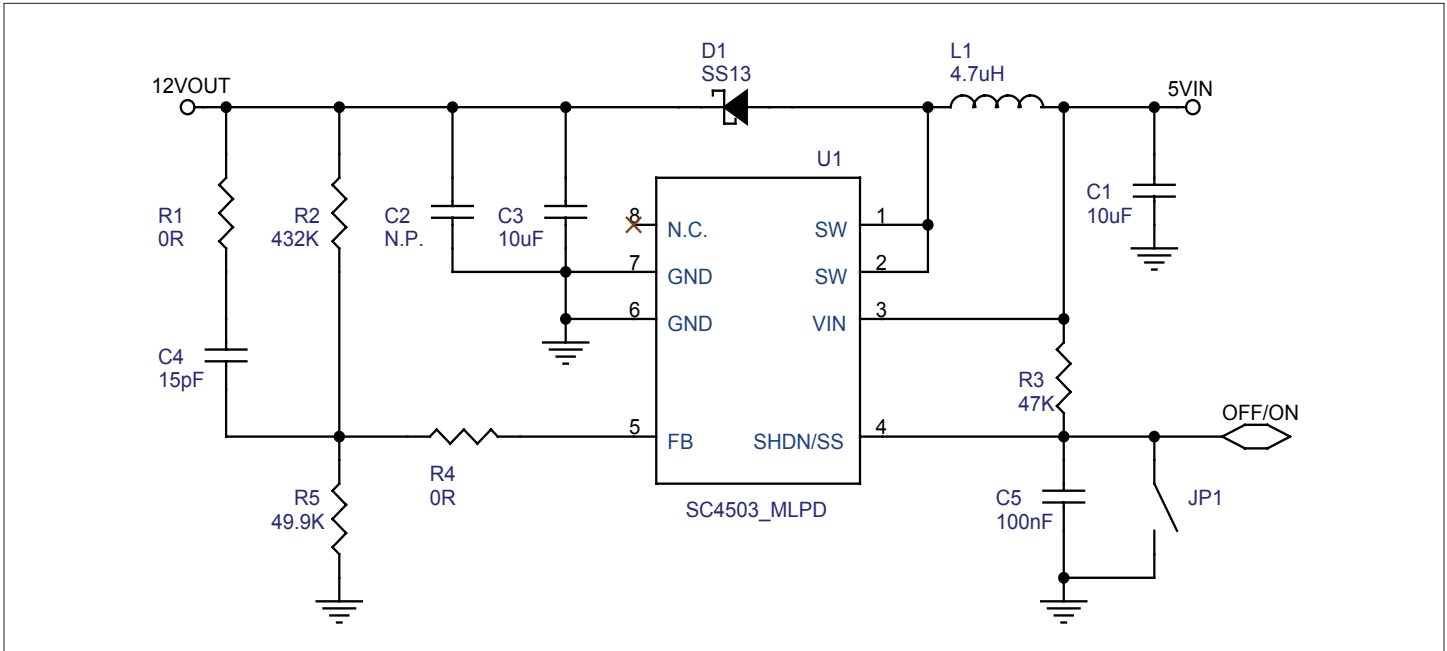

POWER MANAGEMENT

Outline Drawing - TSOT-23

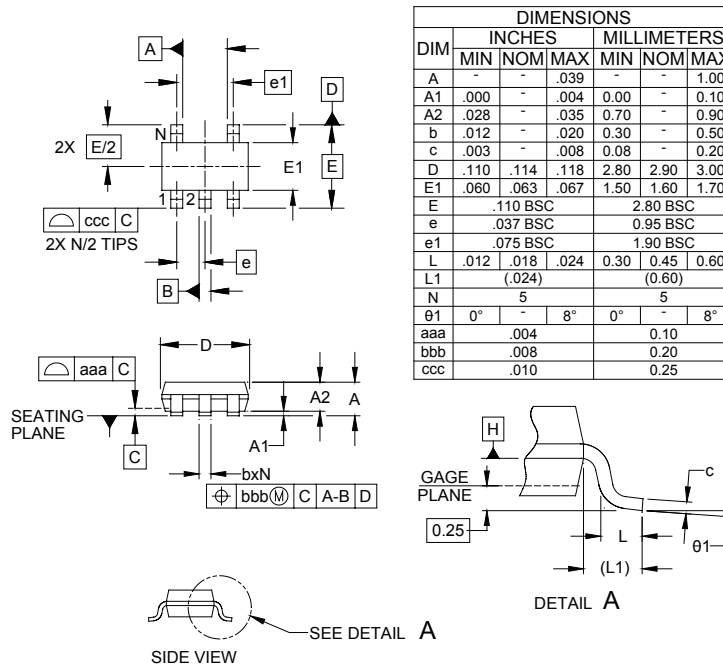

- NOTES:
1. CONTROLLING DIMENSIONS ARE IN MILLIMETERS (ANGLES IN DEGREES).
 2. DATUMS [-A-] AND [-B-] TO BE DETERMINED AT DATUM PLANE [-H-]
 3. DIMENSIONS "E1" AND "D" DO NOT INCLUDE MOLD FLASH, PROTRUSIONS OR GATE BURRS.
 4. REFERENCE JEDEC STD MO-193, VARIATION AB.

Land Pattern - TSOT-23

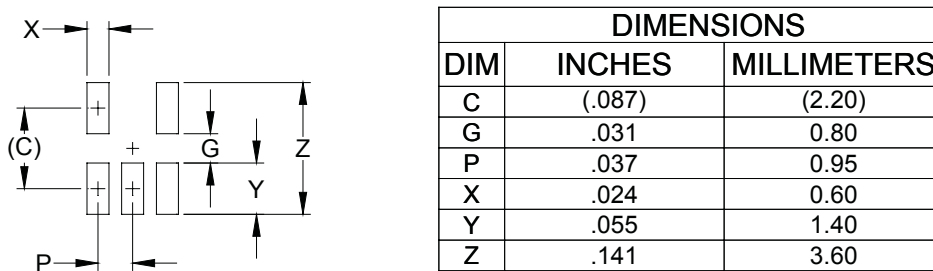

- NOTES:
1. THIS LAND PATTERN IS FOR REFERENCE PURPOSES ONLY. CONSULT YOUR MANUFACTURING GROUP TO ENSURE YOUR COMPANY'S MANUFACTURING GUIDELINES ARE MET.

POWER MANAGEMENT

Outline Drawing - 8 Lead 2X2mm MLPD-W

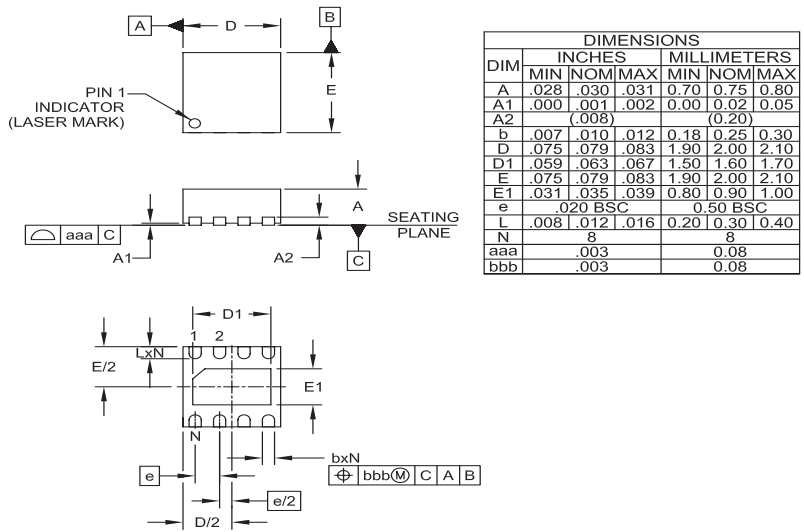

- NOTES:
1. CONTROLLING DIMENSIONS ARE IN MILLIMETERS (ANGLES IN DEGREES).
 2. COPLANARITY APPLIES TO THE EXPOSED PAD AS WELL AS THE TERMINALS.

Land Pattern - 8 Lead 2X2mm MLPD-W

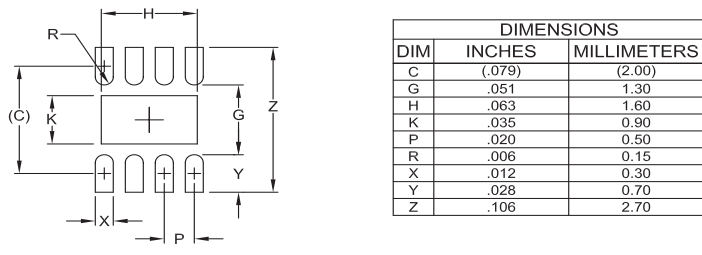

- NOTES:
1. CONTROLLING DIMENSIONS ARE IN MILLIMETERS (ANGLES IN DEGREES).
 2. THIS LAND PATTERN IS FOR REFERENCE PURPOSES ONLY. CONSULT YOUR MANUFACTURING GROUP TO ENSURE YOUR COMPANY'S MANUFACTURING GUIDELINES ARE MET.
 3. THERMAL VIAS IN THE LAND PATTERN OF THE EXPOSED PAD SHALL BE CONNECTED TO A SYSTEM GROUND PLANE. FAILURE TO DO SO MAY COMPROMISE THE THERMAL AND/OR FUNCTIONAL PERFORMANCE OF THE DEVICE.

Contact Information

Taiwan Branch
Tel: 886-2-2748-3380
Fax: 886-2-2748-3390

Semtech Switzerland GmbH
Japan Branch

Tel: 81-3-6408-0950
Fax: 81-3-6408-0951

Korea Branch
Tel: 82-2-527-4377
Fax: 82-2-527-4376

Semtech Limited (U.K.)

Tel: 44-1794-527-600
Fax: 44-1794-527-601

Shanghai Office
Tel: 86-21-6391-0830
Fax: 86-21-6391-0831

Semtech France SARL

Tel: 33-(0)169-28-22-00
Fax: 33-(0)169-28-12-98

Semtech International AG is a wholly-owned subsidiary of Semtech Corporation, which has its headquarters in the U.S.A.

Semtech Germany GmbH

Tel: 49-(0)8161-140-123
Fax: 49-(0)8161-140-124

X-ON Electronics

Largest Supplier of Electrical and Electronic Components

Click to view similar products for [Switching Voltage Regulators](#) category:

Click to view products by [Semtech](#) manufacturer:

Other Similar products are found below :

[FAN53610AUC33X](#) [FAN53611AUC123X](#) [FAN48610BUC33X](#) [FAN48610BUC45X](#) [FAN48617UC50X](#) [R3](#) [430464BB](#) [KE177614](#)
[FAN53611AUC12X](#) [MAX809TTR](#) [NCV891234MW50R2G](#) [NCP81103MNTXG](#) [NCP81203PMNTXG](#) [NCP81208MNTXG](#)
[NCP81109GMNTXG](#) [SCY1751FCCT1G](#) [NCP81109JMNTXG](#) [AP3409ADNTR-G1](#) [NCP81241MNTXG](#) [LTM8064IY](#) [LT8315EFE#TRPBF](#)
[LTM4664EY#PBF](#) [LTM4668AIY#PBF](#) [NCV1077CSTBT3G](#) [XCL207A123CR-G](#) [MPM54304GMN-0002](#) [MPM54304GMN-0004](#)
[MPM54304GMN-0003](#) [AP62300Z6-7](#) [MP8757GL-P](#) [MIC23356YFT-TR](#) [LD8116CGL](#) [HG2269M/TR](#) [OB2269](#) [XD3526](#) [U6215A](#) [U6215B](#)
[U6620S](#) [LTC3412IFE](#) [LT1425IS](#) [MAX25203BATJA/VY+](#) [MAX77874CEWM+](#) [XC9236D08CER-G](#) [MP3416GJ-P](#) [BD9S201NUX-CE2](#)
[MP5461GC-Z](#) [MPQ4415AGQB-Z](#) [MPQ4590GS-Z](#) [MAX38640BENT18+T](#) [MAX77511AEWB+](#)