

### POWER MANAGEMENT

#### Features

- Input voltage range — 1.7V to 5.5V
- 4A continuous output current
- Ultra-Low  $R_{dson}$  — 8 m $\Omega$
- Constant  $R_{dson}$  over wide  $V_{IN}$  range
- Optional output discharge circuit
  - SC701 — Automatic output discharge
  - SC701H — No output discharge circuit
- Low shutdown current
- Low quiescent current
- Package: CSP — 0.9mm x 1.4mm , 0.5mm Pitch

#### Applications

- Battery powered equipment
- Smart Phones/Tablet PCs
- Consumer electronics
- STB/Audio/Video
- Industrial/Network equipment
- Other Portable Devices

#### Description

The SC701/SC701H is an ultra-low  $R_{dson}$  load switch optimized for use in battery powered applications. SC701/SC701H supports up to 4A continuous output current. Sophisticated integrated circuitry maximizes  $V_{gs}$  of the power NMOS to minimize  $R_{dson}$  resistance over a wide range of operating conditions.

The device provides a controlled soft-start to limit inrush current. SC701 features an automatic discharge circuit which discharges the output when the SC701 is disabled. SC701H does not include automatic output discharge circuitry.

The SC701/SC701H is offered in an ultra small 6-bump 0.9mm x 1.4mm Chip Scale Package (CSP) which enables very small board area implementations. The SC701/SC701H has an operating temperature range of -40°C to +85°C.

### Typical Application Circuit

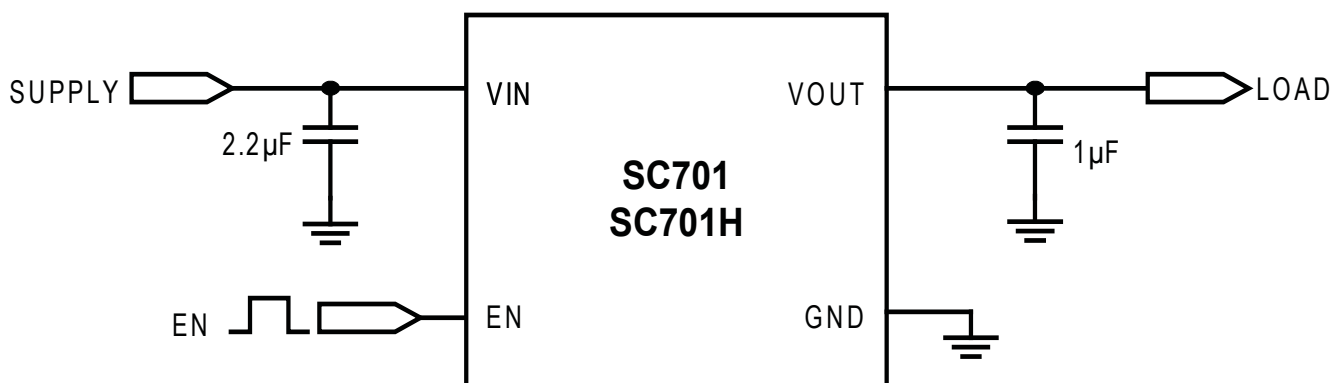

## Pin Configuration

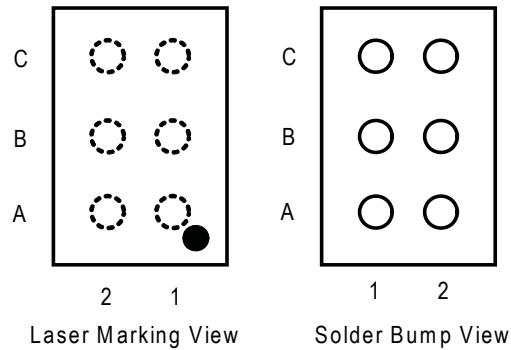

## Terminals Assignments

	1	2
C	GND	EN
B	VOUT	VIN
A	VOUT	VIN

## Marking Information

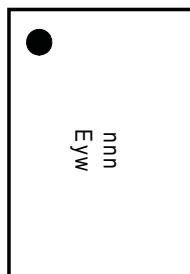

- nnn = Part No. Code — SC701: MR7
- nnn = Part No. Code — SC701H: MRH
- Eyw = Datecode — Example: EOW

## Ordering Information

Device	Package
SC701CSTRT <sup>(1)</sup> <sup>(2)</sup>	CSP 0.9mm × 1.4mm, 6-Bump
SC701HCSTRT <sup>(1)</sup> <sup>(2)</sup>	CSP 0.9mm × 1.4mm, 6-Bump
SC701/SC701H-EVB	Evaluation Board

### Notes:

- (1) Available in tape and reel only. A reel contains 3,000 devices.
- (2) Lead-free package only. Device is WEEE and RoHS compliant.

## Absolute Maximum Ratings

V <sub>IN</sub> (V) .....	-0.3 to +6.0
EN (V) .....	-0.3 to +6.0
V <sub>OUT</sub> (V) .....	-0.3 to (V <sub>IN</sub> + 0.3)
ESD HBM Protection Level <sup>(1)</sup> .....	Class 1C

## Recommended Operating Conditions

Ambient Temperature Range (°C) .....	-40 ≤ T <sub>A</sub> ≤ +85
V <sub>IN</sub> (V) .....	1.7 to 5.5
V <sub>OUT</sub> (V) .....	0 to VIN
Maximum Output Current (A) .....	4

## Thermal Information

Thermal Resistance, Junction to Ambient <sup>(2)</sup> (°C/W) ...	125
Maximum Junction Temperature (°C) .....	+150
Storage Temperature Range (°C) .....	-65 to +150
Peak IR Reflow Temperature (10s to 30s) (°C) .....	+260

Exceeding the above specifications may result in permanent damage to the device or device malfunction. Operation outside of the parameters specified in the Electrical Characteristics section is not recommended.

### NOTES:

(1) Tested according to JEDEC standard JESD22-A114-B.

(2) Calculated from package in still air, mounted to 3 x 4.5 (in), 4 layer FR4 PCB with thermal vias under the exposed pad per JESD51 standards.

## Electrical Characteristics

Unless otherwise noted V<sub>IN</sub> = 5.5V, C<sub>IN</sub> = 2.2μF, C<sub>OUT</sub> = 1μF, V<sub>EN</sub> ≥ V<sub>IH</sub>, T<sub>A</sub> = -40°C to +85°C. Typical values are at T<sub>A</sub> = 25°C.

Parameter	Symbol	Conditions	Min	Typ	Max	Units
ON-state Resistance	R <sub>DSON</sub>	I <sub>OUT</sub> = 500mA, V <sub>IN</sub> = 1.7V		8		mΩ
		I <sub>OUT</sub> = 500mA, V <sub>IN</sub> = 2.5V		8		
		I <sub>OUT</sub> = 500mA, V <sub>IN</sub> = 3.3V		8		
		I <sub>OUT</sub> = 500mA, V <sub>IN</sub> = 3.6V		8		
		I <sub>OUT</sub> = 500mA, V <sub>IN</sub> = 5.5V		8		
		I <sub>OUT</sub> = 500mA, 1.7V ≤ V <sub>IN</sub> ≤ 5.5V			11.2	
Shutdown Current	I <sub>SD</sub>	EN = 0V, 1.7V ≤ V <sub>IN</sub> ≤ 5.5V			3.5	μA
Quiescent Current	I <sub>Q</sub>	1.7V ≤ V <sub>IN</sub> ≤ 5.5V			205	μA
		V <sub>IN</sub> = 3.6V		125		
Pull Down Resistance <sup>(1)</sup>	R <sub>PD</sub>	SC701		1.5		kΩ

**Electrical Characteristics (continued)**

Parameter	Symbol	Conditions	Min	Typ	Max	Units
Turn On Time	$T_{ON}$	From rising edge of EN to 50% of VOUT, $V_{IN} = 1.7V$ , Load = 10 $\Omega$		330		$\mu s$
		From rising edge of EN to 50% of VOUT, $V_{IN} = 3.6V$ , Load = 10 $\Omega$		330		
		From rising edge of EN to 50% of VOUT, $V_{IN} = 5.5V$ , Load = 10 $\Omega$		380		
Rise Time	$T_R$	From 10% to 90% of VOUT, $V_{IN} = 1.7V$ , Load = 10 $\Omega$		200		$\mu s$
		From 10% to 90% of VOUT, $V_{IN} = 3.6V$ , Load = 10 $\Omega$		280		
		From 10% to 90% of VOUT, $V_{IN} = 5.5V$ , Load = 10 $\Omega$		390		
Turn Off Time	$T_{OFF}$	From falling edge of EN to 50% of VOUT, $V_{IN} = 1.7V$ , Load = 10 $\Omega$		11		$\mu s$
		From falling edge of EN to 50% of VOUT, $V_{IN} = 3.6V$ , Load = 10 $\Omega$		10		
		From falling edge of EN to 50% of VOUT, $V_{IN} = 5.5V$ , Load = 10 $\Omega$		9		
Fall Time	$T_F$	From 90% to 10% of VOUT, $V_{IN} = 1.7V$ , Load = 10 $\Omega$		18		$\mu s$
		From 90% to 10% of VOUT, $V_{IN} = 3.6V$ , Load = 10 $\Omega$		19		
		From 90% to 10% of VOUT, $V_{IN} = 5.5V$ , Load = 10 $\Omega$		20		
<b>EN Digital Input</b>						
EN Input High Threshold	$V_{IH}$			0.9	1.05	V
EN Input Low Threshold	$V_{IL}$		0.4			V
Logic Input High Current	$I_{IH}$				0.1	$\mu A$
Logic Input Low Current	$I_{IL}$				0.1	$\mu A$

**Notes:**

(1) SC701: see Output Pull Down operation in Applications Information section.

## Block Diagram

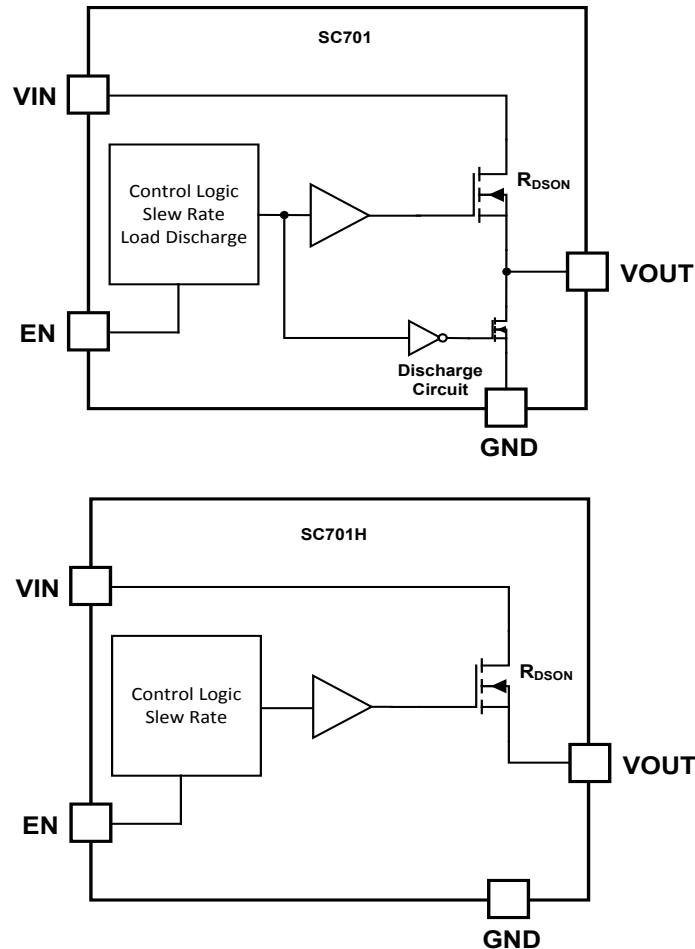

## Pin Descriptions

Pin #	Pin Name	Pin Function
A1, B1	VOUT	Switch output - connect a bypass capacitor of at least 0.1uF to the GND pin. Minimize the PCB layout path inductance for this bypass capacitor between the VOUT pins and the GND pin.
A2, B2	VIN	Switch input - connect a bypass capacitor of at least 1uF to the GND pin. Minimize the PCB layout path inductance for this bypass capacitor between the VIN pins and the GND pin.
C1	GND	Ground reference for SC701/SC701H.
C2	EN	Enable/disable the SC701/SC701H.

## Key Components

Component	Value	Manufacture	Part Number	Website
Input Capacitor	2.2uF/0603/X5R/10V	Murata	GRM188R61A225KE34D	www.murata.com
Output Capacitor	1uF/0603/X5R/10V	Murata	GRM188R61A105KA61J	www.murata.com

**Typical Characteristics:**

Characteristics in this section are based upon using SC701H in the Typical Application Circuit ( $C_{IN} = 2.2\mu F$ ,  $C_{OUT} = 1\mu F$ ).

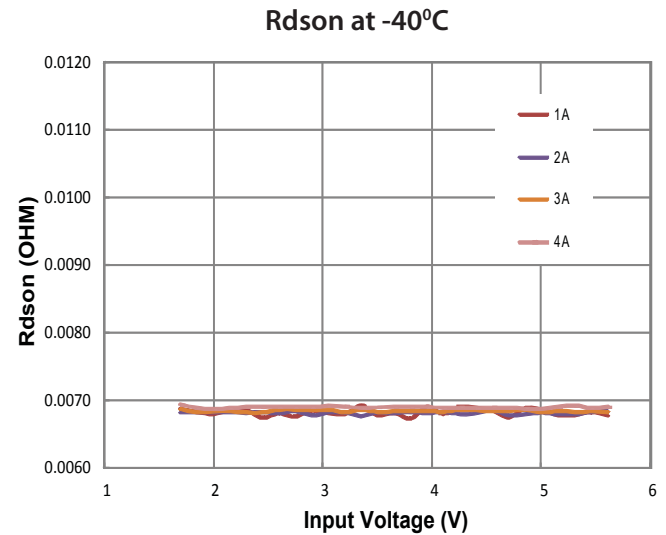
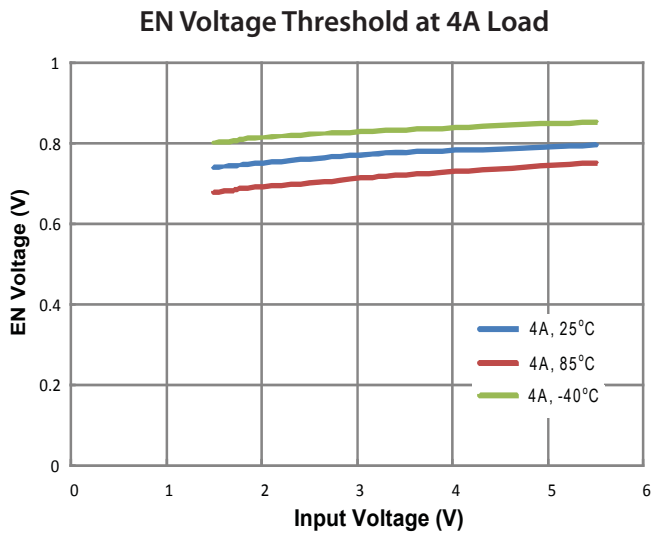
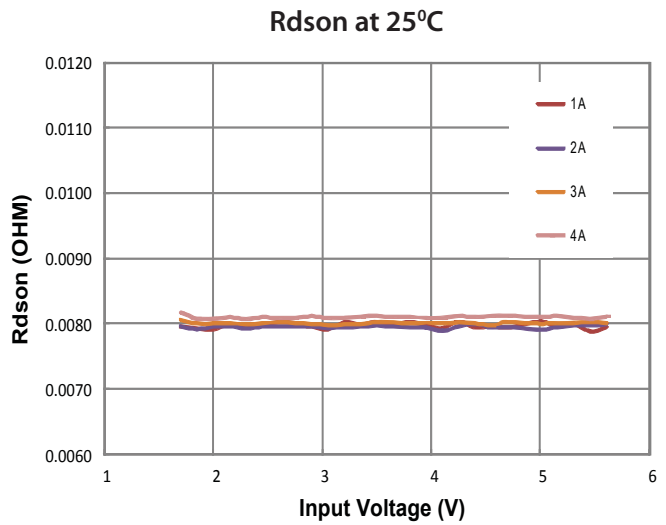
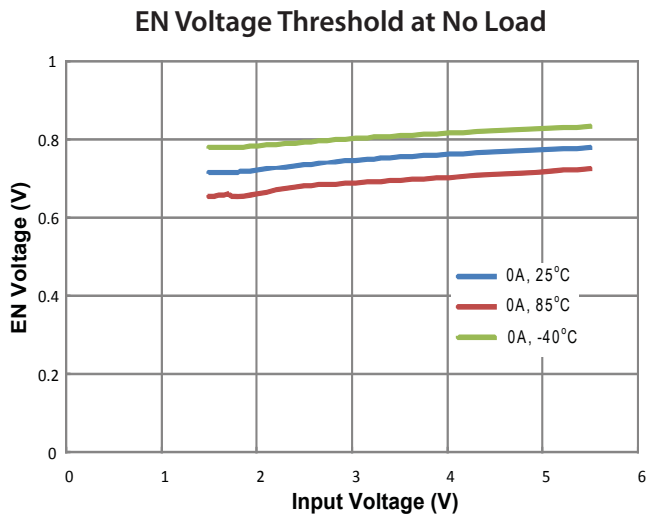
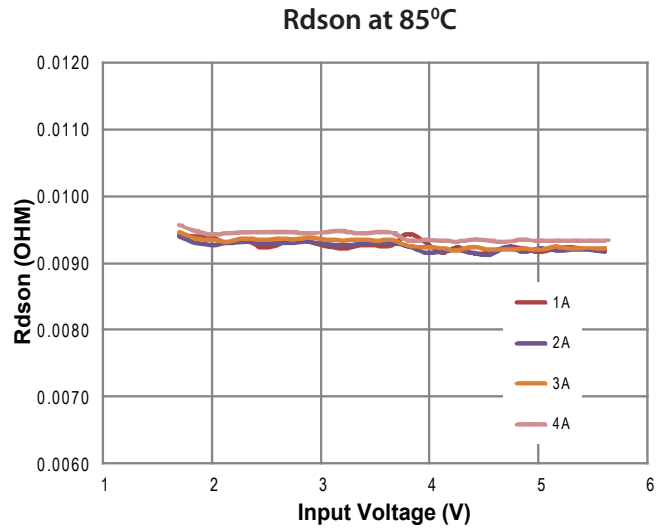
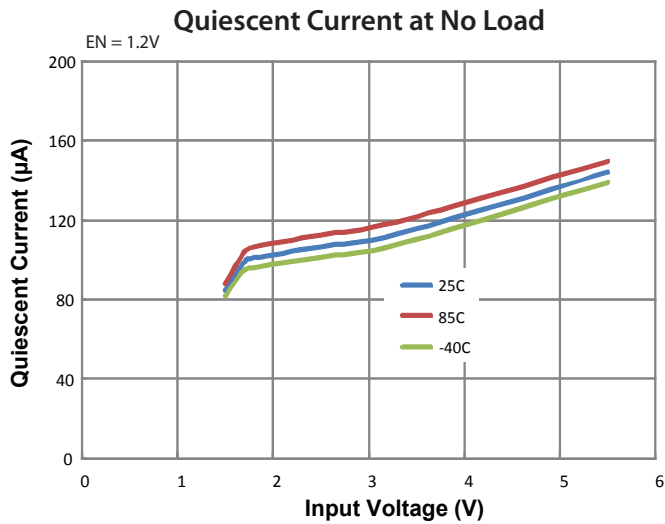

**Parameter Measurement Information**

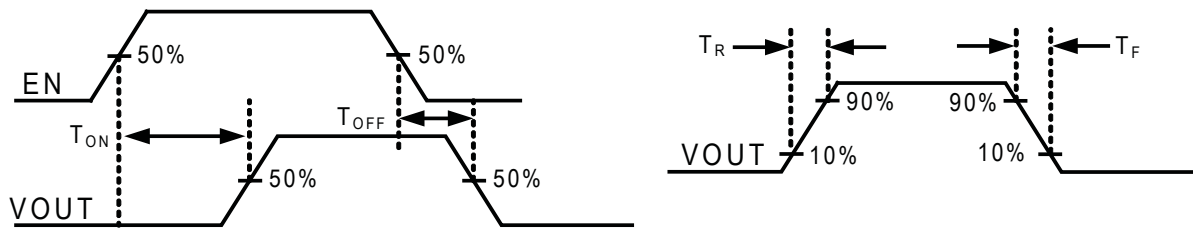
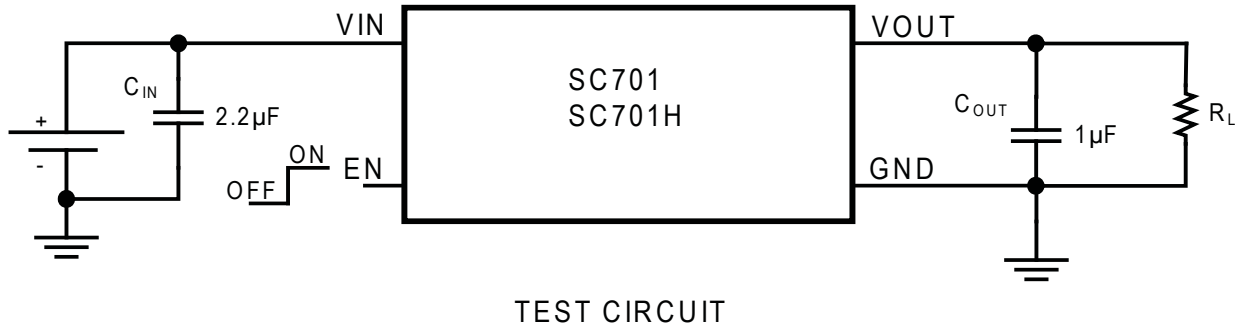

T<sub>ON</sub>, T<sub>OFF</sub>, T<sub>R</sub>, T<sub>F</sub> WAVEFORMS

**Typical Characteristics:**

Characteristics in this section are based upon using SC701H in the Typical Application Circuit ( $C_{IN} = 2.2\mu F$ ,  $C_{OUT} = 1\mu F$ ).

**Turn-On Response at 10 Ohm Load, 1.8V, 25°C**

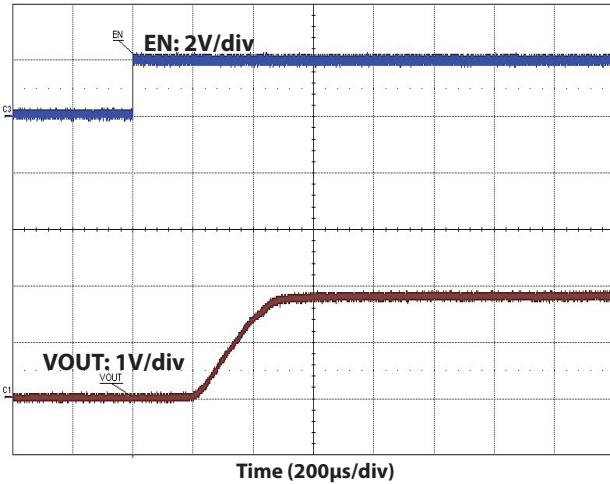

**Turn-Off Response at 10 Ohm Load, 1.8V, 25°C**

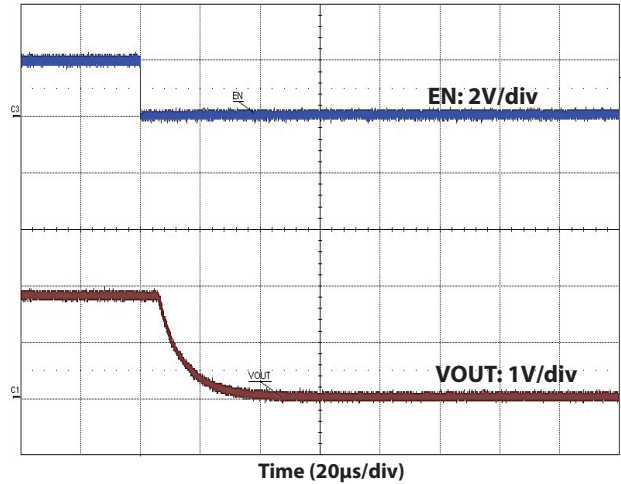

**Turn-On Response at 10 Ohm Load, 3.6V, 25°C**

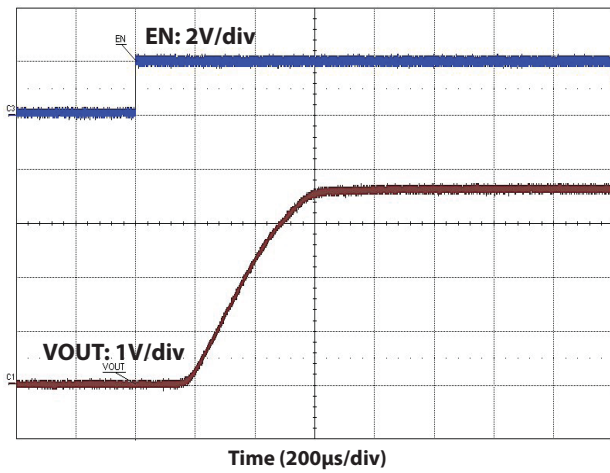

**Turn-Off Response at 10 Ohm Load, 3.6V, 25°C**

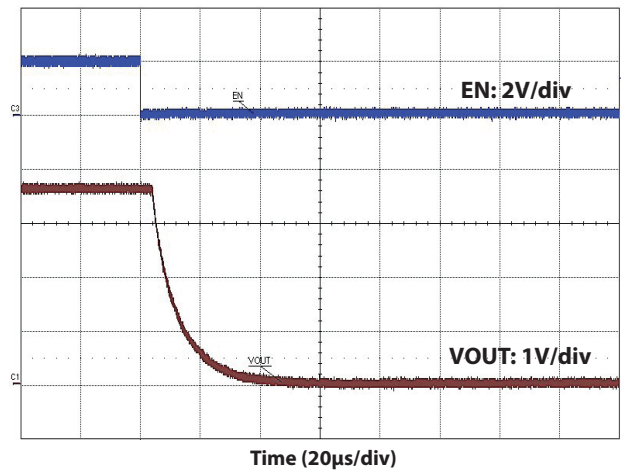

**Turn-On Response at 10 Ohm Load, 5.5V, 25°C**

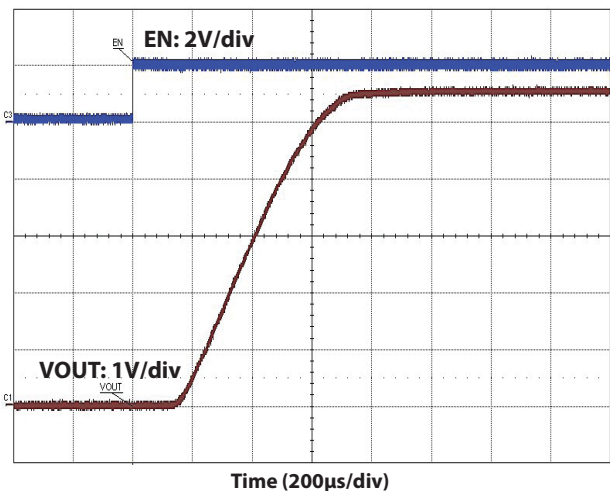

**Turn-Off Response at 10 Ohm Load, 5.5V, 25°C**

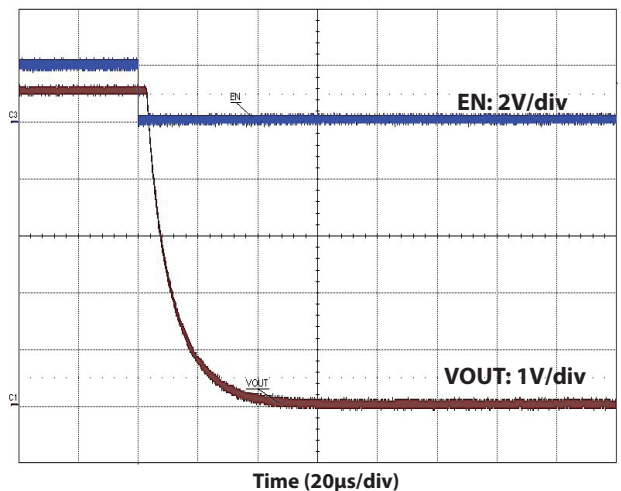



**Typical Characteristics:**

Characteristics in this section are based upon using SC701H in the Typical Application Circuit ( $C_{IN} = 2.2\mu F$ ,  $C_{OUT} = 1\mu F$ ).

**Turn-On Response at 4A Load, 1.8V, 25°C**

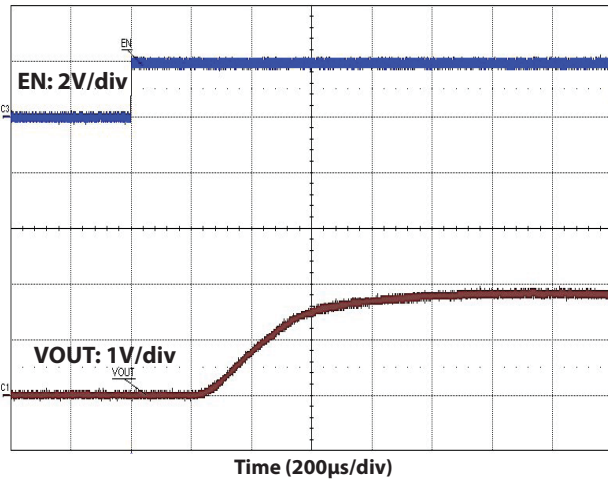

**Turn-Off Response at 4A Load, 1.8V, 25°C**

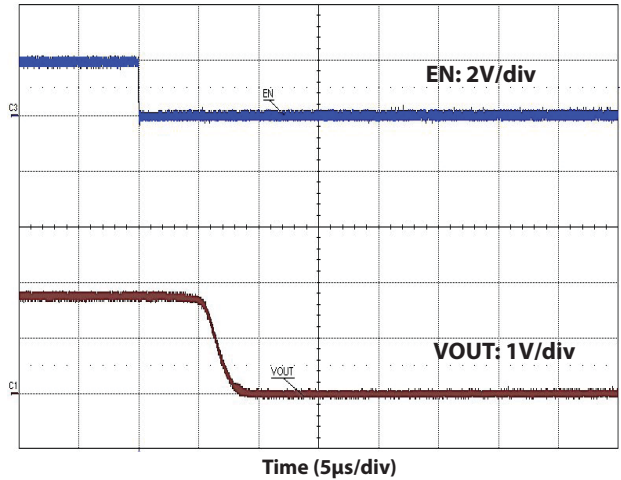

**Turn-On Response at 4A Load, 3.6V, 25°C**

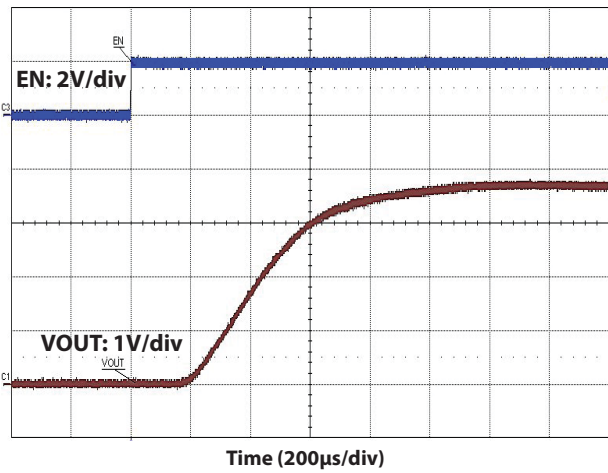

**Turn-Off Response at 4A Load, 3.6V, 25°C**

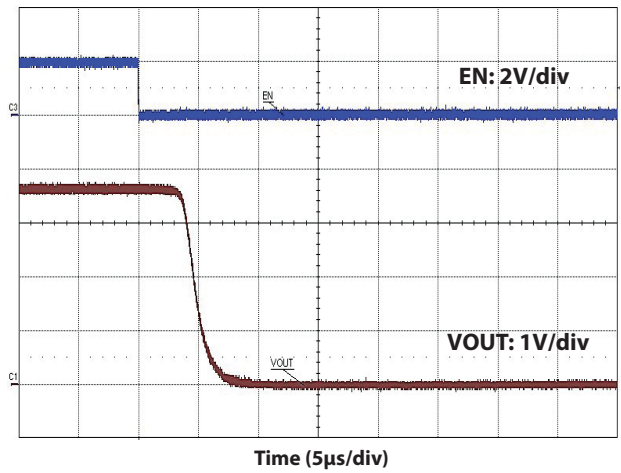

**Turn-On Response at 4A Load, 5.5V, 25°C**

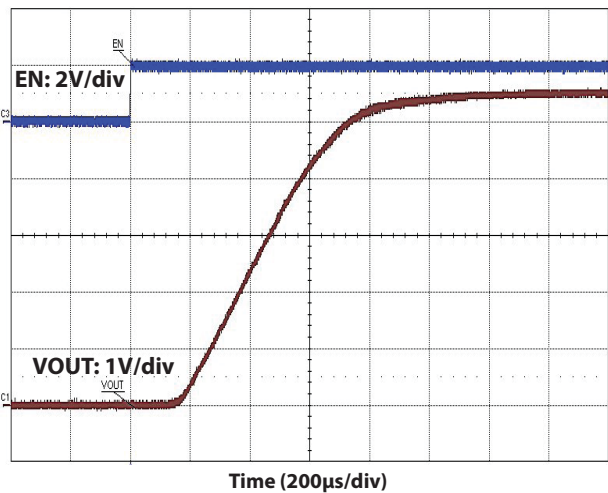

**Turn-Off Response at 4A Load, 5.5V, 25°C**

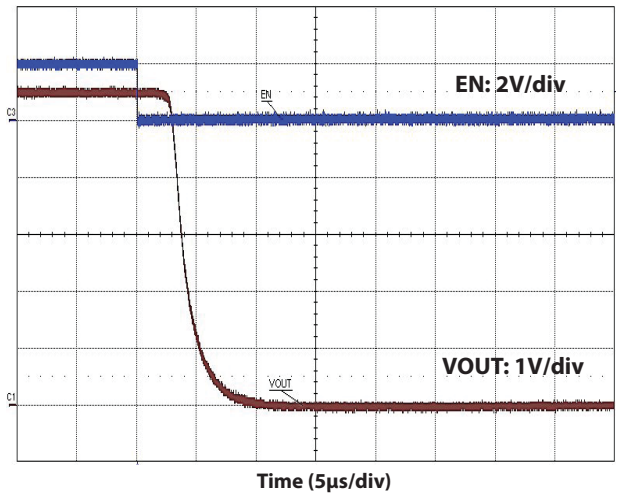

## Typical Characteristics:

Characteristics in this section are based upon using SC701H in the Typical Application Circuit ( $C_{IN} = 2.2\mu F$ ,  $C_{OUT} = 1\mu F$ ).

### Turn-On Time at 10 Ohm Load

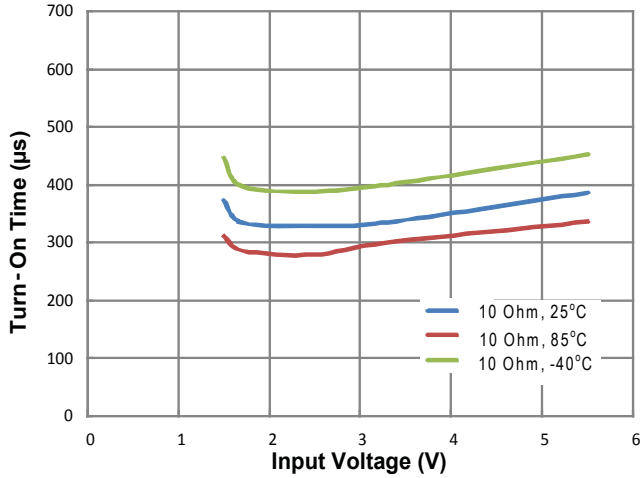

### Turn-On Time at 4A Load

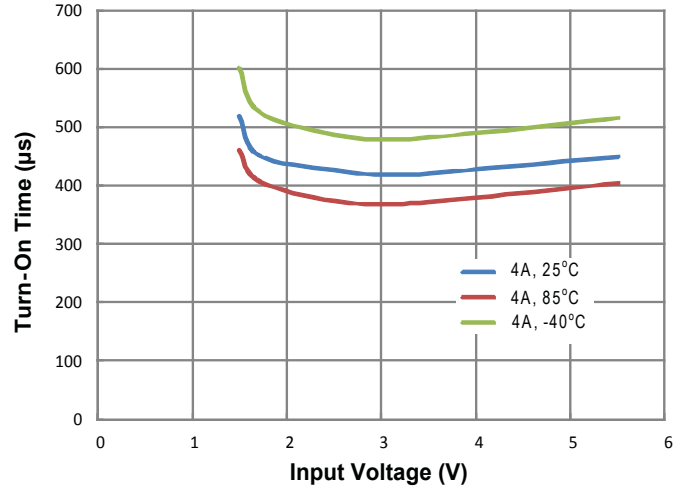

### Turn-Off Time at 10 Ohm Load

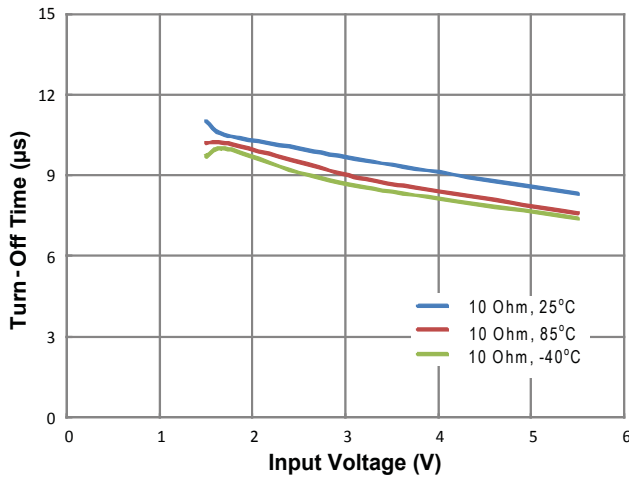

### Turn-Off Time at 4A Load

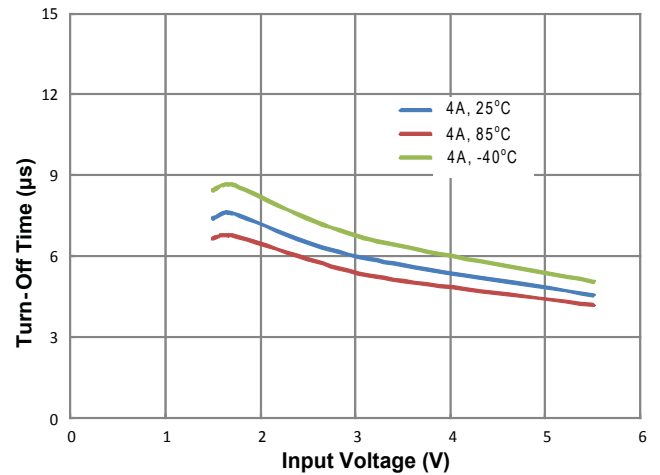

### Rise Time at 10 Ohm Load

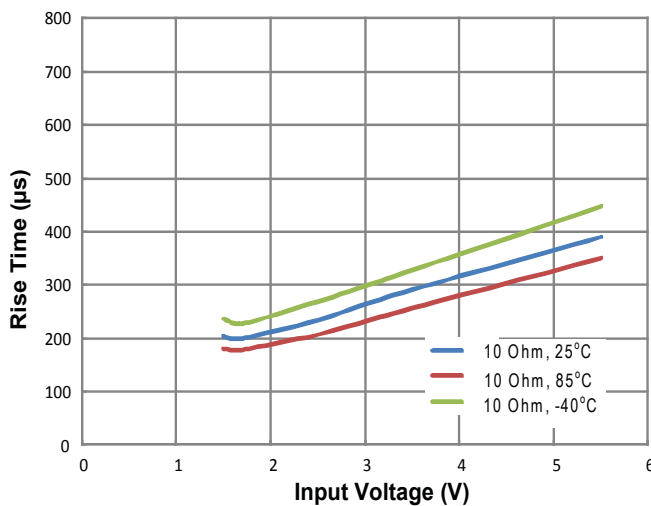

### Rise Time at 4A Load

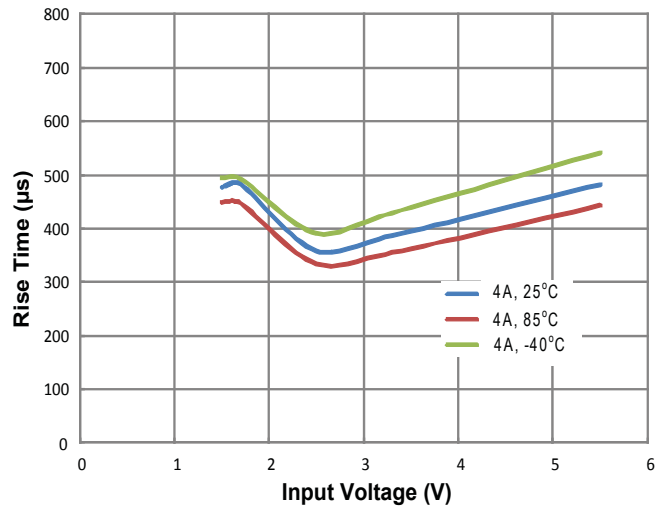

**Typical Characteristics:**

Characteristics in this section are based upon using SC701H in the Typical Application Circuit ( $C_{IN} = 2.2\mu F$ ,  $C_{OUT} = 1\mu F$ ).

**Fall Time at 10 Ohm Load**

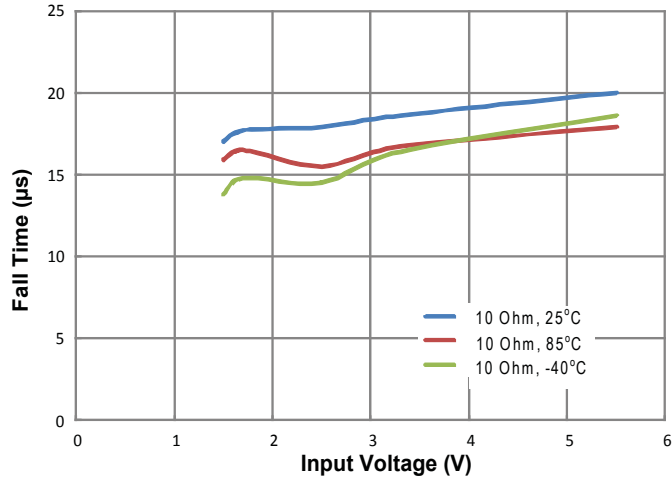

**Fall Time at 4A Load**

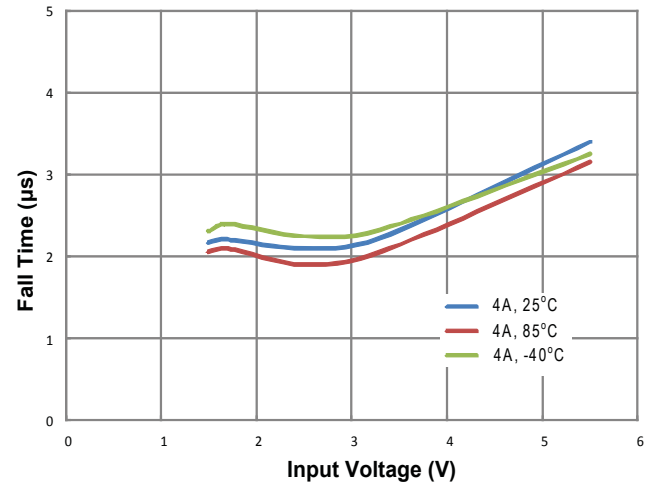

## Applications Information

### 4A Load Switch

The SC701/SC701H is an ultra-low  $R_{ds(on)}$  load switch optimized for use in battery powered applications. SC701/SC701H supports up to 4A continuous output current. Sophisticated integrated circuitry maximizes  $V_{gs}$  of the power NMOS to minimize  $R_{ds(on)}$  resistance over a wide range of operating conditions.

### Input Capacitor

The primary purpose of input capacitance for SC701/SC701H is to hold the voltage at VIN pins constant when the switch is transitioning between open and closed. When the switch is closing, the input capacitor prevents the voltage at VIN from dropping. When the switch is opening, the input capacitor limits voltage spikes.

Ceramic capacitors should be derated for temperature and bias. As a result, applications up to 3.6V should use capacitors rated 6.3V. Applications up to 5.5V should use capacitors rated 10V.

### Output Capacitor

The purpose of output capacitance is to absorb transients on the output.  $C_{in}$  should be selected to be higher in value than  $C_{out}$ . This is because the integrated body diode of the SC701/SC701H does not have reverse voltage protection. If the input supply is removed while the switch is closed,  $C_{in}$  higher than  $C_{out}$  helps prevent reverse bias of the integrated body diode.

Use the same voltage rating criteria for the output capacitor as the input capacitor.

### Output Voltage Pull-down

The SC701 has an internal pull-down resistor. When the SC701 is disabled, the output pull-down resistor discharges the output capacitor through 1.5 k $\Omega$ . When the output voltage reaches a few hundred millivolts above ground, the discharge resistor is disconnected. SC701H does not have the discharge circuit.

### PCB Layout

Figure 1 shows the typical application circuit with PCB inductance on the circuit board. An important objective of the layout is to minimize the PCB inductance by reducing the length and increasing the width of the traces. The input and output capacitors need to be placed close to

the SC701/SC701H. The PCB inductance only effects the performance during the turn-on, turn-off and load transients. Figure 1 shows three current loops during the opening or closing of the switch. The magnitude of the voltage ringing at VIN or VOUT pin depends on the value of PCB inductance and placement of the capacitors. It is important to keep the voltage below the maximum rating of the SC701/SC701H.

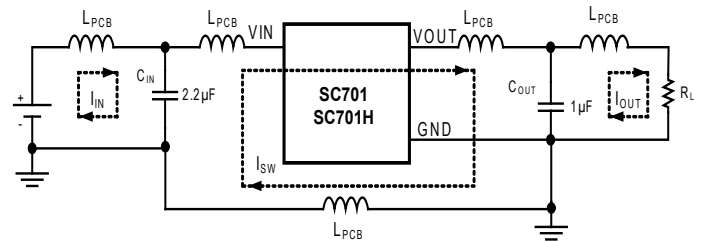
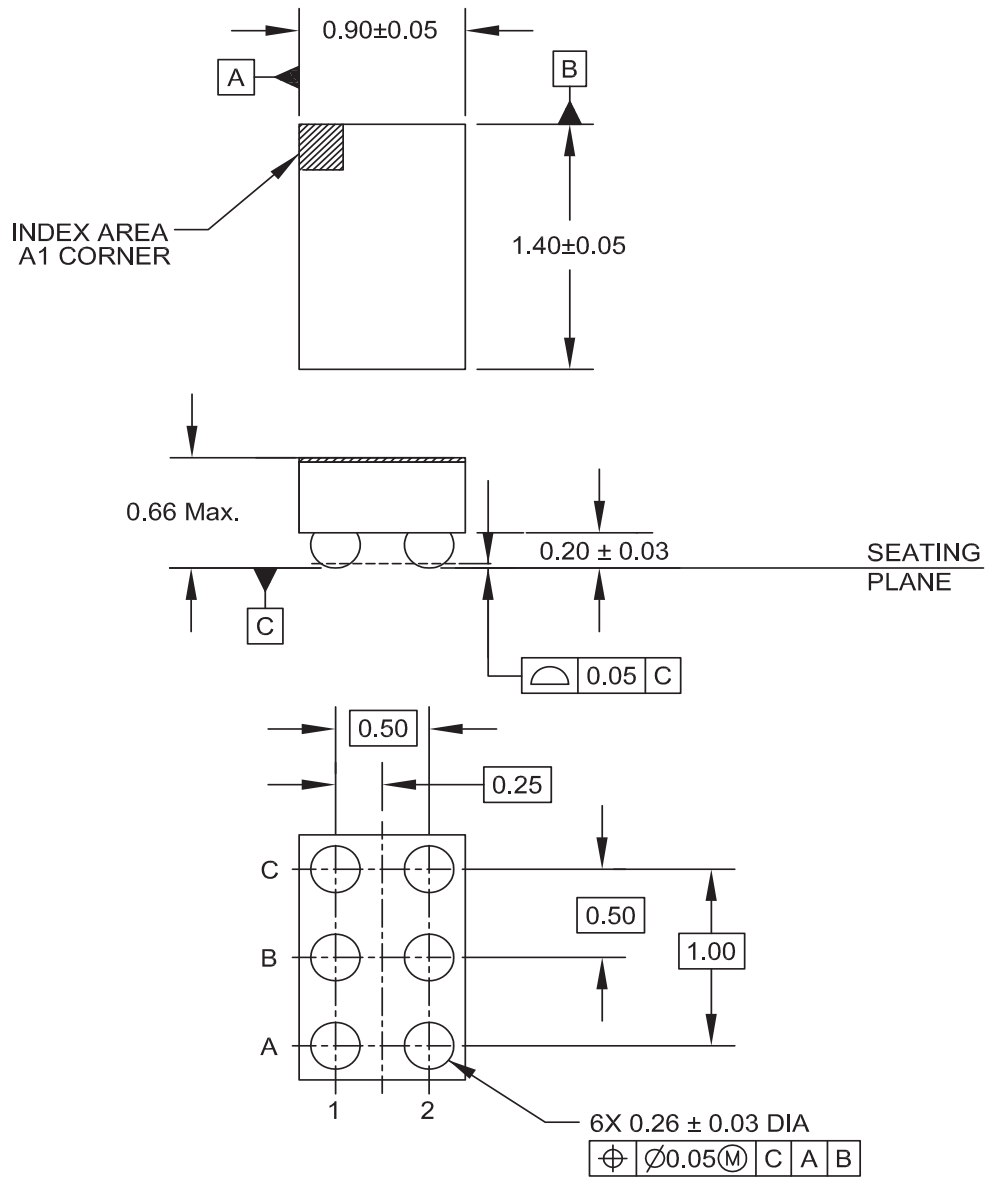

Figure 1 — Parasitic PCB Inductance Circuit

**Outline Drawing — CSP 0.9mm x 1.4mm, 6-Bump**



**NOTES:**

1. CONTROLLING DIMENSIONS ARE IN MILLIMETERS
2. DIMENSIONING AND TOLERATING PER ANSI Y14.5

Land Pattern Drawing — CSP 0.9mm x 1.4mm, 6-Bump

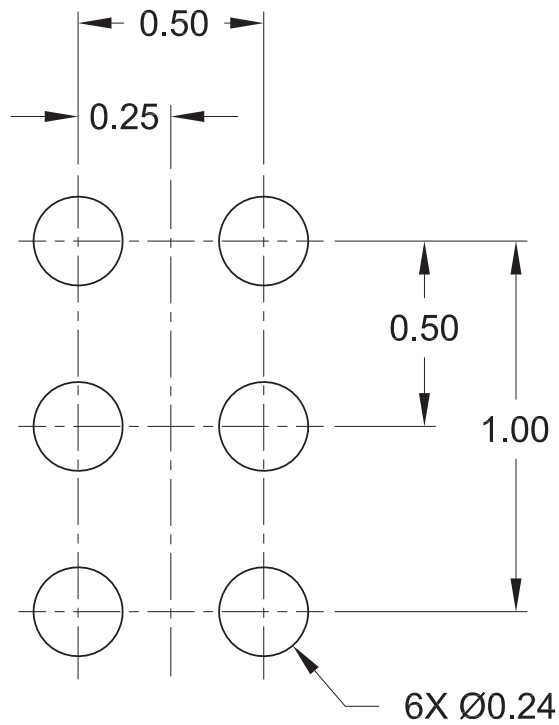

NOTES:

1. CONTROLLING DIMENSIONS ARE IN MILLIMETERS
2. THIS LAND PATTERN IS FOR REFERENCE PURPOSES ONLY.  
CONSULT YOUR MANUFACTURING GROUP TO ENSURE YOUR  
COMPANY'S MANUFACTURING GUIDELINES ARE MET.

© Semtech 2014

All rights reserved. Reproduction in whole or in part is prohibited without the prior written consent of the copyright owner. The information presented in this document does not form part of any quotation or contract, is believed to be accurate and reliable and may be changed without notice. No liability will be accepted by the publisher for any consequence of its use. Publication thereof does not convey nor imply any license under patent or other industrial or intellectual property rights. Semtech assumes no responsibility or liability whatsoever for any failure or unexpected operation resulting from misuse, neglect improper installation, repair or improper handling or unusual physical or electrical stress including, but not limited to, exposure to parameters beyond the specified maximum ratings or operation outside the specified range.

SEMTECH PRODUCTS ARE NOT DESIGNED, INTENDED, AUTHORIZED OR WARRANTED TO BE SUITABLE FOR USE IN LIFE-SUPPORT APPLICATIONS, DEVICES OR SYSTEMS OR OTHER CRITICAL APPLICATIONS. INCLUSION OF SEMTECH PRODUCTS IN SUCH APPLICATIONS IS UNDERSTOOD TO BE UNDERTAKEN SOLELY AT THE CUSTOMER'S OWN RISK. Should a customer purchase or use Semtech products for any such unauthorized application, the customer shall indemnify and hold Semtech and its officers, employees, subsidiaries, affiliates, and distributors harmless against all claims, costs damages and attorney fees which could arise.

Notice: All referenced brands, product names, service names and trademarks are the property of their respective owners.

## Contact Information

---

Taiwan	Tel: 886-2-2748-3380 Fax: 886-2-2748-3390	Switzerland	Tel: 41-32-729-4000 Fax: 41-32-729-4001
Korea	Tel: 82-2-527-4377 Fax: 82-2-527-4376	United Kingdom	Tel: 44-1794-527-600 Fax: 44-1794-527-601
Shanghai	Tel: 86-21-6391-0830 Fax: 86-21-6391-0831	France	Tel: 33-(0)169-28-22-00 Fax: 33-(0)169-28-12-98
Japan	Tel: 81-3-6408-0950 Fax: 81-3-6408-0951	Germany	Tel: 49-(0)8161-140-123 Fax: 49-(0)8161-140-124

## X-ON Electronics

Largest Supplier of Electrical and Electronic Components

*Click to view similar products for [Power Switch ICs - Power Distribution](#) category:*

*Click to view products by [Semtech](#) manufacturer:*

Other Similar products are found below :

[TCK111G,LF\(S\)](#) [FPF1018](#) [DS1222](#) [TCK2065G,LF](#) [SZNCP3712ASNT3G](#) [MIC2033-05BYMT-T5](#) [MIC2033-12AYMT-T5](#) [MIC2033-05BYM6-T5](#) [SLG5NT1437VTR](#) [SZNCP3712ASNT1G](#) [NCV330MUTBG](#) [DML1008LDS-7](#) [KTS1670EDA-TR](#) [KTS1640QGDV-TR](#) [KTS1641QGDV-TR](#) [NCV459MNWTBG](#) [FPF2260ATMX](#) [U6513A](#) [U6119S](#) [NCP45780IMN24RTWG](#) [MAX14919ATP+](#) [MC33882PEP](#) [TPS2021HDRQ1](#) [TPS2104DBVR](#) [MIC2098-1YMT-TR](#) [MIC94062YMT TR](#) [MP6231DN-LF](#) [MIC2075-2YM](#) [MIC2095-2YMT-TR](#) [MIC94068YML-TR](#) [SIP32461DB-T2-GE1](#) [NCP335FCT2G](#) [FPF2701MX](#) [TCK105G,LF\(S\)](#) [AP2151DSG-13](#) [MIC94094YC6-TR](#) [MIC94064YC6-TR](#) [MIC2505-1YM](#) [MIC94042YFL-TR](#) [MIC94041YFL-TR](#) [MIC2005-1.2YM6-TR](#) [TPS2032QDRQ1](#) [SIP32510DT-T1-GE3](#) [NCP333FCT2G](#) [NCP331SNT1G](#) [TPS2092DR](#) [TPS2063DR](#) [TPS2042P](#) [MIC2008YML-TR](#) [MIC2040-1YMM](#)