

PROTECTION PRODUCTS

Description

The SDxxC TVS diodes are designed to replace multi-layer varistors (MLVs) in portable applications such as cell phones, notebook computers, and PDA's. They offer superior electrical characteristics such as lower clamping voltage and no device degradation when compared to MLVs. The SDxxC series TVS diodes are designed to protect sensitive semiconductor components from damage or upset due to electrostatic discharge (ESD) and other voltage induced transient events.

The SDxxC is in a SOD-323 package and will protect one bidirectional line. They are available with working voltages of 5 - 24 volts. These devices will fit on the same PCB pad area as an 0805 MLV device. They give the designer the flexibility to protect one line in applications where arrays are not practical. Additionally, it may be "sprinkled" around the board in applications where board space is at a premium.

They may may be used to meet the ESD immunity requirements of IEC 61000-4-2, Level 4 ($\pm 15\text{kV}$ air, $\pm 8\text{kV}$ contact discharge).

Features

- ◆ 350 Watts peak pulse power ($t_p = 8/20\mu\text{s}$)
- ◆ Transient protection for data lines to
IEC 61000-4-2 (ESD) $\pm 15\text{kV}$ (air), $\pm 8\text{kV}$ (contact)
IEC 61000-4-4 (EFT) 40A (5/50ns)
IEC 61000-4-5 (Lightning) 24A (8/20 μs)
- ◆ Small package for use in portable electronics
- ◆ Suitable replacement for MLV's in ESD protection applications
- ◆ Protects one I/O or power line
- ◆ Low clamping voltage
- ◆ Working voltages: 5V, 12V, 15V, 24V
- ◆ Low leakage current
- ◆ Solid-state silicon avalanche technology

Mechanical Characteristics

- ◆ EIAJ SOD-323 package
- ◆ Molding compound flammability rating: UL 94V-0
- ◆ Marking : Marking code
- ◆ Packaging : Tape and Reel per EIA 481

Applications

- ◆ Cell Phone Handsets and Accessories
- ◆ Microprocessor based equipment
- ◆ Personal Digital Assistants (PDA's)
- ◆ Notebooks, Desktops, and Servers
- ◆ Portable Instrumentation
- ◆ Pagers
- ◆ Peripherals

Schematic & PIN Configuration

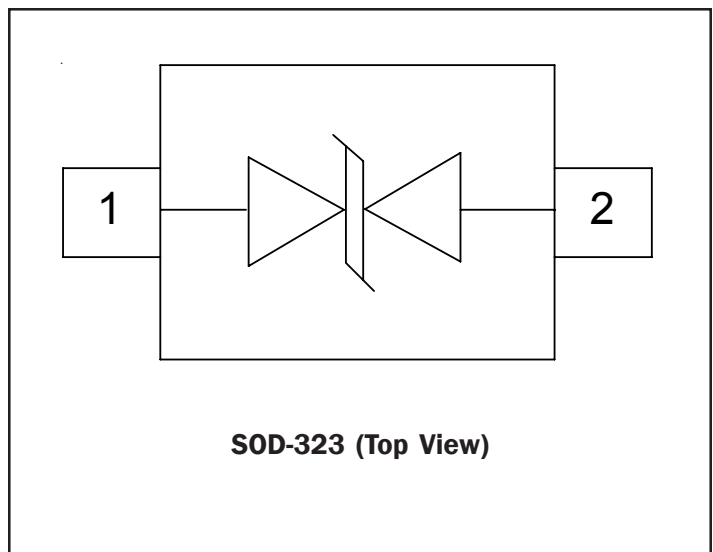

PROTECTION PRODUCTS

Absolute Maximum Rating

Rating	Symbol	Value	Units
Peak Pulse Power ($t_p = 8/20\mu s$)	P_{pk}	350	Watts
ESD Voltage (HBM Waveform per IEC 61000-4-2)	V_{ESD}	30	kV
Lead Soldering Temperature	T_L	260 (10 sec.)	$^{\circ}C$
Operating Temperature	T_J	-55 to +125	$^{\circ}C$
Storage Temperature	T_{STG}	-55 to +150	$^{\circ}C$

Electrical Characteristics

SD05C TVS

Parameter	Symbol	Conditions	Minimum	Typical	Maximum	Units
Reverse Stand-Off Voltage	V_{RWM}				5	V
Reverse Breakdown Voltage	V_{BR}	$I_t = 1mA$	6			V
Reverse Leakage Current	I_R	$V_{RWM} = 5V, T=25^{\circ}C$			10	μA
Clamping Voltage	V_C	$I_{PP} = 5A, t_p = 8/20\mu s$			9.8	V
Clamping Voltage	V_C	$I_{PP} = 24A, t_p = 8/20\mu s$			14.5	V
Peak Pulse Current	I_{PP}	$t_p = 8/20\mu s$			24	A
Junction Capacitance	C_J	$V_R = 0V, f = 1MHz$			200	pF

SD12C TVS

Parameter	Symbol	Conditions	Minimum	Typical	Maximum	Units
Reverse Stand-Off Voltage	V_{RWM}				12	V
Reverse Breakdown Voltage	V_{BR}	$I_t = 1mA$	13.3			V
Reverse Leakage Current	I_R	$V_{RWM} = 12V, T=25^{\circ}C$			1	μA
Clamping Voltage	V_C	$I_{PP} = 5A, t_p = 8/20\mu s$			19	V
Clamping Voltage	V_C	$I_{PP} = 15A, t_p = 8/20\mu s$			24	V
Peak Pulse Current	I_{PP}	$t_p = 8/20\mu s$			15	A
Junction Capacitance	C_J	$V_R = 0V, f = 1MHz$			100	pF

PROTECTION PRODUCTS
Electrical Characteristics (Continued)

SD15C TVS						
Parameter	Symbol	Conditions	Minimum	Typical	Maximum	Units
Reverse Stand-Off Voltage	V_{RWM}				15	V
Reverse Breakdown Voltage	V_{BR}	$I_t = 1mA$	16.7			V
Reverse Leakage Current	I_R	$V_{RWM} = 15V, T=25^{\circ}C$			1	μA
Clamping Voltage	V_C	$I_{PP} = 5A, t_p = 8/20\mu s$			24	V
Clamping Voltage	V_C	$I_{PP} = 12A, t_p = 8/20\mu s$			29	V
Peak Pulse Current	I_{PP}	$t_p = 8/20\mu s$			12	A
Junction Capacitance	C_J	$V_R = 0V, f = 1MHz$			75	pF

SD24C TVS						
Parameter	Symbol	Conditions	Minimum	Typical	Maximum	Units
Reverse Stand-Off Voltage	V_{RWM}				24	V
Reverse Breakdown Voltage	V_{BR}	$I_t = 1mA$	26.7			V
Reverse Leakage Current	I_R	$V_{RWM} = 24V, T=25^{\circ}C$			1	μA
Clamping Voltage	V_C	$I_{PP} = 5A, t_p = 8/20\mu s$			40	V
Clamping Voltage	V_C	$I_{PP} = 8A, t_p = 8/20\mu s$			44	V
Peak Pulse Current	I_{PP}	$t_p = 8/20\mu s$			8	A
Junction Capacitance	C_J	$V_R = 0V, f = 1MHz$			50	pF

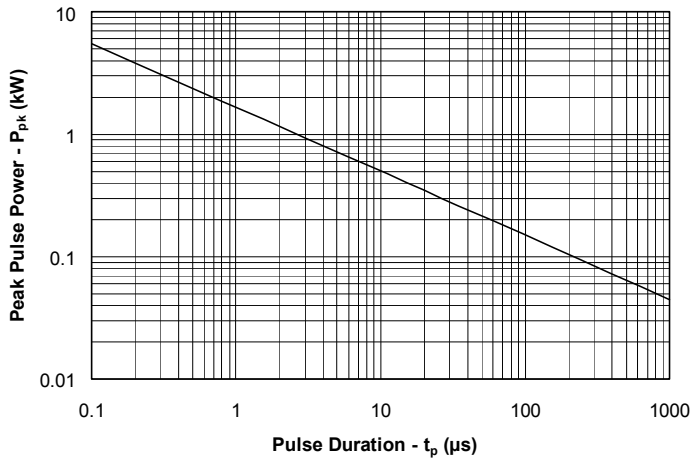
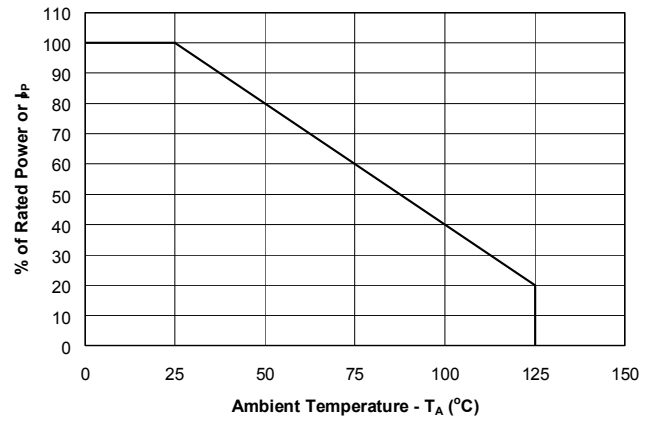
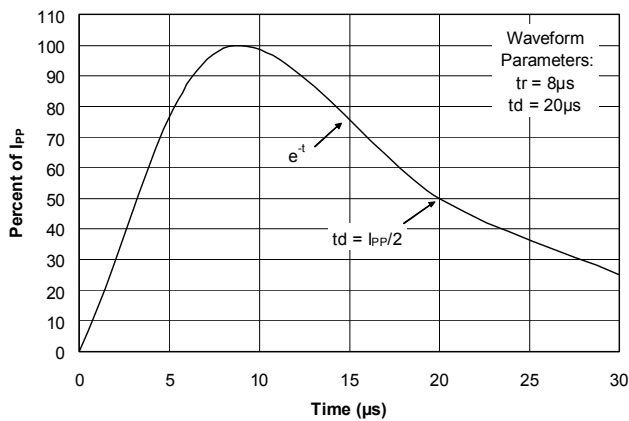
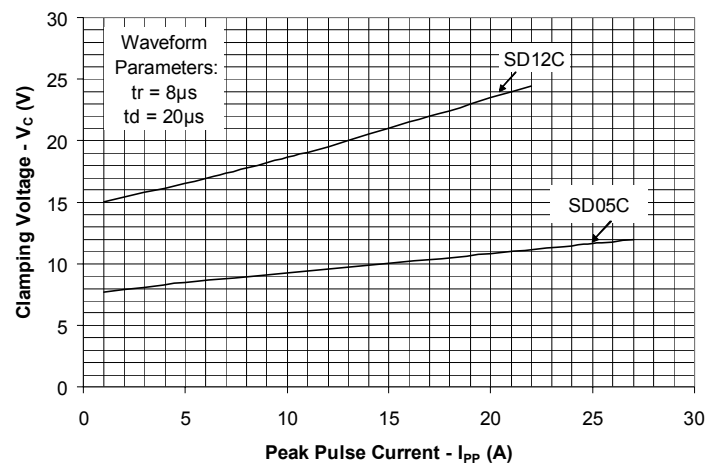
PROTECTION PRODUCTS
Typical Characteristics
Non-Repetitive Peak Pulse Power vs. Pulse Time

Power Derating Curve

Pulse Waveform

Clamping Voltage vs. Peak Pulse Current

PROTECTION PRODUCTS

Applications Information

Device Connection Options

The SDxxC TVS diodes are designed to protect one data, I/O, or power supply line. The device is designed to replace multi-layer varistors (MLVs) in portable applications. It is easily implemented on existing 0805 MLV pads and is only slightly larger than 0603 MLV pads. The device is bidirectional and may be used on lines where the signal polarity is above and below ground. The device is symmetrical, so there is no cathode band.

Circuit Board Layout Recommendations for Suppression of ESD.

Good circuit board layout is critical for the suppression of fast rise-time transients such as ESD. The following guidelines are recommended (Refer to application note SI99-01 for more detailed information):

- Place the TVS near the input terminals or connectors to restrict transient coupling.
- Minimize the path length between the TVS and the protected line.
- The ESD transient return path to ground should be kept as short as possible.
- Place a TVS and decoupling capacitor between power and ground of components that may be vulnerable to electrostatic discharges to the ground plane.
- Minimize all conductive loops including power and ground loops.
- Use multilayer boards when possible.
- Minimize interconnecting line lengths.
- Never run critical signals near board edges.
- Fill unused portions of the PCB with ground plane.

Matte Tin Lead Finish

Matte tin has become the industry standard lead-free replacement for SnPb lead finishes. A matte tin finish is composed of 100% tin solder with large grains. Since the solder volume on the leads is small compared to the solder paste volume that is placed on the land pattern of the PCB, the reflow profile will be determined by the requirements of the solder paste. Therefore, these devices are compatible with both lead-free and SnPb assembly techniques. In addition, unlike other lead-free compositions, matte tin does not have any added alloys that can cause degradation of the solder joint.

Device Schematic and Pin Configuration

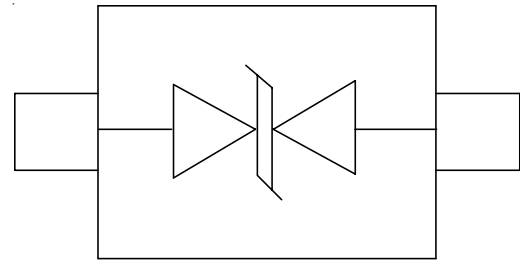

Size Comparison to 0805 MLV

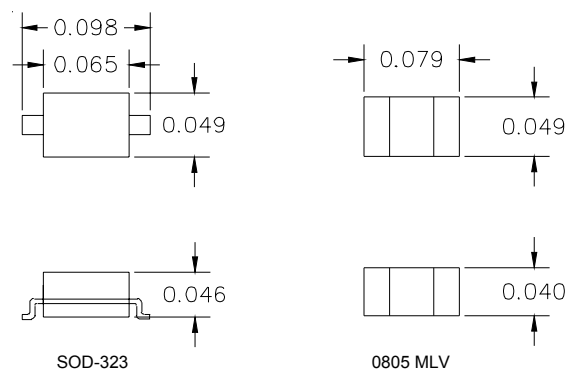

Note: Nominal dimensions in inches

Component Placement Comparison

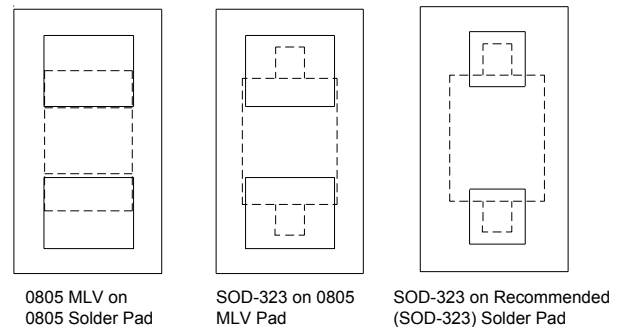

0805 MLV on 0805 Solder Pad

SOD-323 on 0805 MLV Pad

SOD-323 on Recommended (SOD-323) Solder Pad

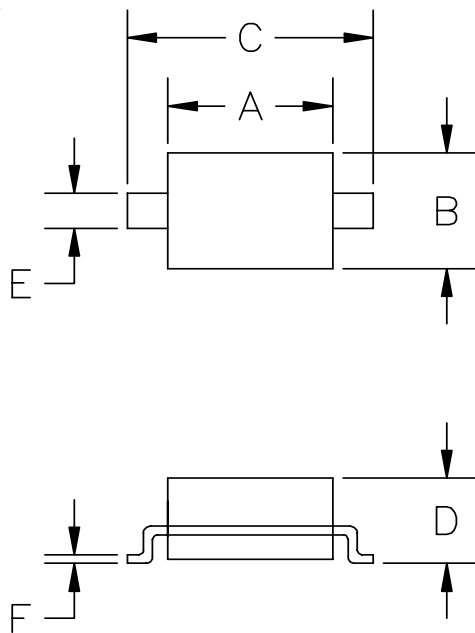
PROTECTION PRODUCTS
Outline Drawing - SOD-323

DIM ^N	INCHES		MM ¹		NOTE
	MIN	MAX	MIN	MAX	
A	.060	.071	1.5	1.8	—
B	.045	.054	1.2	1.4	—
C	.090	.107	2.3	2.7	—
D	—	.043	—	1.1	—
E	.012	.016	0.3	0.4	—
F	.004	.010	.10	.25	—
H	—	.004	—	.10	—

¹ CONTROLLING DIMENSION: MILLIMETERS

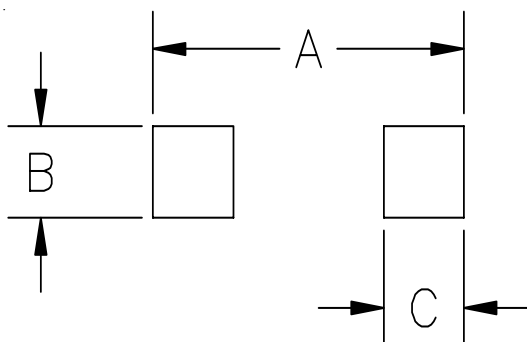
Land Pattern - SOD-323

DIM ^N	INCHES		MM ¹		NOTE
	MIN	MAX	MIN	MAX	
A	—	.120	—	3.05	—
B	—	.031	—	0.8	—
C	—	.031	—	0.8	—

¹ CONTROLLING DIMENSION: MILLIMETERS

PROTECTION PRODUCTS**Marking Codes**

Part Number	Marking Code
SD05C	5/9
SD12C	6/9
SD15C	7/L
SD24C	8/8

Ordering Information

Part Number	Lead Finish	Qty per Reel	Reel Size
SD05C.TC	SnPb	3,000	7"
SD12C.TC	SnPb	3,000	7"
SD15C.TC	SnPb	3,000	7"
SD24C.TC	SnPb	3,000	7"
SD05C.TCT	Pb free	3,000	7"
SD12C.TCT	Pb free	3,000	7"
SD15C.TCT	Pb free	3,000	7"
SD24C.TCT	Pb free	3,000	7"

Contact Information

Semtech Corporation
Protection Products Division
200 Flynn Rd., Camarillo, CA 93012
Phone: (805)498-2111 FAX (805)498-3804

X-ON Electronics

Largest Supplier of Electrical and Electronic Components

Click to view similar products for [ESD Suppressors / TVS Diodes](#) category:

Click to view products by [Semtech](#) manufacturer:

Other Similar products are found below :

[60KS200C](#) [D12V0H1U2WS-7](#) [D18V0L1B2LP-7B](#) [82356050220](#) [D5V0M5U6V-7](#) [NTE4902](#) [P4KE27CA](#) [P6KE11CA](#) [P6KE39CA-TP](#)
[P6KE8.2A](#) [SA110CA](#) [SA60CA](#) [SA64CA](#) [SMBJ12CATR](#) [SMBJ8.0A](#) [SMLJ30CA-TP](#) [ESD101-B1-02ELS E6327](#) [ESD112-B1-02EL E6327](#)
[ESD119B1W01005E6327XTSA1](#) [ESD5V0L1B02VH6327XTSA1](#) [ESD7451N2T5G](#) [19180-510](#) [CPDT-5V0USP-HF](#) [3.0SMCJ33CA-F](#)
[3.0SMCJ36A-F](#) [HSPC16701B02TP](#) [D3V3Q1B2DLP3-7](#) [D55V0M1B2WS-7](#) [DESD5V0U1BL-7B](#) [DRTR5V0U4SL-7](#) [SCM1293A-04SO](#)
[ESD200-B1-CSP0201 E6327](#) [ESD203-B1-02EL E6327](#) [SM12-7](#) [SMF8.0A-TP](#) [SMLJ45CA-TP](#) [CEN955 W/DATA](#) [82350120560](#)
[82356240030](#) [VESD12A1A-HD1-GS08](#) [CPDUR5V0R-HF](#) [CPDUR24V-HF](#) [CPDQC5V0U-HF](#) [CPDQC5V0USP-HF](#) [CPDQC5V0-HF](#)
[D1213A-01LP4-7B](#) [D1213A-02WL-7](#) [ESDLIN1524BJ-HQ](#) [5KP100A](#) [5KP15A](#)