

### DESCRIPTION

The SX8724C is a data acquisition system based on Semtech's low power ZoomingADC™ technology. It directly connects most types of miniature sensors with a general purpose microcontroller.

With 3 differential inputs, it can adapt to multiple sensor systems. Its digital outputs are used to bias or reset the sensing elements.

### APPLICATIONS

- Industrial pressure sensing
- Industrial temperature sensing
- Industrial chemical sensing
- Barometer
- Compass

### FEATURES

- Up to 16-bit differential data acquisition
- Programmable gain: (1/12 to 1000)
- Sensor offset compensation up to 15 times full scale of input signal
- 3 differential or 6 single-ended signal inputs
- Programmable Resolution versus Speed versus Supply current
- Digital outputs to bias Sensors
- Internal or external voltage reference
- Internal time base
- Low-power (250 uA for 16b @ 250 S/s)
- Fast I2C interface with external address option, no clock stretching required

### ORDERING INFORMATION

DEVICE	PACKAGE	REEL QUANTITY
SX8724CWLTDT	MLPQ-W-16 4x4	1000

- Available in tape and reel only
- WEEE/RoHS compliant, Pb-Free and Halogen Free.

### FUNCTIONAL BLOC DIAGRAM

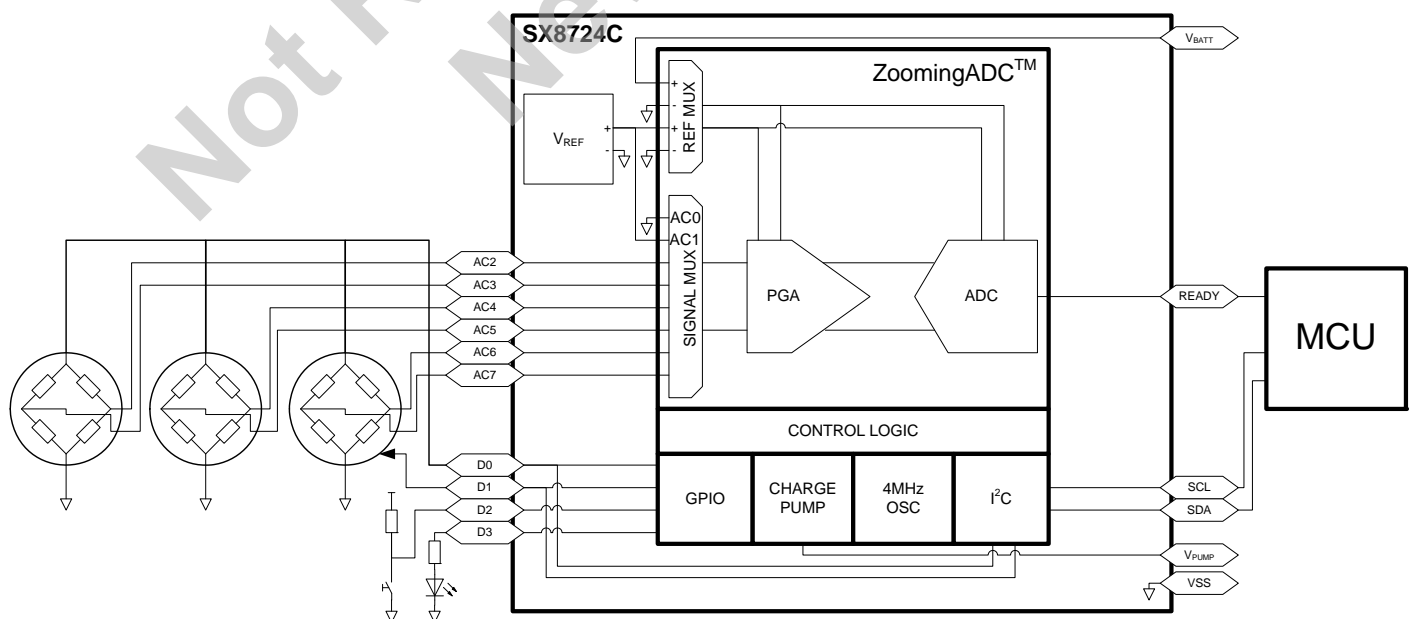

## TABLE OF CONTENT

Section	Page
ELECTRICAL SPECIFICATIONS .....	4
1 Absolute Maximum Ratings .....	4
2 Operating Conditions .....	5
2.1 Timing Characteristics .....	9
2.1.1 POR Waveforms .....	9
2.1.2 I2C interface timings .....	10
2.1.3 I2C timing Waveforms .....	11
CIRCUIT DESCRIPTION .....	12
3 Pin Configuration .....	12
4 Marking Information .....	12
5 Pin Description .....	13
6 General Description .....	14
6.1 Bloc diagram .....	14
6.2 VREF .....	14
6.3 GPIO .....	14
6.3.1 Optional Operating Mode: External Vref .....	16
6.4 Charge Pump .....	17
6.5 RC Oscillator .....	17
6.5.1 Wake-up from sleep .....	17
7 ZoomingADC .....	18
7.1 Overview .....	18
7.1.1 Acquisition Chain .....	18
7.1.2 Programmable Gain Amplifiers .....	19
7.1.3 PGA & ADC Enabling .....	20
7.2 ZoomingADC Registers .....	20
7.3 Input Multiplexers (AMUX and VMUX) .....	21
7.4 First Stage Programmable Gain Amplifier (PGA1) .....	22
7.5 Second Stage Programmable Gain Amplifier (PGA2) .....	23
7.6 Third Stage Programmable Gain Amplifier (PGA3) .....	23
7.6.1 PGA Ranges .....	25
7.7 Analog-to-Digital Converter (ADC) .....	28
7.7.1 Conversion Sequence .....	28
7.7.2 Over-Sampling Frequency (fs) .....	29
7.7.3 Over-Sampling Ratio (OSR) .....	29
7.7.4 Number of Elementary Conversions (Nelconv) .....	29
7.7.5 Resolution .....	30
7.7.6 Conversion Time & Throughput .....	31
7.7.7 Continuous-Time vs. On-Request Conversion .....	32
7.7.8 Output Code Format .....	33
7.7.9 Power Saving Modes .....	35
8 Application hints .....	36
8.1 Power Reduction .....	36
8.2 Gain Configuration Flow .....	37
9 I2C Interface .....	38
9.1 General Features .....	38
9.2 Other Slave Address Options .....	38

## TABLE OF CONTENT

Section	Page
9.2.1 Address Set Externally .....	39
9.3 I2C General Call Reset .....	39
9.4 I2C Register Access .....	40
9.4.1 Writing a Register .....	40
9.4.2 Reading in a Register .....	40
9.4.3 Writing in Several Consecutive Registers .....	40
9.4.4 Reading from Several Consecutive Registers .....	41
10 Register Memory Map and Description .....	42
10.1 Register Map .....	42
10.2 Registers Descriptions .....	42
10.2.1 RC Register .....	43
10.2.2 GPIO Registers .....	43
10.2.3 ZADC Registers .....	44
10.2.4 Mode Registers .....	46
11 Typical Performances .....	47
11.1 Input impedance .....	47
11.1.1 Switched Capacitor Principle .....	48
11.2 Frequency Response .....	49
11.3 Linearity .....	50
11.3.1 Integral Non-Linearity .....	50
11.3.2 Differential Non-Linearity .....	54
11.4 Noise .....	54
11.5 Gain Error and Offset Error .....	57
11.6 Power Consumption .....	58
 FAMILY OVERVIEW .....	 61
12 Comparizon table .....	61
13 Comparizon by package pinout .....	62
 MECHANICAL .....	 63
14 PCB Layout Considerations .....	63
15 How to Evaluate .....	63
16 Package Outline Drawing: MLPQ-W16-4x4-EP1 .....	64
17 Land Pattern Drawing: 4x4MLPQ-W16-EP1 .....	65
18 Tape and Reel Specification .....	66

## ELECTRICAL SPECIFICATIONS

### 1 Absolute Maximum Ratings

**Note** The Absolute Maximum Ratings, in table below, are stress ratings only. Functional operation of the device at conditions other than those indicated in the Operating Conditions sections of this specification is not implied. Exposure to the absolute maximum ratings, where different to the operating conditions, for an extended period may reduce the reliability or useful lifetime of the product.

**Table 1. Absolute Maximum Ratings**

Parameter	Symbol	Condition	Min	Max	Units
Power supply	VBATT		V <sub>SS</sub> - 0.3	6.5	V
Storage temperature	TSTORE		-55	150	°C
Temperature under bias	TBIAS		-40	140	°C
Input voltage	VINABS	All inputs	V <sub>SS</sub> - 300	VBATT + 300	mV
Peak reflow temperature	TPKG			260	°C
ESD conditions	ESDHBM	Human Body Model ESD	2000		V
Latchup			100		mA

## 2 Operating Conditions

Unless otherwise specified:  $V_{REF,ADC} = V_{BATT}$ ,  $V_{IN} = 0V$ , Over-sampling frequency  $f_s = 250$  kHz,  $PGA3$  on with  $Gain = 1$ ,  $PGA1$  &  $PGA2$  off, offsets  $GDOFF2 = GDOFF3 = 0$ . Power operation: normal ( $I_{bAmpAdc}[1:0] = I_{bAmpPga}[1:0] = '01'$ ).

For resolution  $n = 12$  bits:  $OSR = 32$  and  $NELCONV = 4$ .

For resolution  $n = 16$  bits:  $OSR = 256$  and  $NELCONV = 2$ .

Bandgap chopped at  $NELCONV$  rate. If  $V_{BATT} < 4.2V$ , Charge Pump is forced on. If  $V_{BATT} > 4.2V$ , Charge Pump is forced off.

**Table 2. Operating conditions limits**

Parameter	Symbol	Comment/Condition	Min	Typ	Max	Unit
Power supply	$V_{BATT}$		2.4		5.5	V
Operating temperature	TOP		-40		125	°C

**Table 3. Electrical Characteristics**

Parameter	Symbol	Comment/Condition	Min	Typ	Max	Unit
<b>CURRENT CONSUMPTION<sup>1</sup></b>						
Active current, 5.5V	IOP55	16 b @ 250 Sample/s ADC, $f_s = 125$ kHz		250	350	μA
		16 b @ 1kSample/s PGA3 + ADC, $f_s = 500$ kHz		700	900	
		16 b + gain 1000 @ 1kSample/s PGA3,2,1 + ADC, $f_s = 500$ kHz		1000	1350	
Active current, 3.3V	IOP33	16 b @ 250 Sample/s ADC, $f_s = 125$ kHz		150		μA
		16 b @ 1 kSample/s PGA3 + ADC, $f_s = 500$ kHz		300		
		16 b + gain 1000 @ 1kSample/s PGA3,2,1 + ADC, $f_s = 500$ kHz		850		
Sleep current	ISLEEP	@25°C		75		nA
		up to 85°C		100		
		@125°C		150	200	
<b>TIME BASE</b>						
Max ADC Over-Sampling frequency	$f_{Smax}$	@25°C	425	500	575	kHz
ADC Over-Sampling frequency drift	$f_{ST}$			0.15		% / °C
<b>DIGITAL I/O</b>						
Input logic high	$V_{IH}$		0.7			$V_{BATT}$
Input logic low	$V_{IL}$				0.3	$V_{BATT}$
Output logic high	$V_{OH}$	$I_{OH} < 4$ mA			$V_{BATT}-0.4$	V
Output logic low	$V_{OL}$	$I_{OL} < 4$ mA	0.4			V
<b>SCL and SDA I/O</b>						
Input logic high	$V_{IH}$		0.7			$V_{BATT}$

**Table 3. Electrical Characteristics**

Parameter	Symbol	Comment/Condition	Min	Typ	Max	Unit
Input logic low	VIL				0.25	VBATT
<b>Leakages currents</b>						
Input leakage current	I <sub>LeakIn</sub>	Digital input mode, no pull-up or pull-down	-100		100	nA
<b>VREF: Internal Bandgap Reference</b>						
Absolute output voltage	V <sub>BG</sub>	VBATT > 3V	1.19	1.22	1.25	V
Variation over Temperature	V <sub>BGT</sub>	VBATT > 3V, over Temperature	-1.5		+1.5	%
Total Output Noise	V <sub>BGN</sub>	VBATT > 3V			1	mVrms

- The device can be operated in either active or sleep states. The Sleep state is complete shutdown, but the active state can have a variety of different current consumptions depending on the settings. Some examples are given here: The Sleep state is the default state after power-on-reset. The chip can then be placed into an active state after a valid I2C communication is received.

**Table 4. ZoomingADC Specifications**

Parameter	Symbol	Condition	Min	Typ	Max	Unit
<b>ANALOG INPUT CHARACTERISTICS</b>						
Differential Input Voltage Range V <sub>IN</sub> = V <sub>INP</sub> -V <sub>INN</sub>		Gain=1, OSR=32, V <sub>REF</sub> =5V. <b>Note 1</b>	-2.42		+2.42	V
		Gain=100, OSR=32, V <sub>REF</sub> =5V	-24.2		+24.2	mV
		Gain=1000, OSR=32, V <sub>REF</sub> =5V	-2.42		+2.42	mV
<b>PROGRAMMABLE GAIN AMPLIFIER</b>						
Total PGA Gain	GD <sub>TOT</sub>	<b>Note 1</b>	1/12		1000	V/V
PGA1 Gain	GD <sub>1</sub>	(see <b>Table 11, page 22</b> )	1		10	V/V
PGA2 Gain	GD <sub>2</sub>	(see <b>Table 12, page 23</b> )	1		10	V/V
PGA3 Gain	GD <sub>3</sub>	Step = 1/12 V/V (see <b>Table 13, page 23</b> )	1/12		127/12	V/V
Gain Settings Precision (each stage)		Gain ≥ 1	-3	±0.5	+3	%
Gain Temperature Dependence				±5		ppm / °C
PGA2 Offset	GD <sub>OFF2</sub>	Step = 0.2 V/V (see <b>Table 12, page 23</b> )	-1		+1	V/V
PGA3 Offset	GD <sub>OFF3</sub>	Step = 1/12 V/V (see <b>Table 13, page 23</b> )	-63/12		+63/12	V/V
Offset Settings Precision (PGA2 or PGA3)		<b>Note 2</b>	-3	±0.5	+3	%
Offset Temperature Dependence				±5		ppm / °C
Input Impedance on PGA1 (see <b>section 11.1, page 47</b> )		Gain = 1. <b>Note 3</b>	1200	1350		kΩ
		Gain = 10. <b>Note 3</b>	250	300		kΩ
Input Impedance on PGA2,3		Gain = 1. <b>Note 3</b>	150	200		kΩ
Output RMS Noise per over-sample		PGA1. <b>Note 4</b>		205		μV
		PGA2. <b>Note 4</b>		340		μV
		PGA3. <b>Note 4</b>		365		μV

**Table 4. ZoomingADC Specifications**

Parameter	Symbol	Condition	Min	Typ	Max	Unit
<b>ADC STATIC PERFORMANCES</b>						
Resolution (No Missing Codes)	n	<b>Note 5</b> <b>Note 6</b>	6		16	Bits
Gain Error		<b>Note 7</b>		±0.15		%
Offset Error		n = 16 bits. <b>Note 8</b>		±1		LSB
Integral Non-Linearity	INL	resolution n = 12 bits. <b>Note 9</b>		±0.6		LSB
		resolution n = 16 bits. <b>Note 9</b>		±1.5		LSB
Differential Non-Linearity	DNL	resolution n = 12 bits. <b>Note 10</b>		±0.5		LSB
		resolution n = 16 bits. <b>Note 10</b>		±0.5		LSB
Power Supply Rejection Ratio DC	PSRR	V <sub>BATT</sub> = 5V +/- 0.3V. <b>Note 11</b>		78		dB
		V <sub>BATT</sub> = 3V +/- 0.3V. <b>Note 11</b>		72		dB
<b>ADC DYNAMIC PERFORMANCES</b>						
Conversion Time	T <sub>CONV</sub>	n = 12 bits. <b>Note 12</b>		133		fs cycles
		n = 16 bits. <b>Note 12</b>		517		fs cycles
Throughput Rate (Continuous Mode)	1/T <sub>CONV</sub>	n = 12 bits, f <sub>s</sub> = 250 kHz		1.88		kSps
		n = 16 bits, f <sub>s</sub> = 250 kHz		0.483		kSps
PGA Stabilization Delay		<b>Note 13</b> (see <b>Table 12, page 23</b> )		OSR		fs cycles
<b>ZADC ANALOG QUIESCENT CURRENT</b>						
ADC Only Consumption	I <sub>Q</sub>	V <sub>BATT</sub> = 5.5V/3.3V		285/210		µA
PGA1 Consumption		V <sub>BATT</sub> = 5.5V/3.3V		104/80		µA
PGA2 Consumption		V <sub>BATT</sub> = 5.5V/3.3V		67/59		µA
PGA3 Consumption		V <sub>BATT</sub> = 5.5V/3.3V		98/91		µA
<b>ANALOG POWER DISSIPATION : All PGAs &amp; ADC Active</b>						
Normal Power Mode		V <sub>BATT</sub> = 5.5V/3.3V. <b>Note 14</b>		4.0/2.0		mW
3/4 Power Reduction Mode		V <sub>BATT</sub> = 5.5V/3.3V. <b>Note 15</b>		3.2/1.6		mW
1/2 Power Reduction Mode		V <sub>BATT</sub> = 5.5V/3.3V. <b>Note 16</b>		2.4/1.1		mW
1/4 Power Reduction Mode		V <sub>BATT</sub> = 5.5V/3.3V. <b>Note 17</b>		1.5/0.7		mW

- (1) Gain defined as overall PGA gain  $G_{TOT} = G_{D1} \times G_{D2} \times G_{D3}$ . Maximum input voltage is given by:  $V_{IN,MAX} = \pm(V_{REF} / 2) (OSR / OSR + 1)$ .
- (2) Offset due to tolerance on  $G_{Doff2}$  or  $G_{Doff3}$  setting. For small intrinsic offset, use only ADC and PGA1.
- (3) Measured with block connected to inputs through  $A_{mux}$  block. Normalized input sampling frequency for input impedance is  $f_s = 500$  kHz ( $f_s$  max, worst case). This figure must be multiplied by 2 for  $f_s = 250$  kHz, 4 for  $f_s = 125$  kHz. Input impedance is proportional to  $1/f_s$ .
- (4) Figure independent from gain and sampling frequency.  $f_s$ . The effective output noise is reduced by the over-sampling ratio
- (5) Resolution is given by  $n = 2 \log_2(OSR) + \log_2(NELCONV)$ .  $OSR$  can be set between 8 and 1024, in powers of 2.  $NELCONV$  can be set to 1, 2, 4 or 8.
- (6) If a ramp signal is applied to the input, all digital codes appear in the resulting ADC output data.
- (7) Gain error is defined as the amount of deviation between the ideal (theoretical) transfer function and the measured transfer function (with the offset error removed).
- (8) Offset error is defined as the output code error for a zero volt input (ideally, output code = 0). For 1 LSB offset,  $NELCONV$  must be at least 2.
- (9) INL defined as the deviation of the DC transfer curve of each individual code from the best-fit straight line. This specification holds over the full scale.
- (10) DNL is defined as the difference (in LSB) between the ideal (1 LSB) and measured code transitions for successive codes.
- (11) Values for Gain = 1. PSRR is defined as the amount of change in the ADC output value as the power supply voltage changes.

- (12) Conversion time is given by:  $T_{CONV} = (N_{ELCONV}(OSR + 1) + 1) / f_s$ . *OSR* can be set between 8 and 1024, in powers of 2. *NELCONV* can be set to 1, 2, 4 or 8.
- (13) PGAs are reset after each writing operation to registers **RegACCfg1-5**, corresponding to change of configuration or input switching. The ADC should be started only some delay after a change of PGA configuration through these registers. Delay between change of configuration of PGA or input channel switching and ADC start should be equivalent to *OSR* (between 8 and 1024) number of cycles. This is done by writing bit Start several cycles after PGA settings modification or channel switching. This delay does not apply to conversions made without the PGAs.
- (14) Nominal (maximum) bias currents in PGAs and ADC, i.e.  $IbAmpPga[1:0] = '11'$  and  $IbAmpAdc[1:0] = '11'$ .
- (15) Bias currents in PGAs and ADC set to 3/4 of nominal values, i.e.  $IbAmpPga[1:0] = '10'$ ,  $IbAmpAdc[1:0] = '10'$ .
- (16) Bias currents in PGAs and ADC set to 1/2 of nominal values, i.e.  $IbAmpPga[1:0] = '01'$ ,  $IbAmpAdc[1:0] = '01'$ .
- (17) Bias currents in PGAs and ADC set to 1/4 of nominal values, i.e.  $IbAmpPga[1:0] = '00'$ ,  $IbAmpAdc[1:0] = '00'$ .

Not Recommended for  
New Designs



## 2.1 Timing Characteristics

**Table 5. General timings**

Parameter	Symbol	Comment/Condition	Min	Typ	Max	Unit
<b>ADC INTERRUPT (READY) TIMING SPECIFICATIONS</b>						
READY pulse width	t <sub>IRQ</sub>	<b>Note 1</b>		1		1/fs
<b>STARTUP TIMES</b>						
Startup sequence time at POR	t <sub>START</sub>				800	μs
Time to enable RC from Sleep after an I2C command	t <sub>RCEN</sub>				450	μs

(1) The READY pulse indicates End of Conversion. This is a Positive pulse of duration equal to one cycle of the ADC sampling rate in “continuous mode”.

See also [Figure 17, page 33](#).

### 2.1.1 POR Waveforms

At device power-on or after a software reset

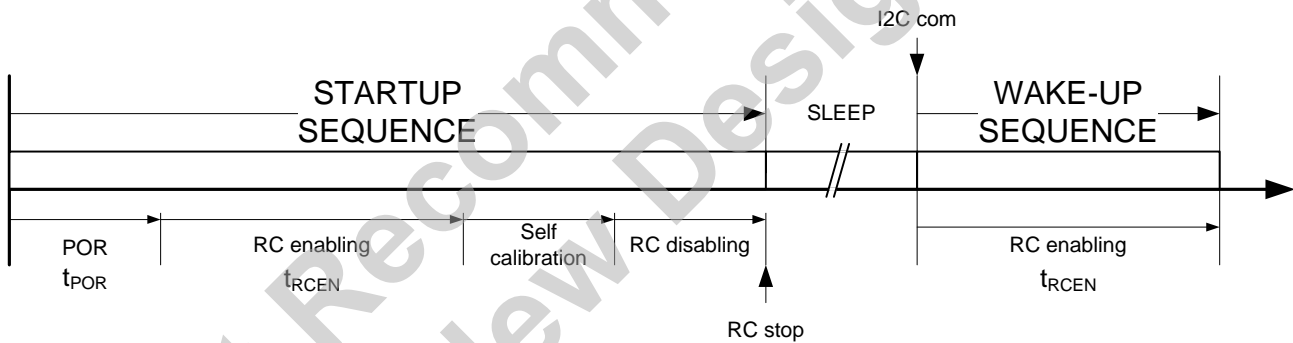

Figure 1. Power-On-Reset waveform

**2.1.2 I2C interface timings**
**Table 6. Digital interface**

Parameter	Symbol	STANDARD-MODE			FAST-MODE			Unit
		Min	Typ	Max	Min	Typ	Max	
<b>I2C TIMING SPECIFICATIONS Note 1</b>								
SCL clock frequency	f <sub>SCL</sub>	0		100	0		400	kHz
SCL timeout ( optional mode ) Note 2	t <sub>SCLTO</sub>	35			35			ms
SCL Low Pulsewidth	t <sub>L</sub>	4.7			1.3			μs
SCL High Pulsewidth	t <sub>H</sub>	4.0			0.6			μs
Start Condition Hold Time	t <sub>SCH</sub>	0.6			0.6			μs
Data Setup Time	t <sub>DS</sub>	250			100 Note 3			ns
Data Hold Time	t <sub>DH</sub>	0 Note 4		3.45	0		0.9	μs
Setup Time for Repeated Start	t <sub>RSU</sub>	4.7			0.6			μs
Stop Condition Setup Time	t <sub>PSU</sub>	4.0			0.6			μs
Bus Free Time between a STOP Condition and a START Condition	t <sub>BF</sub>	4.7			1.3			μs
Pulsewidth of Spike Suppressed	t <sub>SUP</sub>		100			100		ns
Capacitive load for each bus line	C <sub>B</sub>			400			400	pF
Noise margin at the LOW level for each connected device (including hysteresis)	V <sub>nL</sub>	0.1V <sub>BATT</sub>			0.1V <sub>BATT</sub>			V
Noise margin at the HIGH level for each connected device (including hysteresis)	V <sub>nH</sub>	0.2V <sub>BATT</sub>			0.2V <sub>BATT</sub>			V

- (1) All timings specifications are referred to V<sub>ILmin</sub> and V<sub>IHmax</sub> voltage levels defined for the SCL and SDA pins.
- (2) The digital interface is reset if the SCL is low more than t<sub>SCLTO</sub> duration. This is the default mode at startup. The timeout can be disabled by register setting.
- (3) A Fast-mode I2C-bus device can be used in a Standard-mode I2C-bus system.
- (4) The device internally provides a hold time of at least 300 ns for the SDA signal (referred to the V<sub>IHmin</sub> of the SCL signal) to bridge the undefined region of the falling edge of SCL.
- (5) C<sub>b</sub> = total capacitance of one bus line in pF. If mixed with Hs-mode devices, faster fall-times according to Table 6 are allowed.

**2.1.3 I2C timing Waveforms**

Figure 2. Definition of timing for F/S-mode on the I2C-bus.

## CIRCUIT DESCRIPTION

### 3 Pin Configuration

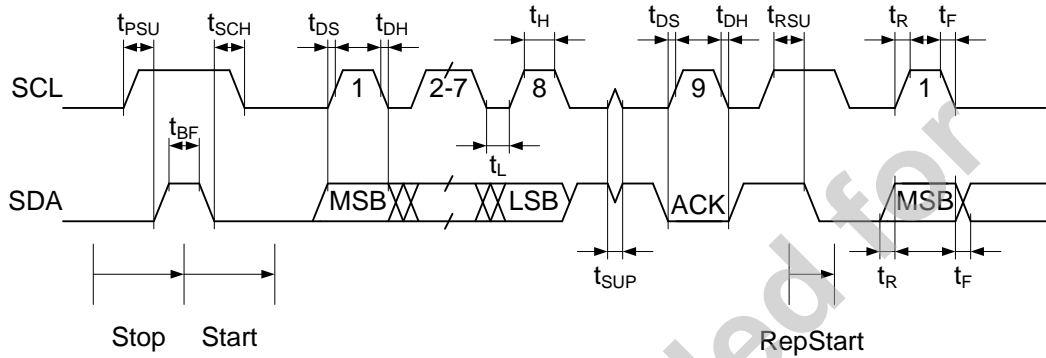
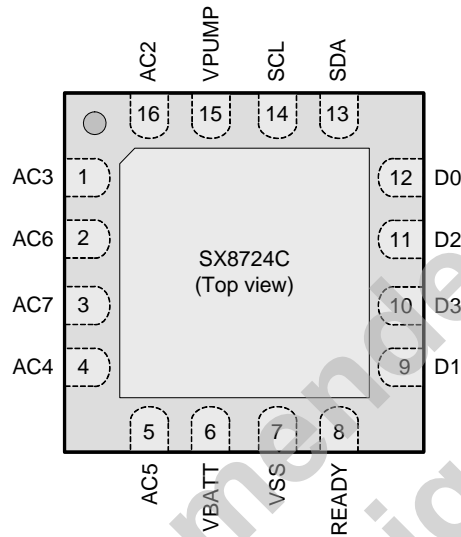

### 4 Marking Information



nnnnn = Part Number  
 yyww = Date Code<sup>1</sup>  
 xxxxx = Semtech Lot Number  
 xxxxx

1.Date codes and Lot numbers starting with the 'E' character are used for Engineering samples

## 5 Pin Description

**Note** The bottom pin is internally connected to VSS. It should also be connected to VSS on PCB to reduce noise and improve thermal behavior.

Pin	Name	Type	Function
1	AC3	Analog Input	Differential sensor input in conjunction with AC2
2	AC6	Analog Input	Differential sensor input in conjunction with AC7
3	AC7	Analog Input	Differential sensor input in conjunction with AC6
4	AC4	Analog Input	Differential sensor input in conjunction with AC5
5	AC5	Analog Input	Differential sensor input in conjunction with AC4
6	VBATT	Power Input	2.4V to 5.5V power supply
7	VSS	Power Input	Chip ground
8	READY	Digital Output	Conversion complete flag.
9	D1	Digital IO + analog input	Digital output sensor drive (VBATT or VSS)
			VREF input in optional operating mode
			I2C address bit 1. Msb address bits are fuse programmed.
10	D3	Digital IO	Digital output sensor drive (VBATT or VSS)
11	D2	Digital IO	Digital output sensor drive (VBATT or VSS)
12	D0	Digital IO + analog output	Digital output sensor drive (VBATT or VSS)
			VREF output in optional operating mode
			I2C address bit 0. MSB address bits are fuse programmed.
13	SDA	Digital IO	I2C data line
14	SCL	Digital IO	I2C clock line. Up to 400 kHz.
15	VPUMP	Power IO	Charge pump output. Raises analog switch supply above VBATT if VBATT supply is too low. Recommended range for capacitor is 1nF to 10 nF. Connect the capacitor to ground.
16	AC2	Analog Input	Differential sensor input in conjunction with AC3

## 6 General Description

The SX8724C is a complete low-power acquisition path with programmable gain, acquisition speed and resolution.

### 6.1 Bloc diagram

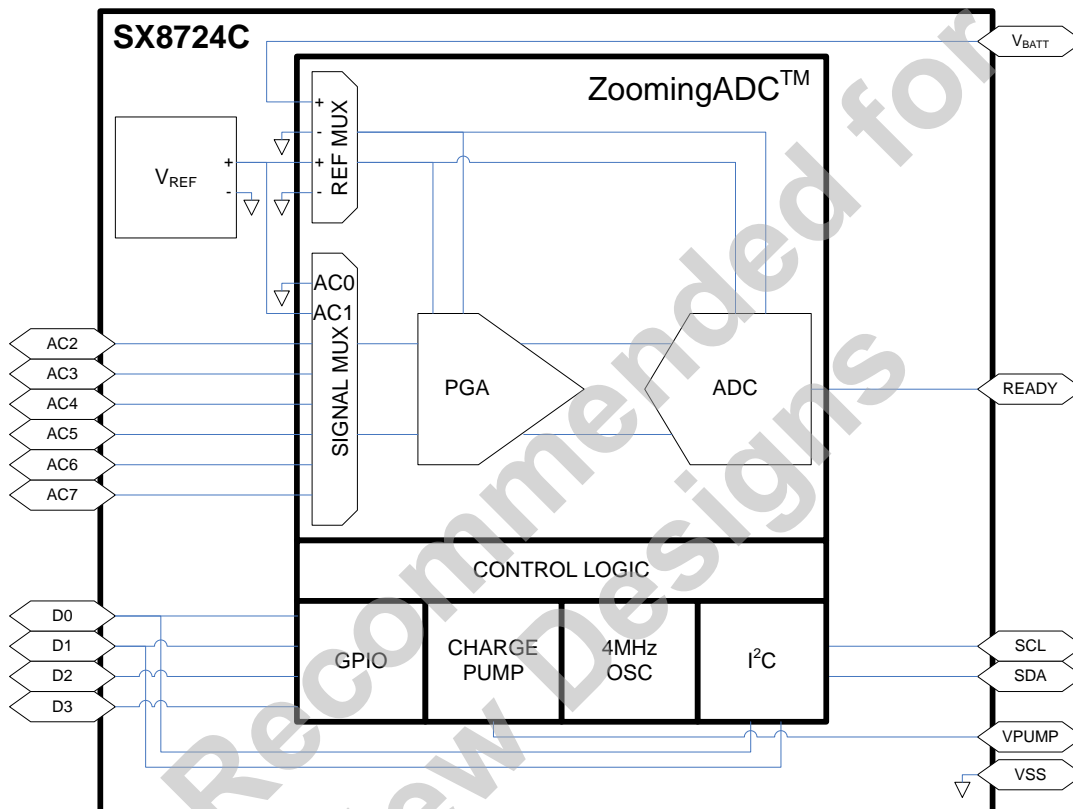

Figure 3. SX8724C bloc diagram

### 6.2 VREF

The internally generated  $V_{REF}$  is a trimmed bandgap reference with a nominal value of 1.22V that provides a stable voltage reference for the ZoomingADC.

This reference voltage is directly connected to one of the ZoomingADC reference multiplexer inputs.

The bandgap voltage stability is only guaranteed for  $V_{BATT}$  voltages of 3V and above. As  $V_{BATT}$  drops down to 2.4V, the bandgap voltage could reduce by up to 50mV.

The bandgap has relatively weak output drive so it is recommended that if the bandgap is required as a signal input then  $PGA1$  must be enabled with gain = 1.

### 6.3 GPIO

The  $GPIO$  block is a multipurpose 4 bit input/output port. In addition to digital behavior,  $D0$  and  $D1$  pins can be programmed as analog pins in order to be used as output (reference voltage monitoring) and input for an external

reference voltage (For further details see [Figure 6](#), [Figure 7](#), [Figure 8](#) and [Figure 9](#)). Each port terminal can be individually selected as digital input or output.

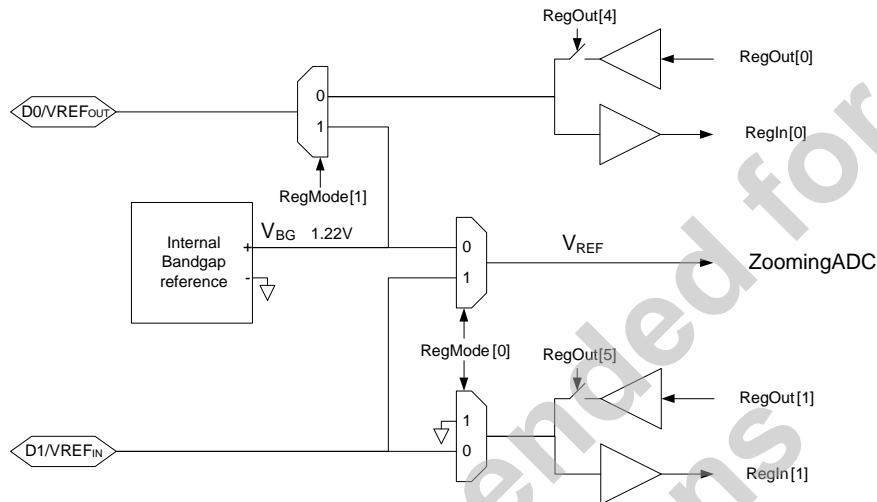

Figure 4. GPIO bloc diagram

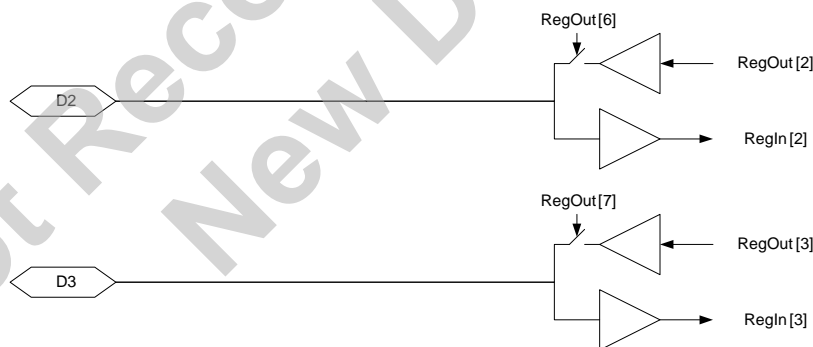

Figure 5. Digital IO bloc diagram

The direction of each bit within the *GPIO* block (input only or input/output) can be individually set using the bits of the **RegOut** (address 0x40) register. If  $D[x]Dir = 1$ , both the input and output buffer are active on the corresponding *GPIO* block pin. If  $D[x]Dir = 0$ , the corresponding *GPIO* block pin is an input only and the output buffer is in high impedance. After power on reset the *GPIO* block pins are in input/output mode ( $D[x]Dir$  are reset to 1).

The input values of *GPIO* block are available in **RegIn** (address 0x41) register (read only). Reading is always direct - there is no debounce function in the *GPIO* block. In case of possible noise on input signals, an external hardware filter has to be realized. The input buffer is also active when the *GPIO* block is defined as output and the effective value on the pin can be read back.

Data stored in the LSB bits of **RegOut** register are outputted at *GPIO* block if  $D[x]Dir = 1$ . The default values after power on reset is low (0).

The digital pins are able to deliver a driving current up to 8 mA.

When the bits *VrefD0Out* and *VrefD1In* in the **RegMode** (address 0x70) register are set to 1 the *D0* and *D1* pins digital behavior are automatically bypassed in order to either input or output the voltage reference signals.

### 6.3.1 Optional Operating Mode: External Vref

*D0* and *D1* are multi-functional pins with the following functions in different operating modes (see **RegMode** register for control settings):

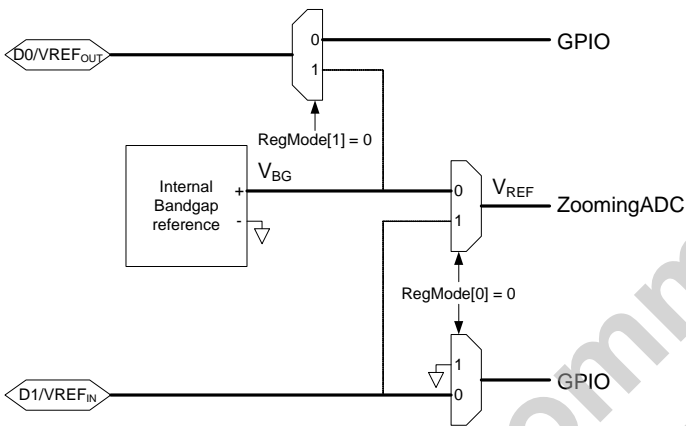

Figure 6. *D0* and *D1* are Digital Inputs / Outputs

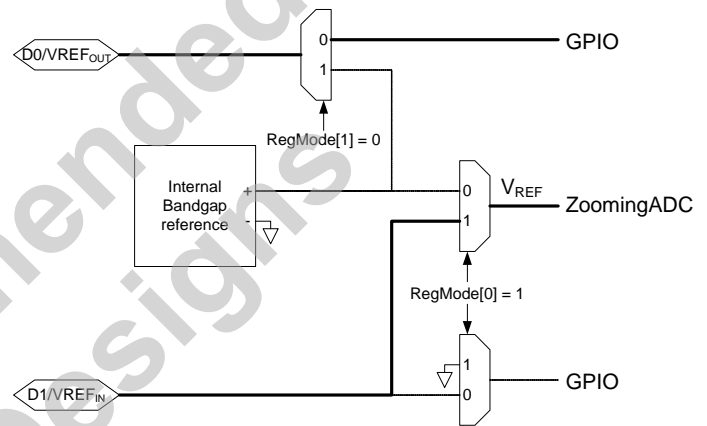

Figure 7. *D1* is Reference Voltage Input and *D0* is Digital Input / Output

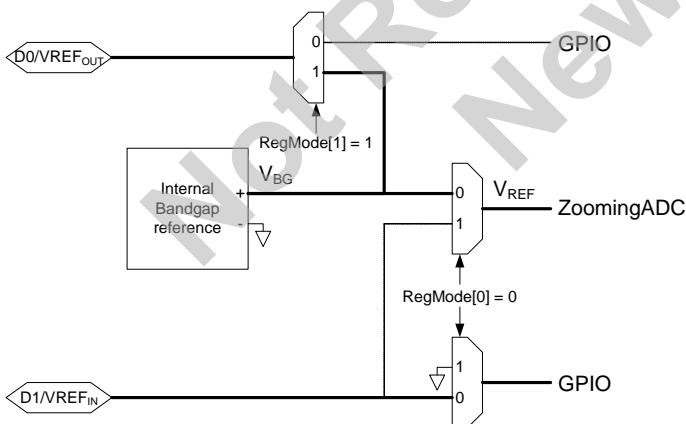

Figure 8. *D1* is Digital Input / Output and *D0* Reference Voltage Output

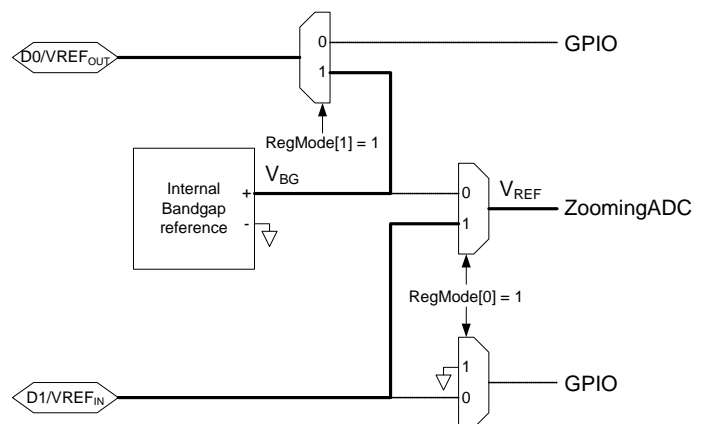

Figure 9. *D0* is Reference Voltage Output and *D1* is Reference Voltage Input

This allows external monitoring of the internal bandgap reference or the ability to use an external reference input for the ADC, or the option to filter the internal  $V_{REF}$  output before feeding back as  $V_{REF,ADC}$  input. The internally generated  $V_{REF}$  is a trimmed as ADC reference with a nominal value of 1.22V. When using an external  $V_{REF,ADC}$  input, it may have any value between 0V and  $V_{BATT}$ . Simply substitute the external value for 1.22 V in the ADC conversion calculations.



## 6.4 Charge Pump

This block generates a supply voltage able to power the analog switch drive levels on the chip higher than  $V_{BATT}$  if necessary.

If  $V_{BATT}$  voltage drops below 4.2V then the block should be activated. If  $V_{BATT}$  voltage is greater than 4.2V then  $V_{BATT}$  may be switched straight through to the  $VPUMP$  output. If the charge pump is not activated then  $VPUMP = V_{BATT}$ .

If control input bit  $MultForceOff = 1$  in **RegMode** (address 0x70) register then the charge pump is disabled and  $V_{BATT}$  is permanently connected to  $VPUMP$  output.

If control input bit  $MultForceOn = 1$  in **RegMode** register then the charge pump is permanently enabled. This overrides  $MultForceOff$  bit in **RegMode** register.

An external capacitor is required on  $VPUMP$  pin. This capacitor should be large enough to ensure that generated voltage is smooth enough to avoid affecting conversion accuracy but not so large that it gives an unacceptable settling time. A recommended value is around 2.2nF.

## 6.5 RC Oscillator

This block provides the master clock reference for the chip. It produces a clock at 4 MHz which is divided internally in order to generate the clock sources needed by the other blocks.

The oscillator technique is a low power relaxation design and it is designed to vary as little as possible over temperature and supply voltage.

This oscillator is trimmed at manufacture chip test.

The  $RC$  oscillator will start up after a chip reset to allow the trimming values to be read and calibration registers and I2C address set to their default fused values. Once this has been done, the oscillator will be shut down and the chip will enter a sleep state while waiting for an I2C communication.

The worst case duration from reset ( or POR ) to the sleep state is 800us.

### 6.5.1 Wake-up from sleep

When the device is in sleep state, the  $RC$  oscillator will start up after a communication. The start up sequence for the  $RC$  oscillator is 450us in worst case.

During this time, the internal blocs using the  $RC$  can not be used: no ADC conversion can be started.

## 7 ZoomingADC

### 7.1 Overview

The *ZoomingADC* is a complete and versatile low-power analog front-end interface typically intended for sensing applications. In the following text the *ZoomingADC* will be referred as ZADC.

The key features of the ZADC are:

- Programmable 6 to 16-bit dynamic range over-sampled ADC
- Flexible gain programming between 1/12 and 1000
- Flexible and large range offset compensation
- Differential or single-ended input
- 2-channel differential reference inputs
- Power saving modes

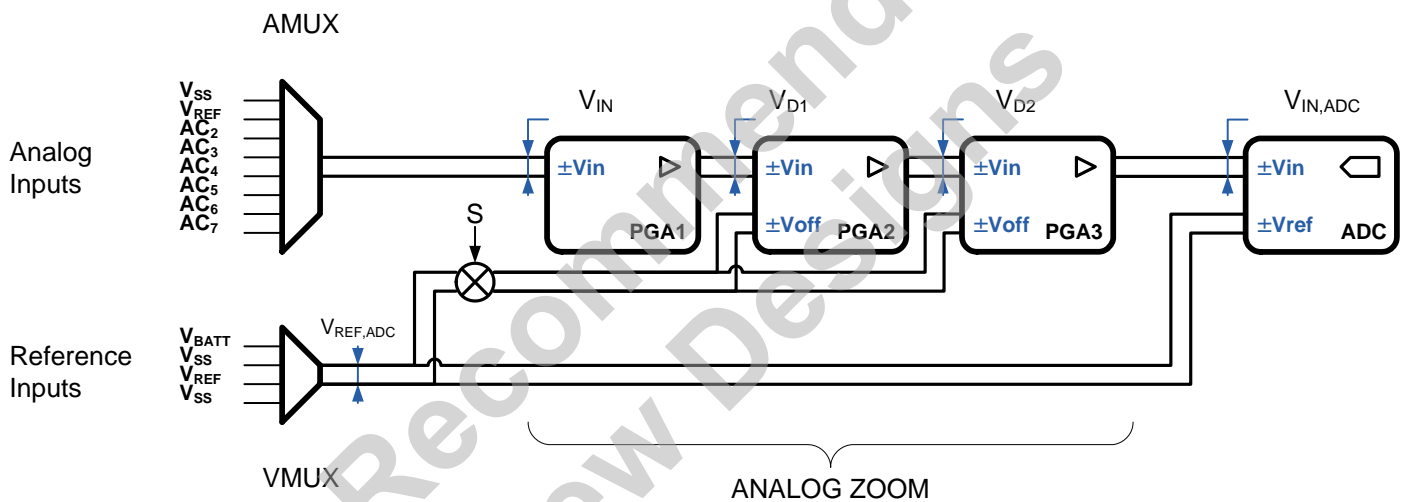

Figure 10. ZADC General Functional Block Diagram

The total acquisition chain consists of an input multiplexer, 3 programmable gain amplifier stages and an over sampled A/D converter. The reference voltage can be selected on two different channels. Two offset compensation amplifiers allow for a wide offset compensation range. The programmable gain and offset allow the application to zoom in on a small portion of the reference voltage defined input range.

#### 7.1.1 Acquisition Chain

Figure 10, page 18 shows the general block diagram of the acquisition chain (AC). A control block (not shown in Figure 10) manages all communications with the I2C peripheral. The clocking is derived from the internal 4 MHz Oscillator.

Analog inputs can be selected through an 8 input multiplexer, while reference input is selected between two differential channels. It should however be noted that only 7 acquisition channels (including the VREF) are available when configured as single ended since the input amplifier is always operating in differential mode with both positive and negative input selected through the multiplexer.

The core of the zooming section is made of three differential programmable amplifiers (*PGA*). After selection of an input and reference signals  $V_{IN}$  and  $V_{REF,ADC}$  combination, the input voltage is modulated and amplified through stages 1 to 3. Fine gain programming up to 1'000 V/V is possible. In addition, the last two stages provide programmable offset. Each amplifier can be bypassed if needed.

The output of the cascade of *PGA* is directly fed to the analog-to-digital converter (*ADC*), which converts the signal  $V_{IN,ADC}$  into digital.

Like most *ADCs* intended for instrumentation or sensing applications, the ZoomingADC™ is an over-sampled converter<sup>1</sup>. The *ADC* is a so-called incremental converter; with bipolar operation (the *ADC* accepts both positive and negative differential input voltages). In first approximation, the *ADC* output result relative to full-scale (*FS*) delivers the quantity:

$$\frac{OUT_{ADC}}{FS/2} \cong \frac{V_{IN,ADC}}{V_{REF}/2}$$

**Equation 1**

in two's complement (see [Equation 18](#) and [Equation 19](#), page 33 for details). The output code  $OUT_{ADC}$  is  $-FS/2$  to  $+FS/2$  for  $V_{IN,ADC} = -V_{REF,ADC}/2$  to  $+V_{REF,ADC}/2$  respectively. As will be shown,  $V_{IN,ADC}$  is related to input voltage  $V_{IN}$  by the relationship:

$$V_{IN,ADC} = GD_{TOT} \cdot V_{IN} - GD_{Off,TOT} \cdot S \cdot V_{REF} \quad [V]$$

**Equation 2**

where  $GD_{TOT}$  is the total *PGA* gain,  $GD_{Off,TOT}$  is the total magnitude of *PGA* offset and  $S$  is the sign of the offset (see [Table 9](#), page 21).

### 7.1.2 Programmable Gain Amplifiers

As seen in [Figure 10](#), page 18, the zooming function is implemented with three programmable gain amplifiers (*PGA*). These are:

- *PGA1*: coarse gain tuning
- *PGA2*: medium gain and offset tuning
- *PGA3*: fine gain and offset tuning. Should be set ON for high linearity data acquisition

All gain and offset settings are realized with ratios of capacitors. The user has control over each *PGA* activation and gain, as well as the offset of stages 2 and 3. These functions are examined hereafter.

1. Over-sampled converters are operated with a sampling frequency  $f_s$  much higher than the input signal's Nyquist rate (typically  $f_s$  is 20-1'000 times the input signal bandwidth). The sampling frequency to throughput ratio is large (typically 10-500). These converters include digital decimation filtering. They are mainly used for high resolution, and/or low-to-medium speed applications.

### 7.1.3 PGA & ADC Enabling

Depending on the application objectives, the user may enable or bypass each *PGA* stage. This is done according to the word *Enable* and the coding given in [Table 7](#). To reduce power dissipation, the *ADC* can also be inactivated while idle.

**Table 7. ADC and PGA Enabling**

Enable (RegACCfg1[3:0])	Block
XXX0 XXX1	ADC disabled ADC enabled
XX0X XX1X	PGA1 disabled PGA1 enabled
X0XX X1XX	PGA2 disabled PGA2 enabled
0XXX 1XXX	PGA3 disabled PGA3 enabled

### 7.2 ZoomingADC Registers

The system has a bank of eight 8-bit registers: six registers are used to configure the acquisition chain (**RegAcCfg0** to **RegAcCfg5**), and two registers are used to store the output code of the analog-to-digital conversion (**RegAcOutMsb** & **Lsb**).

**Table 8. Peripheral Registers to Configure the Acquisition Chain (AC) and to Store the Analog-to-Digital Conversion (ADC) Result**

Register Name	Bit position							
	7	6	5	4	3	2	1	0
RegACOutLsb	Out[7:0] <a href="#">Note 1</a>							
RegACOutMsb	Out[15:8]							
RegACCfg0 Default values:	Start 0, <a href="#">Note 2</a>	SetNelconv 01, <a href="#">Note 3</a>		SetOsr 010, <a href="#">Note 4</a>			Continuous 0, <a href="#">Note 5</a>	- 0, <a href="#">Note 6</a>
RegACCfg1 Default value:	IbAmpAdc 11, <a href="#">Note 7</a>		IbAmpPga 11, <a href="#">Note 8</a>		Enable 0000, <a href="#">Note 9</a>			
RegACCfg2 Default value:	SetFs 00, <a href="#">Note 10</a>		Pga2Gain 00, <a href="#">Note 12</a>		Pga2Offset 0000, <a href="#">Note 14</a>			
RegACCfg3 Default value:	Pga1Gain 0, <a href="#">Note 11</a>	Pga3Gain 0001100, <a href="#">Note 13</a>						
RegACCfg4 Default value:	- 0	Pga3Offset 0000000, <a href="#">Note 15</a>						
RegACCfg5 Default value:	Busy 0, <a href="#">Note 16</a>	Def 0, <a href="#">Note 17</a>	Amux 00000, <a href="#">Note 18</a>				Vmux 0, <a href="#">Note 19</a>	

(r = read; w = write; rw = read & write)

- (1) **Out:** (r) digital output code of the analog-to-digital converter. (*MSB* = *Out[15]*)
- (2) **Start:** (w) setting this bit triggers a single conversion (after the current one is finished). This bit always reads back 0.

- (3) **SetNelconv:** (rw) sets the number of elementary conversions to  $2^{(SetNelconv[1:0])}$ . To compensate for offsets, the input signal is chopped between elementary conversions (1,2,4,8).
- (4) **SetOsr:** (rw) sets the over-sampling rate (*OSR*) of an elementary conversion to  $2^{(3+SetOsr[2:0])}$ . *OSR* = 8, 16, 32, ..., 512, 1024.
- (5) **Continuous:** (rw) setting this bit starts a conversion. When this bit is 1, A new conversion will automatically begin directly when the previous one is finished.
- (6) Reserved
- (7) **IbAmpAdc:** (rw) sets the bias current in the ADC to  $0.25 \times (1 + IbAmpAdc[1:0])$  of the normal operation current (25, 50, 75 or 100% of nominal current). To be used for low-power, low-speed operation.
- (8) **IbAmpPga:** (rw) sets the bias current in the PGAs to  $0.25 \times (1 + IbAmpPga[1:0])$  of the normal operation current (25, 50, 75 or 100% of nominal current). To be used for low-power, low-speed operation.
- (9) **Enable:** (rw) enables the ADC modulator (bit 0) and the different stages of the PGAs (*PGAi* by bit *i*=1,2,3). PGA stages that are disabled are bypassed.
- (10) **SetFs:** (rw) These bits set the over sampling frequency of the acquisition chain. Expressed as a fraction of the oscillator frequency, the sampling frequency is given as: 11 ' 500 kHz, 10 ' 250 kHz, 01 ' 125 kHz, 00 ' 62.5 kHz.
- (11) **Pga1Gain:** (rw) sets the gain of the first stage: 0 ' 1, 1 ' 10.
- (12) **Pga2Gain:** (rw) sets the gain of the second stage: 00 ' 1, 01 ' 2, 10 ' 5, 11 ' 10.
- (13) **Pga3Gain:** (rw) sets the gain of the third stage to *Pga3Gain*[6:0] 1/12.
- (14) **Pga2Offset:** (rw) sets the offset of the second stage between -1 and +1, with increments of 0.2. The *MSB* gives the sign (0 positive, 1 negative); amplitude is coded with the bits *Pga2Offset*[5:0].
- (15) **Pga3Offset:** (rw) sets the offset of the third stage between -5.25 and +5.25, with increments of 1/12. The *MSB* gives the sign (0 positive, 1 negative); amplitude is coded with the bits *Pga3Offset*[5:0].
- (16) **Busy:** (r) set to 1 if a conversion is running.
- (17) **Def:** (w) sets all values to their defaults (*PGA* disabled, max speed, nominal modulator bias current, 2 elementary conversions, over-sampling rate of 32) and starts a new conversion without waiting the end of the preceding one.
- (18) **Amux**(4:0): (rw) *Amux*[4] sets the mode (0 ' differential inputs, 1 ' single ended inputs with *A0*= common reference) *Amux*[3] sets the sign (0 ' straight, 1 ' cross) *Amux*[2:0] sets the channel.
- (19) **Vmux:** (rw) sets the differential reference channel (0 ' *V<sub>BATT</sub>*, 1 ' *V<sub>REF</sub>*).

### 7.3 Input Multiplexers (AMUX and VMUX)

The ZoomingADC has analog inputs *AC0* to *AC7* and reference inputs. Let us first define the differential input voltage *V<sub>IN</sub>* and reference voltage *V<sub>REF,ADC</sub>* respectively as:

$$V_{IN} = V_{INP} - V_{INN} \quad [V]$$

Equation 3

$$V_{REF} = V_{REFP} - V_{REFN} \quad [V]$$

Equation 4

As shown in **Table 9**, the inputs can be configured in two ways: either as 4 differential channels (*V<sub>IN1</sub>* = *AC1* - *AC0*, ..., *V<sub>IN4</sub>* = *AC7* - *AC6*), or *AC0* can be used as a common reference, providing 7 signal paths all referred to *AC0*. The control word for the analog input selection is *Amux*. Notice that the *Amux* bit 4 controls the sign of the input voltage.

**Table 9. Analog Input Selection**

<b>Amux</b> (RegACCfg5[5:1])	<b>V<sub>INP</sub></b>	<b>V<sub>INN</sub></b>	<b>Amux</b> (RegACCfg5[5:1])	<b>V<sub>INP</sub></b>	<b>V<sub>INN</sub></b>
<b>Sign S = 1</b>			<b>Sign S = -1</b>		
00x00	AC1(V <sub>REF</sub> )	AC0(V <sub>SS</sub> )	01x00	AC1(V <sub>SS</sub> )	AC0(V <sub>REF</sub> )

**Table 9. Analog Input Selection**

Amux (RegACCFg5[5:1])	VINP	VINN	Amux (RegACCFg5[5:1])	VINP	VINN
<b>Sign S = 1</b>			<b>Sign S = -1</b>		
00x01	AC3	AC2	01x01	AC2	AC3
00x10	AC5	AC4	01x10	AC4	AC5
00x11	AC7	AC6	01x11	AC6	AC7
10000	AC0(Vss)	AC0(Vss)	11000	AC0(Vss)	AC0(Vss)
10001	AC1(VREF)		11001		AC1(VREF)
10010	AC2		11010		AC2
10011	AC3		11011		AC3
10100	AC4		11100		AC4
10101	AC5		11101		AC5
10110	AC6		11110		AC6
10111	AC7		11111		AC7

Similarly, the reference voltage is chosen among two differential channels ( $V_{REF} = V_{BATT} - V_{SS}$ ,  $V_{REF} = V_{BG} - V_{SS}$  or  $V_{REF} = V_{REF,IN} - V_{SS}$ ) as shown in [Table 10](#). The selection bit is  $V_{mux}$ . The reference inputs  $V_{REFP}$  and  $V_{REFN}$  (common-mode) can be up to the power supply range.

**Table 10. Analog reference Input Selection**

Vmux (RegACCFg5[0])	VREFP	VREFN
0	$V_{REF} = V_{BATT}$	Vss
1	$V_{REF} = V_{BG}$ or $V_{REF,IN}$ <sup>1</sup>	Vss

1. External voltage reference on D1 GPIO pin. See [section 6.3 on page 14](#) about GPIO and "RegMode[0x70]" on page 46.

## 7.4 First Stage Programmable Gain Amplifier (PGA1)

The first stage can have a buffer function (unity gain) or provide a gain of 10 (see [Table 11](#)). The voltage  $V_{D1}$  at the output of  $PGA1$  is:

$$V_{D1} = GD_1 \cdot V_{IN} \quad [V]$$

**Equation 5**

where  $GD_1$  is the gain of  $PGA1$  (in  $V/V$ ) controlled with the  $Pga1Gain$  bit.

**Table 11. PGA1 gain settings**

Pga1Gain bit (RegACCFg3[7])	PGA1 gain [V/V] $GD_1$ [V/V]
0	1
1	10

### 7.5 Second Stage Programmable Gain Amplifier (PGA2)

The second *PGA* has a finer gain and offset tuning capability, as shown in [Table 12](#). The  $V_{D2}$  voltage at the output of *PGA2* is given by:

$$V_{D2} = GD_2 \cdot V_{D1} - GD_{off2} \cdot S \cdot V_{REF} \quad [V]$$

Equation 6

where  $GD_2$  and  $GD_{OFF2}$  are respectively the gain and offset of *PGA2* (in V/V). These are controlled with the words *Pga2Gain[1:0]* and *Pga2Offset[3:0]*.

Table 12. PGA2 gain and offset settings

Pga2Gain bitfield (RegACCFg2[5:4])	PGA2 gain [V/V] $GD_2$ [V/V]	Pga2Offset bitfield (RegACCFg2[3:0])	PGA2 offset $GD_{OFF2}$ [V/V]
00	1	0000	0
01	2	0001	+0.2
10	5	0010	+0.4
11	10	0011	+0.6
		0100	+0.8
		0101	+1
		1000	0
		1001	-0.2
		1010	-0.4
		1011	-0.6
		1100	-0.8
		1101	-1.0

### 7.6 Third Stage Programmable Gain Amplifier (PGA3)

The finest gain and offset tuning is performed with the third and last *PGA* stage, according to the coding of [Table 13](#).

Table 13. PGA3 Gain and Offset Settings

Pga3Gain bitfield (RegACCFg3[6:0])	PGA3 Gain $GD_3$ [V/V]	Pga3Offset bitfield (RegACCFg4[6:0])	PGA3 Offset $GD_{OFF3}$ [V/V]
0000000	0	0000000	0
0000001	1/12 (=0.083)	0000001	+1/12 (=0.083)
...	...	...	...
0000110	6/12	0010000	+16/12
...	...	...	...
0001100	12/12	0100000	32/12
0010000	16/12	...	...
...	...	0111111	+63/12 (=+5.25)
0100000	32/12	1000000	0

**Table 13. PGA3 Gain and Offset Settings**

Pga3Gain bitfield (RegACCfg3[6:0])	PGA3 Gain $GD_3$ [V/V]	Pga3Offset bitfield (RegACCfg4[6:0])	PGA3 Offset $GD_{OFF3}$ [V/V]
...	...	1000001	-1/12 (= -0.083)
1000000	64/12	1000010	-2/12
...	...	...	...
1111111	127/12 (= 10.58)	1010000	-16/12
		...	...
		1100000	-32/12
		...	...
		1111111	-63/12 (= -5.25)

The output of  $PGA3$  is also the input of the  $ADC$ . Thus, similarly to  $PGA2$ , we find that the voltage entering the  $ADC$  is given by:

$$V_{IN,ADC} = GD_3 \cdot V_{D2} - GD_{OFF3} \cdot S \cdot V_{REF} \quad [V]$$

**Equation 7**

where  $GD_3$  and  $GD_{OFF3}$  are respectively the gain and offset of  $PGA3$  (in V/V). The control words are  $Pga3Gain[6:0]$  and  $Pga3Offset[6:0]$ .

To remain within the signal compliance of the  $PGA$  stages (no saturation), the condition:

$$|V_{IN}|, |V_{D1}|, |V_{D2}| < \frac{V_{BATT}}{2}$$

**Equation 8**

must be verified.

To remain within the signal compliance of the  $ADC$  (no saturation), the condition:

$$|V_{IN,ADC}| < \left( \frac{V_{REF}}{2} \right) \left( \frac{OSR - 1}{OSR} \right)$$

**Equation 9**

must be verified.



Finally, combining **Equation 5** to **Equation 7** for the three *PGA* stages, the input voltage  $V_{IN,ADC}$  of the *ADC* is related to  $V_{IN}$  by:

$$V_{IN,ADC} = GD_{TOT} \cdot V_{IN} - GDoff_{TOT} \cdot S \cdot V_{REF} \quad [V]$$

**Equation 10**

where the total *PGA* gain is defined as:

$$GD_{TOT} = GD_3 \cdot GD_2 \cdot GD_1$$

**Equation 11**

and the total *PGA* offset is:

$$GDoff_{TOT} = GDoff_3 + GD_3 \cdot GDoff_2$$

**Equation 12**

### 7.6.1 *PGA* Ranges

**Figure 11** and **Figure 12** illustrates the limits for the maximal conversion precision according to the common mode voltage ( $V_{COMMON}$ ), the *ADC* over-sampling frequency ( $f_s$ ) and *PGA* gains. The best linearity performances can be

obtained only below these limits, as depicted in [Figure 11](#) if the supply voltage ( $V_{BATT}$ ) is below 4.2V and as depicted in [Figure 12](#) if the supply voltage ( $V_{BATT}$ ) is above 4.2V.

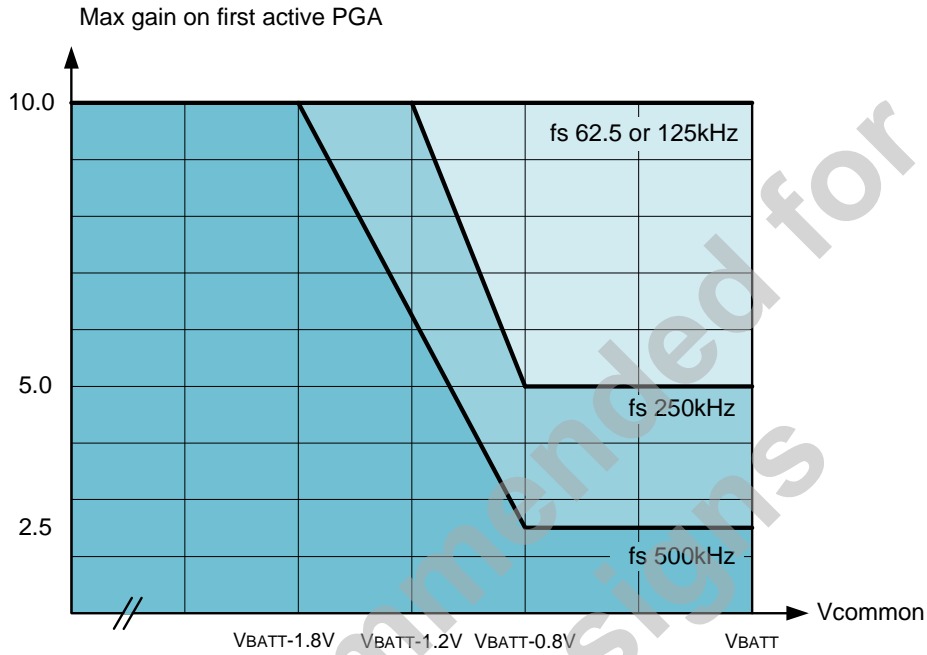

Figure 11. Common mode input range on PGA for  $V_{BATT}$  below 4.2V

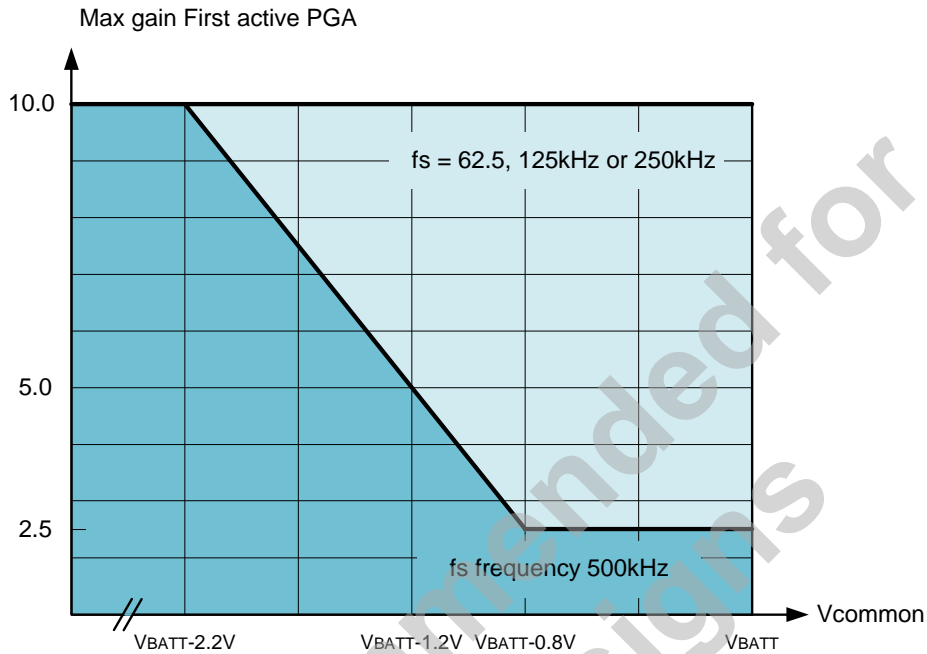

Figure 12. Common mode input range on PGA for  $V_{BATT}$  above 4.2V

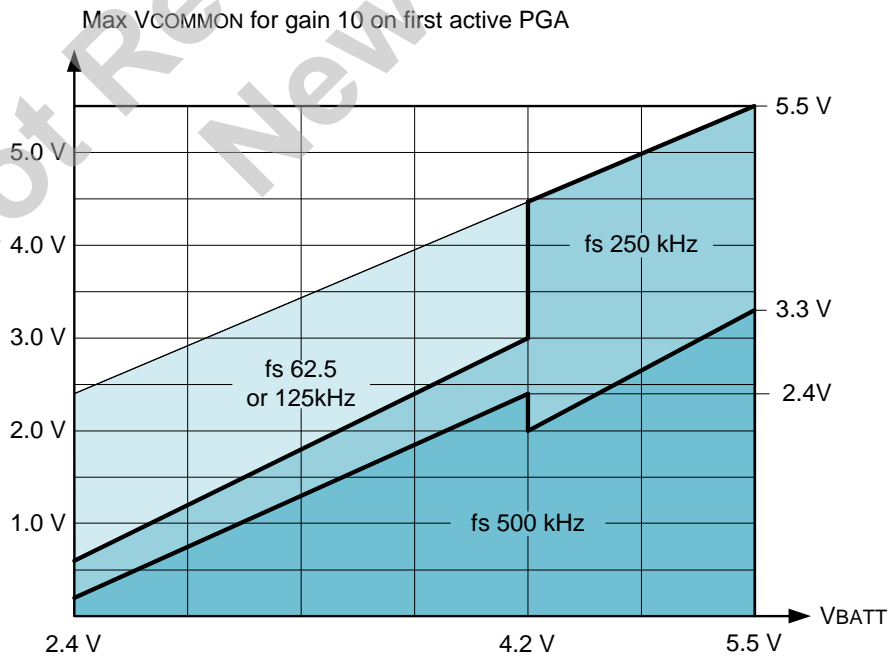

Figure 13. Common mode input range on PGA vs  $V_{BATT}$

## 7.7 Analog-to-Digital Converter (ADC)

The main performance characteristics of the ADC (resolution, conversion time, etc.) are determined by three programmable parameters. The setting of these parameters and the resulting performances are described later.

- $f_s$ : Over-sampling frequency
- $OSR$ : Over-Sampling Ratio
- $NELCONV$ : Number of Elementary Conversions

### 7.7.1 Conversion Sequence

A conversion is started each time the bit *Start* or the *Def* bit is set. As depicted in [Figure 14](#), a complete analog-to-digital conversion sequence is made of a set of  $NELCONV$  elementary incremental conversions and a final quantization step. Each elementary conversion is made of  $(OSR+1)$  over-sampling periods  $T_s=1/f_s$ , i.e.:

$$T_{ELCONV} = (OSR+1) / f_s \quad [s]$$

**Equation 13**

The result is the mean of the elementary conversion results. An important feature is that the elementary conversions are alternatively performed with the offset of the internal amplifiers contributing in one direction and the other to the output code. Thus, converter internal offset is eliminated if at least two elementary sequences are performed (i.e. if  $NELCONV \geq 2$ ). A few additional clock cycles are also required to initiate and end the conversion properly.

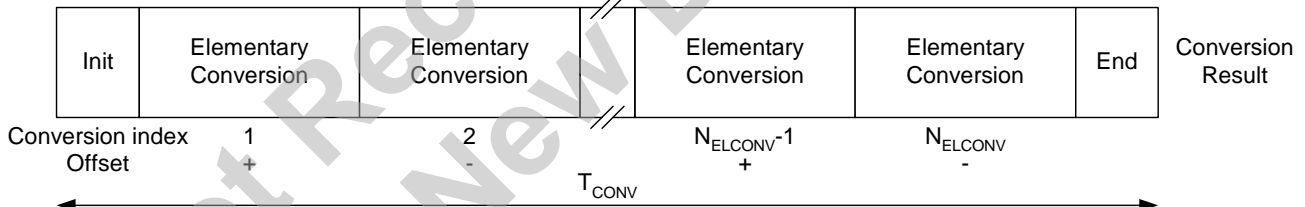

*Figure 14. Analog-to-Digital Conversion Sequence*

---

**Note** The internal bandgap reference state may be forced High or Low, or may be set to toggle during conversion at either the same rate or half the rate of the Elementary Conversion. This may be useful to help eliminate bandgap related internal offset voltage and  $1/f_s$  noise.

---

### 7.7.2 Over-Sampling Frequency (fs)

The word *SetFs[1:0]* (see [Table 14](#)) is used to select the over-sampling frequency *fs*. The over-sampling frequency is derived from the 4MHz oscillator clock.

**Table 14. Sampling frequency settings**

SetFs bitfield (RegACCFg2[7:6])	Over-Sampling Frequency fs [Hz]
00	62.5 kHz
01	125 kHz
10	250 kHz
11	500 kHz

### 7.7.3 Over-Sampling Ratio (OSR)

The over-sampling ratio (*OSR*) defines the number of integration cycles per elementary conversion. Its value is set with the word *SetOsr[2:0]* in power of 2 steps (see [Table 15](#)) given by:

$$OSR = 2^{3+SetOsr[2:0]} \quad [-]$$

**Equation 14**

**Table 15. Over-sampling ratio settings**

SetOsr[2:0] (RegACCFg4[4:2])	Over-Sampling Ratio OSR [-]
000	8
001	16
010	32
011	64
100	128
101	256
110	512
111	1024

### 7.7.4 Number of Elementary Conversions (Nelconv)

As mentioned previously, the whole conversion sequence is made of a set of *NELCONV* elementary incremental conversions. This number is set with the word *SetNelconv[1:0]* in power of 2 steps (see [Table 16](#)) given by:

$$N_{ELCONV} = 2^{SetNelconv[1:0]} \quad [-]$$

**Equation 15**

**Table 16. Number of elementary conversion**

SetOsr[2:0] (RegACCfg[4:2])	# of Elementary Conversion NELCONV [-]
00	1
01	2
10	4
11	8

As already mentioned,  $NELCONV$  must be equal or greater than 2 to reduce internal amplifier offsets.

### 7.7.5 Resolution

The theoretical resolution of the ADC, without considering thermal noise, is given by:

$$n = 2 \cdot \log_2(OSR) + \log_2(N_{ELCONV}) \quad [bit]$$

**Equation 16**

Figure 15. Resolution vs. SetOsr[2:0] and SetNelconv[2:0]

Using look-up [Table 17](#) or the graph plotted in [Figure 15](#), resolution can be set between 6 and 16 bits. Notice that, because of 16-bit register use for the ADC output, **practical resolution is limited to 16 bits**, i.e.  $n = 16$ . Even if the

resolution is truncated to 16 bit by the output register size, it may make sense to set  $OSR$  and  $N_{ELCONV}$  to higher values in order to reduce the influence of the thermal noise in the PGA .

**Table 17. Resolution<sup>1</sup> vs. SetOsr and SetNelconv settings**

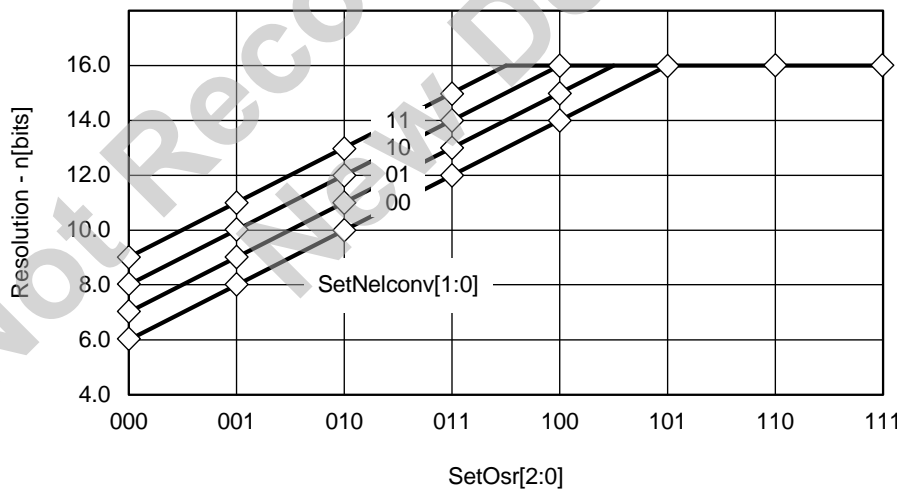
SetOsr control bits	SetNelconv control bits			
	'00'	'01'	'10'	'11'
'000'	6	7	8	9
'001'	8	9	10	11
'010'	10	11	12	13
'011'	12	13	14	15
'100'	14	15	16	16
'101'	16	16	16	16
'110'	16	16	16	16
'111'	16	16	16	16

1. In shaded area, the resolution is truncated to 16 bits due to output register size **RegA-COut[15:0]**

### 7.7.6 Conversion Time & Throughput

As explained in [Figure 15](#), conversion time is given by:

$$T_{CONV} = (N_{ELCONV} \cdot (OSR+1) + 1) / f_s \quad [s]$$

**Equation 17**

and throughput is then simply  $1/T_{CONV}$ . For example, consider an over-sampling ratio of 256, 2 elementary conversions, and a sampling frequency of 500 kHz ( $SetOsr = "101"$ ,  $SetNelconv = "01"$  and  $SetFs = "00"$ ). In this case, using [Table 18](#), the conversion time is 515 sampling periods, or 1.03ms. This corresponds to a throughput of 971Hz in continuous-time mode. The plot of [Figure 16](#) illustrates the classic trade-off between resolution and conversion time.

**Table 18. Normalized conversion time (Tconv x fs) vs. SetOsr and SetNelconv settings<sup>1</sup>**

SetOsr bits OSR	SetNelconv control bits NELCONV			
	'00' 1	'01' 2	'10' 4	'11' 8
'000'	10	19	37	73
'001'	18	35	69	137
'010'	34	67	133	265
'011'	66	131	261	521

**Table 18. Normalized conversion time ( $T_{conv} \times f_s$ ) vs. SetOsr and SetNelconv settings<sup>1</sup>**

SetOsr bits OSR	SetNelconv control bits NELCONV			
	'00' 1	'01' 2	'10' 4	'11' 8
'100'	130	259	517	1033
'101'	258	515	1029	2057
'110'	514	1027	2053	4105
'111'	1026	2051	4101	8201

1. Normalized to sampling period  $1/f_s$

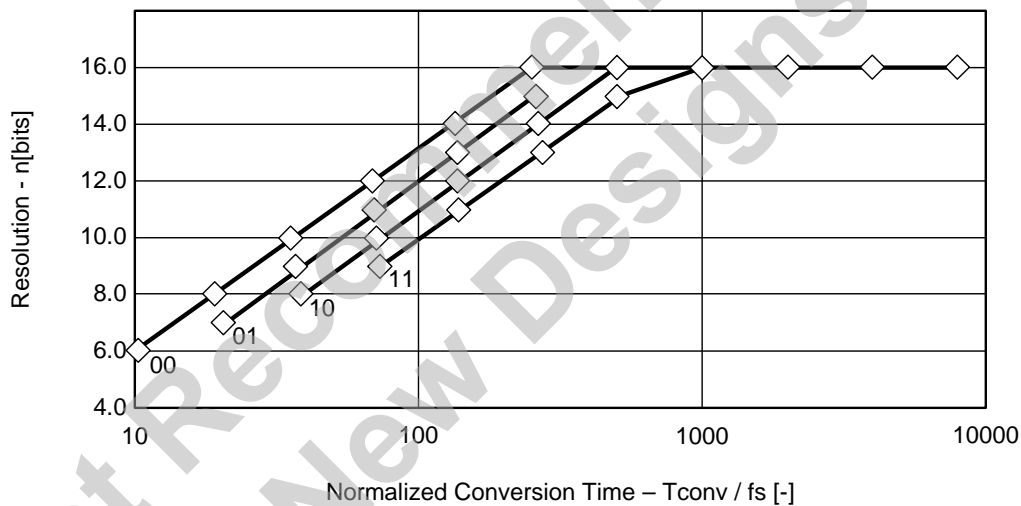

Figure 16. Resolution vs. normalized<sup>1</sup> conversion time for different SetNelconv[1:0]

1. Normalized Conversion Time -  $T_{CONV}/f_s$

### 7.7.7 Continuous-Time vs. On-Request Conversion

The ADC can be operated in two distinct modes: "continuous-time" and "on-request" modes (selected using the bit *Continuous*).



In "continuous-time" mode, the input signal is repeatedly converted into digital. After a conversion is finished, a new one is automatically initiated. The new value is then written in the result register, and the corresponding internal trigger pulse is generated. This operation is sketched in **Figure 17**. The conversion time in this case is defined as  $T_{CONV}$ .

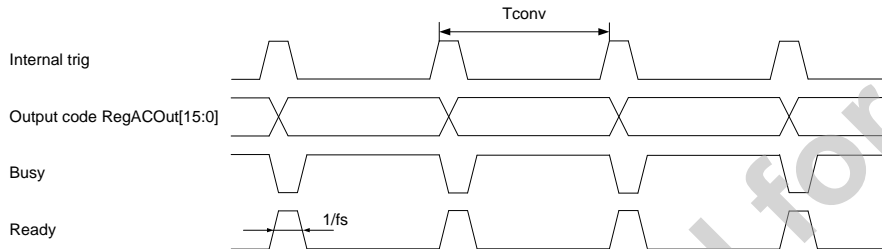

Figure 17. ADC "Continuous-Time" Operation

In the "on-request" mode, the internal behavior of the converter is the same as in the "continuous-time" mode, but the conversion is initiated on user request (with the *Start* bit). As shown in **Figure 18**, the conversion time is also  $T_{CONV}$ .

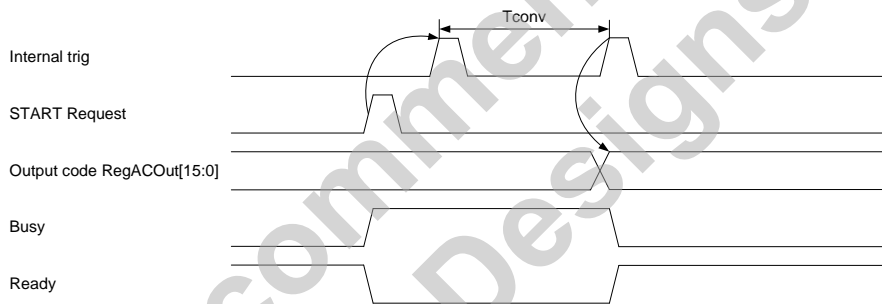

Figure 18. ADC "On-Request" Operation

### 7.7.8 Output Code Format

The ADC output code is a 16-bit word in two's complement format (see **Table 19**). For input voltages outside the range, the output code is saturated to the closest full-scale value (i.e. 0x7FFF or 0x8000). For resolutions smaller than 16 bits, the non-significant bits are forced to the values shown in **Table 20**. The output code, expressed in *LSBs*, corresponds to:

$$OUT_{ADC} = 2^{16} \cdot \frac{V_{IN,ADC}}{V_{REF}} \cdot \frac{OSR + 1}{OSR}$$

Equation 18

Recalling **Equation 10**, **page 25**, this can be rewritten as:

$$OUT_{ADC} = 2^{16} \cdot \frac{V_{IN}}{V_{REF}} \cdot \left( GD_{TOT} - GD_{offTOT} \cdot S \cdot \frac{V_{REF}}{V_{IN}} \right) \cdot \frac{OSR + 1}{OSR} \quad [LSB]$$

Equation 19

where, from [Equation 11](#) and [Equation 12](#), the total PGA gain and offset are respectively:

$$GD_{TOT} = GD_3 \cdot GD_2 \cdot GD_1$$

**Equation 20**

and:

$$GDoff_{TOT} = GDoff_3 + GD_3 \cdot GDoff_2$$

**Equation 21**
**Table 19. Basic ADC Relationships (example for: VREF = 5V, OSR = 512, n = 16bits)**

ADC Input Voltage $V_{IN,ADC}$	% of Full Scale (FS)	Output in LSBs	Hexadecimal Output Code
+2.49505 V	+0.5 x FS	$+2^{15}-1 = 32'767$	7FFF
+2.49497 V	...	$+2^{15}-2 = 32'766$	7FFE
...	...	...	...
+76.145 $\mu$ V	...	+1	0001
0	0	0	0000
-76.145 $\mu$ V	...	-1	FFFF
...	...	...	...
-2.49505 V	...	$-2^{15}-1 = -32'767$	8001
-2.49513 V	-0.5 x FS	$-2^{15} = -32'768$	8000

**Table 20. Last forced LSBs in conversion output register for resolution settings smaller than 16bits<sup>1</sup>**

SetOsr[2:0]	SetNelconv = '00'	SetNelconv = '01'	SetNelconv = '10'	SetNelconv = '11'
'000'	1000000000	100000000	10000000	1000000
'001'	100000000	10000000	100000	10000
'010'	100000	10000	1000	100
'011'	1000	100	10	1
'100'	10	1	-	-
'101'	-	-	-	-
'110'	-	-	-	-
'111'	-	-	-	-

1. (n<16) (RegACOutMsb[7:0] & RegACOutLsb[7:0])

The equivalent *LSB* size at the input of the *PGA* chain is:

$$LSB = \frac{1}{2^n} \cdot \frac{V_{REF}}{GD_{TOT}} \cdot \frac{OSR}{OSR + 1} \quad [V/V]$$

**Equation 22**

Notice that the input voltage  $V_{IN,ADC}$  of the *ADC* must satisfy the condition:

$$|V_{IN,ADC}| \leq \frac{1}{2} \cdot (V_{REFP} - V_{REFN}) \cdot \frac{OSR}{OSR + 1}$$

**Equation 23**

to remain within the *ADC* input range.

### 7.7.9 Power Saving Modes

During low-speed operation, the bias current in the *PGAs* and *ADC* can be programmed to save power using the control words *IbAmpPga[1:0]* and *IbAmpAdc[1:0]* (see [Table 21](#)). If the system is idle, the *PGAs* and *ADC* can even be disabled, thus, reducing power consumption to its minimum. This can considerably improve battery lifetime.

**Table 21. ADC & PGA power saving modes and maximum sampling frequency**

<b>IbAmpAdc [1:0]</b>	<b>IbAmpPga [1:0]</b>	<b>ADC Bias Current</b>	<b>PGA Bias Current</b>	<b>Max. fs [kHz]</b>
00		1/4 x IADC		125
01		1/2 x IADC		250
11		IADC		500
	00		1/4 x I <sub>PGA</sub>	125
	01		1/2 x I <sub>PGA</sub>	250
	11		I <sub>PGA</sub>	500

## 8 Application hints

### 8.1 Power Reduction

The ZoomingADC is particularly well suited for low-power applications. When very low power consumption is of primary concern, such as in battery operated systems, several parameters can be used to reduce power consumption as follows:

- Operate the acquisition chain with a reduced supply voltage  $V_{BATT}$ .
- Disable the PGAs which are not used during analog-to-digital conversion with  $Enable[3:0]$ .
- Disable all PGAs and the ADC when the system is idle and no conversion is performed.
- Use lower bias currents in the PGAs and the ADC using the control words  $IbAmpPga[1:0]$  and  $IbAmpAdc[1:0]$ .
- Reduce sampling frequency.

Finally, remember that power reduction is typically traded off with reduced linearity, larger noise and slower maximum sampling speed.

Not Recommended for  
New Designs

**8.2 Gain Configuration Flow**

The diagram below shows the flow to set the gain of your configuration:

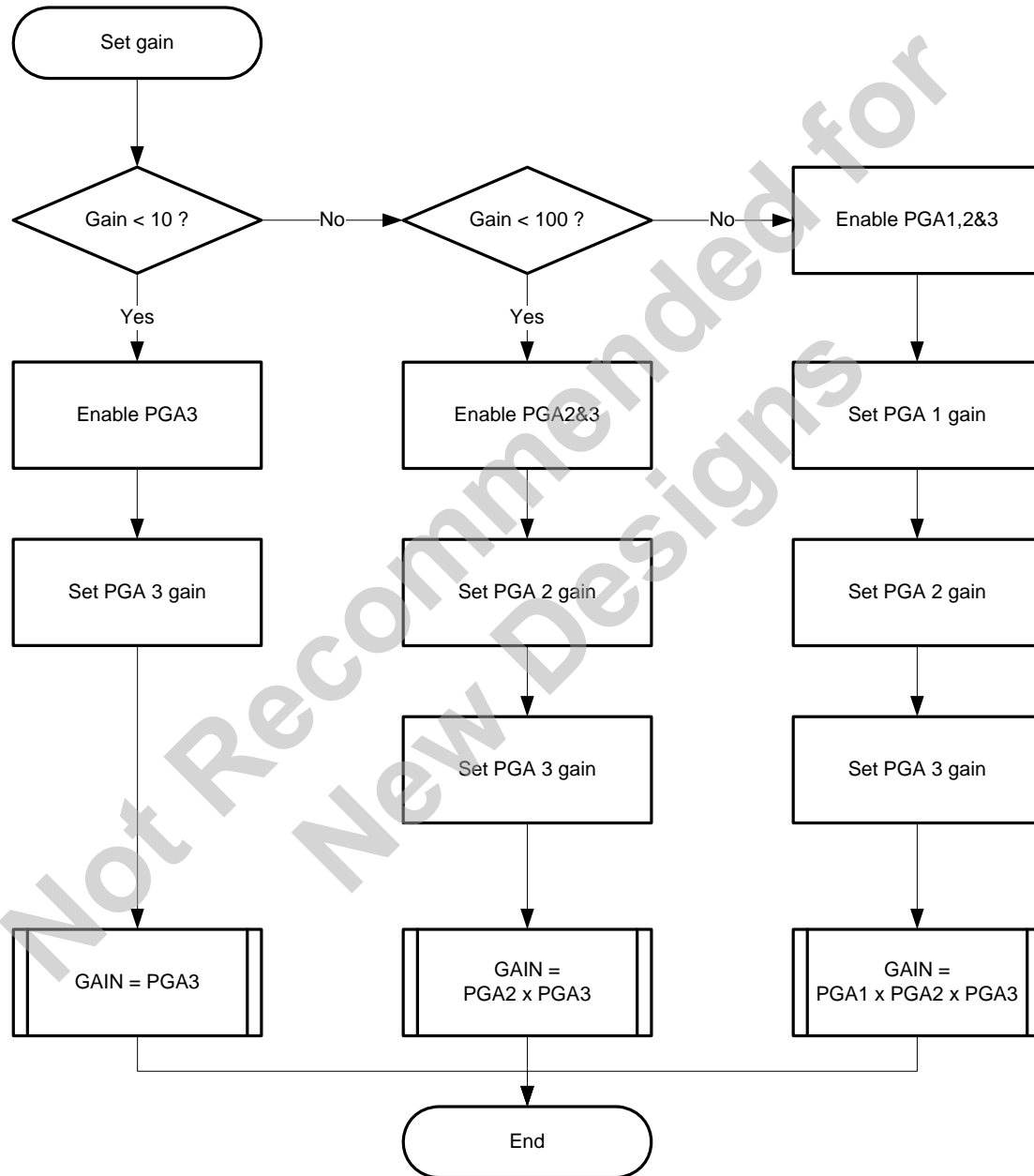

Figure 19. Gain configuration flowchart

## 9 I2C Interface

The I2C interface gives access to the chip registers. It complies with the I2C protocol specifications, restricted to the slave side of the communication.

The device uses a Generic Fast-Mode (400 KHz) I2C Slave Interface in accordance with the I2C bus standard. Its characteristics can be summarized as follows:

### 9.1 General Features

- Slave only operation
- Fast mode operation (up to 400 kHz)
- Combined read and write mode support
- General call reset support
- 7-bits default slave address 0x48. Can be changed by fuse and by pinout (D0 and D1).

The interface handles I2C communication at the transaction level. A read transaction is an external request to get the content of system memory location and a write transaction is an external request to write the content of a system memory location.

The default I2C slave address is 0x48, 1001000 in binary. This is the standard part I2C slave address. Other addresses between 1000000 and 1001111 are available.

### 9.2 Other Slave Address Options

Slave address might be differentiated (2 fuse-programmed bits + 2 LSBs given by 2 GPIO inputs):

- Address bit 3 and bit 2 (100**XX**xx ) can be changed in production by fuse. Other values are available by special request. Please contact Semtech Sales for more information. Otherwise, default value is "00".
- The last significant bits (100xx**XX**) can be defined by the GPIO pin D0 and D1. This mode is not set by default at startup, it must be activated in a register with a command. Default value is "00".

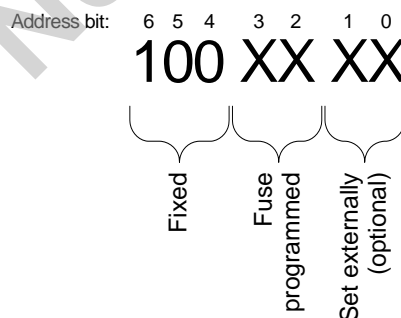

### 9.2.1 Address Set Externally

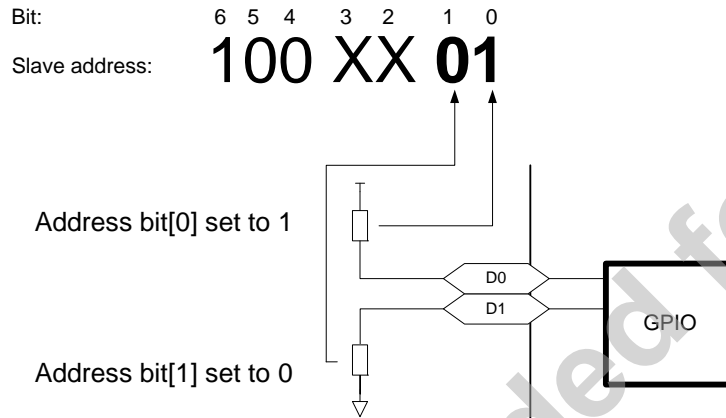

Figure 20. Example of I2C address set by external resistors

The GPIO are set as output low at startup, so a resistor should be connected to the pad to avoid shortcut at startup. After startup, the master I2C can send a command (0x96 in RegExtAdd[0x43]) at the default I2C address to change I2C mode and set D0 and D1 as input address bits.

If several SX87xx devices are connected on the same bus, the master MCU must send the command to each device simultaneously using the default address. All SX87xx devices will receive the command at the same time. The master MCU must ensure that the command has been received by asking each slave device at their new address.

### 9.3 I2C General Call Reset

The device respond to the I2C general call address (0000000) if the eighth bit is '0'. The devices acknowledge the general call address and respond to commands in the second byte. If the second byte is 00000110 (06h), the device reset the internal registers and enter power-down mode.

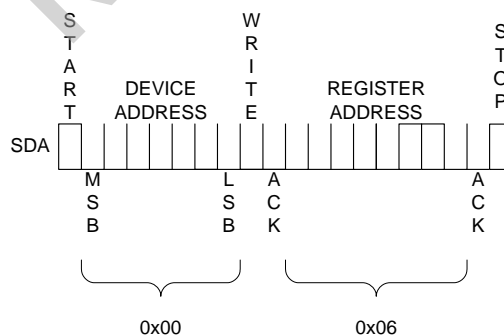

Figure 21. I2C General Call reset frame

## 9.4 I2C Register Access

### 9.4.1 Writing a Register

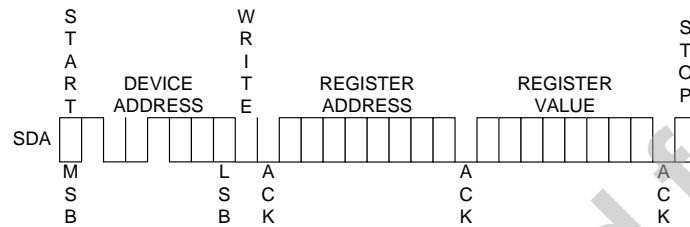

Figure 22. I2C timing diagram for writing to a register

### 9.4.2 Reading in a Register

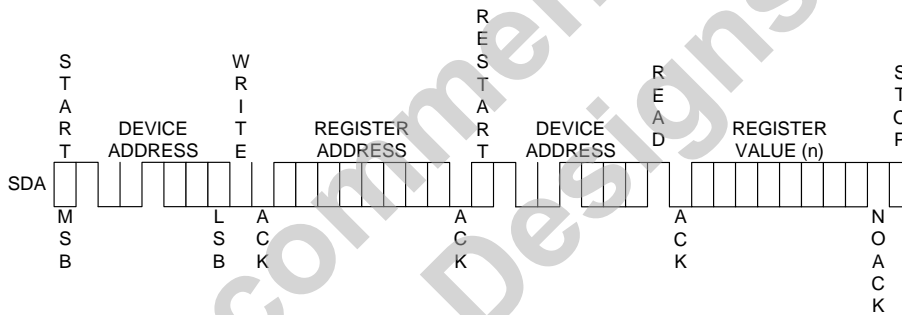

Figure 23. I2C timing diagram for reading from a register

### 9.4.3 Writing in Several Consecutive Registers

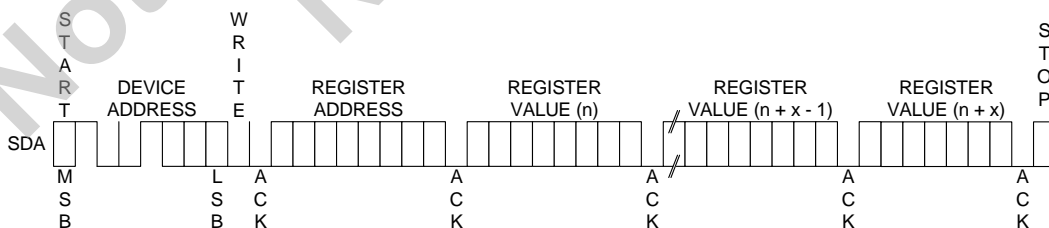

Figure 24. I2C timing diagram for multiple writing to registers



**9.4.4 Reading from Several Consecutive Registers**

Figure 25. I2C timing diagram for multiple reading from a register

Not Recommended for New Designs

## 10 Register Memory Map and Description

### 10.1 Register Map

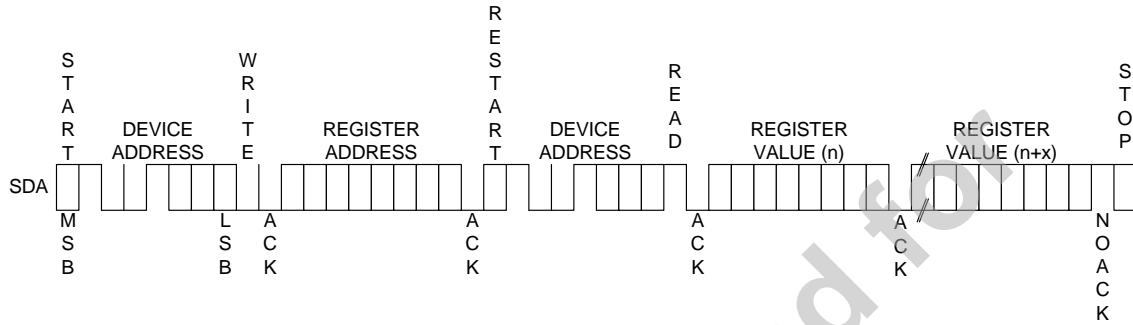
**Table 22** below describes the register/memory map that can be accessed through the I2C interface. It indicates the register name, register address and the register contents.

**Table 22. Register Map**

Address	Register	Bit	Description
<b>RC Register</b>			
0x30	RegRCen	1	RC oscillator control
<b>GPIO Registers</b>			
0x40	RegOut	8	D0 to D3 pads data output and direction control
0x41	RegIn	4	D0 to D3 pads input data
0x42	RegTimeout	1	Enable/Disable I2C timeout
0x43	RegExtAdd	8	Set address by external pin
<b>ADC Registers</b>			
0x50	RegACOutLsb	8	LSB of ADC result
0x51	RegACOutMsb	8	MSB of ADC result
0x52	RegACCfg0	7	ADC conversion control
0x53	RegACCfg1	8	ADC conversion control
0x54	RegACCfg2	8	ADC conversion control
0x55	RegACCfg3	8	ADC conversion control
0x56	RegACCfg4	7	ADC conversion control
0x57	RegACCfg5	8	ADC conversion control
<b>Mode Register</b>			
0x70	RegMode	8	Chip operating mode register

### 10.2 Registers Descriptions

The register descriptions are presented here in ascending order of Register Address. Some registers carry several individual data fields of various sizes; from single-bit values (e.g. flags), upwards. Some data fields are spread across multiple registers. After power on reset the registers will have the values indicated in the tables "Reset" column. Please write the "Reserved" bits with their reset values.

**10.2.1 RC Register**
**Table 23. RegRCen[0x30]**

Bit	Bit Name	Mode	Reset	Description
7:1	-	r	0000000	Reserved
0	RCEn	rw	1	Enables RC oscillator. Set 0 for low power mode.

**10.2.2 GPIO Registers**
**Table 24. RegOut[0x40]**

Bit	Bit Name	Mode	Reset	Description
7	D3Dir	rw	1	D3 pad direction. 1 : Output 0 : Input
6	D2Dir	rw	1	D2 pad direction. 1 : Output 0 : Input
5	D1Dir	rw	1	D1 pad direction. 1 : Output 0 : Input
4	D0Dir	rw	1	D0 pad direction. 1 : Output 0 : Input
3	D3Out	rw	0	D3 pad output value. Only valid when D3Dir=1
2	D2Out	rw	0	D2 pad output value. Only valid when D2Dir=1
1	D1Out	rw	0	D1 pad output value. Only valid when D1Dir=1 and VrefD1In=0
0	D0Out	rw	0	D0 pad output value. Only valid when D0Dir=1 and VrefD1Out=0

**Table 25. RegIn[0x41]**

Bit	Bit Name	Mode	Reset	Description
7:4	-	r	0000	Reserved
3	D3In	r	-	D3 pad value
2	D2In	r	-	D2 pad value
1	D1In	r	-	D1 pad value
0	D0In	r	-	D0 pad value

**Table 26. RegTimeout[0x42]**

Bit	Bit Name	Mode	Reset	Description
7:6	-	rw	00	Reserved
5	Timeout	w	0	0 : Disabled 1 : Enabled

**Table 26. RegTimeout[0x42]**

Bit	Bit Name	Mode	Reset	Description
4:0	-	rw	00000	Reserved

**Table 27. RegExtAdd[0x43]**

Bit	Bit Name	Mode	Reset	Description
7:0	ExternalRd	rw	00000000	Write the 0x96 value into this register to set the two LSbits of the I2C address by external (D0 and D1).

### 10.2.3 ZADC Registers

**Table 28. RegACOutLsb[0x50]**

Bit	Name	Mode	Reset	Description
7:0	Out[7:0]	r	00000000	LSB of the ADC result

**Table 29. RegACOutMsb[0x51]**

Bit	Name	Mode	Reset	Description
7:0	Out[15:8]	r	00000000	MSB of the ADC result

**Table 30. RegACCfg0[0x52]**

Bit	Name	Mode	Reset	Description
7	Start	rw	0	Starts an ADC conversion
6:5	SetNelconv	rw	01	Sets the number of elementary conversion to $2^{\text{SetNelconv}}$ . To compensate for offset the signal is chopped between elementary conversion.
4:2	SetOsr	rw	010	Sets the ADC over-sampling rate of an elementary conversion to $2^{3+\text{SetOsr}}$ .
1	Continuous	rw	0	Sets the continuous ADC conversion mode
0	-	r	0	Reserved

**Table 31. RegACCfg1[0x53]**

Bit	Name	Mode	Reset	Description
7:6	IbAmpAdc	rw	11	Bias current selection for the ADC
5:4	IbAmpPga	rw	11	Bias current selection for the PGA

**Table 31. RegACCFg1[0x53]**

Bit	Name	Mode	Reset	Description
3	Enable	rw	0	PGA3 enable
2		rw	0	PGA2 enable
1		rw	0	PGA1 enable
0		rw	0	ADC enable

**Table 32. RegACCFg2[0x54]**

Bit	Name	Mode	Reset	Description
7:6	SetFs	rw	00	ADC Sampling Frequency selection
5:4	Pga2Gain	rw	00	PGA2 gain selection
3:0	Pga2Offset	rw	0000	PGA2 offset selection

**Table 33. RegACCFg3[0x55]**

Bit	Name	Mode	Reset	Description
7	Pga1Gain	rw	0	PGA1 gain selection
6:0	Pga3Gain	rw	0001100	PGA3 gain selection

**Table 34. RegACCFg4[0x56]**

Bit	Name	Mode	Reset	Description
7	-	rw	0	Reserved
6:0	Pga3Offset	rw	0000000	PGA3 offset selection

**Table 35. RegACCFg5[0x57]**

Bit	Name	Mode	Reset	Description
7	Busy	r	0	ADC activity flag
6	Def	rw	0	Selects ADC and PGA default configuration, starts an ADC conversion
5:1	Amux	rw	00000	Input channel configuration selector
0	Vmux	rw	0	Reference channel selector 0 : VBATT 1 : VREF

**10.2.4 Mode Registers**
**Table 36. RegMode[0x70]**

Bit	Name	Mode	Reset	Description
7	-	r	1	reserved
6	-	r	0	reserved
5:4	Chopper	rw	00	VREF chopping control. <b>Note 1</b> 11 : Chop at NELCONV/2 rate 10 : Chop at NELCONV rate 01 : Chop state=1 00 : Chop state=0
3	MultForceOn	rw	0	Force charge pump On. Takes priority. <b>Note 2</b>
2	MultForceOff	rw	1	Force charge pump Off. <b>Note 2</b>
1	VrefD0Out	rw	0	Enable VREF output on D0 pin
0	VrefD1In	rw	0	Enable external VREF on D1 pin

- (1) The chop control is to allow chopping of the internal bandgap reference. This may be useful to help eliminate bandgap related internal offset voltage and 1/f noise. The bandgap chop state may be forced High or Low, or may be set to toggle during conversion at either the same rate or half the rate of the Elementary Conversion. (See Conversion Sequence in the ZoomingADC description).
- (2) The internal charge pump may be forced On when  $V_{BATT}$  supply is below 4.2V or Off when  $V_{BATT}$  supply is above 4.2V. Enabling the charge pump increase the current consumption. If the ADC is not being run at full rate or full accuracy then it may operate sufficiently well when  $V_{BATT}$  is less than 4.2V and internal charge pump forced Off.

## 11 Typical Performances

---

**Note** The graphs and tables provided following this note are statistical summary based on limited number of samples and are provided for informational purposes only. The performance characteristics listed herein are not tested or guaranteed. In some graphs or tables, the data presented may be outside the specified operating range and therefore outside the warranted range.

---

### 11.1 Input impedance

The PGAs of the ZoomingADC are a switched capacitor based blocks (see Switched Capacitor Principle section). This means that it does not use resistors to fix gains, but capacitors and switches. This has important implications on the nature of the input impedance of the block.

Using switched capacitors is the reason why, while a conversion is done, the input impedance on the selected channel of the PGAs is inversely proportional to the sampling frequency  $f_s$  and to stage gain as given in [Equation 24](#).

$$Z_{in} \geq \frac{1}{f_s \cdot (C_g \cdot gain + C_p)} \quad [\Omega]$$

**Equation 24**

The input impedance observed is the input impedance of the first PGA stage that is enabled or the input impedance of the ADC if all three stages are disabled.

$C_g$  multiplied by  $gain$  is the equivalent gain capacitor and  $C_p$  is the parasitic capacitor of the first enabled stage. The values for each ZoomingADC bloc are provided in [Table 37](#):

**Table 37. Capacitor values**

Acquisition Chain Stage	Gain capacitor $C_g$	Parasitic capacitor $C_p$	Units
PGA1	0.45	1.04	pF
PGA2	0.54	1.2	pF
PGA3	0.735	1.53	pF
ADC	2.4		pF

PGA1 (with a gain of 10) and PGA2 (with a gain of 10) have each a minimum input impedance of 300 kOhm at  $f_s = 500$  kHz. PGA3 (with a gain of 10) have a minimum input impedance of 250 kOhm at  $f_s = 500$  kHz. Larger input impedance can be obtained by reducing the gain and/or by reducing the over-sampling frequency  $f_s$ . Therefore, with a gain of 1 and a sampling frequency of 62.5 kHz,  $Z_{in} > 10.2$  MOhm for PGA1.

The input impedance on channels that are not selected is very high (>10MOhm).

### 11.1.1 Switched Capacitor Principle

Basically, a switched capacitor is a way to emulate a resistor by using a capacitor. The capacitors are much easier to realize on CMOS technologies and they show a very good matching precision.

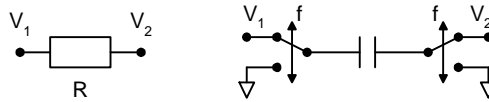

Figure 26. The Switched Capacitor Principle

A resistor is characterized by the current that flows through it (positive current leaves node  $V_1$ ):

$$I = \frac{V_1 - V_2}{R} \quad [A]$$

Equation 25

One can verify that the mean current leaving node  $V_1$  with a capacitor switched at frequency  $f$  is:

$$\langle I \rangle = (V_1 - V_2) \cdot f \cdot C \quad [A]$$

Equation 26

Therefore as a mean value, the switched capacitor  $1/(f \times C)$  is equivalent to a resistor.

It is important to consider that this is only a mean value. If the current is not integrated (low impedance source), the impedance is infinite during the whole time but the transition.

What does it mean for the ZoomingADC?

If the  $f_s$  clock is reduced, the mean impedance is increased. By dividing the  $f_s$  clock by a factor 10, the impedance is increased by a factor 10.

One can reduce the capacitor that is switched by using an amplifier set to its minimal gain. In particular if  $PGA1$  is used with gain 1, its mean impedance is 10x bigger than when it is used with gain 10.

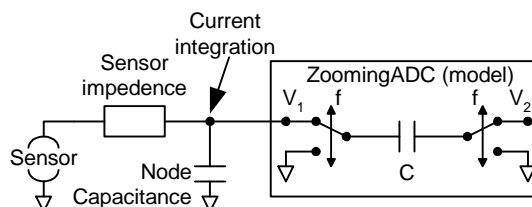

Figure 27. The Switched Capacitor Principle

One can increase the effective impedance by increasing the electrical bandwidth of the sensor node so that the switching current is absorbed through the sensor before the switching period is over. Measuring the sensor node will



show short voltage spikes at the frequency  $f_s$ , but these will not influence the measurement. Whereas if the bandwidth of the node is lower, no spikes will arise, but a small offset can be generated by the integration of the charges generated by the switched capacitors, this corresponds to the mean impedance effect.

**Notes:**

- (1) One can increase the mean input impedance of the ZoomingADC by lowering the acquisition clock  $f_s$ .
- (2) One can increase the mean input impedance of the ZoomingADC by decreasing the gain of the first enabled amplifier.
- (3) One can increase the effective input impedance of the ZoomingADC by having a source with a high electrical bandwidth (sensor electrical bandwidth much higher than  $f_s$ ).

## 11.2 Frequency Response

The incremental ADC is an over-sampled converter with two main blocks: an analog modulator and a low-pass digital filter. The main function of the digital filter is to remove the quantization noise introduced by the modulator. This filter determines the frequency response of the transfer function between the output of the ADC and the analog input  $V_{IN}$ . Notice that the frequency axes are normalized to one elementary conversion period  $OSR / f_s$ . The plots of [Figure 28](#), [page 50](#) also show that the frequency response changes with the number of elementary conversions  $N_{ELCONV}$  performed. In particular, notches appear for  $N_{ELCONV} \geq 2$ . These notches occur at:

$$f_{NOTCH} = \frac{i \cdot f_s}{OSR \cdot N_{ELCONV}} \quad \text{For } i = 1, 2, \dots, (N_{ELCONV} - 1)$$

**Equation 27**

and are repeated every  $f_s / OSR$ .

Information on the location of these notches is particularly useful when specific frequencies must be filtered out by the acquisition system. This chip has no dedicated 50/60 Hz rejection filtering but some rejection can be achieved by using [Equation 27](#) and setting the appropriate values of  $OSR$ ,  $f_s$  and  $N_{ELCONV}$ .

**Table 38. 50/60 Hz Line Rejection Examples**

Rejection [Hz]	$f_{NOTCH}$ [Hz]	$f_s$ [kHz]	OSR [-]	$N_{ELCONV}$ [-]
60	61	125	1024	2
	61	250	1024	4
	61	500	1024	8
50	53	62.5	1024	8
	46	62.5	1024	4
	46	125	1024	8

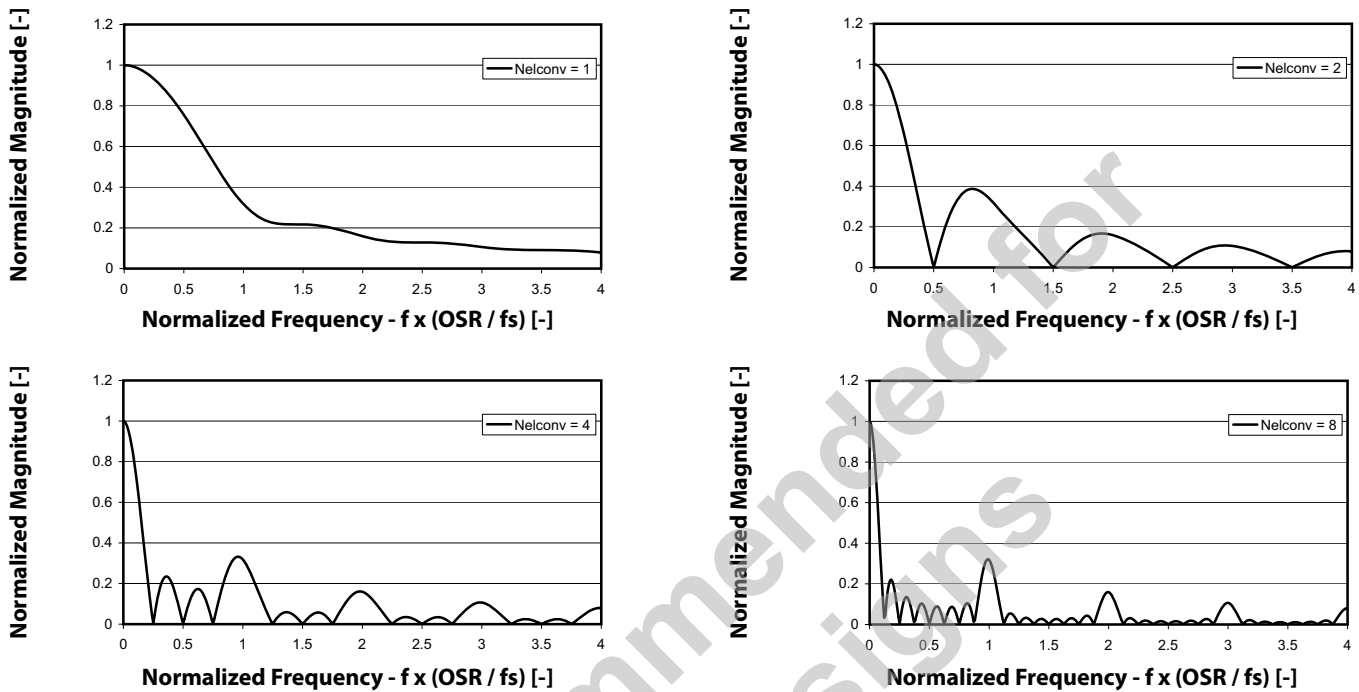

Figure 28. Frequency Response. Normalized Magnitude vs. Frequency for Different NELCONV

## 11.3 Linearity

### 11.3.1 Integral Non-Linearity

The different *PGA* stages have been designed to find the best compromise between the noise performance, the integral non-linearity and the power consumption. To obtain this, the first stage has the best noise performance and the third stage the best linearity performance. For large input signals (small *PGA* gains, i.e. up to about 50), the noise added by the *PGA* is very small with respect to the input signal and the second and third stage of the *PGA* should be used to get the best linearity. For small input signals (large gains, i.e. above 50), the noise level in the *PGA* is important and the first stage of the *PGA* should be used.

The following figures show the Integral non linearity for different gain settings over the chip temperature range

**11.3.1.1 Gain 1**

$V_{BATT}=5V$  ;  $V_{REF}=V_{BATT}$ ; PGAs disabled;  $OSR=1024$  ;  $Nelconv=8$  ;  $f_s=250kHz$ ; Resolution=16bits.

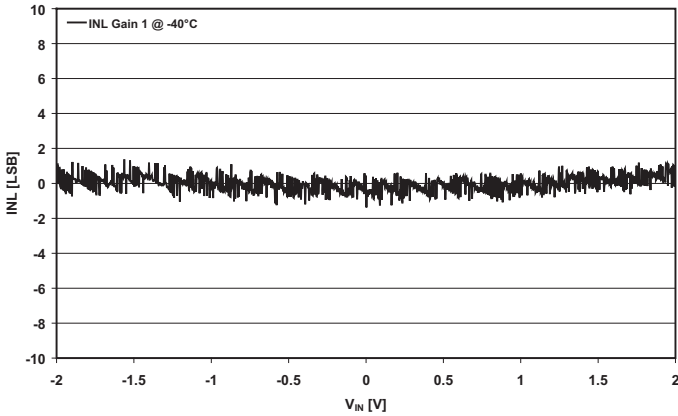

Figure 29. INL -40°C

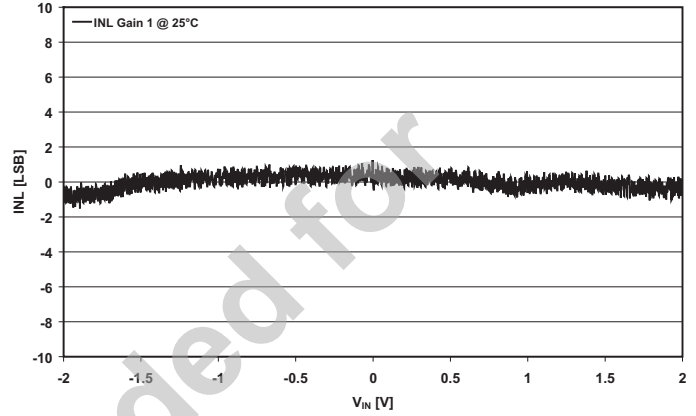

Figure 30. INL 25°C

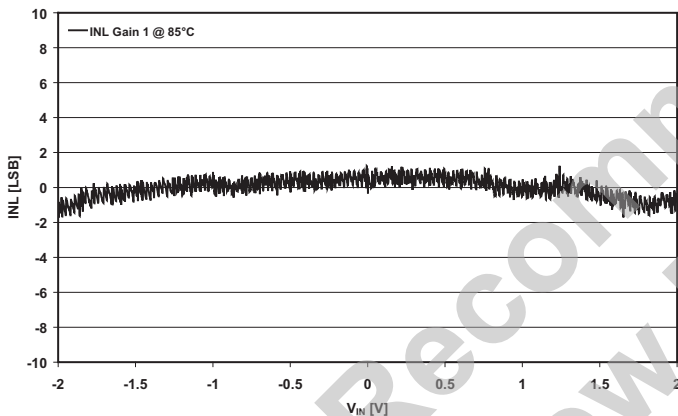

Figure 31. INL 85°C

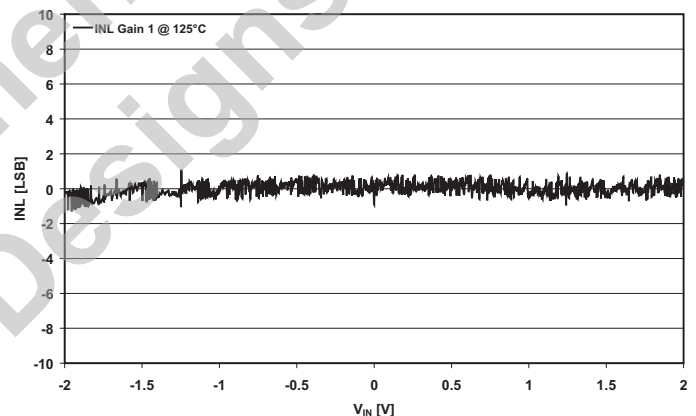

Figure 32. INL 125°C

**11.3.1.2 Gain 10**

$V_{BATT}=5V$  ;  $V_{REF}=V_{BATT}$ ; ADC and PGA3 enabled ;  $GD_3=10$ ;  $OSR=1024$  ;  $Nelconv=8$  ;  $f_s=250kHz$ ; Resolution=16bits.

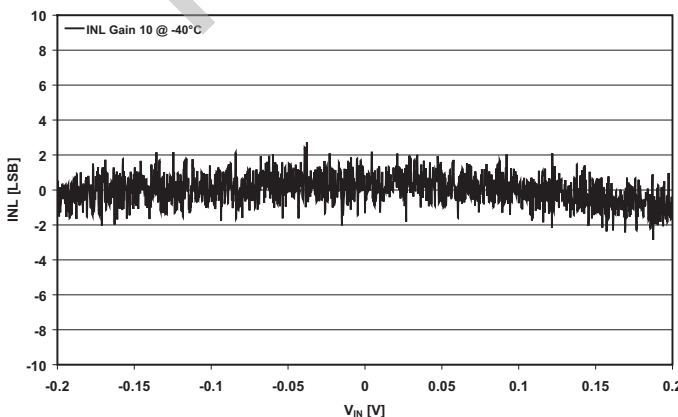

Figure 33. INL -40°C

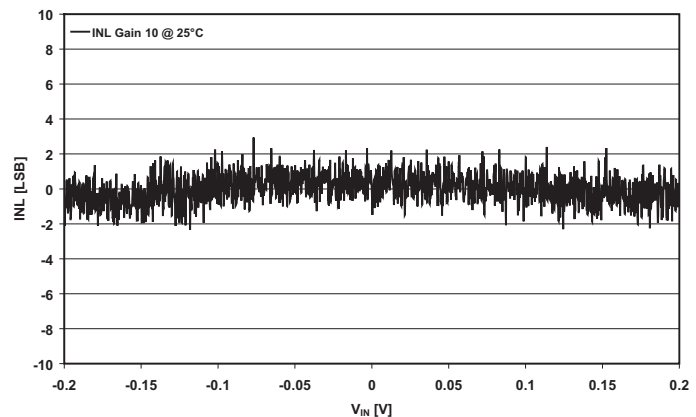

Figure 34. INL 25°C

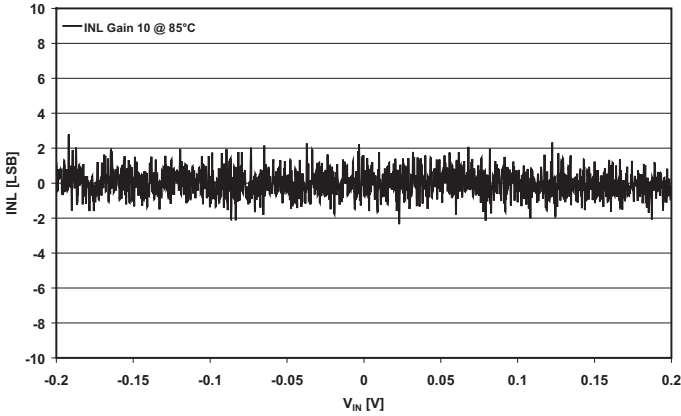

Figure 35. INL 85°C

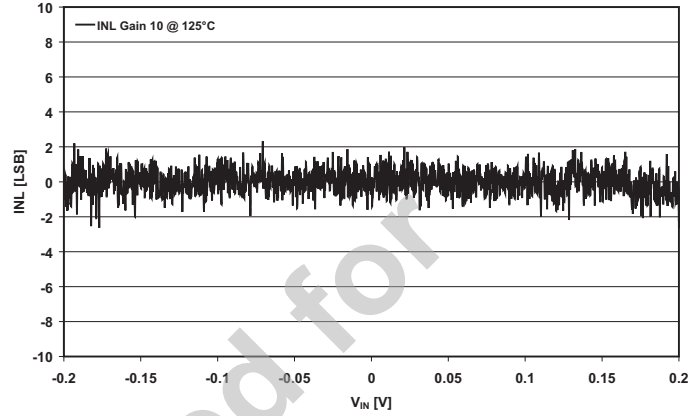

Figure 36. INL 125°C

### 11.3.1.3 Gain 100

VBATT=5V ; VREF=VBATT; ADC, PGA2 and PGA3 enabled ; GD2=10; GD3=10; OSR=1024 ; Nelconv=8 ; fs=250kHz; Resolution=16bits.

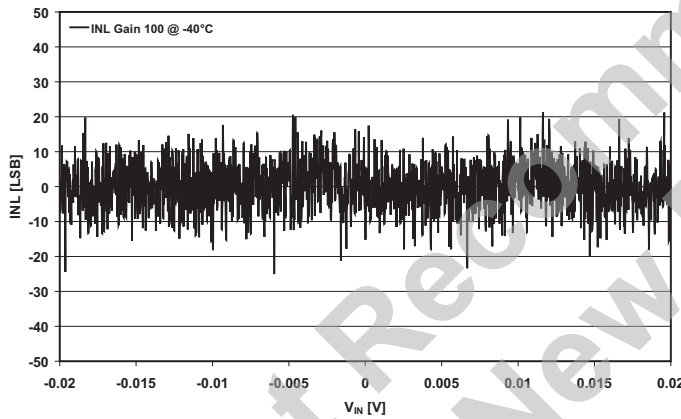

Figure 37. INL -40°C

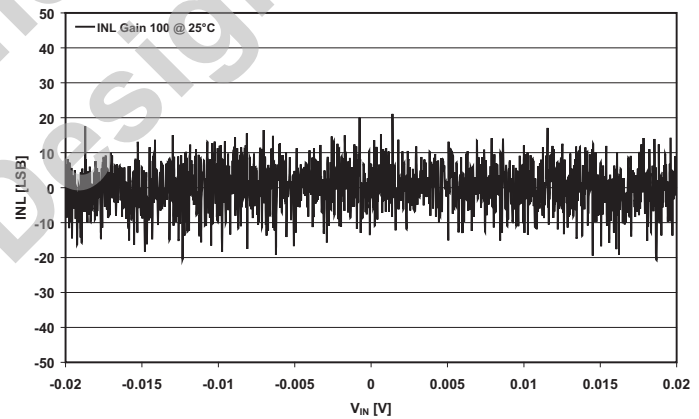

Figure 38. INL 25°C

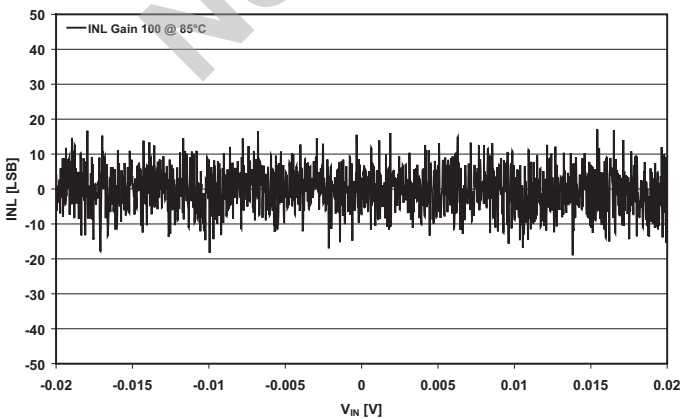

Figure 39. INL 85°C

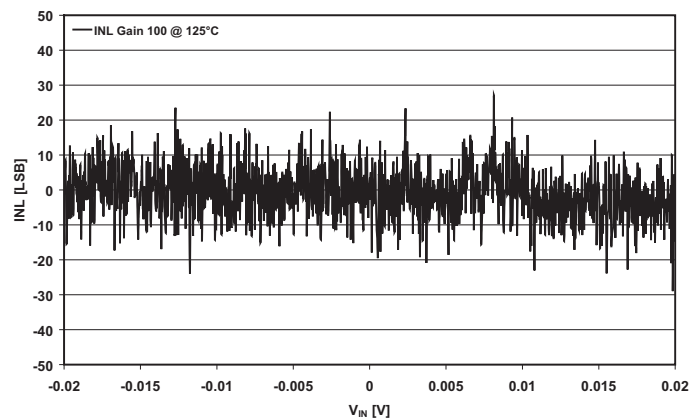

Figure 40. INL 125°C

**11.3.1.4 Gain 1000**

VBATT=5V ; VREF=VBATT; ADC, PGA3, PGA2, PGA1 enabled; GD1=10, GD2=10, GD3=10; OSR=1024 ; NELCONV=8 ; fs=250KHz; Resolution=16bits.

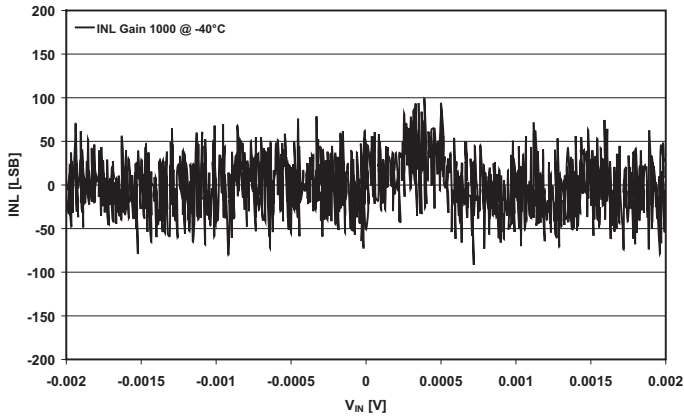

Figure 41. INL -40°C

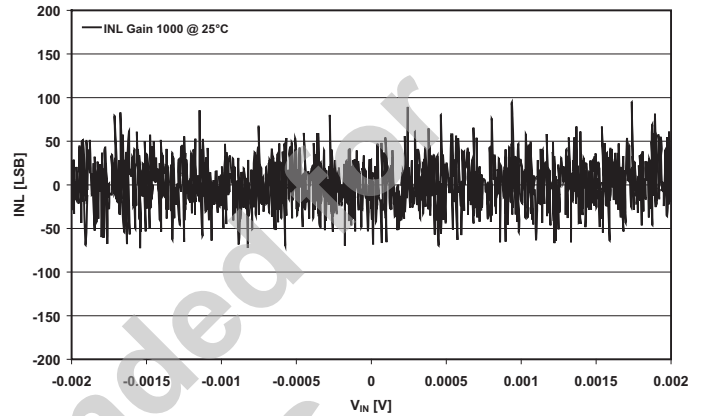

Figure 42. INL 25°C

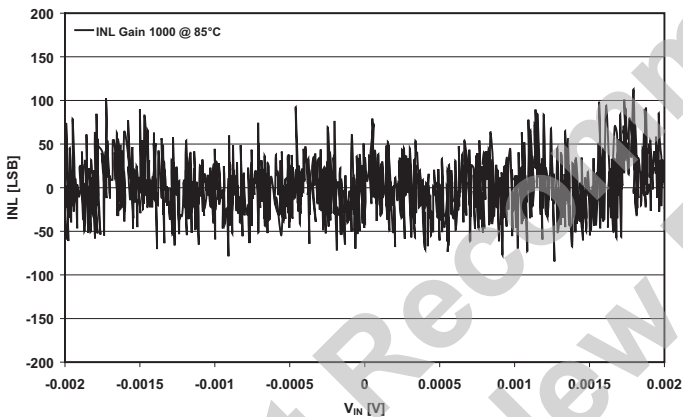

Figure 43. INL 85°C

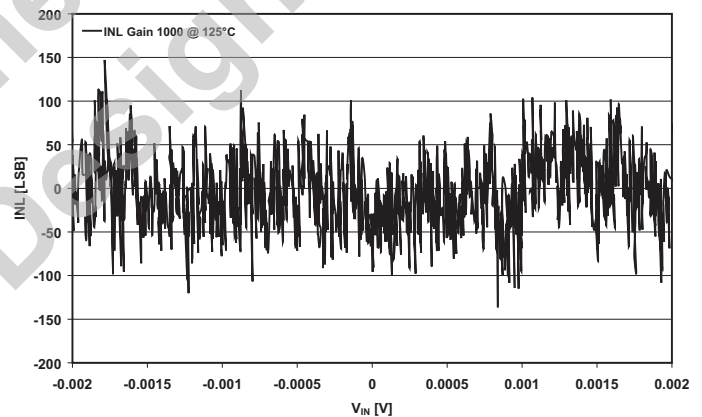

Figure 44. INL 125°C

### 11.3.2 Differential Non-Linearity

The differential non-linearity is generated by the ADC. The PGA does not add differential non-linearity. [Figure 45](#) shows the differential non-linearity.

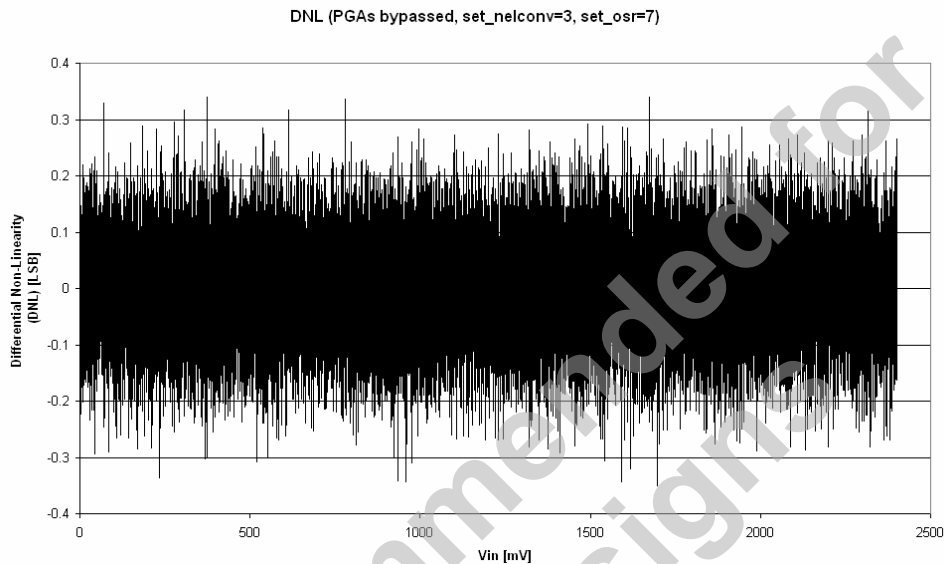

Figure 45. Differential Non-Linearity of the ADC Converter

### 11.4 Noise

Ideally, a constant input voltage  $V_{IN}$  should result in a constant output code. However, because of circuit noise, the output code may vary for a fixed input voltage. Thus, a statistical analysis on the output code of 1200 conversions for a constant input voltage was performed to derive the equivalent noise levels of PGA1, PGA2, and PGA3.

The extracted rms output noise of PGA1, 2, and 3 are given in [Table 39, page 56](#): standard output deviation and output rms noise voltage.

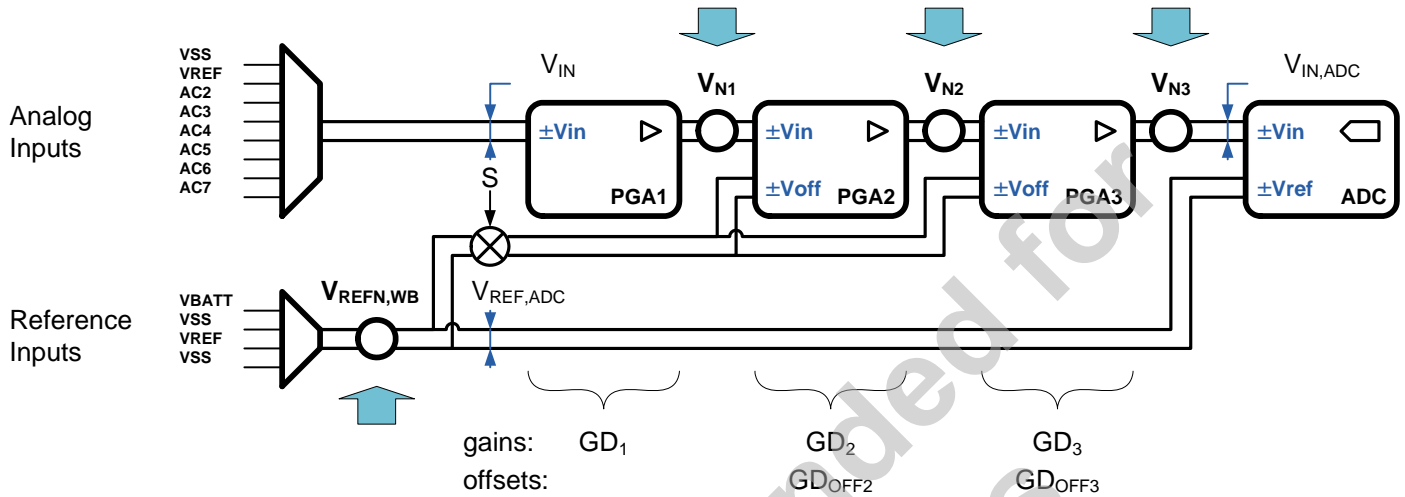

Figure 46. Simple Noise Model for PGAs and ADC

$V_{N1}$ ,  $V_{N2}$ , and  $V_{N3}$  are the output rms noise figures of [Table 39](#),  $GD_1$ ,  $GD_2$ , and  $GD_3$  are the PGA gains of stages 1 to 3 respectively.  $V_{REFN,WB}$  is the wide band noise on the reference voltage.

The simple noise model of [Figure 46](#) is used to estimate the equivalent input referred rms noise  $V_{N,IN}$  of the acquisition chain in the model of [Figure 48](#), [page 56](#). This is given by the relationship:

$$V_{N,IN}^2 = \frac{\left(\frac{V_{N1}}{GD_1}\right)^2 + \left(\frac{V_{N2}}{GD_1 \cdot GD_2}\right)^2 + \left(\frac{V_{N3}}{GD_{TOT}}\right)^2 + \left(\frac{V_{REFN,WB} (GD_2 \cdot GD_{OFF2} + GD_{OFF3})}{GD_{TOT}}\right)^2 + \left(\frac{1}{2} \cdot \frac{V_{REFN,WB}}{GD_{TOT}}\right)^2}{(OSR \cdot N_{ELCONV})} [V^2_{rms}]$$

Equation 28

On the numerator of [Equation 28](#) :

- 1 the first parenthesis is the PGA1 gain amplifier contribution to noise
- 2 the second parenthesis is the PGA2 gain amplifier contribution to noise
- 3 the third parenthesis is the PGA3 gain amplifier contribution to noise
- 4 the fourth parenthesis is PGA2 and PGA3 offset amplifiers contributions to noise
- 5 the last parenthesis is the contribution of the noise on the references of the ADC

As shown in [Equation 28](#), noise can be reduced by increasing  $OSR$  and  $NELCONV$  (increases the ADC averaging effect, but reduces noise).

**Table 39. PGA Noise Measurement (n = 16bits, OSR = 512, NELCONV = 2, VREF = 5V)**

Parameter	PGA1	PGA2	PGA3
Output RMS noise(uV)	$V_{N1} = 205$	$V_{N2} = 340$	$V_{N3} = 365$

[Figure 47](#) shows the distribution for the ADC alone (PGA1, 2, and 3 bypassed). Quantization noise is dominant in this case, and, thus, the ADC thermal noise is below 16 bits.

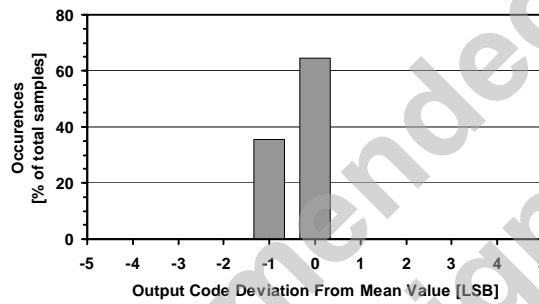

*Figure 47. ADC Noise (PGA1, 2 & 3 Bypassed, OSR = 512, NELCONV = 2)*

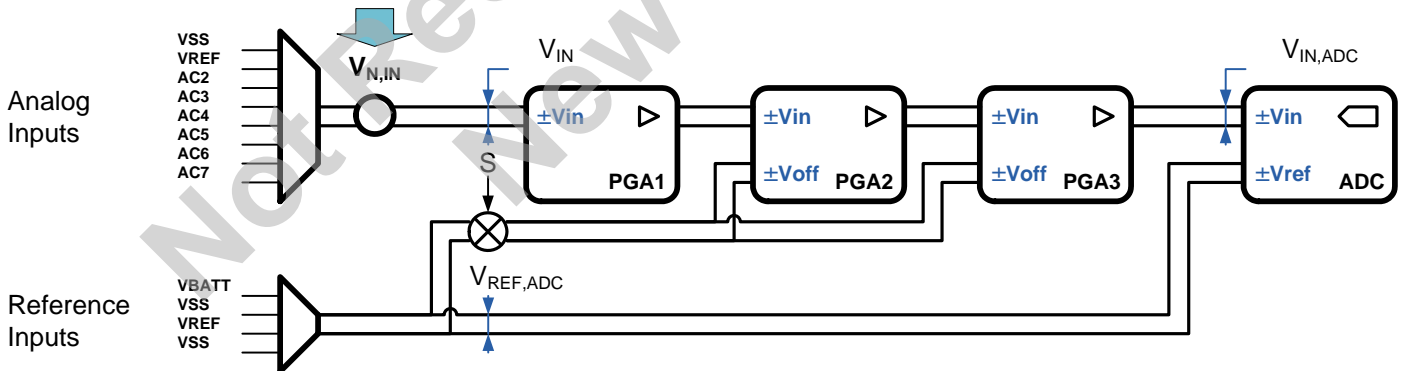

*Figure 48. Total Input Referred Noise*

As an example, consider the system where:  $GD2 = 10$  ( $GD1 = 1$ ; PGA3 bypassed),  $OSR = 512$ ,  $NELCONV = 2$ ,  $VREF = 5$  V. In this case, the noise contribution  $V_{N1}$  of PGA1 is dominant over that of PGA2. Using [Equation 28, page 55](#), we get:  $V_{N,IN} = 6.4 \mu\text{V}$  (rms) at the input of the acquisition chain, or, equivalently, 0.85 LSB at the output of the ADC. Considering 0.2 V (rms) maximum signal amplitude, the signal-to-noise ratio is 90dB.



### 11.5 Gain Error and Offset Error

Gain error is defined as the amount of deviation between the ideal transfer function (theoretical [Equation 19, page 33](#)) and the measured transfer function (with the offset error removed).

The actual gain of the different stages can vary depending on the fabrication tolerances of the different elements. Although these tolerances are specified to a maximum of  $\pm 3\%$ , they will be most of the time around  $\pm 0.5\%$ . Moreover, the tolerances between the different stages are not correlated and the probability to get the maximal error in the same direction in all stages is very low. Finally, these gain errors can be calibrated by the software at the same time with the gain errors of the sensor for instance.

**Figure 49** shows gain error drift vs. temperature for different PGA gains. The curves are expressed in % of Full-Scale Range (FSR) normalized to 25°C.

Offset error is defined as the output code error for a zero volt input (ideally, output code = 0). The offset of the ADC and the PGA1 stage are completely suppressed if  $NELCONV > 1$ .

The measured offset drift vs. temperature curves for different PGA gains are depicted in **Figure 50**. The output offset error, expressed in LSB for 16-bit setting, is normalized to 25°C. Notice that if the ADC is used alone, the output offset error is below  $\pm 1$  LSB and has no drift.

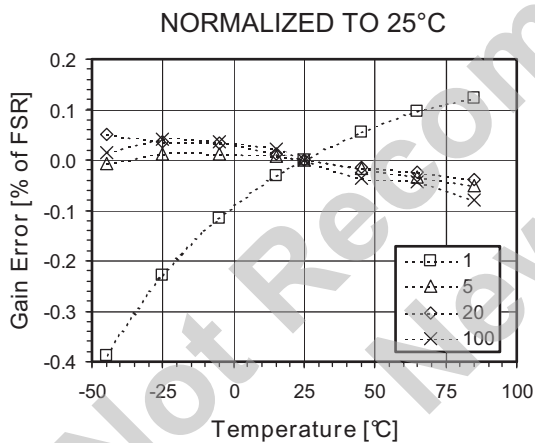

Figure 49. Gain Error vs. Temperature for Different Gains

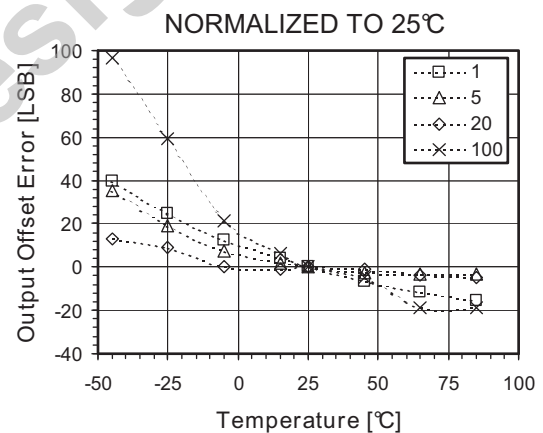

Figure 50. Offset Error vs. Temperature for Different Gains

**11.6 Power Consumption**

**Figure 51** plots the variation of current consumption with supply voltage  $V_{BATT}$ , as well as the distribution between the 3 PGA stages and the ADC (see **Table 40, page 60**). The Charge Pump is forced ON for  $V_{BATT} < 4.2V$  and forced OFF for  $V_{BATT} > 4.2V$ .

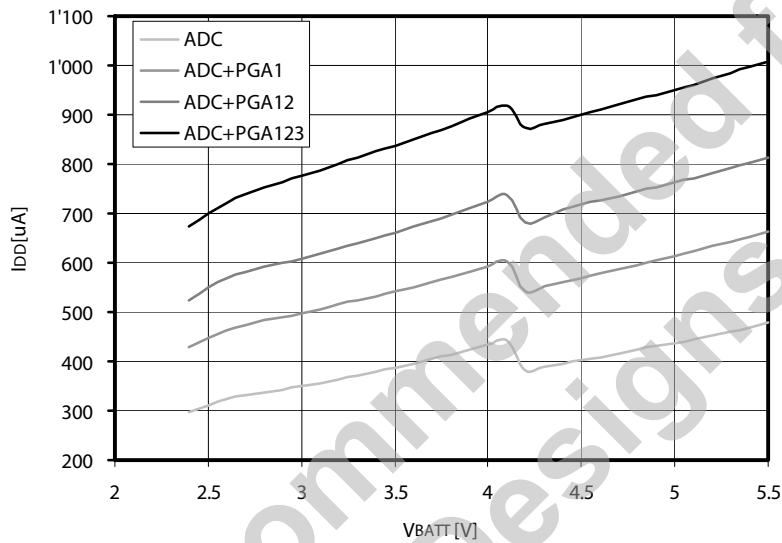

Figure 51. Current Consumption vs. Supply Voltage and PGAs

As shown in **Figure 52**, if lower sampling frequency is used, the current consumption can be lowered by reducing the bias currents of the PGAs and the ADC with registers *IbAmpPga* and *IbAmpAdc*. (In **Figure 52**, *IbAmpPga/Adc* = '11', '10', '00' for  $f_s = 500, 250, 62.5$  kHz respectively. The Charge Pump is forced ON for  $V_{BATT} < 4.2V$  and forced OFF for  $V_{BATT} > 4.2V$ ).

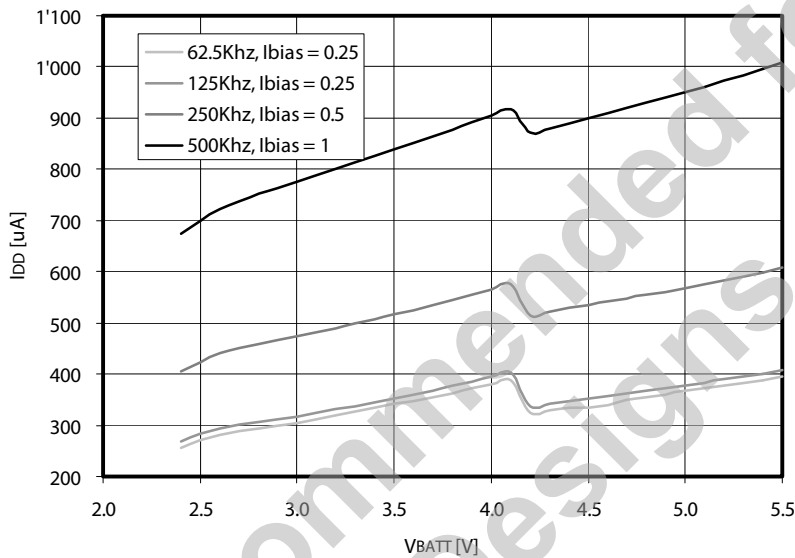

Figure 52. Current Consumption vs Temperature and ADC Sampling Frequency

Current consumption vs. temperature is depicted in [Figure 53](#), showing the increase between -40 and +125°C.

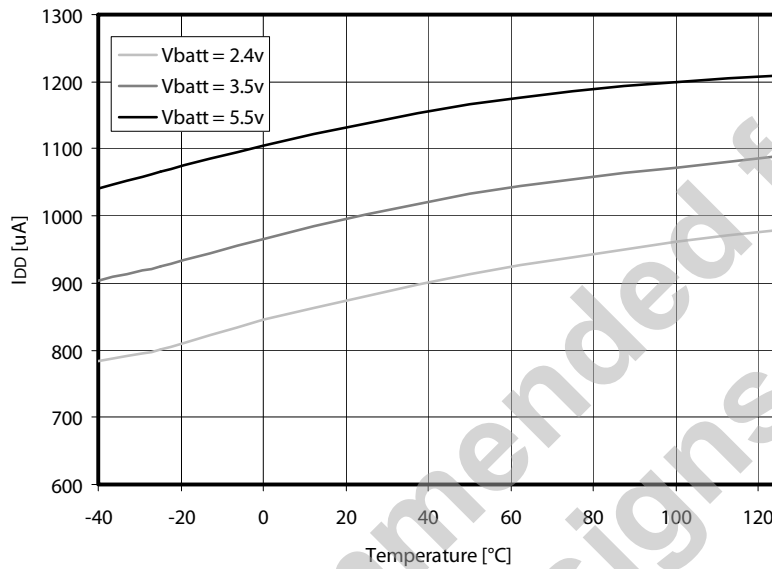

Figure 53. Current Consumption vs Temperature and Supply Voltage

**Table 40. Typical Current Distribution in Acquisition Chain (n = 16 bits, fs = 250kHz)**

Supply	ADC	PGA1	PGA2	PGA3	Total	Unit
VBATT = 2.4V	207	70	51	78	406	uA
VBATT = 3.5V	282	82	61	91	516	
VBATT = 5.5V	338	103	67	98	606	

## FAMILY OVERVIEW

This chapter gives an overview of similar devices based on the ZoomingADC but with different features or packages. Each part is described in it's own datasheet.

## 12 Comparizon table

**Table 41. Family comparizon table**

		Part number					
		SX8723C	SX8724C	SX8725C	SX8723S	SX8724S	SX8725S
<b>Package</b>		MLPD-W-12 4x4	MLPQ-16 4x4	MLPD-W-12 4x4	MLPQ-16 4x4	MLPQ-16 4x4	MLPQ-16 4x4
<b>Protocol</b>		I2C	I2C	I2C	SPI	SPI	SPI
<b>GPIO</b>	<b>D0</b>	I2C addr, Digital IO or Vref OUT	I2C addr, Digital IO or Vref OUT	I2C addr, Digital IO or Vref OUT	Digital IO or Vref OUT	Digital IO or Vref OUT	Digital IO or Vref OUT
	<b>D1</b>	I2C addr, Digital IO or Vref IN	I2C addr, Digital IO or Vref IN	I2C addr, Digital IO or Vref IN	Digital IO or Vref OUT.	Digital IO or Vref IN	Digital IO or Vref IN
	<b>D2</b>	N.A.	Digital IO	N.A.	N.A.	N.A.	N.A.
	<b>D3</b>	N.A.	Digital IO	N.A.	N.A.	N.A.	N.A.
<b>Differential input channels</b>		2	3	1	2	3	1

**13 Comparizon by package pinout**

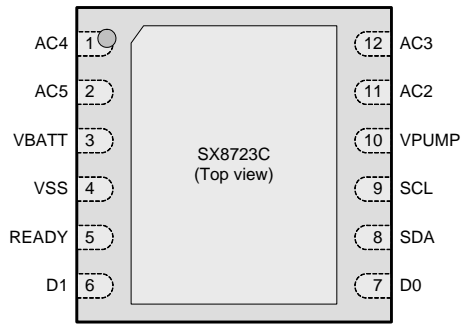
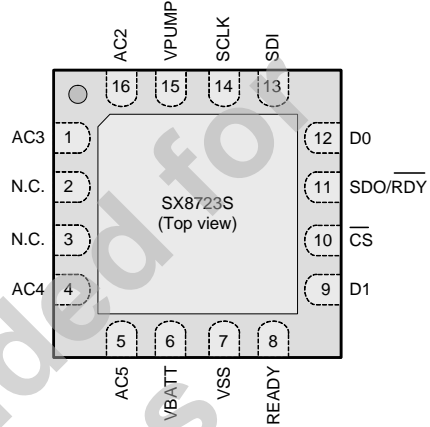
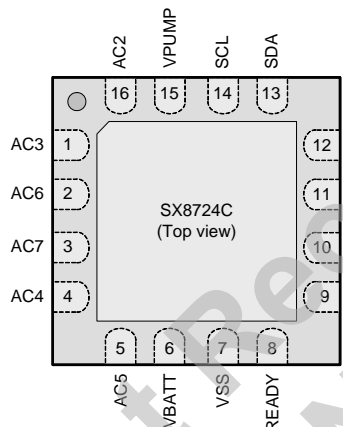
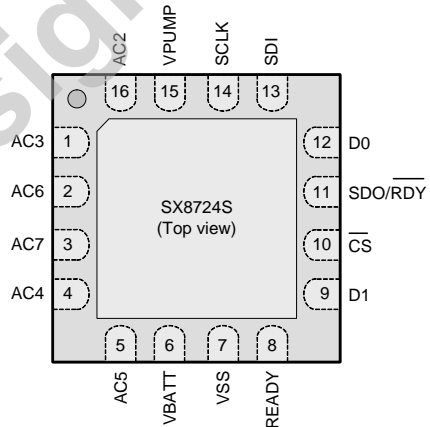
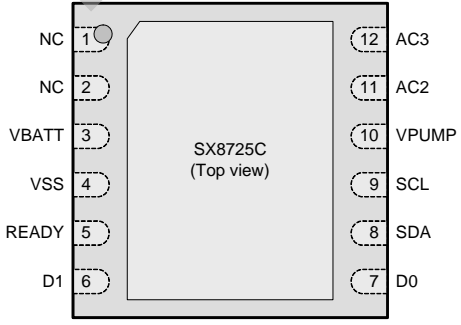
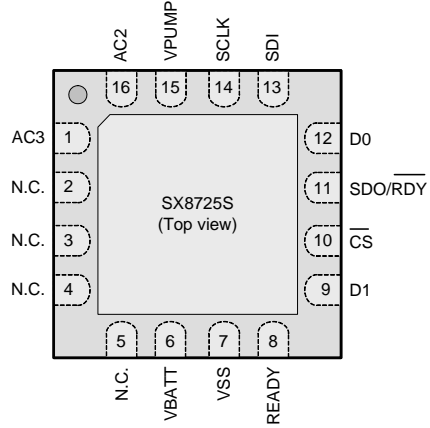
I2C versions	SPI versions
 <p>SX8723C (Top view)</p>	 <p>SX8723S (Top view)</p>
 <p>SX8724C (Top view)</p>	 <p>SX8724S (Top view)</p>
 <p>SX8725C (Top view)</p>	 <p>SX8725S (Top view)</p>

## MECHANICAL

---

### 14 PCB Layout Considerations

PCB layout considerations to be taken when using the SX8724C are relatively simple to get the highest performances out of the ZoomingADC. The most important to achieve good performances out the ZoomingADC is to have a good voltage reference. The SX8724C has already an internal reference that is good enough to get the best performances with a minimal amount of external components, but, in case an external reference is needed this one must be as clean as possible in order to get the desired performance. Separating the digital from the analog lines will be also a good choice to reduce the noise induced by the digital lines. It is also advised to have separated ground planes for digital and analog signals with the shortest return path, as well as making the power supply lines as wider as possible and to have good decoupling capacitors.

### 15 How to Evaluate

For evaluation purposes SX8724CEVK evaluation kit can be ordered. This kit connects to any PC using a USB port. The "SX87xx Evaluation Tools" software gives the user the ability to control the SX8724C registers as well as getting the raw data from the ZoomingADC and displaying it on the "Graphical User interface". For more information please look at SEMTECH web site (<http://www.semtech.com>).

Not Recommended for New Designers

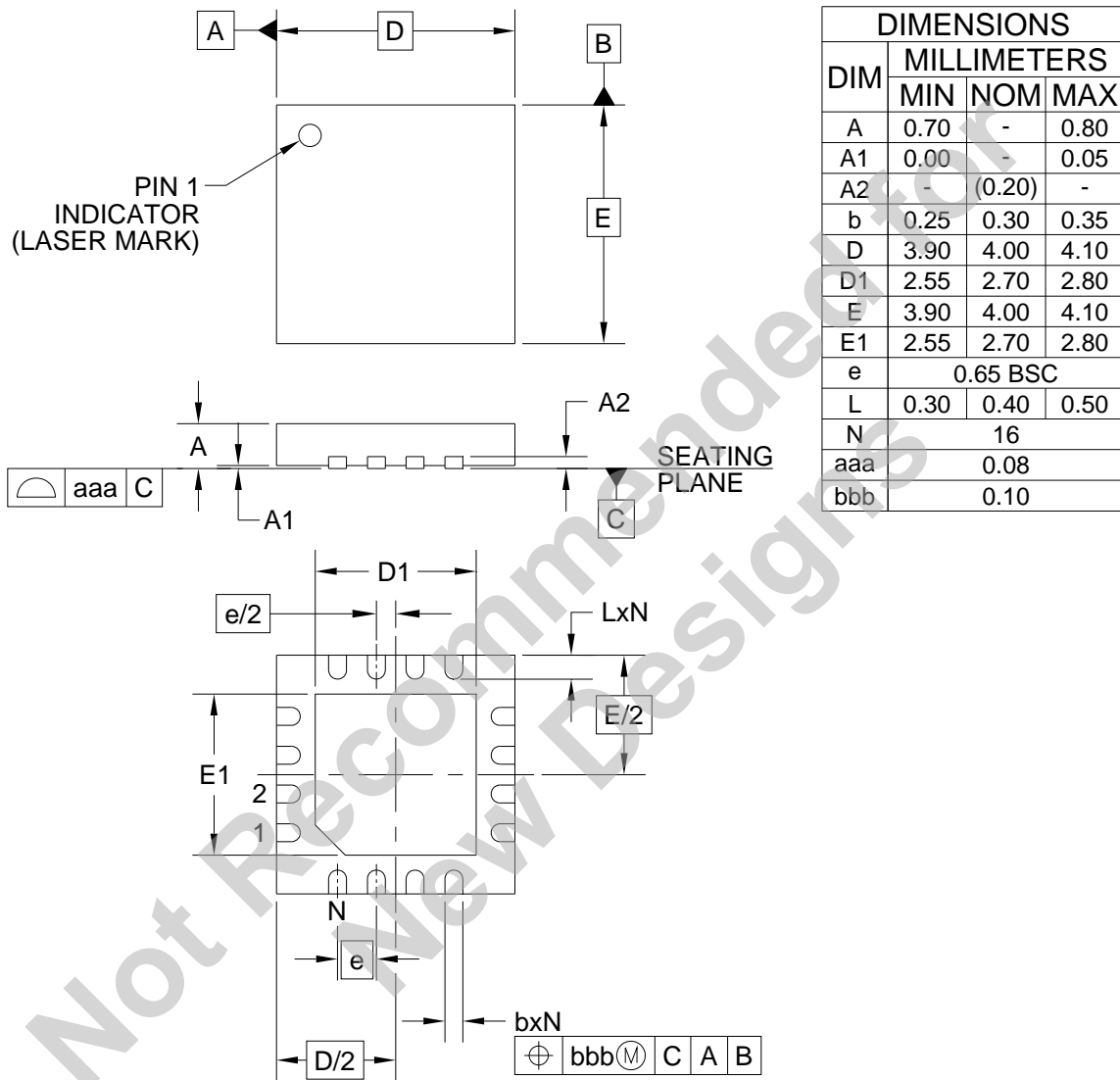
**16 Package Outline Drawing: MLPQ-W16-4x4-EP1**

**NOTES:**

1. CONTROLLING DIMENSIONS ARE IN MILLIMETERS (ANGLES IN DEGREES).
2. COPLANARITY APPLIES TO THE EXPOSED PAD AS WELL AS THE TERMINALS.

*Figure 54. Package Outline Drawing*

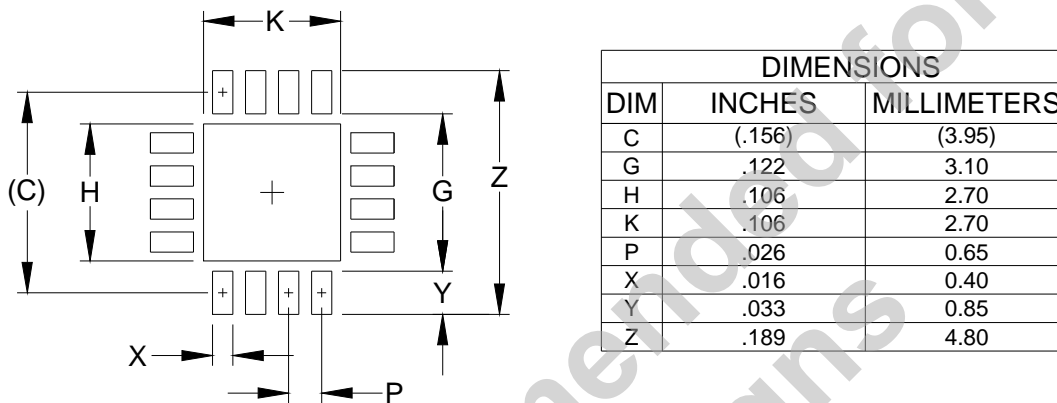

**17 Land Pattern Drawing: 4x4MLPQ-W16-EP1**

**NOTES:**

1. CONTROLLING DIMENSIONS ARE IN MILLIMETERS (ANGLES IN DEGREES).
2. THIS LAND PATTERN IS FOR REFERENCE PURPOSES ONLY. CONSULT YOUR MANUFACTURING GROUP TO ENSURE YOUR COMPANY'S MANUFACTURING GUIDELINES ARE MET.
3. THERMAL VIAS IN THE LAND PATTERN OF THE EXPOSED PAD SHALL BE CONNECTED TO A SYSTEM GROUND PLANE. FAILURE TO DO SO MAY COMPROMISE THE THERMAL AND/OR FUNCTIONAL PERFORMANCE OF THE DEVICE.
4. SQUARE PACKAGE - DIMENSIONS APPLY IN BOTH " X " AND " Y " DIRECTIONS.

*Figure 55. Land Pattern Drawing*

## 18 Tape and Reel Specification

MLP/QFN (0.70mm - 1.00mm package thickness)

- Single Sprocket holes
- Tolerances for  $A_o$  &  $B_o$  are  $\pm 0.20\text{mm}$
- Tolerances for  $K_o$  is  $\pm 0.10\text{mm}$
- Tolerance for Pocket Pitch is  $\pm 0.10\text{mm}$
- Tolerance for Tape width is  $\pm 0.30\text{mm}$
- Trailer and Leader Length are minimum required length
- Package Orientation and Feed Direction

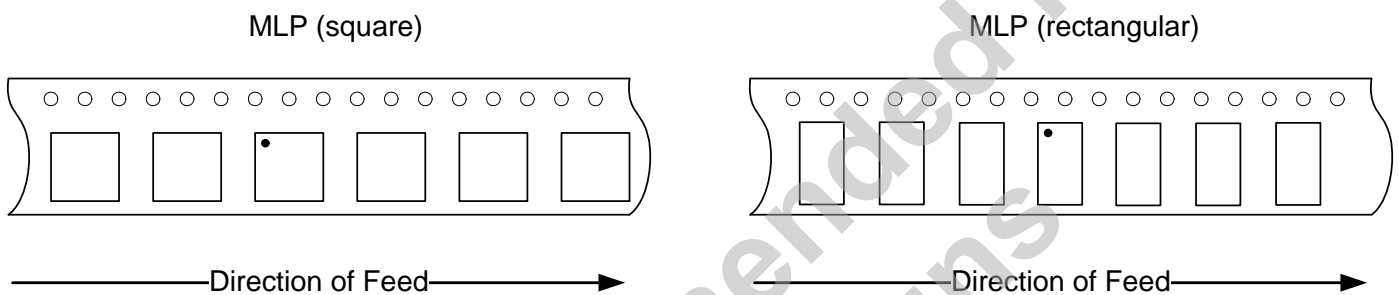

Figure 56. Direction of Feed

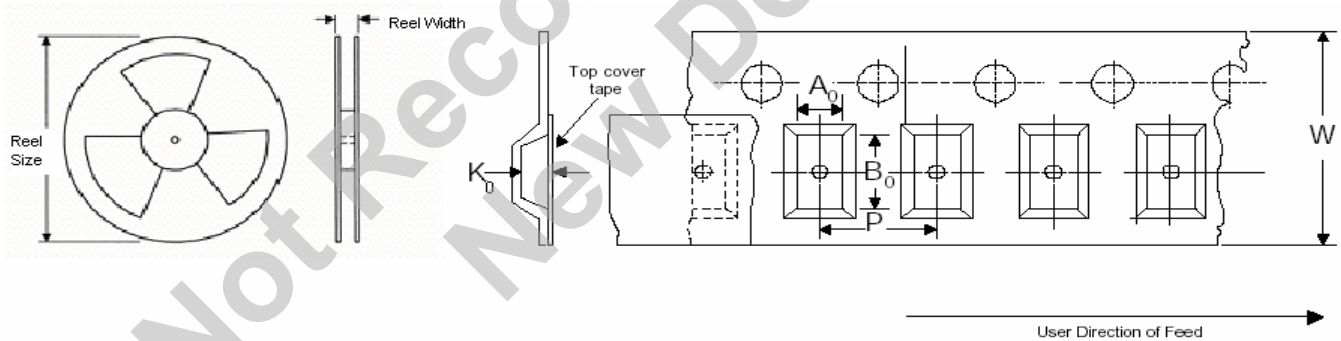

Figure 57. User direction of feed

**Table 42. Tape and reel specifications**

Pkg size	carrier tape (mm)					Reel		Trailer Length (mm)	Leader Length (mm)	QTY per Reel
	Tape Width (W)	Pocket Pitch (P)	$A_o$	$B_o$	$K_o$	Reel Size (in)	Reel Width (mm)			
4x4	12	8	4.35	4.35	1.10	7/13	12.4	400	400	1000/3000

© Semtech 2010

All rights reserved. Reproduction in whole or in part is prohibited without the prior written consent of the copyright owner. The information presented in this document does not form part of any quotation or contract, is believed to be accurate and reliable and may be changed without notice. No liability will be accepted by the publisher for any consequence of its use. Publication thereof does not convey nor imply any license under patent or other industrial or intellectual property rights. Semtech assumes no responsibility or liability whatsoever for any failure or unexpected operation resulting from misuse, neglect improper installation, repair or improper handling or unusual physical or electrical stress including, but not limited to, exposure to parameters beyond the specified maximum ratings or operation outside the specified range.

SEMTECH PRODUCTS ARE NOT DESIGNED, INTENDED, AUTHORIZED OR WARRANTED TO BE SUITABLE FOR USE IN LIFE-SUPPORT APPLICATIONS, DEVICES OR SYSTEMS OR OTHER CRITICAL APPLICATIONS. INCLUSION OF SEMTECH PRODUCTS IN SUCH APPLICATIONS IS UNDERSTOOD TO BE UNDERTAKEN SOLELY AT THE CUSTOMER'S OWN RISK. Should a customer purchase or use Semtech products for any such unauthorized application, the customer shall indemnify and hold Semtech and its officers, employees, subsidiaries, affiliates, and distributors harmless against all claims, costs damages and attorney fees which could arise.

Notice: All referenced brands, product names, service names and trademarks are the property of their respective owners.

#### Contact information

#### Semtech Corporation Advanced Communications & Sensing Products

E-mail: [sales@semtech.com](mailto:sales@semtech.com) or [acsupport@semtech.com](mailto:acsupport@semtech.com)  
Internet: <http://www.semtech.com>

#### USA

200 Flynn Road, Camarillo, CA 93012-8790.  
Tel: +1 805 498 2111 Fax: +1 805 498 3804

#### FAR EAST

12F, No. 89 Sec. 5, Nanking E. Road, Taipei, 105, TWN, R.O.C.  
Tel: +886 2 2748 3380 Fax: +886 2 2748 3390

#### EUROPE

Semtech Ltd., Units 2 & 3, Park Court, Premier Way, Abbey Park Industrial Estate, Romsey, Hampshire, SO51 9DN.  
Tel: +44 (0)1794 527 600 Fax: +44 (0)1794 527 601

## X-ON Electronics

Largest Supplier of Electrical and Electronic Components

*Click to view similar products for [Sensor Interface](#) category:*

*Click to view products by [Semtech](#) manufacturer:*

Other Similar products are found below :

[ZSC31150GEG1-T](#) [ZSSC4161BE2W](#) [MCZ33784EF](#) [FM-254-8-P](#) [LM1815MX/NOPB](#) [FM-213-4-P](#) [MAX31850KATB+](#) [FM-215-8](#) [FM-253-4-P](#) [AS8510-ASSM](#) [AD598AD](#) [AD598JRZ](#) [AD598SD/883B](#) [743478D](#) [AD698APZ](#) [AD698SQ](#) [ADA4558WHCPZ-R7](#) [ADPD4000BCBZR7](#) [ADPD4001BCBZR7](#) [DRV401AIDWPR](#) [MAX9921AUB/V+T](#) [MAX1358BETL+](#) [MAX14827ATG+](#) [MAX14832ETB+](#) [MAX14829ATG+](#) [MAX14838GTC+T](#) [MAX22520GWP+](#) [MAX31911AUI+](#) [RE46C803SS20](#) [MAX14826GTG+](#) [MAX1452AAE+](#) [MAX31855SASA+T](#) [MAX31855EASA+](#) [MAX31855SASA+](#) [MAX31855TASA+](#) [MAX31855KASA+T](#) [MAX31855NASA+](#) [MAX35102ETJ+](#) [MAX35103EHJ+](#) [MAX6682MUA+](#) [MAX86171ENI+](#) [MAX9921AUB+](#) [MAX9924UAUB+T](#) [MAX9925AUB+](#) [MAX9927AEE+](#) [MAX1454AUE/V+](#) [MAX1454AUE+](#) [RE46C800SS20](#) [SSC7102-GQ-AB2](#) [MAX6675ISA+](#)