

WIRELESS & SENSING

GENERAL DESCRIPTION

The SX9300 is the world's first dual channel capacitive Specific Absorption Rate (SAR) controller that accurately discriminates between an inanimate object and human body proximity. The resulting detection is used in portable electronic devices to reduce and control radio-frequency (RF) emission power in the presence of a human body, enabling significant performance advantages for manufacturers of electronic devices with electro-magnetic radiation sources to meet stringent emission regulations' criteria and Specific Absorption Rate (SAR) standards. Operating directly from an input supply voltage of 2.7 to 5.5V, the SX9300 outputs its data via a 1.65 – 5.5V host compatible I2C serial bus.

The I2C serial communication bus port is compatible with 1.8V host control to report body detection/proximity and to facilitate parameter settings adjustment. Upon proximity detection, the NIRQ output asserts, enabling the user to either determine the relative proximity distance, or simply obtain an indication of detection.

The SX9300 includes an on-chip auto-calibration controller that regularly performs sensitivity adjustments to maintain peak performance over a wide variation of temperature, humidity and noise environments, providing simplified product development and enhanced performance. A dedicated transmit enable (TXEN) pin is available to synchronize proximity measurements to RF transmission, enabling very low supply current and high noise immunity by only measuring proximity when requested.

KEY PRODUCT FEATURES

- ◆ **2.7 – 5.5V Input Supply Voltage**
- ◆ **Dual SAR Capacitive Sensor Inputs**
 - ❖ On-Chip SAR Engine For Body versus Inanimate Object Detection
 - ❖ Down to 0.08 fF Capacitance Resolution
 - ❖ Stable Proximity Sensing With Temperature
 - ❖ 20mm detection distance
 - ❖ Capacitance Offset Compensation up to 30pF
- ◆ **Active Sensor Guarding**
- ◆ **Automatic Calibration**
- ◆ **Ultra Low Power Consumption:**
 - ❖ Active Mode: 170 uA
 - ❖ Doze Mode: 18 uA
 - ❖ Sleep Mode: 2.5 uA
- ◆ **400kHz I2C Serial Interface**
 - ❖ Four programmable I2C Sub-Addresses
 - ❖ Input Levels Compatible with 1.8V Host Processors
- ◆ **Open Drain NIRQ Interrupt pin**
- ◆ **Three (3) Reset Sources: POR, NRST pin, Soft Reset**
- ◆ **-40°C to +85°C Operation**
- ◆ **Compact Size: 3 x 3mm Thin QFN package**
- ◆ **Pb & Halogen Free, RoHS/WEEE compliant**

APPLICATIONS

- SAR Compliant Systems
- Notebooks
- Tablets
- Mobile Phones
- Mobile Hot Spots

ORDERING INFORMATION

Part Number	Package	Marking
SX9300IULTRT ¹	QFN-20	ZM5C
SX9300EVKA	Eval. Kit	-

¹ 3000 Units/reel

TYPICAL APPLICATION CIRCUIT

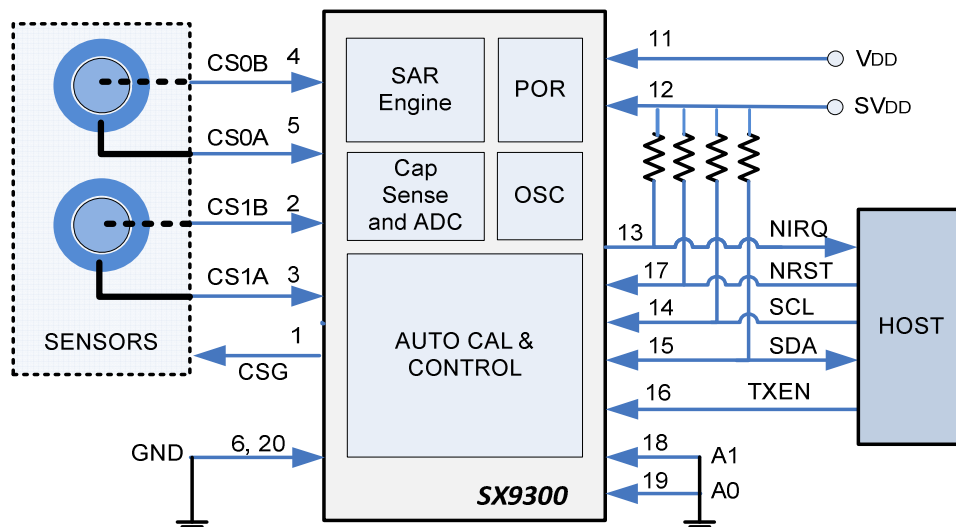
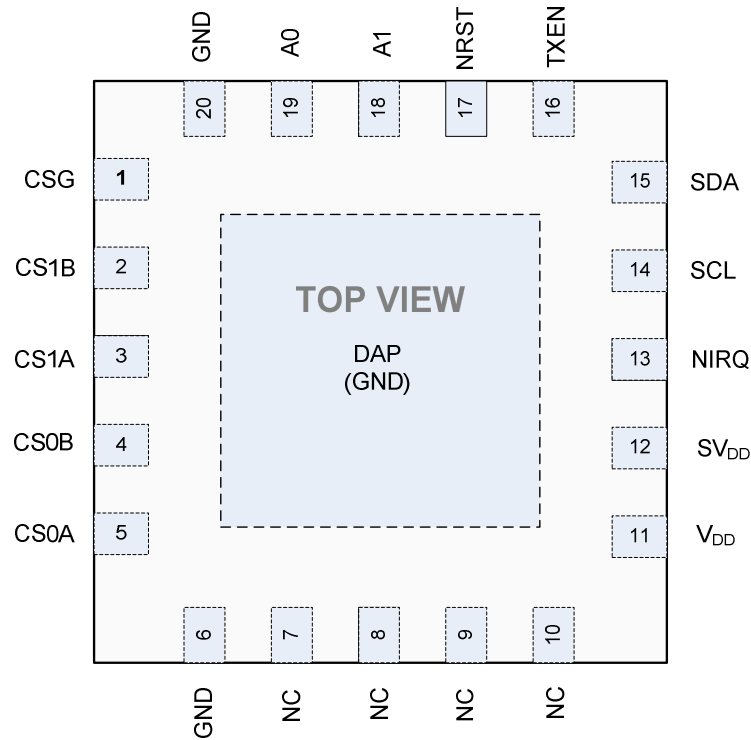
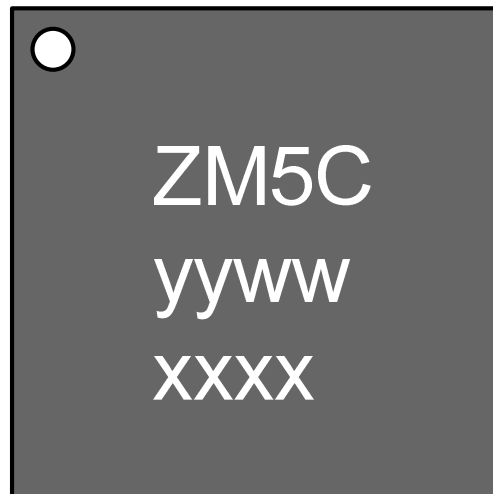

Table of Contents

GENERAL DESCRIPTION.....	1
KEY PRODUCT FEATURES.....	1
APPLICATIONS.....	1
ORDERING INFORMATION.....	1
TYPICAL APPLICATION CIRCUIT	1
1 GENERAL DESCRIPTION.....	4
1.1 Pin Diagram	4
1.2 Marking Information	4
1.3 Pin Description	5
1.4 Acronyms	5
2 ELECTRICAL CHARACTERISTICS	6
2.1 Absolute Maximum Ratings	6
2.2 Operating Conditions	6
2.3 Thermal Characteristics	6
2.4 Electrical Specifications	7
3 PROXIMITY SENSING INTERFACE.....	9
3.1 Introduction	9
3.2 Scan Period	9
3.3 Analog Front-End (AFE)	10
3.3.1 Capacitive Sensing Basics	10
3.3.2 AFE Block Diagram	12
3.3.3 Capacitance-to-Voltage Conversion (C-to-V)	12
3.3.4 Shield Control	12
3.3.5 Offset Compensation	12
3.3.6 Analog-to-Digital Conversion (ADC)	13
3.4 Digital Processing	13
3.4.1 Overview	13
3.4.2 PROXRW Update	15
3.4.3 PROXUSEFUL Update	15
3.4.4 PROXAVG Update	16
3.4.5 PROXDIFF Update	18
3.4.6 PROXSTAT Update	18
3.5 Host Operation	19
3.6 Operational Modes	20
3.6.1 Active	20
3.6.2 Doze	20
3.6.3 Sleep	20
3.6.4 TXEN Pin	20
4 SMART SAR ENGINE	21
4.1 Introduction	21
4.2 Sensor Design	21
4.3 Processing	22
5 I2C INTERFACE.....	23
5.1 Introduction	23
5.2 I2C Write	23
5.3 I2C Read	23
6 RESET.....	25

WIRELESS & SENSING

6.1	Power-up	25
6.2	NRST Pin	25
6.3	Software Reset	26
7	INTERRUPT	27
7.1	Power-up	27
7.2	Assertion and Clearing	27
8	PINS DESCRIPTION	28
8.1	V _{DD} and SV _{DD}	28
8.2	TXEN	28
8.3	Capacitive Sensing Interface (CS0A, CS0B, CS1A, CS1B, CSG)	28
8.4	Host Interface	28
8.4.1	NIRQ	28
8.4.2	SCL, NRST and TXEN	29
8.4.3	SDA	29
9	REGISTERS	30
9.1	Overview	30
9.2	Detailed Description	31
10	APPLICATION INFORMATION	36
10.1	Typical Application Circuit	36
10.2	External Components Recommended Values	36
11	PACKAGING INFORMATION	37
11.1	Outline Drawing	37
11.2	Land Pattern	38

WIRELESS & SENSING
1 GENERAL DESCRIPTION
1.1 Pin Diagram

Figure 1: Pin Diagram
1.2 Marking Information

yyww = Date Code
 xxxx = Lot Number

Figure 2: Marking Information

1.3 Pin Description

Number	Name	Type	Description
1	CSG	Analog	Capacitive Sensor Guard/Shield
2	CS1B	Analog	Capacitive Sensor B (inner) of pair 1
3	CS1A	Analog	Capacitive Sensor A (outer) of pair 1
4	CS0B	Analog	Capacitive Sensor B (inner) of pair 0
5	CS0A	Analog	Capacitive Sensor A (outer) of pair 0
6	GND	Ground	Ground
7	NC	Not Used	Do Not Connect
8	NC	Not Used	Do Not Connect
9	NC	Not Used	Do Not Connect
10	NC	Not Used	Do Not Connect
11	V _{DD}	Power	Core power supply
12	SV _{DD}	Power	Host interface power supply. Must be ≤V _{DD} at all times (including during power-up and power-down)
13	NIRQ	Digital Output	Interrupt request, active LOW, requires pull-up resistor to SV _{DD}
14	SCL	Digital Input	I2C Clock, requires pull-up resistor to SV _{DD}
15	SDA	Digital I/O	I2C Data, requires pull-up resistor to SV _{DD}
16	TXEN	Digital Input	Transmit Enable, active HIGH (Tie to SV _{DD} if not used).
17	NRST	Digital Input	External reset, active LOW (Tie to SV _{DD} if not used).
18	A1	Digital Input	I2C Sub-Address, connect to GND or V _{DD}
19	A0	Digital Input	I2C Sub-Address, connect to GND or V _{DD}
20	GND	Ground	Ground
DAP	GND	Ground	Exposed Pad. Connect to Ground

Table 1: Pin Description

1.4 Acronyms

DAP	Die Attach Paddle
SAR	Specific Absorption Rate
RF	Radio Frequency

2 ELECTRICAL CHARACTERISTICS

2.1 Absolute Maximum Ratings

Stresses above the values listed in “Absolute Maximum Ratings” may cause permanent damage to the device. This is a stress rating only and functional operation of the device at these, or any other conditions beyond the “Operating Conditions”, is not implied. Exposure to Absolute Maximum Rating conditions for extended periods may affect device reliability and proper functionality.

Parameter	Symbol	Min	Max	Unit
Supply Voltage	V _{DD}	-0.5	6.0	V
	SV _{DD}	-0.5	6.0	
Input Voltage (non-supply pins)	V _{IN}	-0.5	V _{DD} +0.3	
Input Current (non-supply pins)	I _{IN}	-10	10	mA
Operating Junction Temperature	T _{JCT}	-40	125	°C
Reflow Temperature	T _{RE}	-	260	
Storage Temperature	T _{STOR}	-50	150	
ESD HBM (Human Body model, to JESD22-A114)	ESD _{HBM}	8	-	kV

Table 2: Absolute Maximum Ratings

2.2 Operating Conditions

Parameter	Symbol	Min	Max	Unit
Supply Voltage	V _{DD}	2.7	5.5	V
	SV _{DD}	1.65	V _{DD}	
Ambient Temperature	T _A	-40	85	°C

Table 3: Operating Conditions

Note: During power-up or power-down, SV_{DD} must be less than or equal to V_{DD}

2.3 Thermal Characteristics

Parameter	Symbol	Typical	Unit
Thermal Resistance – Junction to Air (Static Airflow)	θ _{JA}	34	°C/W

Table 4: Thermal Characteristics

Note: θ_{JA} is calculated from a package in still air, mounted to 3" x 4.5", 4-layer FR4 PCB with thermal vias under exposed pad per JESD51 standards.

WIRELESS & SENSING
2.4 Electrical Specifications

All values are valid within the operating conditions unless otherwise specified.

Typical values are given for $T_A = +25^\circ\text{C}$, $V_{DD} = SV_{DD} = 3.3\text{V}$ unless otherwise specified.

Parameter	Symbol	Conditions	Min	Typ	Max	Unit
Current Consumption						
Sleep (no sensor enabled)	I_{SLEEP}	Power down, all analog circuits shut down. (I2C listening)	-	2.5	-	uA
Doze (all sensors enabled)	I_{DOZE}	SCANPERIOD = 200ms DOZEPERIOD = 2xSCANPERIOD FREQ = 167kHz RESOLUTION = Medium VDD = 5V	-	18	-	
Active (all sensors enabled)	I_{ACTIVE}	SCANPERIOD = 30ms FREQ = 167kHz RESOLUTION = Medium VDD = 5V	-	170	-	
Outputs: SDA, NIRQ						
Output Current at Output Low Voltage	I_{OL}	VOL = 0.4V	6	-	-	mA
Maximum Output LOW Voltage	$V_{\text{OL(Max)}}$	$SV_{\text{DD}} > 2\text{V}$	-	-	0.4	V
		$SV_{\text{DD}} \leq 2\text{V}$	-	-	$0.2 \times SV_{\text{DD}}$	
Inputs: SCL, SDA, TXEN						
Input logic high	V_{IH}		$0.8 \times SV_{\text{DD}}$	-	$SV_{\text{DD}} + 0.3$	V
Input logic low	V_{IL}		-0.3	-	$0.25 \times SV_{\text{DD}}$	
Input leakage current	I_{L}	CMOS input	-1	-	1	uA
Hysteresis	V_{HYS}	$SV_{\text{DD}} > 2\text{V}$	-	$0.05 \times SV_{\text{DD}}$	-	V
		$SV_{\text{DD}} \leq 2\text{V}$	-	$0.1 \times SV_{\text{DD}}$	-	
TXEN Delay	$\text{TXEN}_{\text{ACTDLY}}$	Delay between TXEN rising edge and SX9300 starting measurements	-	100	-	μs
Inputs: A0, A1						
Input logic high	V_{IH}		$0.7 \times V_{\text{DD}}$	-	$V_{\text{DD}} + 0.3$	V
Input logic low	V_{IL}		-0.3	-	$0.3 \times V_{\text{DD}}$	
Input: NRST						
Input logic high	V_{IH}	$SV_{\text{DD}} > 2\text{V}$	$0.7 \times SV_{\text{DD}}$	-	$SV_{\text{DD}} + 0.3$	V
		$SV_{\text{DD}} \leq 2\text{V}$	$0.75 \times SV_{\text{DD}}$	-		
Input logic low	V_{IL}	$SV_{\text{DD}} > 2\text{V}$	-	-	0.6	
		$SV_{\text{DD}} \leq 2\text{V}$	-	-	$0.3 \times SV_{\text{DD}}$	
NRST minimum pulse width	T_{RESETPW}		2	-	-	μs
Start-up						
Power-up time	T_{POR}		-	1	-	ms

Table 5: Electrical Specifications

WIRELESS & SENSING

Parameter	Symbol	Conditions	Min	Typ	Max	Unit
I2C Timing Specifications (Cf. Figure 3 and Figure 4 below)						
SCL clock frequency	f_{SCL}		-	-	400	kHz
SCL low period	t_{LOW}		1.3	-	-	us
SCL high period	t_{HIGH}		0.6	-	-	
Data setup time	$t_{SU;DAT}$		0.1	-	-	
Data hold time	$t_{HD;DAT}$		0	-	-	
Repeated start setup time	$t_{SU;STA}$		0.6	-	-	
Start condition hold time	$t_{HD;STA}$		0.6	-	-	
Stop condition setup time	$t_{SU;STO}$		0.6	-	-	
Bus free time between stop and start	t_{BUF}		1.3	-	-	
Input glitch suppression	t_{SP}	Note 1	-	-	50	

Note 1: Minimum glitch amplitude is $0.7V_{DD}$ at High level and Maximum $0.3V_{DD}$ at Low level.

Table 6: I2C Timing Specifications

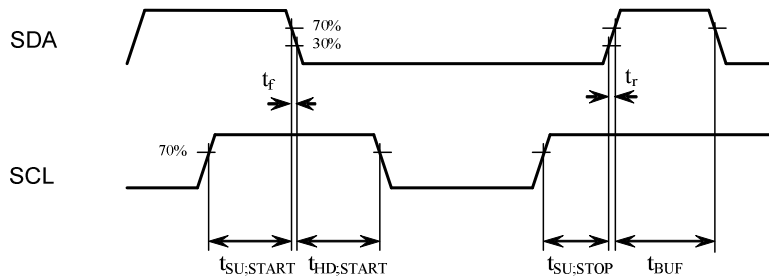

Figure 3: I2C Start and Stop Timing

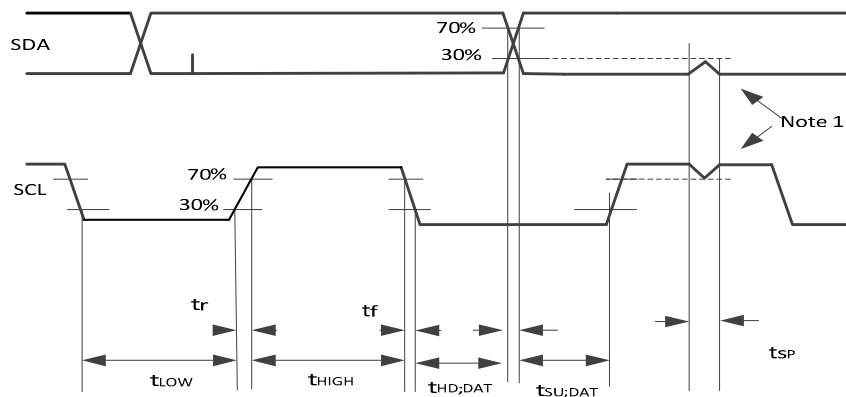

Figure 4: I2C Data Timing

3 PROXIMITY SENSING INTERFACE

3.1 Introduction

The purpose of the proximity sensing interface is to detect when a conductive object (usually a body part i.e. finger, palm, face, etc) is in the proximity of the system. Note that proximity sensing can be done thru the air or thru a solid (typically plastic) overlay (also called “touch” sensing).

The chip’s proximity sensing interface is based on capacitive sensing technology. An overview is given in figure below.

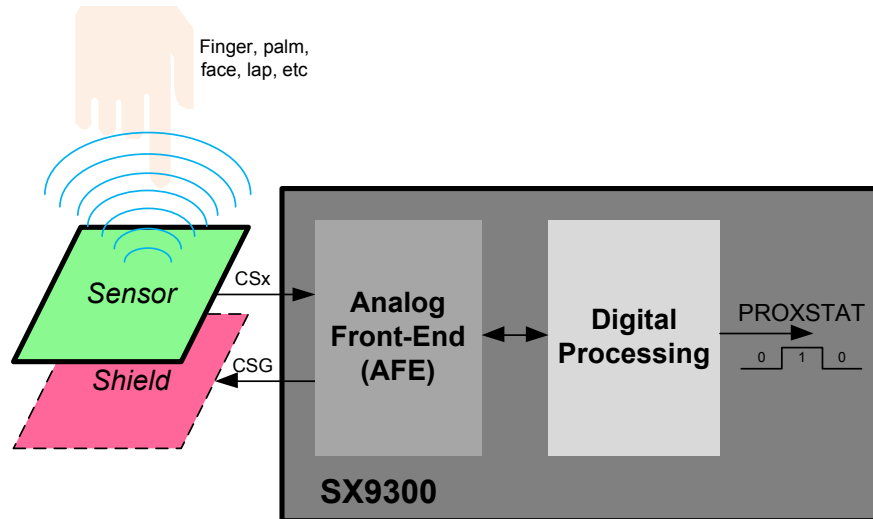

Figure 5: Proximity Sensing Interface Overview

- ❖ The sensor can be a simple copper area on a PCB or FPC for example. Its capacitance (to ground) will vary when a conductive object is moving in its proximity.
- ❖ The optional shield can be also be a simple copper area on a PCB or FPC below/under/around the sensor. It is used to protect the sensor against potential surrounding noise sources and improve its global performance. It also brings directivity to the sensing, for example sensing objects approaching from top only.
- ❖ The analog front-end (AFE) performs the raw sensor’s capacitance measurement and converts it into a digital value. It also controls the shield. See §3.3 for more details.
- ❖ The digital processing block computes the raw capacitance measurement from the AFE and extracts a binary information PROXSTAT corresponding to the proximity status, i.e. object is “Far” or “Close”. It also triggers AFE operations (compensation, etc). See §3.4 for more details.

3.2 Scan Period

To save power and since the proximity event is slow by nature, the chip will be waken-up regularly at every programmed scan period (SCANPERIOD) to first sense sequentially each of the enabled CSx pins and then process new proximity samples/info. The chip will be in idle mode most of the time. This is illustrated in figure below

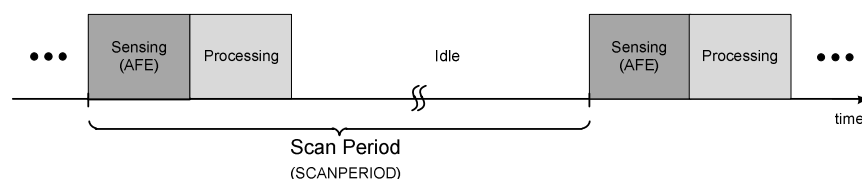

Figure 6: Proximity Sensing Sequencing

WIRELESS & SENSING

The sensing and processing phase's durations vary with the number of sensors enabled, the sampling frequency, and the resolution programmed. During the Idle phase, the SX9300's analog circuits are turned off. Upon expiry of the idle timer, a new scan period cycle begins.

The scan period determines the minimum reaction time (actual/final reaction time also depends on debounce and filtering settings) and can be programmed from 30ms to 400ms.

3.3 Analog Front-End (AFE)

3.3.1 Capacitive Sensing Basics

Capacitive sensing is the art of measuring a small variation of capacitance in a noisy environment. As mentioned above, the chip's proximity sensing interface is based on capacitive sensing technology. In order to illustrate some of the user choices and compromises required when using this technology it is useful to understand its basic principles.

To illustrate the principle of capacitive sensing we will use the simplest implementation where the sensor is a copper plate on a PCB.

The figure below shows a cross-section and top view of a typical capacitive sensing implementation. The sensor connected to the chip is a simple copper area on top layer of the PCB. It is usually surrounded (shielded) by ground for noise immunity (shield function) but also indirectly couples via the grounds areas of the rest of the system (PCB ground traces/planes, housing, etc). For obvious reasons (design, isolation, robustness ...) the sensor is stacked behind an overlay which is usually integrated in the housing of the complete system.

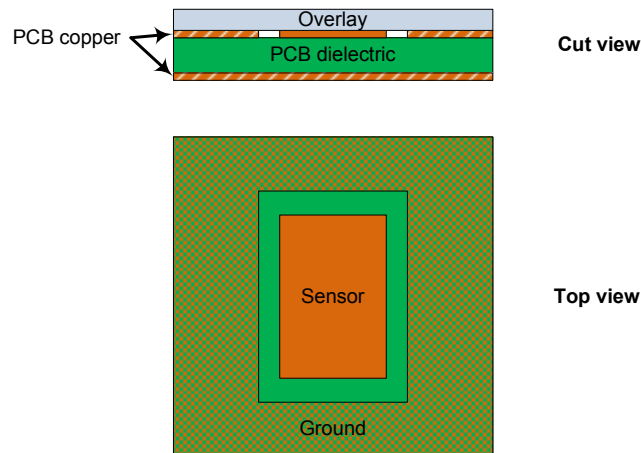

Figure 7: Typical Capacitive Sensing Implementation

When the conductive object to be detected (finger/palm/face, etc) is not present, the sensor only sees an inherent capacitance value C_{Env} created by its electrical field's interaction with the environment, in particular with ground areas.

When the conductive object (finger/palm/face, etc) approaches, the electrical field around the sensor will be modified and the total capacitance seen by the sensor increased by the user capacitance C_{User} . This phenomenon is illustrated in the figure below.

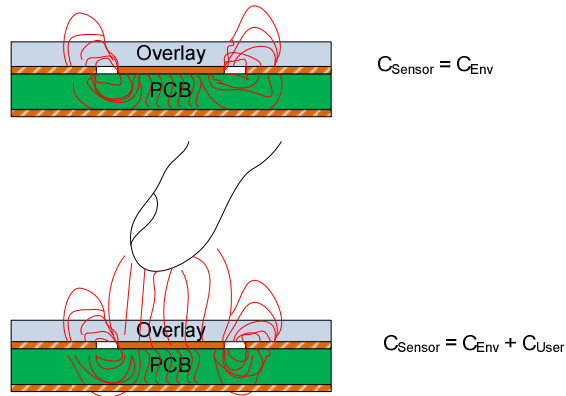

Figure 8: Proximity Effect on Electrical Field and Sensor Capacitance

The challenge of capacitive sensing is to detect this relatively small variation of C_{Sensor} (C_{User} usually contributes for a few percent only) and differentiate it from environmental noise (C_{Env} also slowly varies together with the environment characteristics like temperature, etc). For this purpose, the chip integrates an auto offset compensation mechanism which dynamically monitors and removes the C_{Env} component to extract and process C_{User} only. See §3.3.5 for more details.

In first order, C_{User} can be estimated by the formula below:

$$C_{\text{User}} = \frac{\epsilon_0 \cdot \epsilon_r \cdot A}{d}$$

A is the common area between the two electrodes hence the common area between the user's finger/palm/face and the sensor.

d is the distance between the two electrodes hence the proximity distance between the user and the system.

ϵ_0 is the free space permittivity and is equal to $8.85 \cdot 10^{-12}$ F/m (constant)

ϵ_r is the dielectric relative permittivity.

Typical permittivity of some common materials is given in the table below.

Material	Typical ϵ_r
Glass	8
FR4	5
Acrylic Glass	3
Wood	2
Air	1

Table 7: Typical Permittivity of Some Common Materials

From the discussions above we can conclude that the most robust and efficient design will be the one that minimizes C_{Env} value and variations while improving C_{User} .

WIRELESS & SENSING
3.3.2 AFE Block Diagram

Figure 9: Analog Front-End Block Diagram

3.3.3 Capacitance-to-Voltage Conversion (C-to-V)

The sensitivity of the interface is defined by RANGE and GAIN parameters.

PROXFREQ defines the operating frequency of the interface and should be set as high as possible for power consumption reasons.

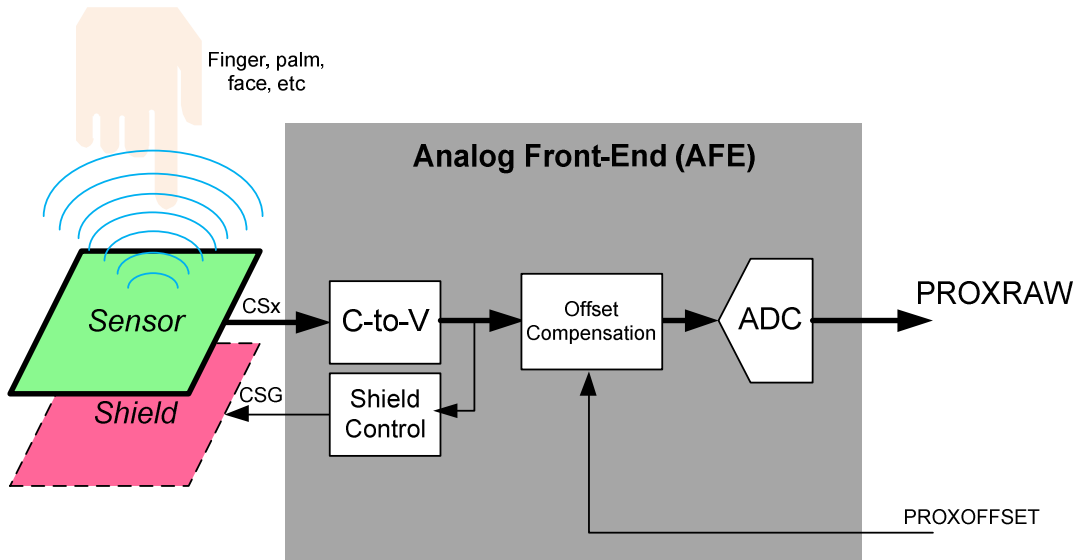
3.3.4 Shield Control

SHIELDEN allows enabling or disabling the shield function.

3.3.5 Offset Compensation

Offset compensation consists in performing a one-time measurement of C_{Env} and subtracting it to the total capacitance C_{Sensor} in order to feed the ADC with the closest contribution of C_{User} only.

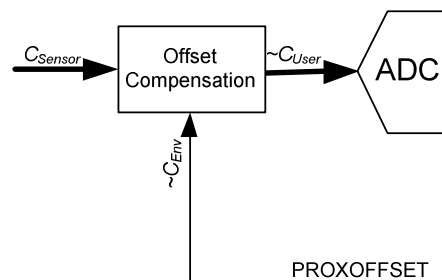

Figure 10: Offset Compensation Block Diagram

The ADC input C_{User} is the total capacitance C_{Sensor} to which C_{Env} is subtracted.

WIRELESS & SENSING

There are five possible compensation sources which are illustrated in the figure below. When set to 1 by any of these sources, COMPSTAT will only be reset once the compensation is completed.

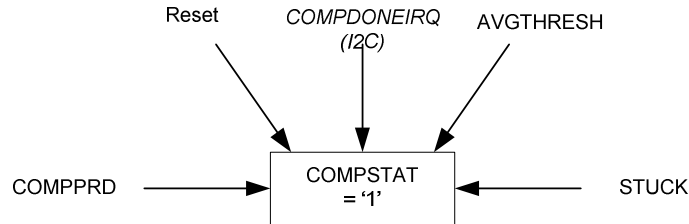

Figure 11: Compensation Request Sources

- **Reset:** a compensation for all sensors is automatically requested when a reset is performed (power-up, NRST pin, RegReset)
- **COMPDONEIRQ (I2C):** a compensation for all sensors can be manually requested anytime by the host through I2C interface by writing a 1 into COMPDONEIRQ.
- **AVGTHRESH:** a compensation for all sensors or only the affected one (depending on COMPMETHOD) can be automatically requested if it is detected that C_{Env} has drifted beyond a predefined range programmed by the host.
- **COMPPRD:** a compensation can be automatically requested at a predefined rate programmed by the host.
- **STUCK:** a compensation can be automatically requested if it is detected that the proximity “Close” state lasts longer than a predefined duration programmed by the host.

Please note that the compensation request flag can be set anytime but the compensation itself is always done at the beginning of a scan period to keep all parameters coherent. Also, when compensation occurs, all PROXSTAT flags turn OFF (ie no proximity detected) independently from the user’s potential actual presence.

3.3.6 Analog-to-Digital Conversion (ADC)

An ADC is used to convert the analog capacitance information into a digital word PROXRAW.

3.4 Digital Processing

3.4.1 Overview

The main purpose of the digital processing block is to convert the raw capacitance information coming from the AFE (PROXRAW) into a robust and reliable digital flag (PROXSTAT) indicating if something is close to the proximity sensor.

The offset compensation performed in the AFE is a one-time measurement. However, the environment capacitance C_{Env} may vary with time (temperature, nearby objects, etc). Hence, in order to get the best estimation of C_{User} (PROXDIFF) it is needed to dynamically track and subtract C_{Env} variations. This is performed by filtering PROXUSEFUL to extract its slow variations (PROXAVG).

PROXDIFF is then compared to user programmable threshold (PROXTHRESH) to extract PROXSTAT flag.

WIRELESS & SENSING

Figure 12: Digital Processing Block Diagram

Digital processing sequencing is illustrated in figure below. At every scan period wake-up, the block updates sequentially PROXRRAW, PROXUSEFUL, PROXAVG, PROXDIFF and PROXSTAT before going back to Idle mode.

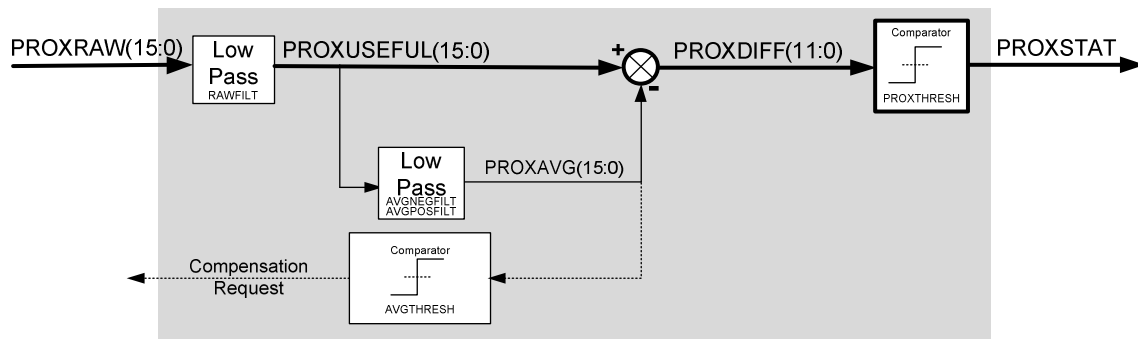
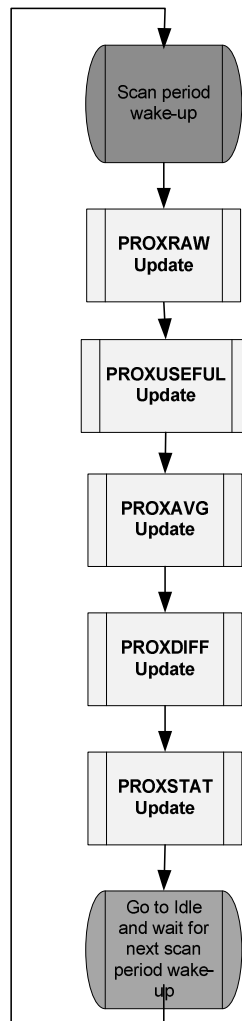

Figure 13: Digital Processing Sequencing

Digital processing block also updates COMPSTAT (set when compensation is currently pending execution or completion)

WIRELESS & SENSING
3.4.2 PROXRAW Update

PROXRAW update consists mainly in starting the AFE and waiting for the new PROXRAW values (one for each CSx/sensor pin) to be ready. If compensation was pending it is performed first.

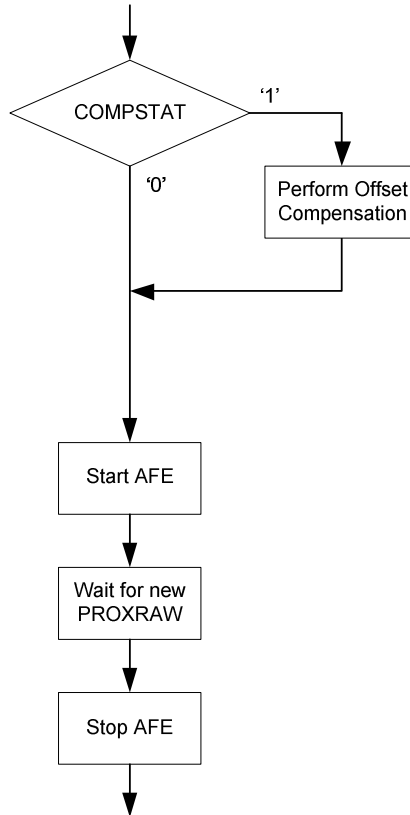

Figure 14: ProxRaw Update

Note that PROXRAW is not available in the “Sensor Data Readback” section of the registers. If needed it can be observed by setting RAWFILT=00 and reading PROXUSEFUL.

3.4.3 PROXUSEFUL Update

PROXUSEFUL update consists in filtering PROXRAW upfront to remove its potential high frequencies components(system noise, interferer, etc) and extract only user activity (few Hz max) and slow environment changes.

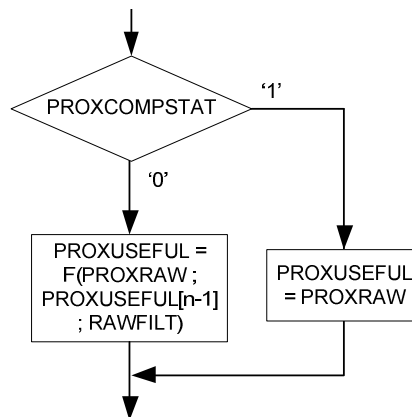

Figure 15: PROXUSEFUL Update

3.4.4 PROXAVG Update

PROXAVG update consists in averaging PROXUSEFUL to ignore its “fast” variations (i.e. user finger/palm/hand) and extract only the very slow variations of environment capacitance C_{Env} .

One can program a debounced threshold (AVGTHRESH/AVGDEB) to define a range within which PROXAVG can vary without triggering compensation (i.e. small acceptable environment drift).

Large positive values of PROXUSEFUL are considered as normal (user finger/hand/head) but large negative values are considered abnormal and should be compensated quickly. For this purpose, the averaging filter coefficient can be set independently for positive and negative variations via AVGPOSFILT and AVGNIEGFILT. Typically we have $AVGPOSFILT > AVGNIEGFILT$ to filter out (abnormal) negative events faster.

To prevent PROXAVG to be “corrupted” by user activity (should only reflect environmental changes) it is frozen when proximity is detected.

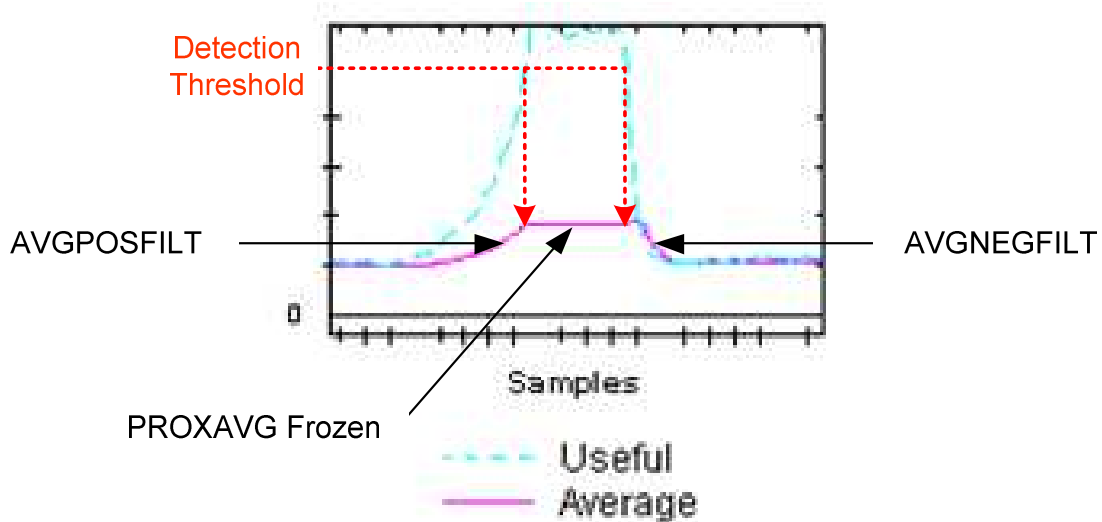
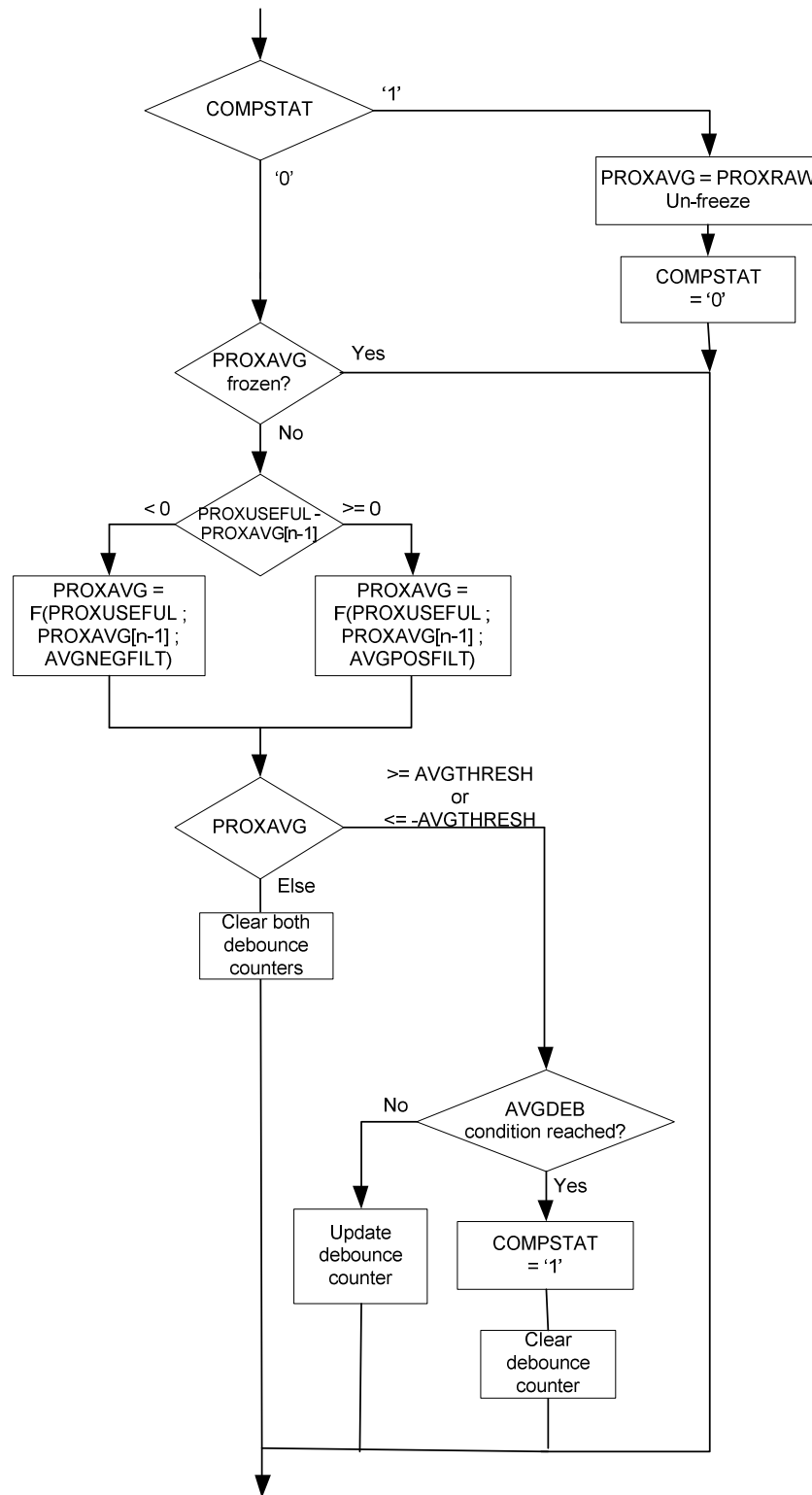
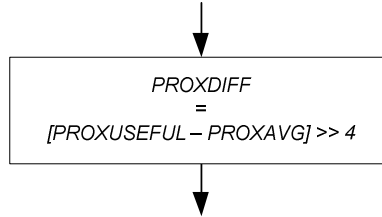

Figure 16: ProxAvg vs Proximity Event

Figure 17: ProxAvg Update

WIRELESS & SENSING
3.4.5 PROXDIF Update

PROXDIF update consists in the complementary operation i.e. subtracting PROXAVG to PROXUSEFUL to ignore slow capacitances variations (C_{Env}) and extract only the user related variations i.e. C_{User} .

Figure 18: ProxDiff Update

Note that only the 12 upper bits of [PROXUSEFUL – PROXAVG] are kept for PROXDIF.

3.4.6 PROXSTAT Update

PROXSTAT update consists in taking PROXDIF information (C_{User}), comparing it with a user programmable threshold PROXTHRESH and finally updating PROXSTAT accordingly. When PROXSTAT=1, PROXAVG is frozen to prevent the user proximity signal averaging and hence absorbed into C_{Env} .

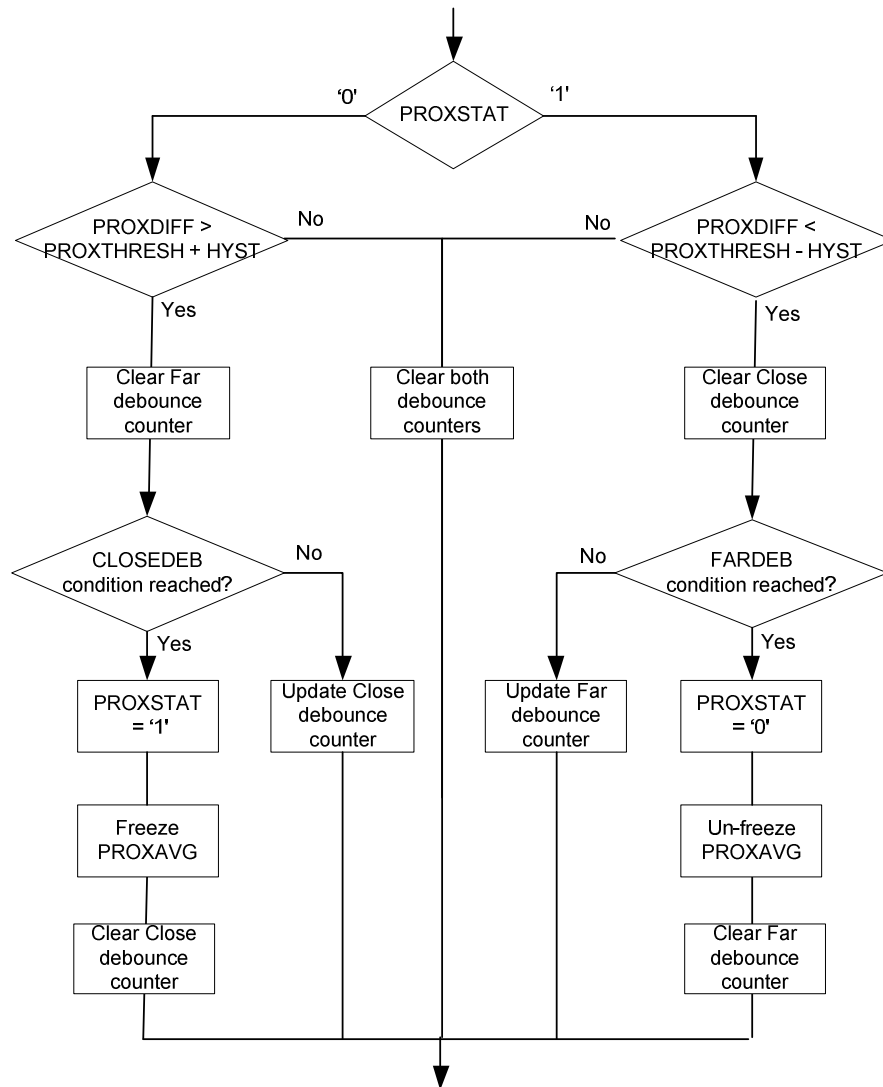
Figure 19: PROXSTAT Update

WIRELESS & SENSING
3.5 Host Operation

An interrupt can be triggered when the user is detected to be close (in range), detected to be far (out of range), or both (CLOSEIRQEN, FARIRQEN).

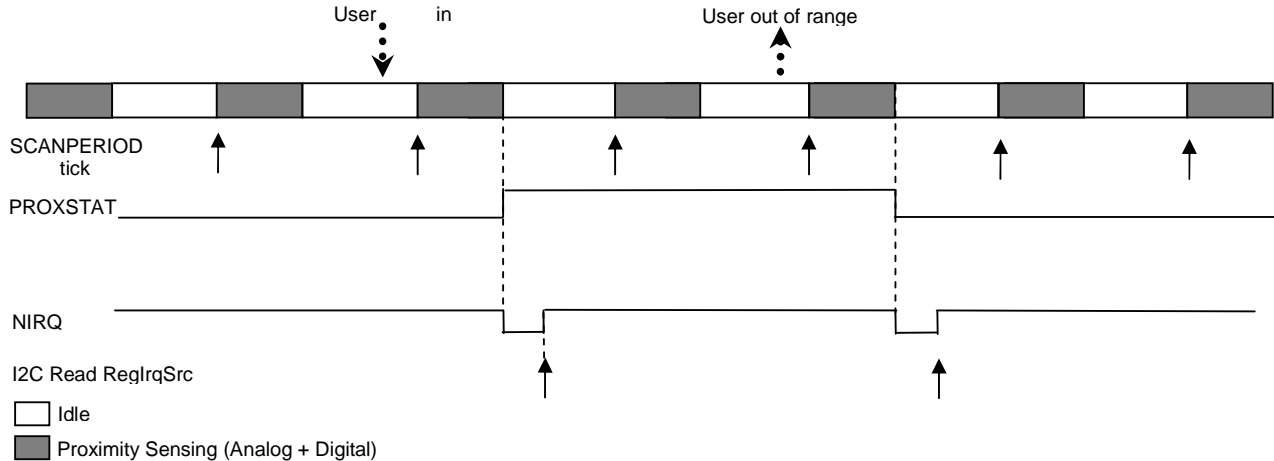

Figure 20: Proximity Sensing Host Operation (RegIrkMsk[6:3] = 1100)

An interrupt can also be triggered at the end of each proximity sensing operation, indicating to the host when the proximity sensing block is running (CONVDONEIRQEN). This may be used by the host to synchronize noisy system operations or to read sensor data (PROXUSEFUL, PROXAVG, PROXDIF) synchronously for monitoring purposes.

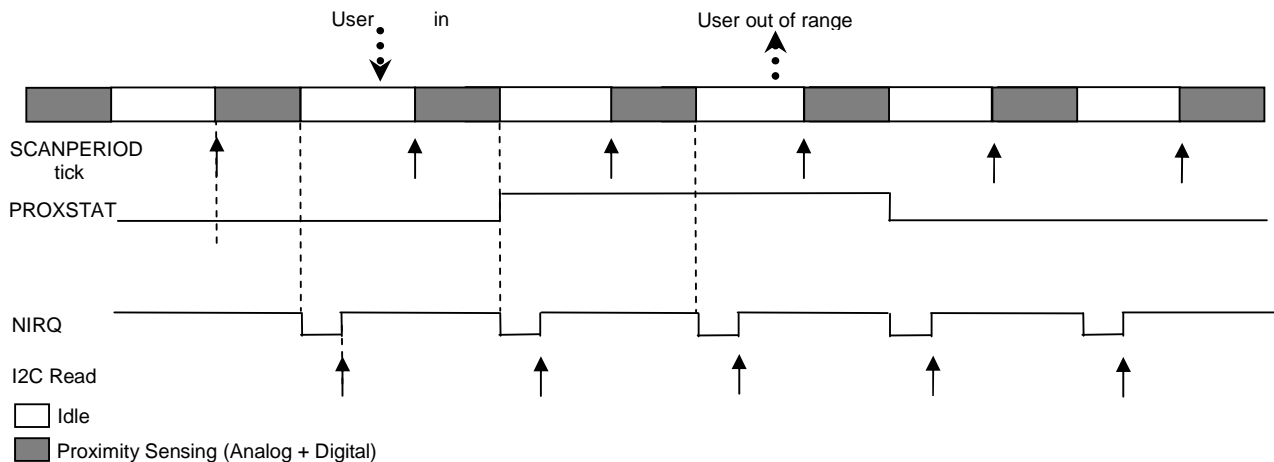

Figure 21: Proximity Sensing Host Operation (RegIrkMsk[6:3] = 0001)

In both cases above, an interrupt can also be triggered at the end of compensation (COMPDONEIRQEN).

3.6 Operational Modes

3.6.1 Active

Active mode has the shortest scan periods, typically 30ms. In this mode, all enabled sensors are scanned and information data is processed within this interval. The Active scan period is user configurable (SCANPERIOD) and can be extended up to 400ms.

3.6.2 Doze

In some applications, the reaction/sensing time needs to be fast when the user is present (proximity detected), but can be slow when not detection has been done for some time.

The Doze mode, when enabled (DOZEEN), allows the chip to automatically switch between a fast scan period (SCANPERIOD) during proximity detection and a slow scan period (DOZEPERIOD) when no proximity is being detected (up to 6.4s). This allows reaching low average power consumption values at the expense obviously of longer reaction times.

As soon as proximity is detected on any sensor, the chip will automatically switch to Active mode while when it has not detected an object for DOZEPERIOD, it will automatically switch to Doze mode.

3.6.3 Sleep

Sleep mode can be entered by disabling all sensors (SENSOREN=0000). It places the SX9300 in its lowest power mode, with sensor scanning completely disabled and idle period set to continuous. In this mode, only the I2C serial bus is active. Enabling any sensor will make the chip leave Sleep mode (for Doze if enabled, else Active mode)

3.6.4 TXEN Pin

The TXEN input enables proximity sensing when HIGH, likewise when the TXEN input is LOW, the SX9300 is in Sleep mode. Specifically, on the rising edge of TXEN the SX9300 will begin measuring the sensors normally at the programmed rate (SCANPERIOD, DOZEPERIOD) as long as TXEN remains HIGH. When TXEN goes LOW the current measurement sequence will complete and then measurement will cease until the next rising edge of TXEN.

This feature can be used to synchronize proximity sensing with noisy and/or RF activity for example.

4 SMART SAR ENGINE

4.1 Introduction

In addition to the proximity sensing interface, the SX9300 also embeds the world's first smart SAR engine which is able to discriminate between proximity generated by low permittivity (table) and high permittivity objects (body). This is typically useful for Specific Absorption Rate (SAR) applications in portable devices (tablets, cellphones, etc) where international regulations (FCC, ETSI, etc) impose to reduce RF power in the presence of human body for safety reasons.

Typical capacitive sensing solutions are not able to discriminate between proximity detection generated when a tablet for example is sitting on a table (no need to reduce RF power) vs when it is sitting the user's lap (need to reduce RF power) resulting in RF power and hence user's experience reduced significantly even when it is not needed.

The SX9300's unique smart SAR engine allows reducing RF power only in the presence of body (high permittivity material) and hence offering significantly better user experience while still conforming to safety regulations.

4.2 Sensor Design

In order to use SX9300's smart SAR engine, the sensors design must follow a few rules which are described in this section.

Each smart SAR sensor is physically made of two sensors (outer and inner) connected respectively to pins CSxA and CSxB. In the drawing below, the dark areas represent copper (conductor) and the light areas represents a non-conductor (spacing between the two copper areas).

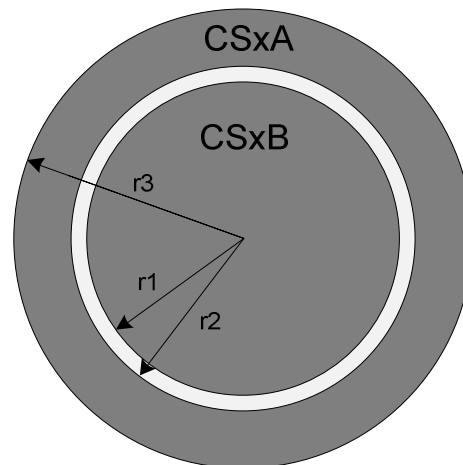

Figure 22: Typical Smart SAR Capacitive Sensor

IMPORTANT: The "A" and "B" sensors cannot be swapped. The outer copper area is always the "A" sensor, and the inner copper area is always the "B" sensor else the smart SAR engine will not operate properly.

For each pair, the copper areas of CSxB and CSxA pads must be designed to be equal (as equal as the FPC/PCB technology tolerance allows).

Figure above illustrates an example of circular shape but smart SAR sensors can of course be designed in a variety of shapes (square, rectangular) depending on the physical/mechanical constraints of the system.

One SX9300 can support up to two pairs of sensors i.e. two smart SAR sensors.

WIRELESS & SENSING**4.3 Processing**

The smart SAR engine is active for a pair of sensors when its CSxPROXSTAT is set i.e. both CSxA and CSxB's internal PROXSTAT values are set (i.e. both sensors of a the same pair have detected proximity).

When active, the smart SAR engine computes two real time values called delta and ratio (SARDELTA, SARRATIO), compares them to their respective user-defined debounced thresholds (SARDELTAHRESH, SARRATIOHRESH, SARDEB) and updates CSxBODYSTAT accordingly (set to 1 when both delta and ratio exceed their respective thresholds).

Note that an hysteresis derivated from HYST is automatically applied to delta and ratio thresholds as defined below:

HYST	Delta Threshold Hysteresis	Ratio Threshold Hysteresis
00	2	2
01	4	4
10	8	6
11	16	8

Table 8: Delta/Ratio Thresholds Hysteresis

WIRELESS & SENSING
5 I2C INTERFACE
5.1 Introduction

The I2C implemented on the SX9300 and used by the host to interact with it is compliant with:

- Standard (100kb/s) and fast mode (400kb/s)
- Slave mode
- 7-bit address (default is 0x28 assuming A1=A0=0)

The SX9300 has two I/O pins (A0 and A1) that provides four possible, user selectable I2C addresses:

A1	A0	Address
0	0	0x28
0	1	0x29
1	0	0x2A
1	1	0x2B

Table 9: I2C Sub-Address Selection

The host can use the I2C to read and write data at any time, and these changes are effective immediately. Therefore the user should ideally disable the sensor before changing settings, or discard the results while changing.

5.2 I2C Write

The format of the I2C write is given in Figure 12. After the start condition [S], the slave address (SA) is sent, followed by an eighth bit ('0') indicating a Write. The SX9300 then Acknowledges [A] that it is being addressed, and the Master sends an 8 bit Data Byte consisting of the SX9300 Register Address (RA). The Slave Acknowledges [A] and the master sends the appropriate 8 bit Data Byte (WD0). Again the Slave Acknowledges [A]. In case the master needs to write more data, a succeeding 8 bit Data Byte will follow (WD1), acknowledged by the slave [A]. This sequence will be repeated until the master terminates the transfer with the Stop condition [P].

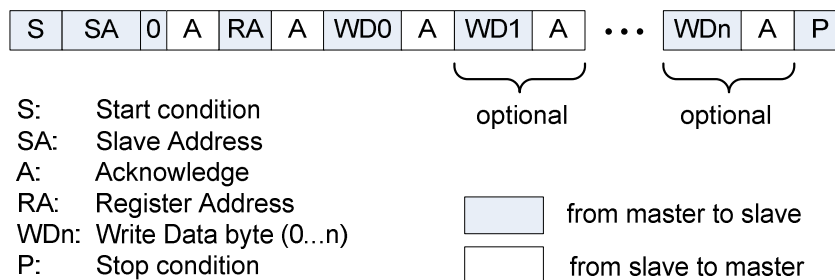

Figure 23: I2C Write

The register address is incremented automatically when successive register data (WD1...WDn) is supplied by the master.

5.3 I2C Read

The format of the I2C read is given in Figure 13. After the start condition [S], the slave address (SA) is sent, followed by an eighth bit ('0') indicating a Write. The SX9300 then Acknowledges [A] that it is being addressed, and the Master responds with an 8-bit Data consisting of the Register Address (RA). The Slave Acknowledges [A] and the master sends the Repeated Start Condition [Sr]. Once again, the slave address (SA) is sent, followed by an eighth bit ('1') indicating a Read. The SX9300 responds with an Acknowledge [A] and the read

WIRELESS & SENSING

Data byte (RD0). If the master needs to read more data it will acknowledge [A] and the SX9300 will send the next read byte (RD1). This sequence can be repeated until the master terminates with a NACK [N] followed by a stop [P].

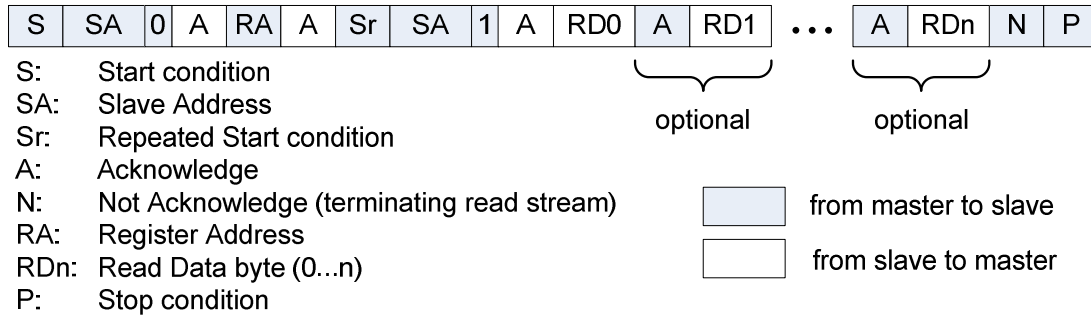

Figure 24: I2C Read

The register address is incremented automatically when successive register data (RD1...RDn) is retrieved by the master.

6 RESET

6.1 Power-up

During a power-up condition, the NIRQ output is HIGH until V_{DD} has met the minimum input voltage requirements and a T_{POR} time has expired upon which, NIRQ asserts to a LOW condition indicating the SX9300 is initialized. The host must perform an I2C read of RegIrqSrc to clear this NIRQ status. The SX9300 is then ready for normal I2C communication and is operational.

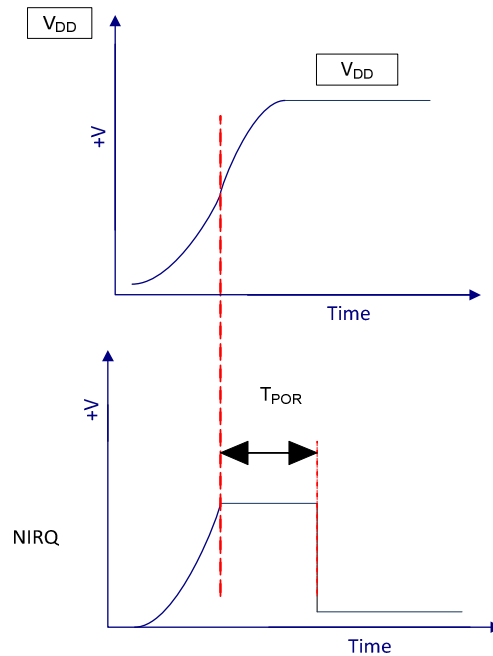

Figure 25: Power-up vs. NIRQ

6.2 NRST Pin

When the host asserts NRST LOW (for min. $T_{RESETPW}$) and then HIGH, the SX9300 will reset its internal registers and will become active after T_{POR} . When not used, this pin must be pulled high to SV_{DD} .

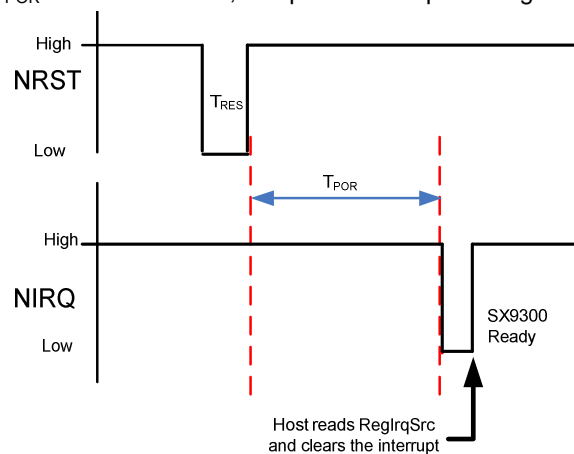

Figure 26: Hardware Reset

WIRELESS & SENSING**6.3 Software Reset**

The host can also perform a reset anytime by writing 0xDE into RegReset. The NIRQ output will be asserted LOW and the Host is required to perform an I2C read to clear this NIRQ status.

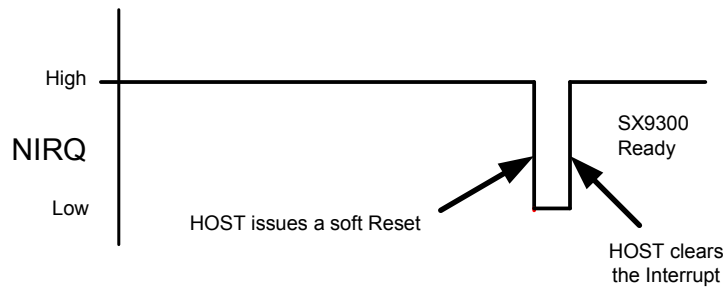

Figure 27: Software Reset

7 INTERRUPT

Except RESETIRQ, all interrupt sources are disabled by default upon power-up and resets, and thus must be enabled by the host. Any or all of the following interrupts can be enabled by writing a “1” into the appropriate locations within the RegIrqMsk register:

- Close (proximity detected)
- Far (proximity un-detected)
- Compensation completed
- Conversion completed

The interrupt status can be read from RegIrqSrc for each of these interrupt sources.

7.1 Power-up

During initial power-up, the NIRQ output is HIGH. Once the SX9300 internal power-up sequence has completed, NIRQ is asserted LOW, signaling that the SX9300 is ready. The host must perform a read to RegIrqSrc to acknowledge and the SX9300 will clear the interrupt and release the NIRQ line.

7.2 Assertion and Clearing

The NIRQ can be asserted in either the Active or Doze mode during a scan period. The NIRQ will be automatically cleared after the host performs a read of RegIrqSrc (which content will be cleared as well).

WIRELESS & SENSING
8 PINS DESCRIPTION
8.1 V_{DD} and SV_{DD}

These are the device supply voltages. V_{DD} is the supply voltage for the internal core. SV_{DD} is the supply voltage for the host interface. NOTE: SV_{DD} MUST be equal or lower than V_{DD} at all times.

8.2 TXEN

This signal can be used in many applications if a conversion trigger/enable is needed. This input pin synchronizes the Capacitance Sensing inputs in systems that need to (for example) transmit RF signals. When this signal is active, SX9300 performs capacitive measurements. If this input becomes inactive during the middle of a measurement, the SX9300 will complete all remaining measurements and will enter sleep mode until TXEN goes active again.

8.3 Capacitive Sensing Interface (CS0A, CS0B, CS1A, CS1B, CSG)

The Capacitance Sensing input pins CS0A, CS0B, CS1A and CS1B are connected directly to the Capacitance Sensing Interface circuitry which converts the sensed capacitance into digital values. The Capacitive Sensor Guard (CSG) output provides a guard reference to minimize the parasitic sensor pin capacitances to ground. Capacitance sensor pins which are not used must not be connected. Additionally, CSx pins must be connected directly to the capacitive sensors using a minimum length circuit trace to minimize external "noise" pick-up.

The capacitance sensor and capacitive sensor guard pins are protected from ESD events to V_{DD} and GROUND.

8.4 Host Interface

The Host Interface consists of: NIRQ, NRST, SCL, SDA, and TXEN. These signals are discussed below.

8.4.1 NIRQ

The NIRQ pin is an open drain output that requires an external pull-up resistor (1...10 kOhm). The NIRQ pin is protected from ESD events to V_{DD} and GROUND.

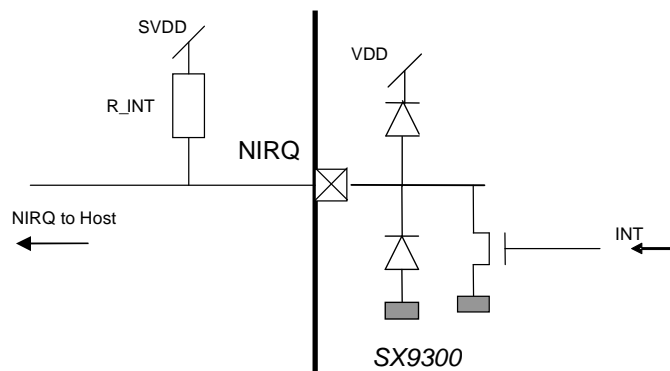

Figure 28: NIRQ Output Simplified Diagram

WIRELESS & SENSING
8.4.2 SCL, NRST and TXEN

The SCL, NRST and TXEN pins are high impedance input pins that require an external pull-up resistor (1..10 kOhm). NRST and TXEN can be connected without the requirement for a pull-up resistor if driven from a push-pull host output. These pins are protected from ESD events to VDD and GROUND.

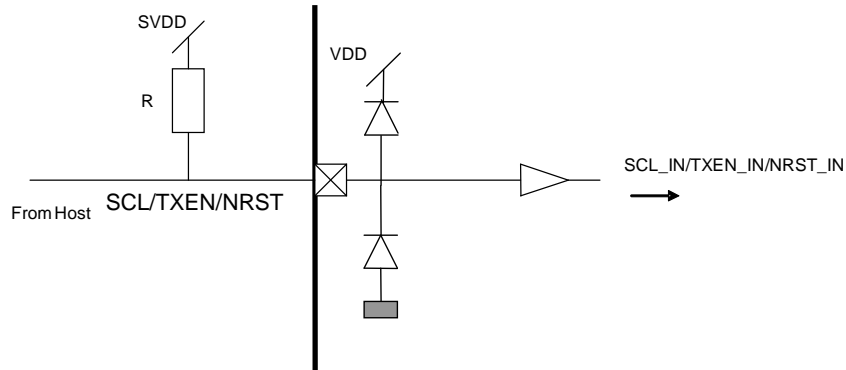

Figure 29: SCL/TXEN/NRST

8.4.3 SDA

SDA is an I/O pin that requires an external pull-up resistor (1...10 kOhm). The SDA I/O pin is protected to VDD and GROUND.

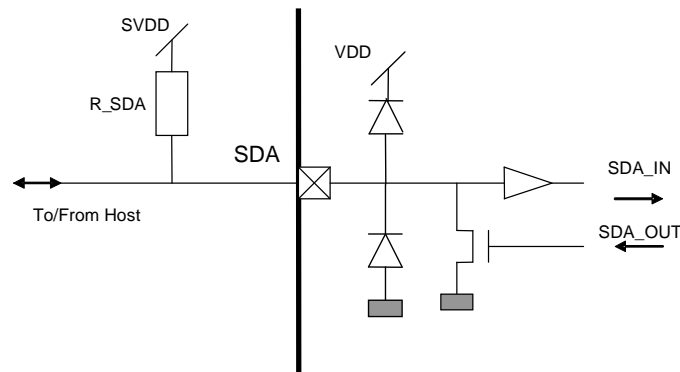

Figure 30: SDA Simplified Diagram

WIRELESS & SENSING
9 REGISTERS
9.1 Overview

The SX9300 allows the user full parameter customization for sensor sensitivity, hysteresis, detection thresholds, etc. Custom parameters are controlled thru the volatile registers below and must be uploaded by the host thru I2C after power-up or after a reset.

Address	Name	Default	Description
0x00	RegIrqSrc	0x80	Interrupt & Status
0x01	RegStat	0x0F	
0x03	RegIrqMsk	0x00	
0x06	RegProxCtrl0	0x0F	Proximity Sensing Control
0x07	RegProxCtrl1	0x40	
0x08	RegProxCtrl2	0x08	
0x09	RegProxCtrl3	0x40	
0x0A	RegProxCtrl4	0x00	
0x0B	RegProxCtrl5	0x00	
0x0C	RegProxCtrl6	0x00	
0x0D	RegProxCtrl7	0x00	
0x0E	RegProxCtrl8	0x00	
0x0F	RegSarCtrl0	0x00	Smart SAR Engine Control
0x10	RegSarCtrl1	0x00	
0x20	RegSensorSel	0x00	Sensor Data Readback
0x21	RegUseMsb	0x00	
0x22	RegUseLsb	0x00	
0x23	RegAvgMsb	0x00	
0x24	RegAvgLsb	0x00	
0x25	RegDiffMsb	0x00	
0x26	RegDiffLsb	0x00	
0x27	RegOffsetMsb	0x00	
0x28	RegOffsetLsb	0x00	
0x29	RegSarDelta	0x00	
0x2A	RegSarRatio	0x00	
0x7F	RegReset	0x00	Software Reset

Table 10: Registers Overview

NOTES:

- 1) Addresses not listed above are reserved and should not be written.
- 2) Reserved bits should be left to their default value unless otherwise specified.

WIRELESS & SENSING
9.2 Detailed Description

Addr.	Name	R/W	Bits	Variable	Default	Function
Interrupt & Status						
0x00	RegIrqSrc	R	7	RESETIRQ	1	Reset interrupt source status. (i.e. reset occurred)
			6	CLOSEIRQ	0	Close interrupt source status. (i.e. CSxPROXSTAT rising edge)
			5	FARIRQ	0	Far interrupt source status. (i.e. CSxPROXSTAT falling edge)
		R/W	4	COMPDONEIRQ	0	Compensation interrupt source status. (i.e. compensation occurred) When set to 1, triggers compensation
		R	3	CONVDONEIRQ	0	Conversion interrupt source status. (i.e. new set of sensor data available)
			2:1	Reserved	00	
		0	TXENSTAT	0	Indicates current TXEN pin status.	
0x01	RegStat	R	7	CS1PROXSTAT	0	Indicates if proximity is being detected for the pair CS1A/CS1B (i.e. both A and B sensor's PROXDIF values are above detection threshold)
			6	CS1BODYSTAT	0	When CS1PROXSTAT=1, indicates if the object detected is a human body. (i.e. delta and ratio values of this pair are above their respective threshold)
			5	CS0PROXSTAT	0	Indicates if proximity is being detected for the pair CS0A/CS0B. (i.e. both A and B sensor's PROXDIF values are above detection threshold)
			4	CS0BODYSTAT	0	When CS0PROXSTAT=1, indicates if the object detected is a human body. (i.e. delta and ratio values of this pair are above their respective threshold)
			3:0	COMPSTAT	1111	Indicates which capacitive sensor(s) has a compensation pending. [3:0] = [CS1B, CS1A, CS0B, CS0A]
0x03	RegIrqMsk	R	7	Reserved	0	
		R/W	6	CLOSEIRQEN	0	Enables the close interrupt.
			5	FARIRQEN	0	Enables the far interrupt.
			4	COMPDONEIRQEN	0	Enables the compensation interrupt.
			3	CONVDONEIRQEN	0	Enables the conversion interrupt.
		R	2:0	Reserved	000	
Proximity Sensing Control						
0x06	RegProxCtrl0	R/W	7	Reserved	0	
			6:4	SCANPERIOD	000	Defines the Active scan period : 000: 30 ms (Typ.) 001: 60 ms 010: 90 ms 011: 120 ms 100: 150 ms 101: 200 ms 110: 300 ms 111: 400 ms Low values will allow fast reaction time while high values will provide low power consumption.
			3:0	SENSOREN	1111	Enables sensor pins.

WIRELESS & SENSING

						[3:0] = [CS1B, CS1A, CS0B, CS0A] Sensors must always be enabled and disabled by pair (CS0A/B; CS1A/B).	
0x07	RegProxCtrl1	R/W	7:6	SHIELDEN	01	Enables shield function on CSG pin: 00: Off, high impedance. 01: On (Typ.) 1x: Reserved	
			R/W	5:2	Reserved	0000	
			R/W	1:0	RANGE	00	Defines the input capacitance range: 00: Large (typ. +/-7.3pF FS) 01: Medium Large (typ. +/-3.7pF FS) 10: Medium Small (typ. +/-3pF FS) 11: Small (typ. +/-2.5pF FS) This parameter can be seen as an analog gain (small range = high gain) Full scale (FS) values assume no digital gain.
0x08	RegProxCtrl2	R/W	7	Reserved	0		
			6:5	GAIN	00	Defines the digital gain factor: 00: Off (x1) 01: x2 10: x4 11: x8 (Typ.) This is a pure digital gain (value shift) applied at the ADC output.	
			4:3	FREQ	01	Defines the sampling frequency: 00: 83 kHz 01: 125 kHz 10: 167 kHz (Typ.) 11: Reserved	
			2:0	RESOLUTION	000	Defines the capacitance measurement resolution/precision: 000: Coarsest 100: Medium 111: Finest (Typ.)	
0x09	RegProxCtrl3	R/W	7	Reserved	0		
			6	DOZEEN	1	Enables Doze mode.	
			5:4	DOZEPERIOD	00	When DOZEN=1, defines the Doze scan period: 00: 2x SCANPERIOD 01: 4x SCANPERIOD 10: 8x SCANPERIOD 11: 16x SCANPERIOD	
			3:2	Reserved	00		
			1:0	RAWFILT	00	Defines PROXRW filter strength : 00: Off - No filtering 01: Low (Typ.) 10: Medium 11: High - Max filtering	
0x0A	RegProxCtrl4	R/W	7:0	AVGTHRESH	0x00	Defines the positive and negative average thresholds which will trigger compensation: Thresholds = +/- 128x AVGTHRESH Typically set between +/-16384 and +/-24576 (i.e. 1/2 to 3/4 of the system)	

WIRELESS & SENSING

						dynamic range). Should not be set below 0x40.
0x0B	RegProxCtrl5	R/W	7:6	AVGDEB	00	Defines the average debouncer applied to AVGTHRESH: 00: Off 01: 2 samples 10: 4 samples 11: 8 samples
			5:3	AVGNEGFILT	000	Defines the average negative filter strength: 000: Off - No filtering 001: Lowest (Typ.) 111: Highest - Max filtering
			2:0	AVGPOSFILT	000	Defines the average positive filter strength: 000: Off - No filtering 001: Lowest 111: Highest - Max filtering (Typ.)
0x0C	RegProxCtrl6	R/W	7:5	Reserved	000	
			4:0	PROXTHRESH	00000	Defines the proximity detection threshold (for all sensors). 00000: 0 00001: 20 00010: 40 00011: 60 00100: 80 00101: 100 00110: 120 00111: 140 01000: 160 01001: 180 01010: 200 01011: 220 01100: 240 01101: 260 01110: 280 01111: 300 10000: 350 10001: 400 10010: 450 10011: 500 10100: 600 10101: 700 10110: 800 10111: 900 11000: 1000 11001: 1100 11010: 1200 11011: 1300 11100: 1400 11101: 1500 11110: 1600 11111: 1700 Low values allow good sensitivity/distance while higher values allow better noise immunity.
0x0D	RegProxCtrl7	R/W	7	AVGCOMPDIS	0	Disables the automatic compensation triggered by AVGTHRESH.

WIRELESS & SENSING

			6	COMPMETHOD	0	Defines the compensation method: 0: Compensate each CSx pin independently (Typ.) 1: Compensate all CSx pins together.
			5:4	HYST	00	Defines the proximity detection hysteresis applied to PROXTHRESH: 00: 32 01: 64 10: 128 11: 256
			3:2	CLOSEDEB	00	Defines the Close debouncer applied to PROXTHRESH: 00: Off 01: 2 samples 10: 4 samples 11: 8 samples
			1:0	FARDEB	00	Defines the Far debouncer applied to PROXTHRESH: 00: Off 01: 2 samples 10: 4 samples 11: 8 samples
0x0E	RegProxCtrl8	R/W	7:4	STUCK	0000	Defines the proximity "stuck" timeout: 0000 : Off (Typ.) 00XX: STUCK x 64 samples 01XX: STUCK x 128 samples 1XXX: STUCK x 256 samples
			3:0	COMPPRD	0000	Defines the periodic compensation interval: 0000: Off (Typ.) Else: COMPPRD x 128 samples
Smart SAR Engine Control						
0x0F	RegSarCtrl0	R/W	7:6	Reserved	00	
			5:4	SARDEB	00	Defines the SAR engine debouncer applied to human body reporting (CSxBODYSTAT): 00: Off 01: 2 samples 10: 4 samples 11: 8 samples
			3:0	SARDELTATHRESH	0000	Defines the SAR delta threshold (for both sensor pairs): 0000: Off 0001: 1 0010: 3 0011: 5 0100: 10 0101: 15 0110: 20 0111: 25 1000: 30 1001: 35 1010: 40 1011: 45 1100: 50 1101: 55 1110: 60 1111: 70 A hysteresis derived from HYST is

WIRELESS & SENSING

						automatically applied, Cf. §4. Off when set to 0000, i.e. delta value not used for body detection. At least one of Delta or Ratio Threshold must be enabled.
0x10	RegSarCtrl1	R/W	7:0	SARRATIOTHRESH	0x00	Defines the SAR ratio threshold (for both sensor pairs) A hysteresis derivated from HYST is automatically applied, Cf. §4. Off when set to 0x00, i.e. ratio value not used for body detection. At least one of Delta or Ratio Threshold must be enabled.
Sensor Data Readback						
0x20	RegSensorSel	R	7:2	Reserved	000000	
		RW	1:0	SENSORSEL	00	Defines which sensor's data will be available in registers RegUseMsb to RegSarRatio (addr. 0x21 to 0x2A): 00: CS0A 01: CS0B 10: CS1A 11: CS1B
0x21	RegUseMsb	R	7:0	PROXUSEFUL	0x00	Useful current value.
0x22	RegUseLsb	R	7:0		0x00	Signed, 2's complement format.
0x23	RegAvgMsb	R	7:0	PROXAVG	0x00	Average current value.
0x24	RegAvgLsb	R	7:0		0x00	Signed, 2's complement format.
0x25	RegDiffMsb	R	7:0	PROXDIFF	0x00	Diff current value.
0x26	RegDiffLsb	R	7:0		0x00	Signed, 2's complement format.
0x27	RegOffsetMsb	R/W	7:0	PROXOFFSET	0x00	Compensation offset current value.
0x28	RegOffsetLsb	R/W	7:0		0x00	Unsigned. To force a value, MSB and LSB registers must be written in sequence and change is effective after LSB.
0x29	RegSarDelta	R	7	Reserved	0	
			6:0	SARDELTA	0000000	SAR Delta current value of the pair. Signed, 2's complement format
0x2A	RegSarRatio	R	7:0	SARRATIO	0x00	SAR Ratio current value of the pair. Unsigned.
Software Reset						
0x7F	RegReset	W	7:0	SOFTRESET	0x00	Writing 0xDE resets the chip.

Table 11: Registers Detailed Description

10 APPLICATION INFORMATION
10.1 Typical Application Circuit

Figure 31: Typical Application Circuit

10.2 External Components Recommended Values

Symbol	Description	Note	Min	Typ.	Max	Unit
CVDD	Core supply decoupling capacitor		-	100	-	nF
CSVDD	Host interface supply decoupling capacitor		-	100	-	nF
RPULL	Host interface pull-ups	+/- 50%	-	10	-	kΩ

Table 12: External Components Recommended Values

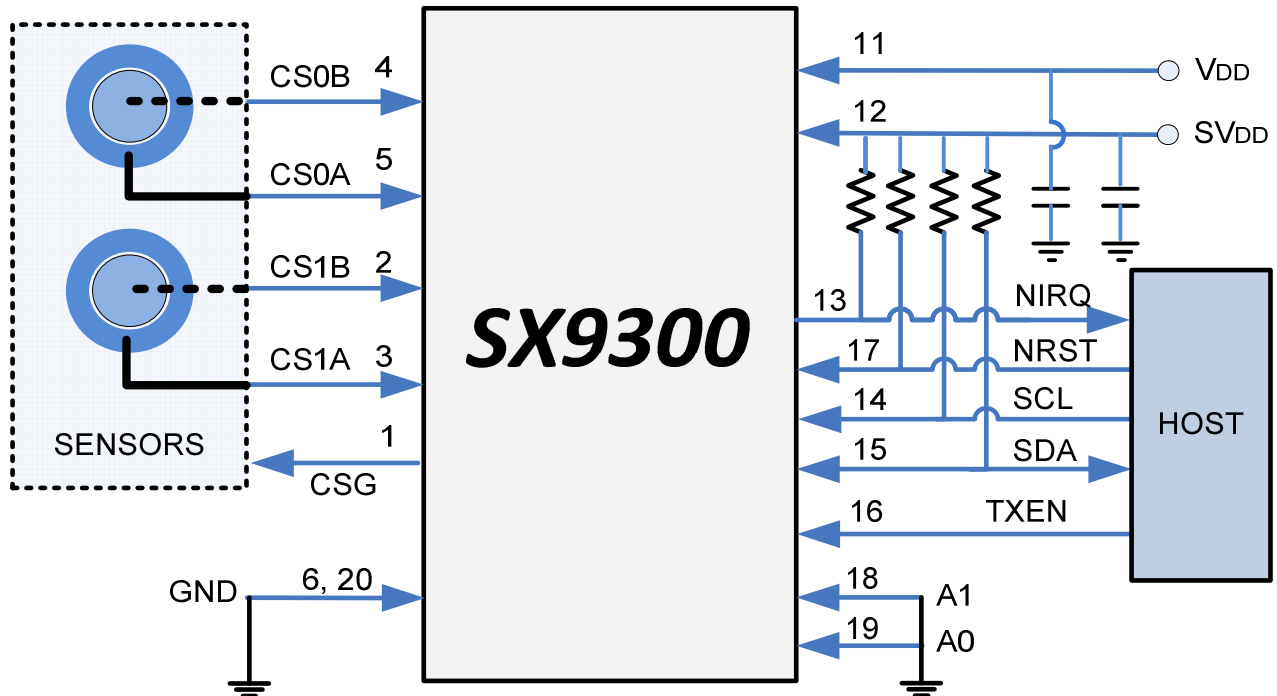
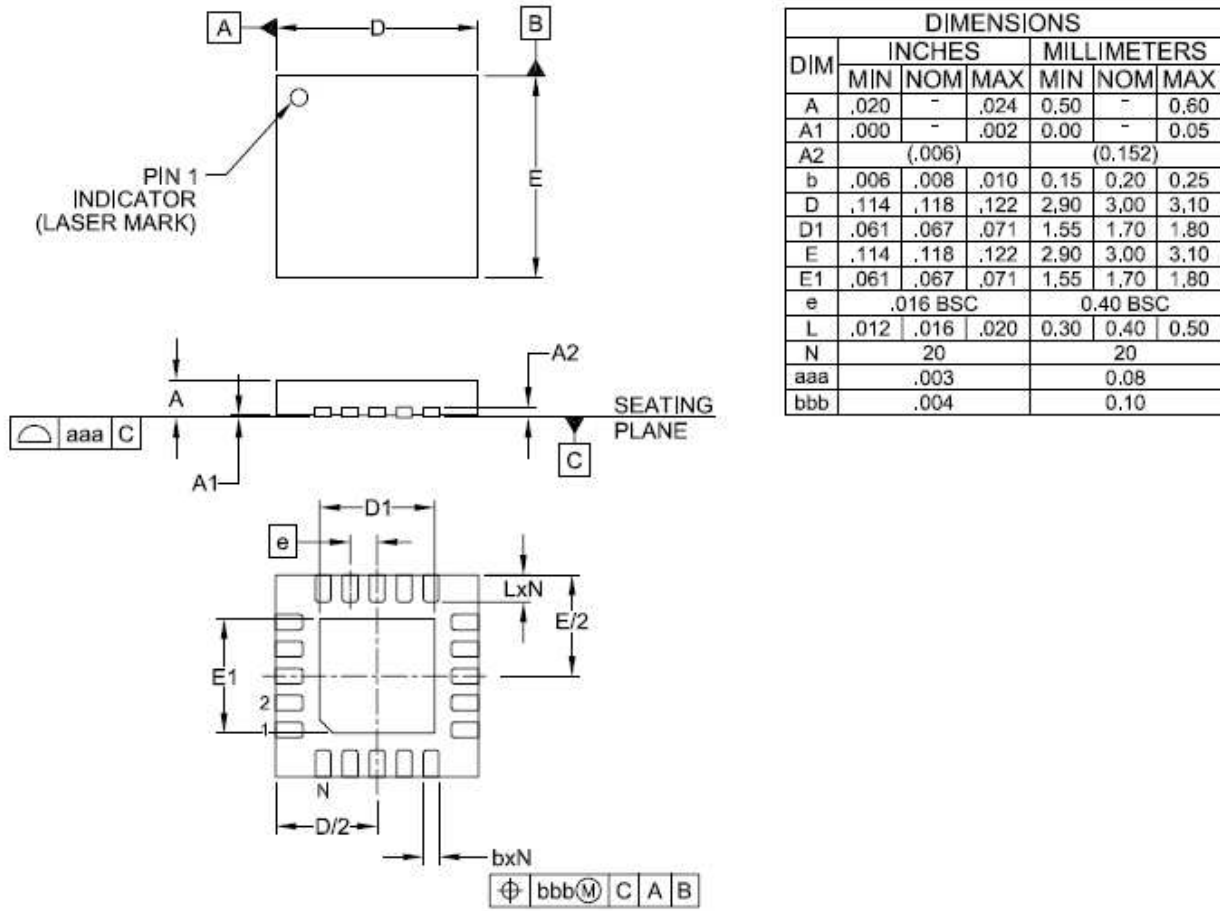
WIRELESS & SENSING
11 PACKAGING INFORMATION
11.1 Outline Drawing

NOTES:

1. CONTROLLING DIMENSIONS ARE IN MILLIMETERS (ANGLES IN DEGREES).
2. COPLANARITY APPLIES TO THE EXPOSED PAD AS WELL AS THE TERMINALS.
3. DAP IS 1.90 x 1.90mm.

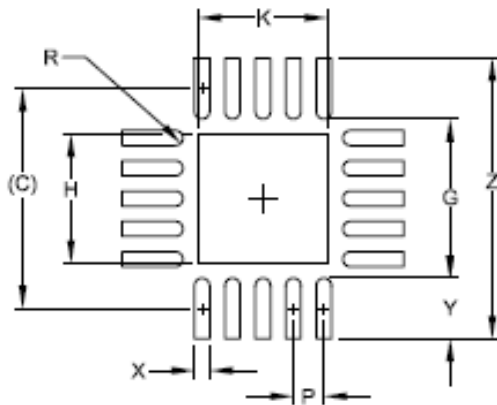
Figure 32: Outline Drawing

WIRELESS & SENSING
11.2 Land Pattern

DIMENSIONS		
DIM	INCHES	MILLIMETERS
C	(.114)	(2.90)
G	.083	2.10
H	.067	1.70
K	.067	1.70
P	.016	0.40
R	.004	0.10
X	.008	0.20
Y	.031	0.80
Z	.146	3.70

NOTES:

1. CONTROLLING DIMENSIONS ARE IN MILLIMETERS (ANGLES IN DEGREES).
2. THIS LAND PATTERN IS FOR REFERENCE PURPOSES ONLY. CONSULT YOUR MANUFACTURING GROUP TO ENSURE YOUR COMPANY'S MANUFACTURING GUIDELINES ARE MET.
3. THERMAL VIAS IN THE LAND PATTERN OF THE EXPOSED PAD SHALL BE CONNECTED TO A SYSTEM GROUND PLANE. FAILURE TO DO SO MAY COMPROMISE THE THERMAL AND/OR FUNCTIONAL PERFORMANCE OF THE DEVICE.

Figure 33: Land Pattern

WIRELESS & SENSING

© Semtech 2014

All rights reserved. Reproduction in whole or in part is prohibited without the prior written consent of the copyright owner. The information presented in this document does not form part of any quotation or contract, is believed to be accurate and reliable and may be changed without notice. No liability will be accepted by the publisher for any consequence of its use. Publication thereof does not convey nor imply any license under patent or other industrial or intellectual property rights. Semtech assumes no responsibility or liability whatsoever for any failure or unexpected operation resulting from misuse, neglect improper installation, repair or improper handling or unusual physical or electrical stress including, but not limited to, exposure to parameters beyond the specified maximum ratings or operation outside the specified range.

SEMTECH PRODUCTS ARE NOT DESIGNED, INTENDED, AUTHORIZED OR WARRANTED TO BE SUITABLE FOR USE IN LIFE-SUPPORT APPLICATIONS, DEVICES OR SYSTEMS OR OTHER CRITICAL APPLICATIONS. INCLUSION OF SEMTECH PRODUCTS IN SUCH APPLICATIONS IS UNDERSTOOD TO BE UNDERTAKEN SOLELY AT THE CUSTOMER'S OWN RISK. Should a customer purchase or use Semtech products for any such unauthorized application, the customer shall indemnify and hold Semtech and its officers, employees, subsidiaries, affiliates, and distributors harmless against all claims, costs damages and attorney fees which could arise.

Notice: All referenced brands, product names, service names and trademarks are the property of their respective owners.

Contact Information

Semtech Corporation
Wireless and Sensing Products Division
200 Flynn Road, Camarillo, CA 93012
Phone: (805) 498-2111 Fax: (805) 498-3804

X-ON Electronics

Largest Supplier of Electrical and Electronic Components

Click to view similar products for [Touch Sensor Development Tools](#) category:

Click to view products by [Semtech](#) manufacturer:

Other Similar products are found below :

[TSC2100EVM](#) [TSC2003EVM-PDK](#) [ATMXT1066T2-DEV-PCB](#) [ATMXT336UDEVPCB](#) [LC717A00ARGEVK](#) [ATMXT641TDAT-I2C-PCB](#)
[MAX20353EVSYS#_1374](#) [MIKROE-1906_1602](#) [SEN0164_1982](#) [STEVAL-PCC009V3](#) [ATSAMD20-QTRDEMO](#) [ATQT2-XPRO](#) [ATQT6-XPRO_2340](#) [DM160221](#) [DM160229](#) [DM160222](#) [ATQT5-XPRO](#) [DFR0129](#) [SEN0170](#) [SLEXP8019A](#) [SLEXP8018A_1375](#) [SEN0186](#)
[SEN0148](#) [DK-000013-03](#) [ROB0103](#) [cs-useful-01](#) [DFR0385](#) [SEN0184](#) [SX8651EVKA_1362](#) [2024_3575](#) [4830](#) [AS8579-TS_EK_DB](#)
[ATQT600](#) [IQS227/228ASEV01](#) [SKU-6515](#) [CY3280-MBR2](#) [CY3280-MBR3](#) [DFR0030](#) [DM160219](#) [AC160219](#) [AC320007](#) [AC47H23A](#)
[ATEVK-MXT1066T2-A](#)