

### TRIUNE PRODUCTS

### Features

- Fixed output voltage choices: 1.5V, 1.8V, 2.5V, 3.3V, and 5V with  $\pm 2\%$  output tolerance
- Adjustable version output voltage range: 0.9V to (VCC - 1V) with  $\pm 1.5\%$  reference
- Wide input voltage range: 4.5V to 40V (42V Abs Max)
- 2.2MHz  $\pm 10\%$  fixed switching frequency
- Continuous output current: 1A for TS30041Q and 2A for TS30042Q
- High efficiency up to 90%
- Current mode PWM control with PFM mode for improved light load efficiency
- Voltage supervisor for V<sub>OUT</sub> reporting (Power Good)
- Input supply under voltage lockout and soft start
- Full protection for over-current, over-temperature, and V<sub>OUT</sub> over-voltage
- SYNC function on EN/SYNC pin to control switching frequency
- Less than 10uA in standby mode with low external component count
- AEC-Q100 Grade-2 qualified

### Applications

- Power rails in automotive applications
- Industrial power supplies

### Description

The TS30041Q (1A) and TS30042Q (2A) are DC/DC synchronous switching regulators with fully integrated power switches, internal compensation and full fault protection. The switching frequency of 2.2 MHz enables the use of small filter components resulting in minimal board space and reduced BOM costs.

The TS30041Q/42Q utilizes current mode feedback in normal regulation PWM mode. When the regulator is placed in standby (EN is low), the device draws less than 10uA quiescent current.

The TS30041Q/42Q integrates a wide range of protection circuitry including input supply under-voltage lockout, output voltage soft start, current limit and thermal shutdown.

The TS30041Q/42Q includes supervisory reporting through the PG (Power Good) open drain output to interface other components in the system.

### Summary Specification

- Junction operating temperature -40°C to +125°C
- Packaged in a 16pin QFN (3x3)
- ROHS: "Product is lead-free, Halogen Free, RoHS/WEEE compliant"

### Typical Application Circuit

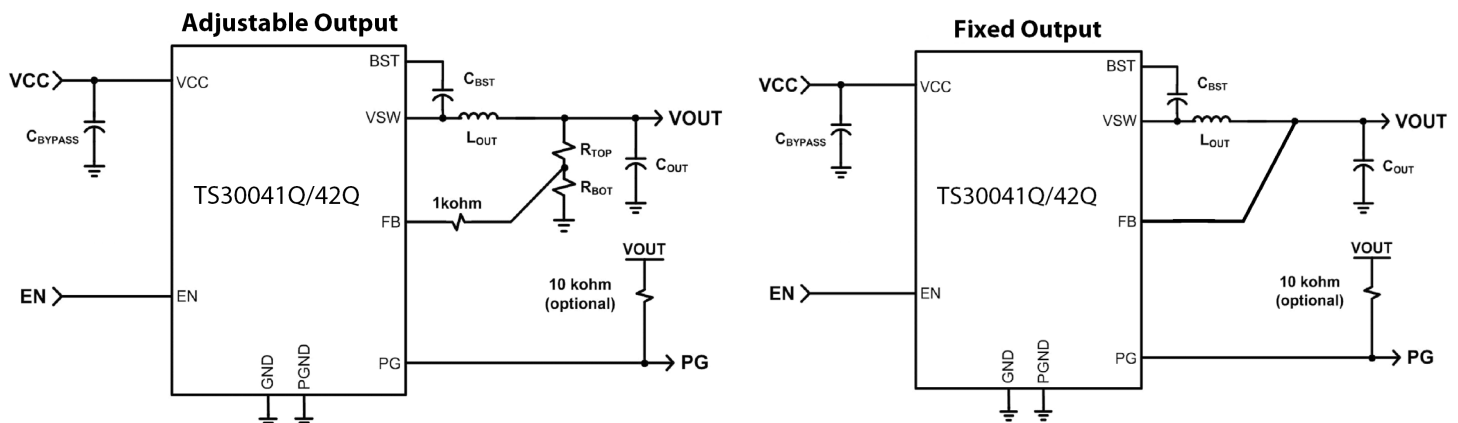

## Pin Configuration

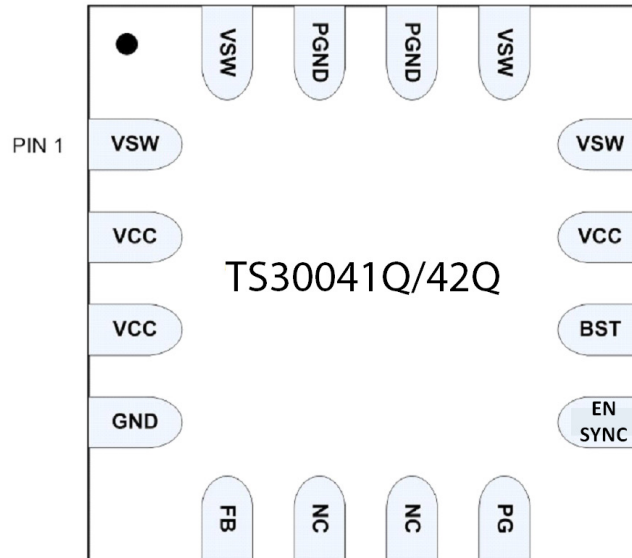

Figure 1: 16 Lead 3x3 QFN, Top View

## Pin Description

Pin #	Pin Symbol	Function	Description
1	VSW	Switching Voltage Node	Connected to 4.7 $\mu$ H (typical) inductor
2	VCC	Input Voltage	Input voltage
3	VCC	Input Voltage	Input voltage
4	GND	GND	Primary ground for the majority of the device except the low-side power FET
5	FB	Feedback Input	Regulator FB Voltage. Connects to VOUT for fixed mode and the output resistor divider for adjustable mode
6	NC	No Connect	Not Connected
7	NC	No Connect	Not Connected
8	PG	Power Good Output	Open-drain output
9	EN/SYNC	Enable & Sync Input	Above 2.2V the device is enabled. GND the pin to put device in standby mode. Includes internal pull-up. Also used for SYNC function
10	BST	Bootstrap Capacitor	Bootstrap capacitor for the high-side FET gate driver. A ceramic capacitor in the range 15 nF - 200 nF from BST pin to VSW pin
11	VCC	Input Voltage	Input Voltage
12	VSW	Switching Voltage Node	Connected to 4.7 $\mu$ H (typical) inductor
13	VSW	Switching Voltage Node	Connected to 4.7 $\mu$ H (typical) inductor
14	PGND	Power GND	GND supply for internal low-side FET/integrated diode
15	PGND	Power GND	GND supply for internal low-side FET/integrated diode
16	VSW	Switching Voltage Node	Connected to 4.7 $\mu$ H (typical) inductor
	PAD	Power PAD	Power GND

# Functional Block Diagrams

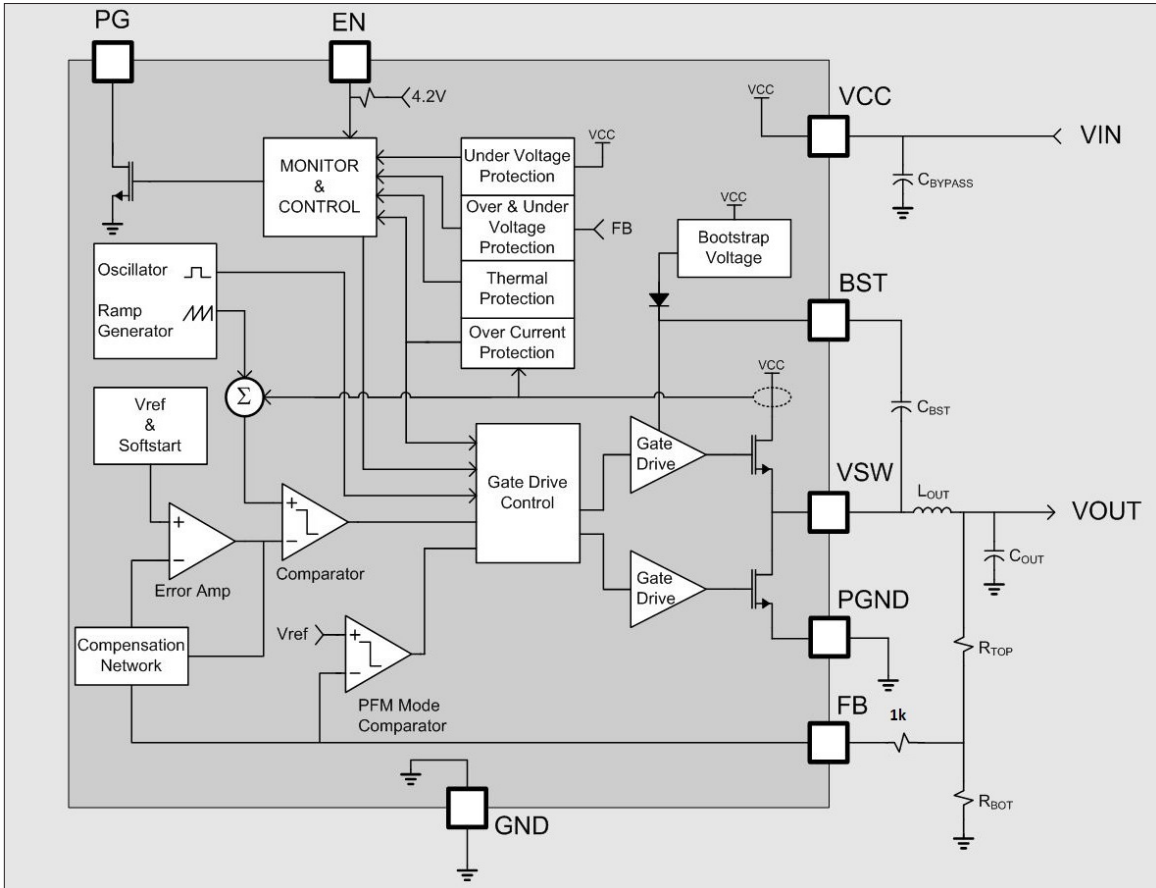

Figure 2: TS30041Q/42Q Block Diagram

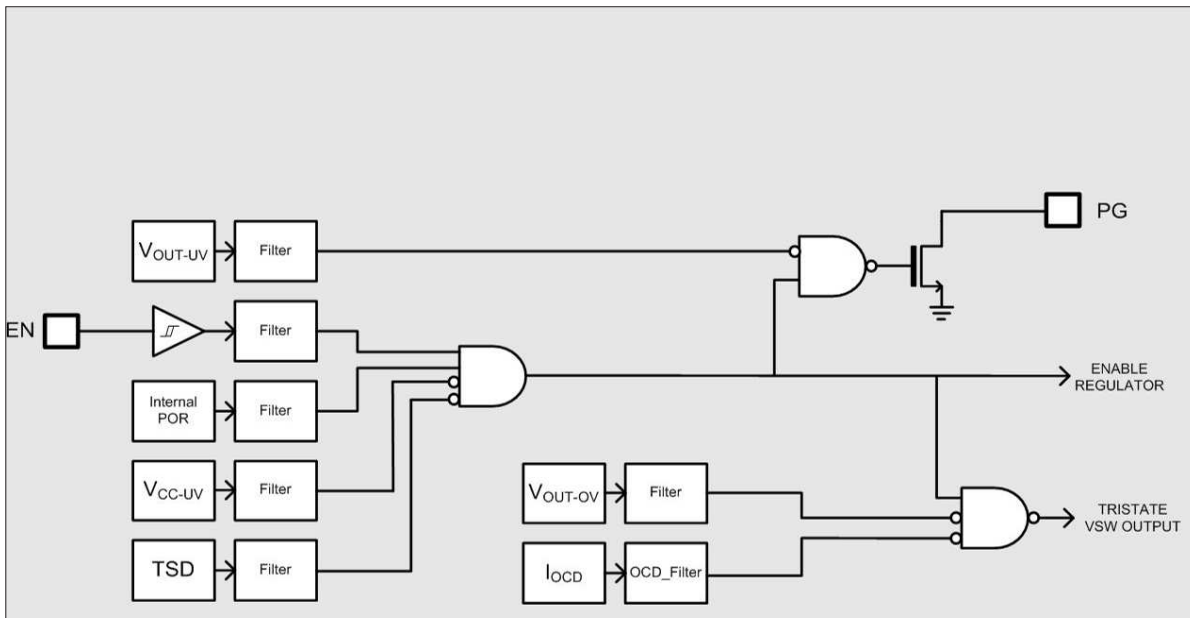

Figure 3: Monitor & Control Logic Functionality

## Absolute Maximum Ratings

Over operating free air temperature range unless otherwise noted<sup>(1,2,3)</sup>

Parameter	Value	Unit
VCC	-0.3 to 42	V
BST	-0.3 to (VCC+6)	V
VSW	-1 to 42	V
EN, PG, FB	-0.3 to 6	V
Electrostatic Discharge – Human Body Model	±2k	V
Electrostatic Discharge – Charge Device Model	±500	V
Lead Temperature (soldering, 10 seconds)	260	°C

Note 1: Stresses beyond those listed under “absolute maximum ratings” may cause permanent damage to the device. These are stress ratings only and functional operation of the device at these or any other conditions beyond those indicated under “recommended operating conditions” is not implied. Exposure to absolute–maximum–rated conditions for extended periods may affect device reliability.

Note 2: All voltage values are with respect to network ground terminal.

Note 3: MOSFETs minimum breakdown voltage is 48V.

## Thermal Characteristics

Over operating free–air temperature range unless otherwise noted<sup>(1,2)</sup>

Symbol	Parameter	Value	Unit
$\theta_{JA}$	Thermal Resistance Junction to Air <sup>(Note 1)</sup>	34.5	°C/W
$\theta_{JC}$	Thermal Resistance Junction to Case <sup>(Note 1)</sup>	2.5	°C/W
$T_{STG}$	Storage Temperature Range	-65 to +150	°C
$T_{J\ MAX}$	Maximum Junction Temperature	150	°C
$T_J$	Operating Junction Temperature Range	-40 to +125	°C

Note 1: Assumes 16LD 3x3 QFN with hi-K JEDEC board and 13.5 inch<sup>2</sup> of 1 oz Cu and 4 thermal vias connected to PAD.

## Recommended Operating Conditions

Symbol	Parameter	Min	Typ	Max	Units
$V_{CC}$	Input Operating Voltage	4.5	12	40	V
$C_{BST}$	Bootstrap Capacitor	15	22	200	nF
$L_{OUT}$	Output Filter Inductor Typical Value <sup>(Note 1)</sup>	3.76	4.7	5.64	μH
$C_{OUT}$	Output Filter Capacitor Typical Value <sup>(Note 2)</sup>	33	44 (2 x 22)		μF
$C_{OUT-ESR}$	Output Filter Capacitor ESR	2		100	mΩ
$C_{BYPASS}$	Input Supply Bypass Capacitor Typical Value <sup>(Note 3)</sup>	8	10		μF
$T_{AMBIENT}$	Operating Ambient Temperature Range	-40		+105	°C

Note 1: For best performance, an inductor with a saturation current rating higher than the maximum  $I_{OUT}$  load requirement plus the inductor current ripple.

Note 2: For best performance, a low ESR ceramic capacitor should be used.

Note 3: For best performance, a low ESR ceramic capacitor should be used. If  $C_{BYPASS}$  is not a low ESR ceramic capacitor, a 0.1μF ceramic capacitor should be added in parallel to  $C_{BYPASS}$ .

# Electrical Characteristics

Electrical Characteristics,  $T_j = -40^{\circ}\text{C}$  to  $+125^{\circ}\text{C}$ ,  $V_{CC} = 12\text{V}$  (unless otherwise noted)

Parameter	Symbol	Condition	Min	Typ	Max	Units
<b>VCC Supply Voltage</b>						
Input Supply Voltage	$V_{CC}$		4.5		40	V
Quiescent current Normal Mode	$I_{CC-NORM}$	$V_{CC} = 12\text{V}, I_{LOAD} = 0\text{A}$		5	10	mA
Quiescent current Normal Mode – Non-switching	$I_{CC-NOSWITCH}$	$V_{CC} = 12\text{V}, I_{LOAD} = 0\text{A},$ Non-switching		2.5		mA
Quiescent current Standby Mode	$I_{CC-STBY}$	$V_{CC} = 12\text{V}, EN = 0\text{V}$		6	12	$\mu\text{A}$
<b>VCC Under Voltage Lockout</b>						
Input Supply Under Voltage Threshold	$V_{CC-UV}$	$V_{CC}$ Increasing		4.3	4.5	V
Input Supply Under Voltage Threshold Hysteresis	$V_{CC-UV-HYST}$			350		mV
<b>OSC</b>						
Oscillator Frequency (Internal)	$f_{OSC}$			2.2		MHz
SYNC Frequency <sup>(1)</sup>	$f_{SYNC}$		0.3		2.2	MHz
<b>PG Open Drain Output</b>						
PG Release Timer	$t_{PG}$			10		ms
High-Level Output Leakage	$I_{OH-PG}$	$V_{PG} = 5\text{V}$		0.5		$\mu\text{A}$
Low-Level Output Voltage	$V_{OL-PG}$	$I_{PG} = -0.3\text{mA}$			0.01	V
<b>EN/Sync Input Voltage Thresholds</b>						
High Level Input Voltage	$V_{IH-EN}$		2.2			V
Low Level Input Voltage	$V_{IL-EN}$				0.8	V
Input Hysteresis	$V_{HYST-EN}$			480		mV
Input Leakage	$I_{IN-EN}$	$V_{EN} = 5\text{V}$		3.5		$\mu\text{A}$
		$V_{EN} = 0\text{V}$		-1.5		$\mu\text{A}$
<b>Thermal Shutdown</b>						
Thermal Shutdown Junction Temperature	TSD	Note: not tested in production	150	170		$^{\circ}\text{C}$
TSD Hysteresis	$TSD_{HYST}$	Note: not tested in production		10		$^{\circ}\text{C}$

Note 1: SYNC frequency range is tested with a square wave. Operation with a 200ns minimum high pulse is required.

# Regulator Characteristics

Electrical Characteristics,  $T_j = -40^{\circ}\text{C}$  to  $+125^{\circ}\text{C}$  (unless otherwise noted)

Parameter	Symbol	Condition	Min	Type	Max	Units
<b>Switch Mode Regulator: L=4.7<math>\mu</math>H and C=2 x 22<math>\mu</math>F</b>						
Output Voltage Tolerance in PWM Mode	$V_{\text{OUT-PWM}}$	$I_{\text{LOAD}} = 1\text{A}$	$V_{\text{OUT}} - 2\%$	$V_{\text{OUT}}$	$V_{\text{OUT}} + 2\%$	V
Output Voltage Tolerance in PFM Mode	$V_{\text{OUT-PFM}}$	$I_{\text{LOAD}} = 0\text{A}$	$V_{\text{OUT}} - 1\%$	$V_{\text{OUT}} + 1\%$	$V_{\text{OUT}} + 3.5\%$	V
High Side Switch On Resistance	$R_{\text{DS(ON)}}$	$I_{\text{VSW}} = -1\text{A}$ (Note 1)		180		m $\Omega$
Low Side Switch On Resistance		$I_{\text{VSW}} = 1\text{A}$ (Note 1)		120		m $\Omega$
Output Current	$I_{\text{OUT}}$	TS30042Q (Note 4)			2	A
		TS30041Q (Note 4)			1	A
Over Current Detect (High Side Switch Current)	$I_{\text{OCD}}$	TS30042Q	3.0	3.5	4.0	A
		TS30041Q	1.4	1.8	2.4	A
Feedback Reference (Adjustable Mode)	$\text{FB}_{\text{TH}}$	(Note 3)	0.886	0.9	0.914	V
Feedback Reference Tolerance	$\text{FB}_{\text{TH-TOL}}$	(Note 3)	-1.5		1.5	%
Soft start Ramp Time	$T_{\text{SS}}$	Guaranteed by Design		4		ms
PFM Mode FB Comparator Threshold	$\text{FB}_{\text{TH-PFM}}$			$V_{\text{OUT}} + 1\%$		V
VOUT Under Voltage Threshold	$V_{\text{OUT-UV}}$		$91\% V_{\text{OUT}}$	$93\% V_{\text{OUT}}$	$95\% V_{\text{OUT}}$	
VOUT Under Voltage Hysteresis	$V_{\text{OUT-UV-HYST}}$			$1.5\% V_{\text{OUT}}$		
VOUT Over Voltage Threshold	$V_{\text{OUT-OV}}$			$103\% V_{\text{OUT}}$		
VOUT Over Voltage Hysteresis	$V_{\text{OUT-OV-HYST}}$			$1\% V_{\text{OUT}}$		
Max Duty Cycle	$\text{DUTY}_{\text{MAX}}$	(Note 2)	95%	97%	99%	
Minimum On Time	$T_{\text{ON-MIN}}$	Not tested in production		100		ns

Note 1:  $R_{\text{DS(ON)}}$  is characterized at 1A and tested at lower current in production.

Note 2: Regulator VSW pin is forced off for 240ns every 16 cycles to ensure the BST cap is replenished.

Note 3: For the adjustable version, the ratio of  $V_{\text{CC}}/V_{\text{OUT}}$  cannot exceed 7.

Note 4: Based on Over Current Detect testing

# Typical Performance Characteristics (Subject to Change)

$T_j = -40^{\circ}\text{C}$  to  $125^{\circ}\text{C}$ ,  $V_{CC} = 12\text{V}$  (unless otherwise noted)

Figure 4. Startup Response

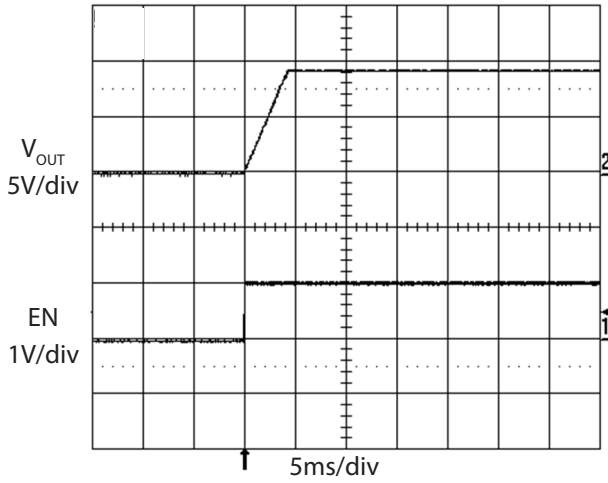

Figure 5. 100mA to 1A Load Step ( $V_{CC}=12\text{V}$ ,  $V_{OUT}=3.3\text{V}$ )

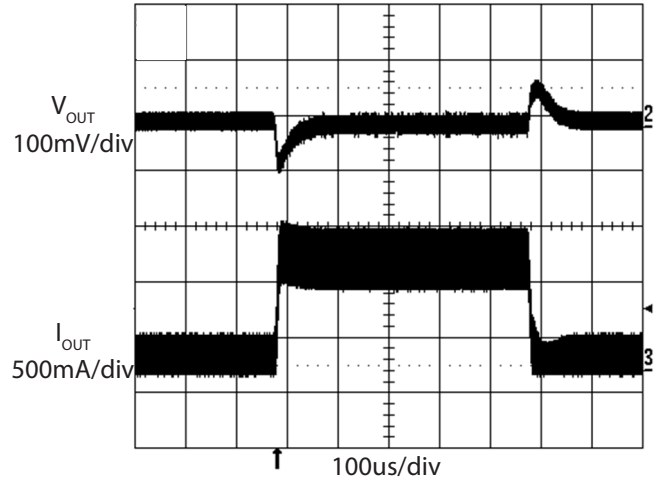

Figure 6. 100mA to 2A Load ( $V_{CC}=12\text{V}$ ,  $V_{OUT}=3.3\text{V}$ )

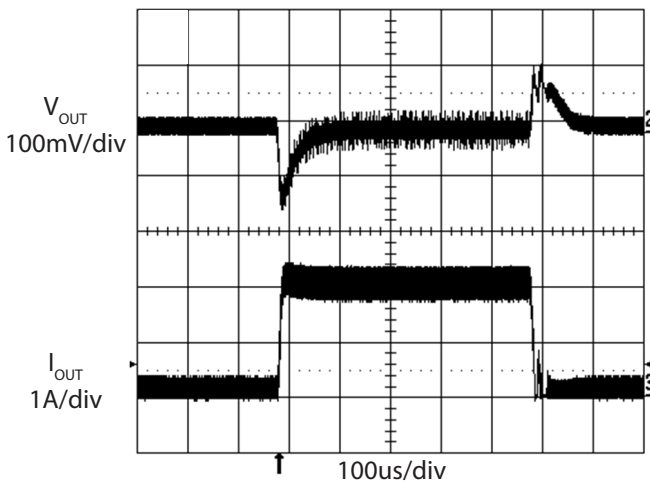

Figure 7. 100mA to 1A Load Step ( $V_{CC}=12\text{V}$ ,  $V_{OUT}=1.8\text{V}$ )

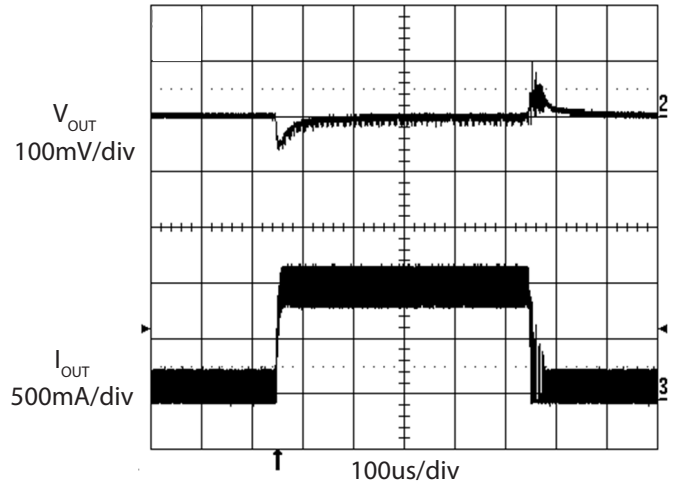

Figure 8. 100mA to 2A Load Step ( $V_{CC}=12\text{V}$ ,  $V_{OUT}=1.8\text{V}$ )

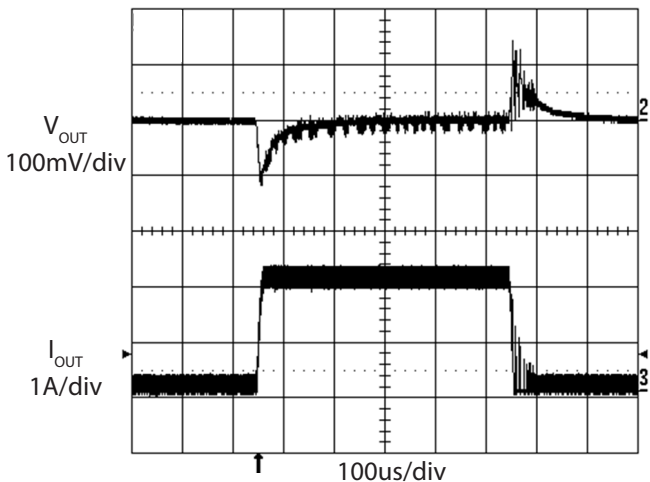
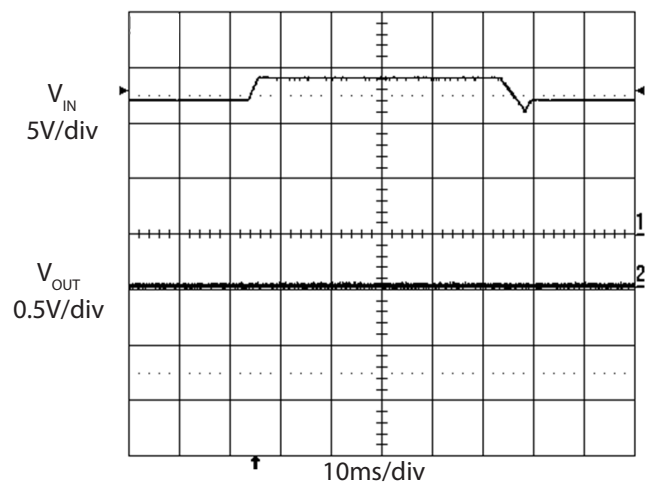

Figure 9. Line Transient Response ( $V_{CC}=12\text{V}$ ,  $V_{OUT}=3.3\text{V}$ )



# Typical Performance Characteristics continued (Subject to Change)

$T_J = -40^{\circ}\text{C}$  to  $125^{\circ}\text{C}$ ,  $V_{CC} = 12\text{V}$  (unless otherwise noted)

**Figure 10. Load Regulation**

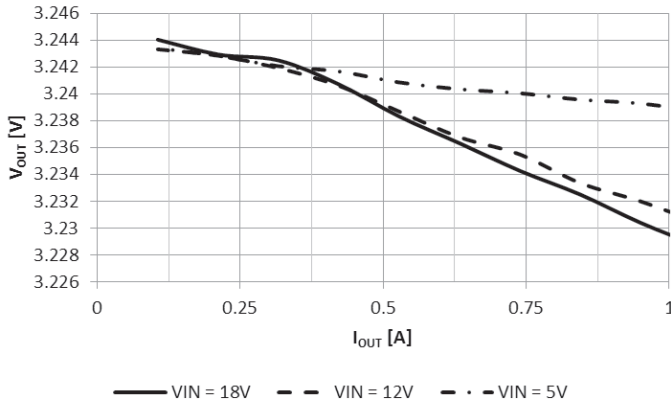

**Figure 11. Efficiency vs. Output Current ( $V_{OUT} = 3.3\text{V}$ )**

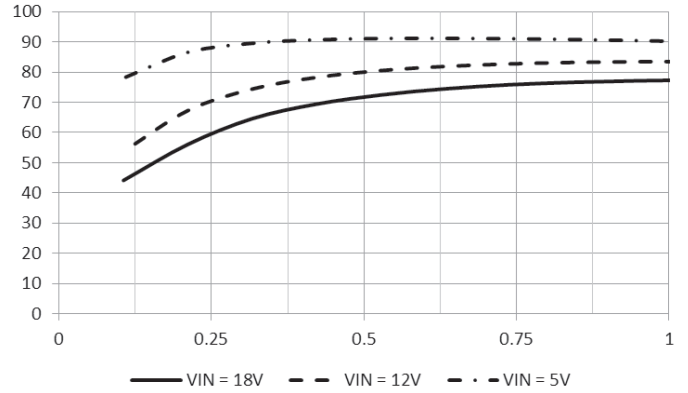

**Figure 12. Output Voltage vs. Ambient Temperature**

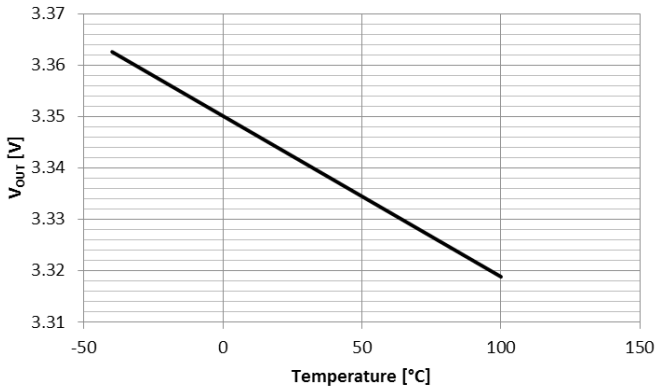

**Figure 13. Efficiency vs. Ambient Temperature ( $V_{OUT} = 3.3\text{V}$ )**

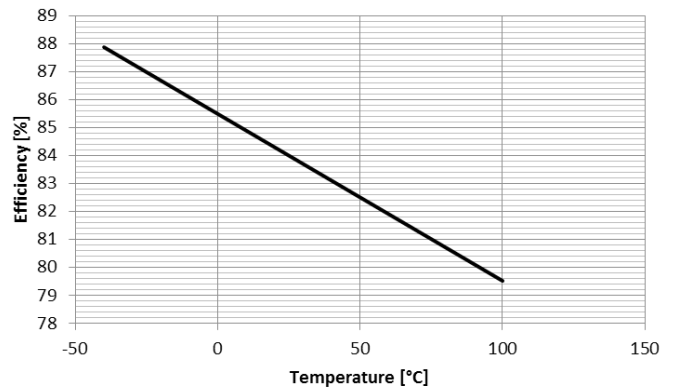

**Figure 14. Switching Frequency vs. Ambient Temperature**

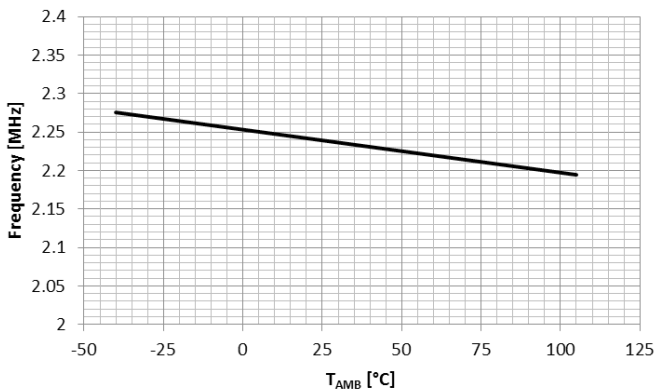



# Typical Performance Characteristics continued (Subject to Change)

$T_J = -40^{\circ}\text{C}$  to  $125^{\circ}\text{C}$ ,  $V_{CC} = 12\text{V}$  (unless otherwise noted)

Figure 15. Standby Current vs. Input Voltage

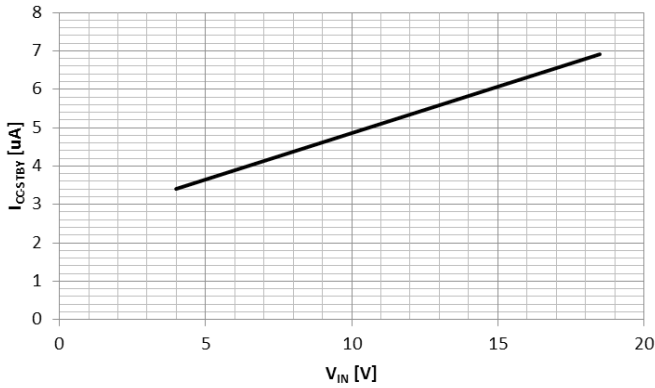

Figure 16. Standby Current vs. Ambient Temperature

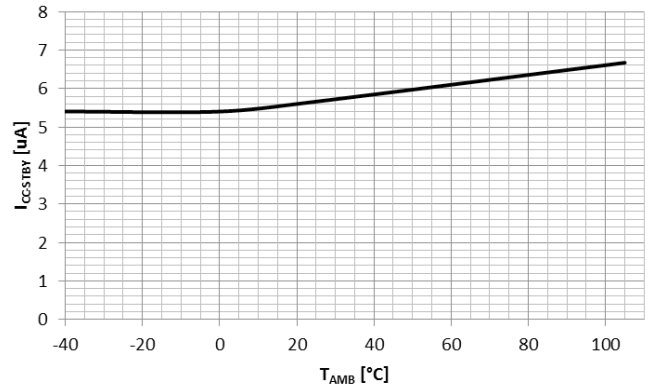

Figure 17. Quiescent Current vs. Input Voltage

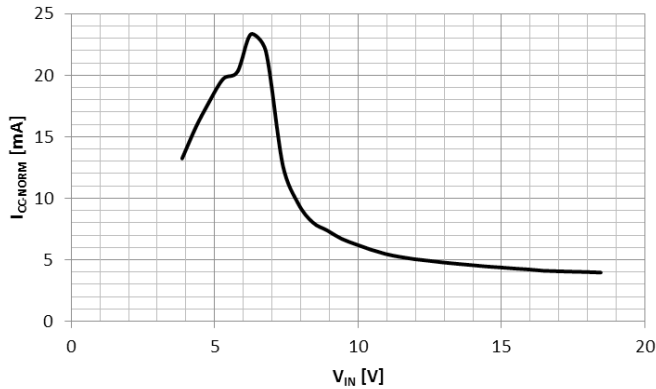

Figure 18. Quiescent Current vs. Ambient Temperature

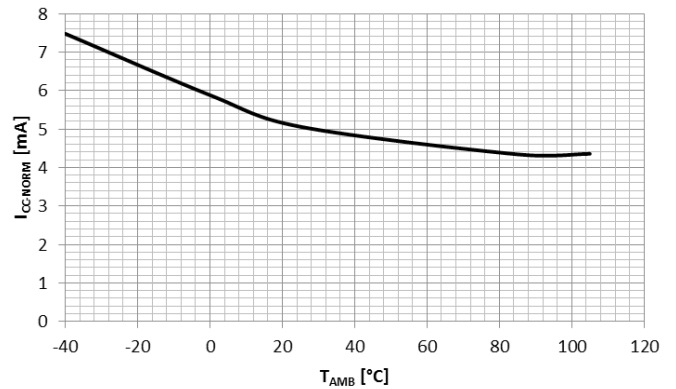

Figure 19. TS30041Q Output Current Derating Guideline  
 $V_{CC} = 18\text{V}$ ,  $V_{OUT} = 3.3\text{V}$

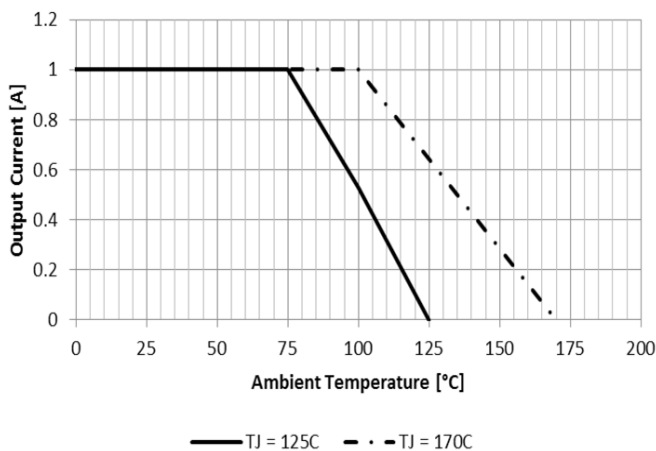
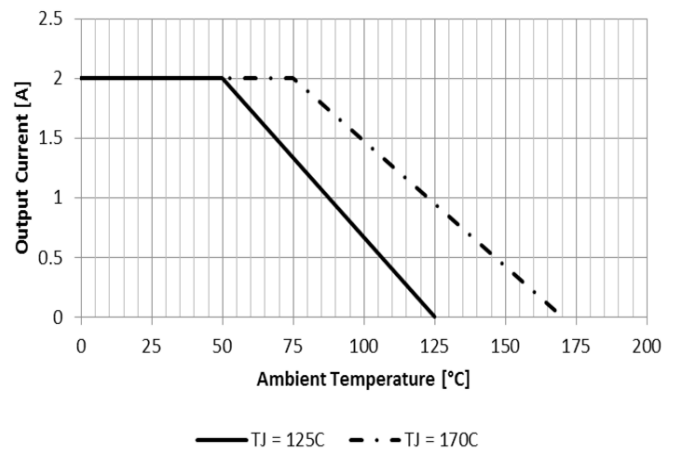

Figure 20. TS30042Q Output Current Derating Guideline  
 $V_{CC} = 18\text{V}$ ,  $V_{OUT} = 3.3\text{V}$



## Functional Description

The TS30041Q/42Q current-mode synchronous step-down power supply product is ideal for use in the commercial, industrial and automotive market segments. It includes flexibility to be used for a wide range of output voltages and is optimized for high efficiency power conversion with low  $R_{\text{DS(on)}}$  integrated synchronous switches. A 2.2MHz internal switching frequency facilitates low cost LC filter combinations. Additionally, the fixed output versions enable a minimum external component count to provide a complete regulation solution with only 4 external components: an input bypass capacitor, an inductor, an output capacitor, and the bootstrap capacitor. The regulator automatically transitions between PFM and PWM mode to maximize efficiency for the load demand.

The TS30041Q/42Q was designed to provide these system benefits:

- Reduced board real estate
- Lower system cost
  - ◆ Lower cost inductor
  - ◆ Low external parts count
- Ease of design
  - ◆ Bill of Materials and suggested board layout provided
  - ◆ Power Good output
  - ◆ Integrated compensation network
  - ◆ Wide input voltage range
- Robust solution
  - ◆ Over current, over voltage and over temperature protection

## Detailed Pin Description

### Unregulated input, VCC

This terminal is the unregulated input voltage source for the IC. It is recommended that a 10 $\mu$ F bypass capacitor be placed close to the device for best performance. Since this is the main supply for the IC, good layout practices need to be followed for this connection.

### Bootstrap control, BST

This terminal will provide the bootstrap voltage required for the upper internal NMOS switch of the buck regulator. An external ceramic capacitor placed between the BST input terminal and the VSW pin will provide the necessary voltage for the upper switch. In normal operation the capacitor is re-charged on every low side synchronous switching action. In the case of where the switch mode approaches 100% duty cycle for the high side FET, the device will automatically reduce the duty cycle switch to a minimum off time on every 16th cycle to allow this capacitor to re-charge.

### Sense feedback, FB

This is the input terminal for the output voltage feedback.

For the fixed mode versions, this should be hooked directly to VOUT. The connection on the PCB should be kept as short as possible, and should be made as close as possible to the capacitor. The trace should not be shared with any other connection. (Figure 22)

For adjustable mode versions, this should be connected to the external resistor divider. To choose the resistors, use the following equation:

$$V_{\text{OUT}} = 0.9V \left( 1 + \frac{R_{\text{TOP}}}{R_{\text{BOT}}} \right)$$

The input to the FB pin is high impedance, and input current should be less than 100nA. As a result, good layout practices are required for the feedback resistors and feedback traces. When using the adjustable version, the feedback trace should be kept as short as possible and minimum width to reduce stray capacitance and to reduce the injection of noise.

For the adjustable version, the ratio of  $V_{\text{CC}}/V_{\text{OUT}}$  cannot exceed 7.

### Switching output, VSW

This is the switching node of the regulator. It should be connected directly to the 4.7 $\mu$ H inductor with a wide, short trace and to one end of the Bootstrap capacitor. It is switching between  $V_{CC}$  and PGND at the switching frequency.

### Ground, GND

This ground is used for the majority of the device including the analog reference, control loop, and other circuits.

### Power Ground, PGND

This is a separate ground connection used for the low side synchronous switch to isolate switching noise from the rest of the device. (Figure 22)

### Enable/Synchronize, high-voltage, EN/SYNC

This is the input terminal to activate the regulator. The input threshold is TTL/CMOS compatible. It also has an internal pull-up to ensure a stable state if the pin is disconnected. After a sequence of three rising edge pulses having a frequency greater than or equal to FSync-Min, the switcher synchronizes to the frequency of the signal provided on the EN/SYNC pin. SYNC frequency range is tested with a square wave and a high pulse of minimum 200ns duration is required for proper operation. For higher frequencies of operation a 2.2 $\mu$ H inductor and for lower frequencies of operation a 10 $\mu$ H inductor is recommended.

### Power Good Output, PG

This is an open drain, active low output. The switched mode output voltage is monitored and the PG line will remain low until the output voltage reaches the  $V_{OUT-UV}$  threshold. Once the internal comparator detects the output voltage is above the desired threshold, an internal delay timer is activated and the PG line is de-asserted to high once this delay timer expires. In the event the output voltage decreases below  $V_{OUT-UV}$  the PG line will be asserted low and remain low until the output rises above  $V_{OUT-UV}$  and the delay timer times out. See Figure 3 for the circuit schematic for the PG signal.

## Internal Protection Details

### Internal Current Limit

The current through the high side FET is sensed on a cycle by cycle basis and if current limit is reached, it will abbreviate the cycle. In addition, the device senses the FB pin to identify hard short conditions and will direct the VSW output to skip 4 cycles if current limit occurs when FB is low. This allows current built up in the inductor during the minimum on time to decay sufficiently. Current limit is always active when the regulator is enabled. Soft start ensures current limit does not prevent regulator startup. Under extended over current conditions (such as a short), the device will automatically disable. Once the over current condition is removed, the device returns to normal operation automatically.

(Alternately the factory can configure the device's NVM to shut-down the regulator if an extended over current event is detected and require a toggle of the Enable pin to return the device to normal operation.)

### Thermal Shutdown

If the temperature of the die exceeds 170°C (typical), the VSW outputs will tristate to protect the device from damage. The PG and all other protection circuitry will stay active to inform the system of the failure mode. Once the device cools to 160°C (typical), the device will start up again, following the normal soft start sequence. If the device reaches 170°C, the shutdown/restart sequence will repeat.

### Output Current Derating Guideline

Figure 19 and 20 show the recommended output current derating based on ambient temperature. The solid line in the figure specifies the amount of current that will make the junction temperature rise to  $T_J = 125^\circ\text{C}$  and the dotted line is the amount of current that will cause the IC to enter Thermal Shutdown or  $T_J = 170^\circ\text{C}$ . Data shows worse case scenario for Semtech's EVB operating at full load with  $V_{CC} = 18\text{V}$  and 3.3V<sub>OUT</sub>. Results will vary depending on input voltage, output voltage, load current and system efficiency among others.

### Reference Soft Start

The reference in this device is ramped at a rate of 4ms to prevent the output from overshooting during startup. This ramp restarts whenever there is a rising edge sensed on the Enable pin. This occurs in both the fixed and adjustable versions. During the soft start ramp, current limit is still active, and will still protect the device in case of a short on the output.

### Output Overvoltage

If the output of the regulator exceeds 103% of the regulation voltage, the VSW outputs will tristate to protect the device from damage. This check occurs at the start of each switching cycle. If it occurs during the middle of a cycle, the switching for that cycle will complete, and the VSW outputs will tri-state at the beginning of the next cycle.

### VCC Under-Voltage Lockout

The device is held in the off state until  $V_{CC}$  reaches 4.3V (typical). There is a 350mV hysteresis on this input, which requires the input to fall below 4.0V (typical) before the device will disable.

### Transient Response

TS30041Q/42Q has been designed to work under a wide range of input and output voltages, supporting different values and types of output capacitance. By design, TS30041Q/42Q adjustable output version has lower bandwidth than fixed version. For adjustable output version designs, with a high slew rate load requirement using a 10nF feed-forward capacitor in parallel with the  $R_{TOP}$  feedback resistor is recommended.

## Typical Application Schematic

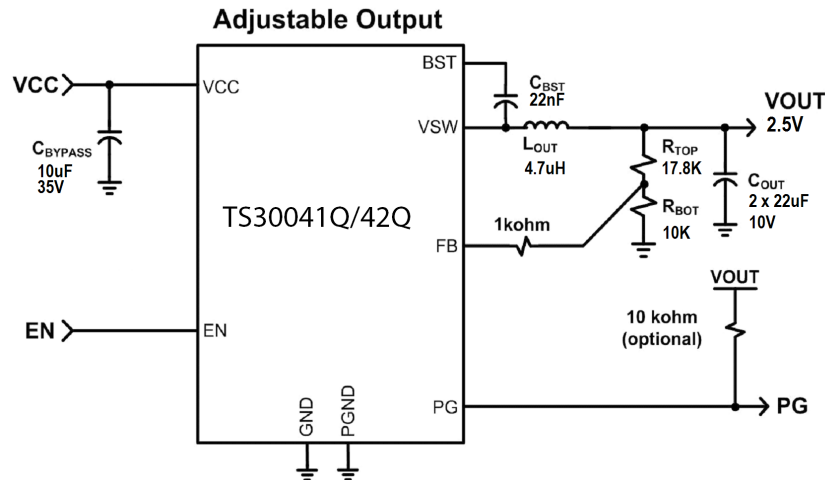

Figure 21: TS30041Q/42Q Application Schematic

A minimal schematic suitable for most applications is shown on page 1. Figure 21 includes optional components that may be considered to address specific issues as listed in the External Component Selection section.

## PCB Layout

For proper operation and minimum EMI, care must be taken during PCB layout. An improper layout can lead to issues such as poor stability and regulation, noise sensitivity and increased EMI radiation. (Figure 22) The main guidelines are the following:

- provide low inductive and resistive paths for loops with high  $di/dt$ ,
- provide low capacitive paths with respect to all the other nodes for traces with high  $di/dt$ ,
- sensitive nodes not assigned to power transmission should be referenced to the analog signal ground (GND) and be always separated from the power ground (PGND).

The negative ends of  $C_{BYPASS}$ ,  $C_{OUT}$  and the Schottky diode  $D_{CATCH}$  (optional) should be placed close to each other and connected using a wide trace. Vias must be used to connect the PGND node to the ground plane. The PGND node must be placed as close as possible to the TS30041Q/42Q PGND pins to avoid additional voltage drop in traces.

The bypass capacitor  $C_{BYPASS}$  (optionally paralleled to a 0.1µF capacitor) must be placed close to the  $V_{CC}$  pins of TS30041Q/42Q.

The inductor must be placed close to the VSW pins and connected directly to  $C_{OUT}$  in order to minimize the area between the VSW pin, the inductor, the  $C_{OUT}$  capacitor and the PGND pins. The trace area and length of the switching nodes VSW and BST should be minimized.

For the adjustable output voltage version of the TS30041Q/42Q, feedback resistors  $R_{BOT}$  and  $R_{TOP}$  are required for  $V_{OUT}$  settings greater than 0.9V and should be placed close to the TS30041Q/42Q in order to keep the traces of the sensitive node FB as short as possible and away from switching signals.  $R_{BOT}$  should be connected to the analog ground pin (GND) directly and should never be connected to the ground plane. The analog ground trace (GND) should be connected in only one point to the power ground (PGND). A good connection point is under the TS30041Q/42Q package to the exposed thermal pad and vias which are connected to PGND.  $R_{TOP}$  will be connected to the  $V_{OUT}$  node using a trace that ends close to the actual load.

For fixed output voltage versions of the TS30041Q/42Q,  $R_{BOT}$  and  $R_{TOP}$  are not required and the FB pin should be connected directly to the Vout.

The exposed thermal pad must be soldered to the PCB for mechanical reliability and to achieve good power dissipation. Vias must be placed under the pad to transfer the heat to the ground plane.

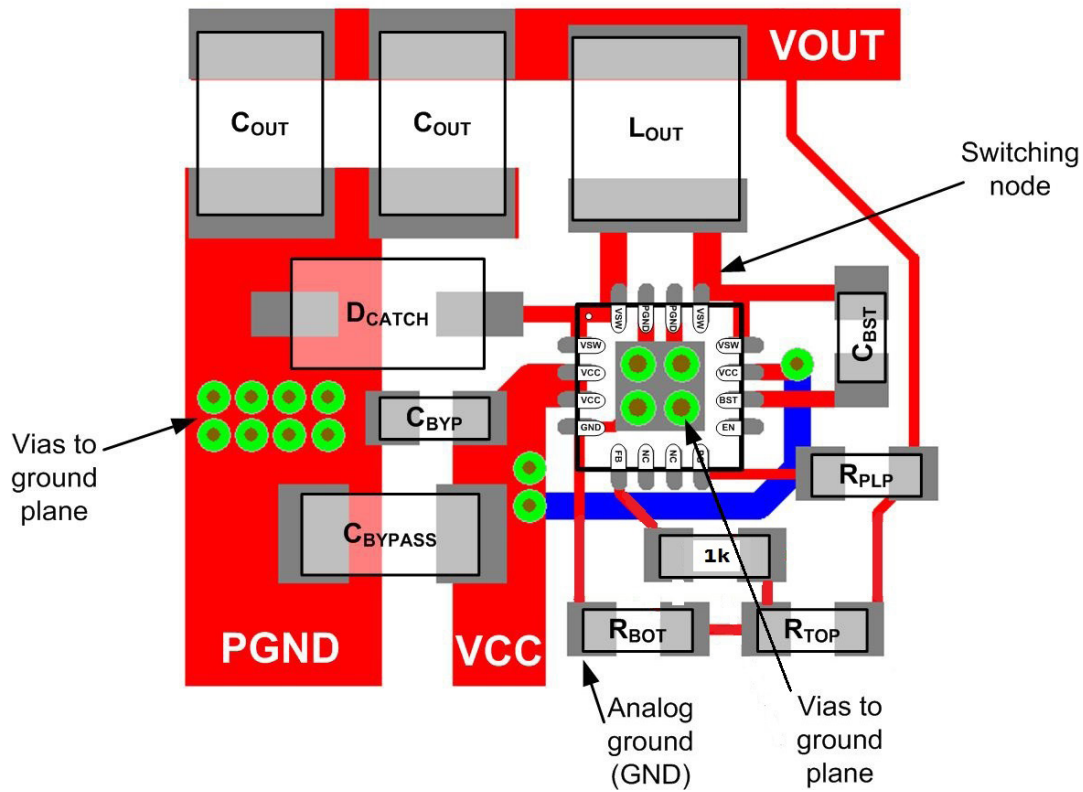

Figure 22: TS30041Q/42Q PCB Layout, Top View

## External Component Bill of Material

Designator	Function	Description	Suggested Manufacturer	Manufacturer Code	Qty
C <sub>BYPASS</sub>	Input Supply Bypass Capacitor	10 $\mu$ F $\pm$ 10% 50V			1
C <sub>OUT</sub>	Output Filter Capacitor	22 $\mu$ F $\pm$ 10% 10V	TDK Wurth	C2012X5R1A226K125AB 885 012 208 019	2
L <sub>OUT</sub>	Output Filter Inductor (1A)	4.7 $\mu$ H 2A	TDK	SLF7045T-4R7M2R0-PF 7447745047	
L <sub>OUT</sub>	Output Filter Inductor (2A)	4.7 $\mu$ H 3A	TDK Wurth	VLC5045T-4R7M 744774047	1
C <sub>BST</sub>	Boost Capacitor	22nF 10V	TDK Wurth	C1005X7R1C223K 885 012 205 033	1
R <sub>TOP</sub>	Voltage Feedback Resistor (optional)	17.8K (Note 1)			1
R <sub>BOT</sub>	Voltage Feedback Resistor (optional)	10K (Note 1)			1
R <sub>PLP</sub>	PG Pin Pull-up Resistor (optional)	10K			1
D <sub>CATCH</sub>	Catch Diode (optional, 1A)	60V 2A SOD-123	Fairchild semiconductor	SS25FA	1
D <sub>CATCH</sub>	Catch Diode (optional, 2A)	60V 3A SOD-123	Fairchild semiconductor	SS36FA	1

Note 1: The voltage divider resistor values are calculated for an output voltage of 2.5V. For fixed output versions, the FB pin is connected directly to V<sub>OUT</sub>.

---

## External Component Selection

The 2.2MHz internal switching frequency of the TS30041Q/42Q facilitates low cost LC filter combinations. Additionally, the fixed output versions enable a minimum external component count to provide a complete regulation solution with only 4 external components: an input bypass capacitor, an inductor, an output capacitor, and the bootstrap capacitor. The internal compensation is optimized for a 44µF output capacitor and a 4.7µH inductor.

For best performance, a low ESR ceramic capacitor should be used for  $C_{\text{BYPASS}}$ . If  $C_{\text{BYPASS}}$  is not a low ESR ceramic capacitor, a 0.1µF ceramic capacitor should be added in parallel to  $C_{\text{BYPASS}}$ .

The minimum allowable value for the output capacitor is 33µF. To keep the output ripple low, a low ESR (less than 35mOhm) ceramic is recommended. Multiple capacitors can be paralleled to reduce the ESR.

The inductor range is 4.7µH ±20%. For optimal over-current protection, the inductor should be able to handle up to the regulator current limit without saturation. Otherwise, an inductor with a saturation current rating higher than the maximum  $I_{\text{OUT}}$  load requirement plus the inductor current ripple should be used.

For high current modes, the optional Schottky diode will improve the overall efficiency and reduce the heat. It is up to the user to determine the cost/benefit of adding this additional component in the user's application. The diode is typically not needed.

For the adjustable output version of the TS30041Q/42Q, the output voltage can be adjusted by sizing  $R_{\text{TOP}}$  and  $R_{\text{BOT}}$  feedback resistors. The equation for the output voltage is:

$$V_{\text{OUT}} = 0.9V \left( 1 + \frac{R_{\text{TOP}}}{R_{\text{BOT}}} \right)$$

For the adjustable version, the ratio of  $V_{\text{CC}}/V_{\text{OUT}}$  cannot exceed 7.

$R_{\text{PUP}}$  is only required when the Power Good signal (PG) is utilized.

## Thermal Information

TS30041Q/42Q is designed for a maximum operating junction temperature  $T_j$  of 125°C. The maximum output power is limited by the power losses that can be dissipated over the thermal resistance given by the package and the PCB structures. The PCB must provide heat sinking to keep the TS30041Q/42Q cool. The exposed metal on the bottom of the QFN package must be soldered to a ground plane. This ground should be tied to other copper layers below with thermal vias. Adding more copper to the top and the bottom layers and tying this copper to the internal planes with vias can reduce thermal resistance further. For a hi-K JEDEC board and 13.5 square inch of 1 oz Cu, the thermal resistance from junction to ambient can be reduced to  $\theta_{\text{JA}} = 34.5^\circ\text{C}/\text{W}$ . The power dissipation of other power components (catch diode, inductor) cause additional copper heating and can further increase what the TS30041Q/42Q sees as ambient temperature.

# Package Mechanical Drawings (all dimensions in mm)

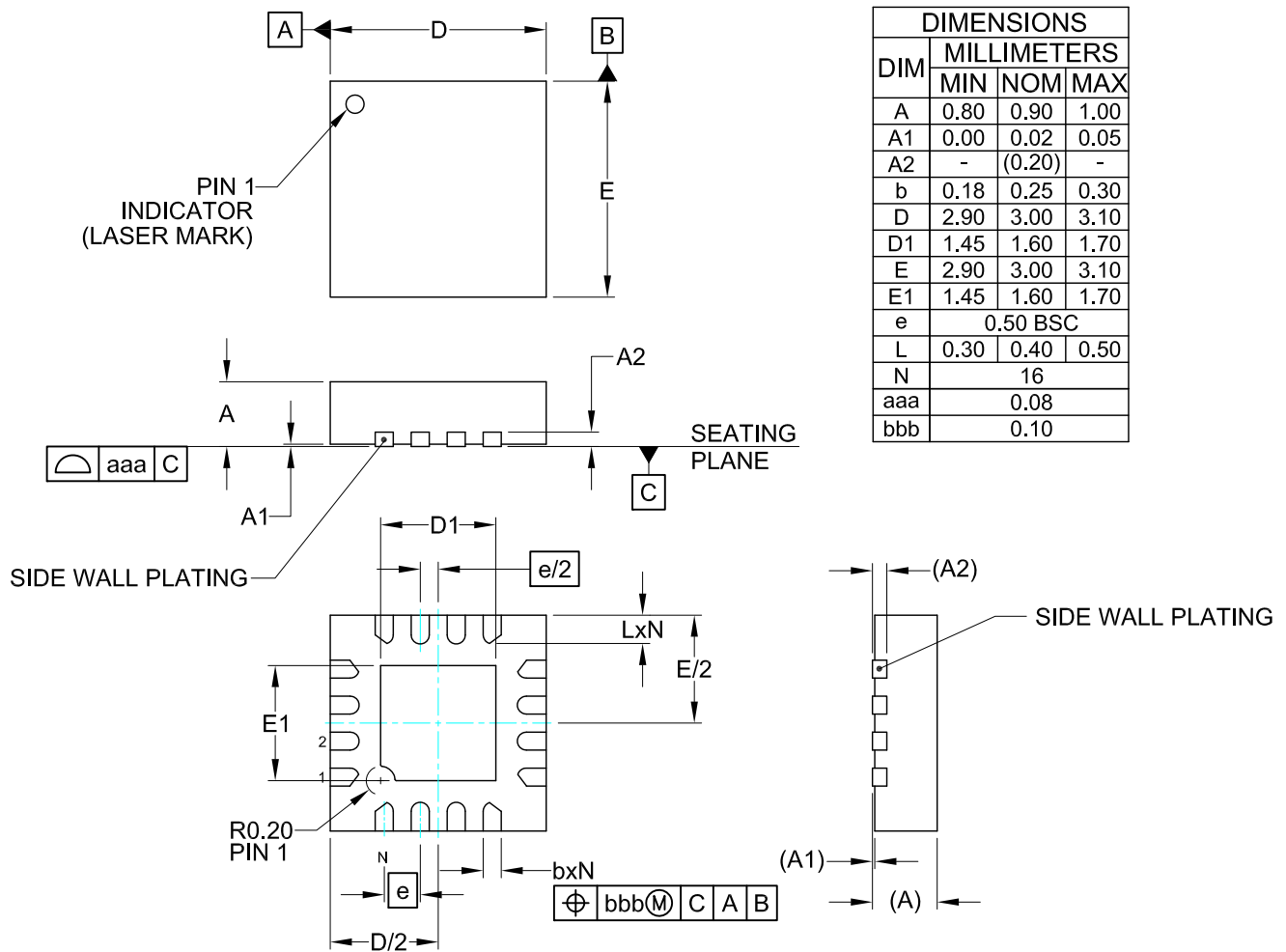

**NOTES:**

1. CONTROLLING DIMENSIONS ARE IN MILLIMETERS (ANGLES IN DEGREES).
2. COPLANARITY APPLIES TO THE EXPOSED PAD AS WELL AS THE TERMINALS.

## Recommended PCB Land Pattern

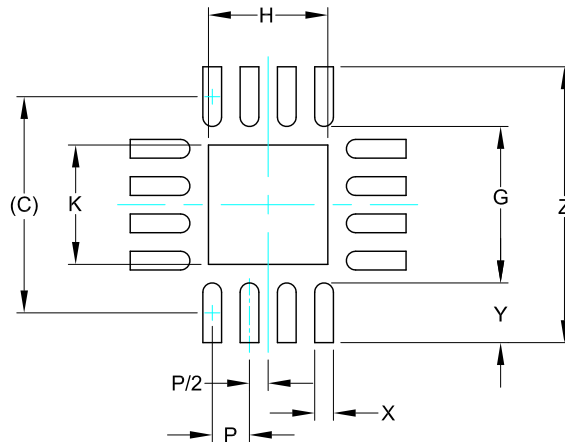

DIMENSIONS	
DIM	MILLIMETERS
C	(2.90)
G	2.10
H	1.60
K	1.60
P	0.50
X	0.25
Y	0.80
Z	3.70

### NOTES:

1. CONTROLLING DIMENSIONS ARE IN MILLIMETERS (ANGLES IN DEGREES).
2. THIS LAND PATTERN IS FOR REFERENCE PURPOSES ONLY. CONSULT YOUR MANUFACTURING GROUP TO ENSURE YOUR COMPANY'S MANUFACTURING GUIDELINES ARE MET.
3. THERMAL VIAS IN THE LAND PATTERN OF THE EXPOSED PAD SHALL BE CONNECTED TO A SYSTEM GROUND PLANE. FAILURE TO DO SO MAY COMPROMISE THE THERMAL AND/OR FUNCTIONAL PERFORMANCE OF THE DEVICE.



## Marking and Ordering Information



Part Number	Voltage Assign	Marking Code
TS30041Q-M000QFNR	ADJ V	41Q00
TS30041Q-M033QFNR	3.3 V	41Q33

Tape & Reel (3300 parts/reel)

Note: For additional Fixed Output Voltage Options, contact Semtech marketing.



Part Number	Voltage Assign	Marking Code
TS30042Q-M000QFNR	ADJ V	42Q00
TS30042Q-M025QFNR	2.5 V	42Q25

Tape & Reel (3300 parts/reel)

Note: For additional Fixed Output Voltage Options, contact Semtech marketing.



---

#### IMPORTANT NOTICE

Information relating to this product and the application or design described herein is believed to be reliable, however such information is provided as a guide only and Semtech assumes no liability for any errors in this document, or for the application or design described herein. Semtech reserves the right to make changes to the product or this document at any time without notice. Buyers should obtain the latest relevant information before placing orders and should verify that such information is current and complete. Semtech warrants performance of its products to the specifications applicable at the time of sale, and all sales are made in accordance with Semtech's standard terms and conditions of sale.

SEMTECH PRODUCTS ARE NOT DESIGNED, INTENDED, AUTHORIZED OR WARRANTED TO BE SUITABLE FOR USE IN LIFE-SUPPORT APPLICATIONS, DEVICES OR SYSTEMS, OR IN NUCLEAR APPLICATIONS IN WHICH THE FAILURE COULD BE REASONABLY EXPECTED TO RESULT IN PERSONAL INJURY, LOSS OF LIFE OR SEVERE PROPERTY OR ENVIRONMENTAL DAMAGE. INCLUSION OF SEMTECH PRODUCTS IN SUCH APPLICATIONS IS UNDERSTOOD TO BE UNDERTAKEN SOLELY AT THE CUSTOMER'S OWN RISK. Should a customer purchase or use Semtech products for any such unauthorized application, the customer shall indemnify and hold Semtech and its officers, employees, subsidiaries, affiliates, and distributors harmless against all claims, costs damages and attorney fees which could arise.

The Semtech name and logo are registered trademarks of the Semtech Corporation. All other trademarks and trade names mentioned may be marks and names of Semtech or their respective companies. Semtech reserves the right to make changes to, or discontinue any products described in this document without further notice. Semtech makes no warranty, representation or guarantee, express or implied, regarding the suitability of its products for any particular purpose. All rights reserved.

© Semtech 2016

---

#### Contact Information

Semtech Corporation  
200 Flynn Road, Camarillo, CA 93012  
Phone: (805) 498-2111, Fax: (805) 498-3804  
[www.semtech.com](http://www.semtech.com)

## X-ON Electronics

Largest Supplier of Electrical and Electronic Components

*Click to view similar products for [Switching Voltage Regulators](#) category:*

*Click to view products by [Semtech](#) manufacturer:*

Other Similar products are found below :

[FAN53610AUC33X](#) [FAN53611AUC123X](#) [FAN48610BUC33X](#) [FAN48610BUC45X](#) [FAN48617UC50X](#) [R3](#) [430464BB](#) [KE177614](#)  
[FAN53611AUC12X](#) [MAX809TTR](#) [NCV891234MW50R2G](#) [NCP81103MNTXG](#) [NCP81203PMNTXG](#) [NCP81208MNTXG](#)  
[NCP81109GMNTXG](#) [SCY1751FCCT1G](#) [NCP81109JMNTXG](#) [AP3409ADNTR-G1](#) [NCP81241MNTXG](#) [LTM8064IY](#) [LT8315EFE#TRPBF](#)  
[LTM4664EY#PBF](#) [LTM4668AIY#PBF](#) [NCV1077CSTBT3G](#) [XCL207A123CR-G](#) [MPM54304GMN-0002](#) [MPM54304GMN-0004](#)  
[MPM54304GMN-0003](#) [AP62300Z6-7](#) [MP8757GL-P](#) [MIC23356YFT-TR](#) [LD8116CGL](#) [HG2269M/TR](#) [OB2269](#) [XD3526](#) [U6215A](#) [U6215B](#)  
[U6620S](#) [LTC3412IFE](#) [LT1425IS](#) [MAX25203BATJA/VY+](#) [MAX77874CEWM+](#) [XC9236D08CER-G](#) [MP3416GJ-P](#) [BD9S201NUX-CE2](#)  
[MP5461GC-Z](#) [MPQ4415AGQB-Z](#) [MPQ4590GS-Z](#) [MAX38640BENT18+T](#) [MAX77511AEWB+](#)