

PROTECTION PRODUCTS - MicroClamp™

Description

The μClamp™ series of TVS arrays are designed to protect sensitive electronics from damage or latch-up due to ESD. They are designed for use in applications where board space is at a premium. Each device requires less than 2.6mm² of PCB area and will protect up to six lines. TVS diodes are solid-state devices designed specifically for transient suppression. They feature large cross-sectional area junctions for conducting high transient currents. They offer desirable characteristics for board level protection including fast response time, low operating and clamping voltage, and no device degradation.

The uClamp0506P is in a 6-pin, RoHS/WEEE compliant, SLP1616P6 package. It measures 1.6 x 1.6 x 0.60mm. The leads are spaced at a pitch of 0.5mm and are finished with lead-free NiPdAu. They may be used to meet the ESD immunity requirements of IEC 61000-4-2, Level 4 (±15kV air, ±8kV contact discharge). The combination of small size, low capacitance, and high ESD surge capability makes them ideal for use in portable electronics such as cell phones, PDAs, notebook computers, and digital cameras.

Features

- ◆ Transient protection for data lines to **IEC 61000-4-2 (ESD) ±15kV (air), ±8kV (contact) IEC 61000-4-4 (EFT) 40A (5/50ns)**
- ◆ Protects six I/O lines
- ◆ Ultra-small package (**1.6 x 1.6 x 0.6mm**) requires less than 2.6mm² of PCB area
- ◆ Working voltage: 5V
- ◆ Low leakage current
- ◆ Low operating and clamping voltages
- ◆ Solid-state silicon-avalanche technology

Mechanical Characteristics

- ◆ SLP1616P6 6L package
- ◆ RoHS/WEEE Compliant
- ◆ Nominal Dimensions: 1.6 x 1.6 x 0.60 mm
- ◆ Lead Finish: NiPdAu
- ◆ Molding compound flammability rating: UL 94V-0
- ◆ Marking: 0506P
- ◆ Packaging: Tape and Reel per EIA 481

Applications

- ◆ Cellular Handsets and Accessories
- ◆ Cordless Phones
- ◆ Personal Digital Assistants (PDAs)
- ◆ Portable Instrumentation
- ◆ Digital Cameras
- ◆ Peripherals
- ◆ MP3 Players

Circuit Diagram

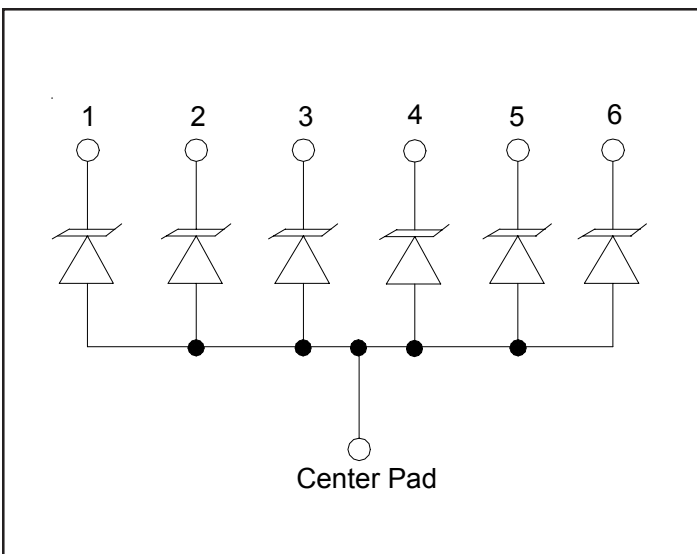

PIN Configuration

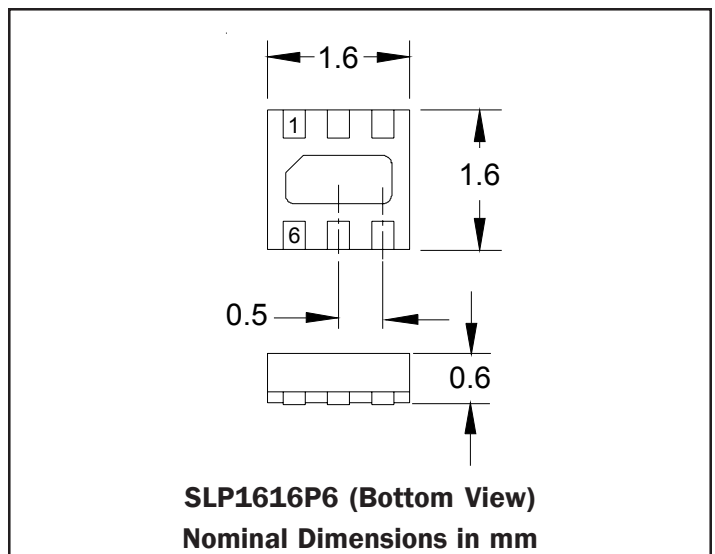

PROTECTION PRODUCTS
Absolute Maximum Rating

Rating	Symbol	Value	Units
Peak Pulse Power (tp = 8/20μs)	P_{pk}	100	Watts
Maximum Peak Pulse Current (tp = 8/20μs)	I_{pp}	7	Amps
ESD per IEC 61000-4-2 (Air) ESD per IEC 61000-4-2 (Contact)	V_{pp}	+/- 20 +/- 12	kV
Lead Soldering Temperature	T_L	260 (10 sec.)	°C
Operating Temperature	T_J	-55 to +125	°C
Storage Temperature	T_{STG}	-55 to +150	°C

Electrical Characteristics (T=25°C)

Parameter	Symbol	Conditions	Minimum	Typical	Maximum	Units
Reverse Stand-Off Voltage	V_{RWM}				5	V
Reverse Breakdown Voltage	V_{BR}	$I_t = 1mA$	6			V
Reverse Leakage Current	I_R	$V_{RWM} = 5V, T=25°C$			1	μA
Reverse Leakage Current	I_R	$V_{RWM} = 3V, T=25°C$			0.500	μA
Clamping Voltage	V_C	$I_{pp} = 1A, t_d = 8/20μs$ Any I/O to Ground Pad			9	V
Clamping Voltage	V_C	$I_{pp} = 1A, t_d = 8/20μs$ I/O to I/O			10	V
Clamping Voltage	V_C	$I_{pp} = 7A, t_d = 8/20μs$ Any I/O to Ground Pad			11	V
Clamping Voltage	V_C	$I_{pp} = 7A, t_d = 8/20μs$ I/O to I/O			12	V
Junction Capacitance	C_j	Between I/O Pins and Gnd $V_R = 0V, f = 1MHz$		60	75	pF
Junction Capacitance	C_j	Between I/O Pins and I/O Pins $V_R = 0V, f = 1MHz$		30	40	pF

PROTECTION PRODUCTS

Typical Characteristics

Non-Repetitive Peak Pulse Power vs. Pulse Time

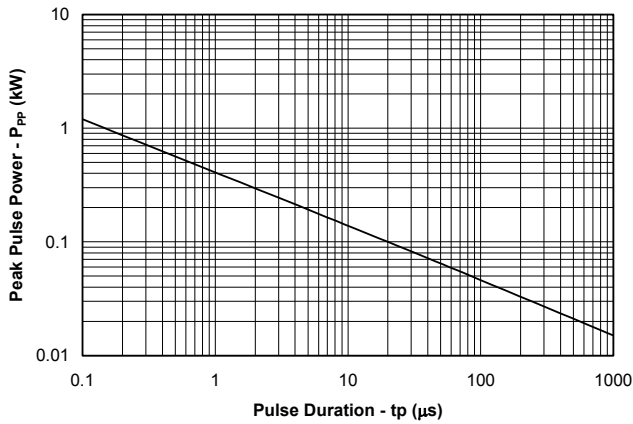

Power Derating Curve

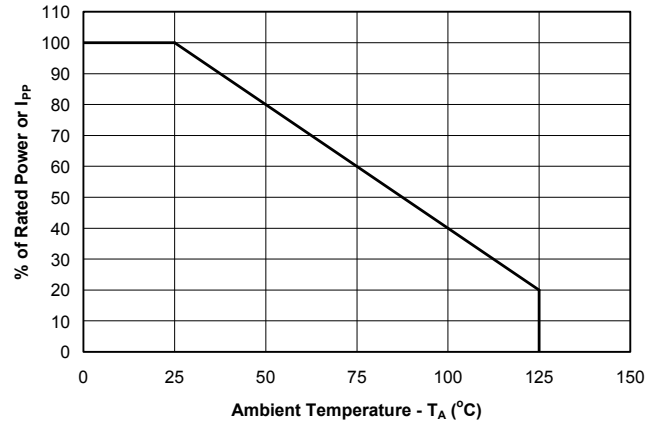

Clamping Voltage vs. Peak Pulse Current

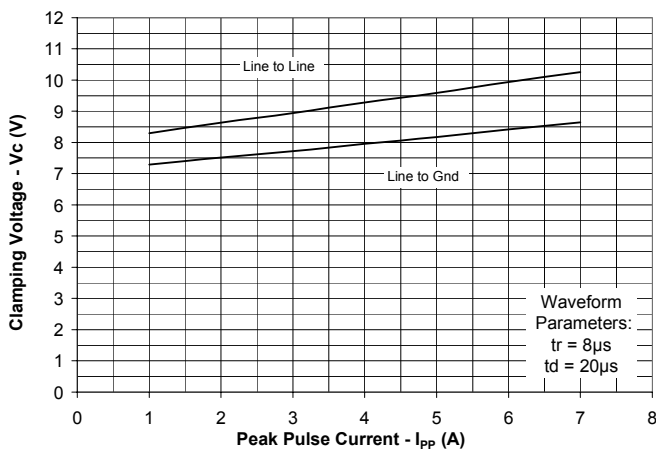

Forward Voltage vs. Peak Pulse Current

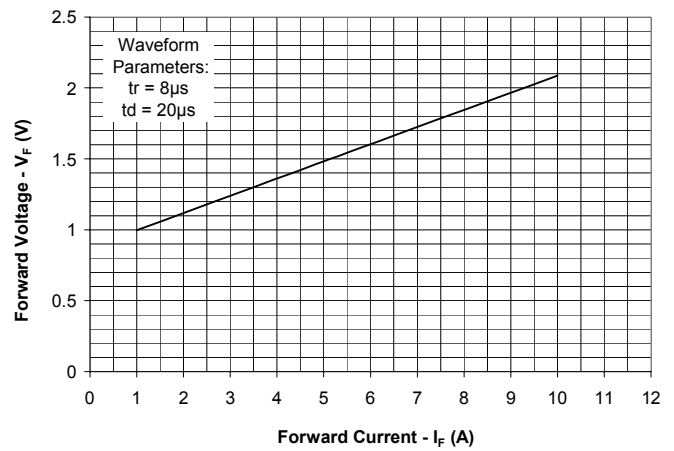

Normalized Capacitance vs. Reverse Voltage

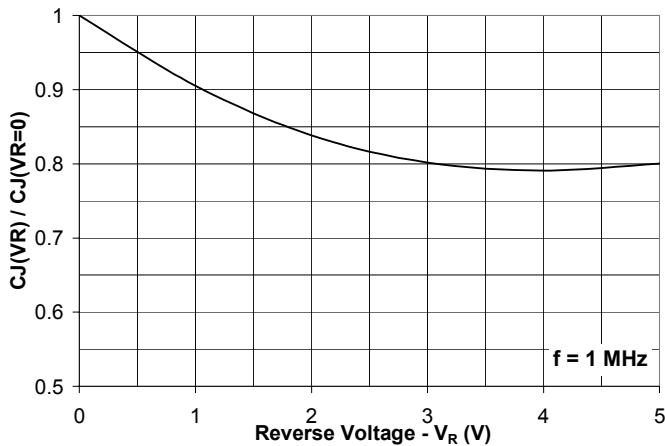

ESD Clamping (+8kV Contact per IEC 61000-4-2)

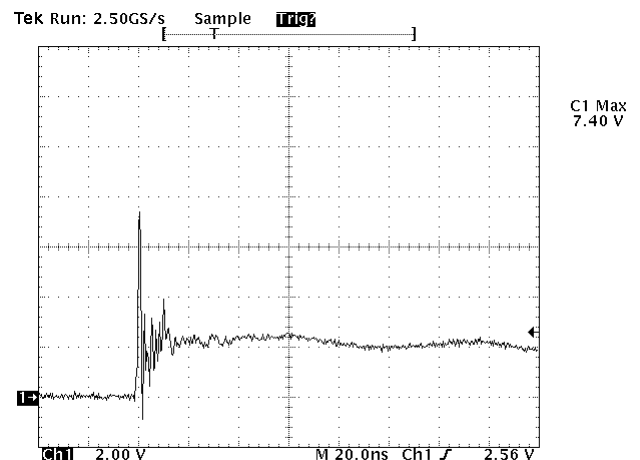

Note: Data is taken with a 10x attenuator

**ESD Clamping
(-8kV Contact per IEC 61000-4-2)**

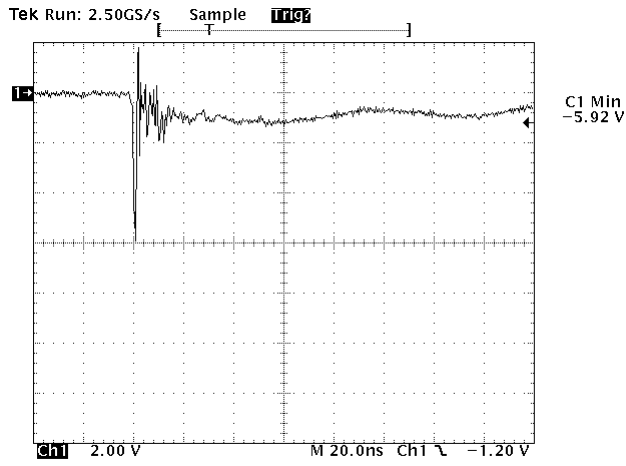

Note: Data is taken with a 10x attenuator

PROTECTION PRODUCTS

Applications Information

Device Connection for Protection of Five Data Lines

These devices can be configured to protect up to 6 unidirectional data lines or 5 bidirectional lines. The device is connected as follows:

1. Protection of six I/O lines is achieved by connecting pins 1, 2, 3, 4, 5, and 6 to the data lines. The center tab is connected to ground. The ground connection should be made directly to the ground plane for best results. The path length is kept as short as possible to reduce the effects of parasitic inductance in the board traces.
2. Bidirectional protection of five I/O lines is achieved by connecting and five pins data lines. The remaining pin is connected to ground. The center pad is not connected. The ground connection should be made directly to the ground plane for best results. The path length is kept as short as possible to reduce the effects of parasitic inductance in the board traces.

Circuit Board Layout Recommendations for Suppression of ESD.

Good circuit board layout is critical for the suppression of ESD induced transients. The following guidelines are recommended:

- Place the TVS near the input terminals or connectors to restrict transient coupling.
- Minimize the path length between the TVS and the protected line.
- Minimize all conductive loops including power and ground loops.
- The ESD transient return path to ground should be kept as short as possible.
- Never run critical signals near board edges.
- Use ground planes whenever possible.

Circuit Diagram

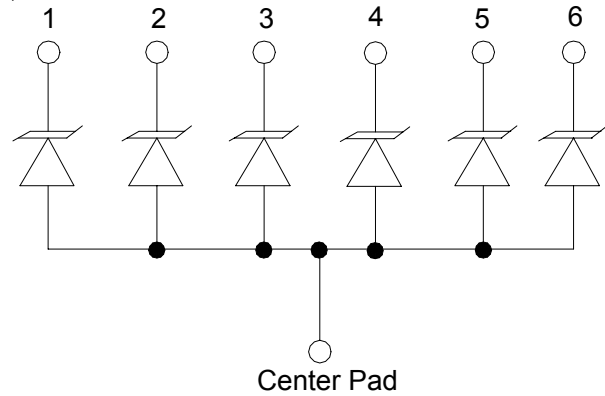

Pin Configuration (Top Side View)

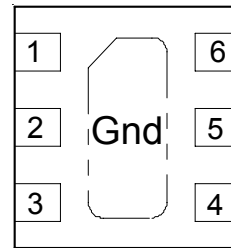

Pin	Identification
1, 2, 3, 4, 5, 6	Input/Output Lines
Center Tab	Ground

PROTECTION PRODUCTS

Applications Information - Spice Model

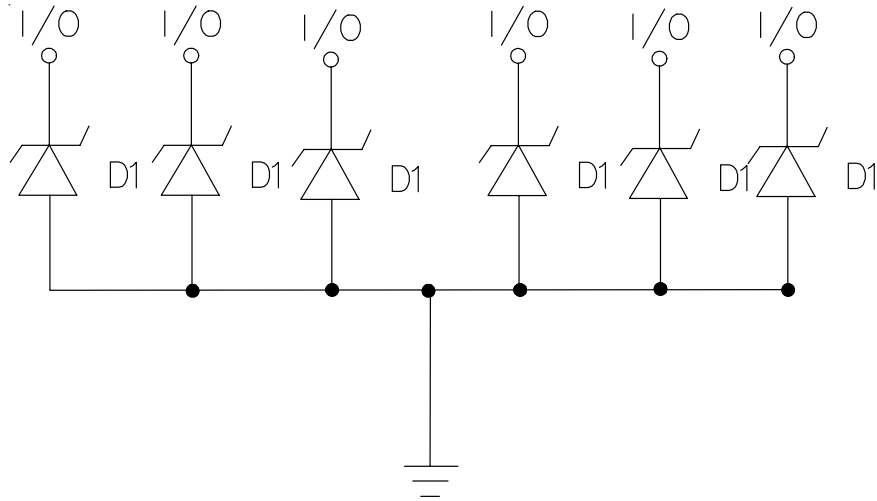

uClamp0506P Spice Model

Table 1 - uClamp0506P Spice Parameters

Parameter	Unit	D1 (TVS)
IS	Amp	7.82E-15
BV	Volt	7.03
VJ	Volt	0.73
RS	Ohm	0.211
IBV	Amp	1.0E-3
CJO	Farad	59E-12
TT	sec	2.541E-9
M	--	0.25
N	--	1.1
EG	eV	1.11

PROTECTION PRODUCTS

Outline Drawing - SLP1616P6

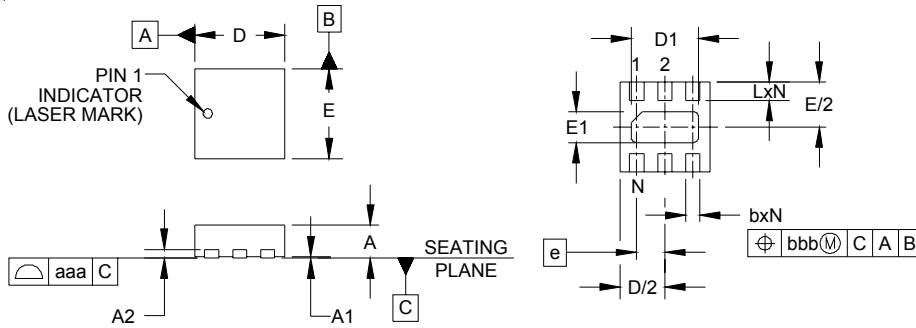

DIM	DIMENSIONS					
	INCHES			MILLIMETERS		
	MIN	NOM	MAX	MIN	NOM	MAX
A	.020	.023	.026	0.50	0.58	0.65
A1	0.00	.001	.002	0.00	0.03	0.05
A2		(.006)			(0.15)	
b	.007	.010	.012	0.20	0.25	0.30
D	.059	.063	.067	1.50	1.60	1.70
D1	.041	.047	.051	1.05	1.20	1.30
E	.059	.063	.067	1.50	1.60	1.70
E1	.010	.016	.020	0.25	0.40	0.50
e		.020 BSC			0.50 BSC	
L	.013	.013	.016	0.25	0.33	0.40
N		6			6	
aaa		.003			0.08	
bbb		.004			0.10	

NOTES:

1. CONTROLLING DIMENSIONS ARE IN MILLIMETERS (ANGLES IN DEGREES).
2. COPLANARITY APPLIES TO THE EXPOSED PAD AS WELL AS THE TERMINALS.

Land Pattern - SLP1616P6

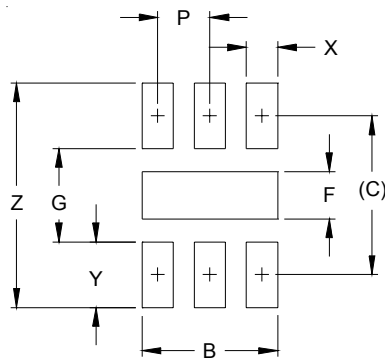

DIM	DIMENSIONS	
	INCHES	MILLIMETERS
B	.051	1.30
C	.060	1.52
P	.020	0.50
F	.018	0.45
G	.035	0.89
X	.012	0.30
Y	.025	0.63
Z	.085	2.15

NOTES:

1. THIS LAND PATTERN IS FOR REFERENCE PURPOSES ONLY. CONSULT YOUR MANUFACTURING GROUP TO ENSURE YOUR COMPANY'S MANUFACTURING GUIDELINES ARE MET

PROTECTION PRODUCTS

Marking Code

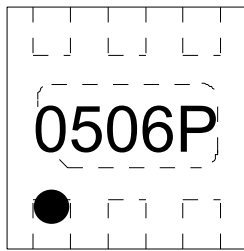

Ordering Information

Part Number	Lead Finish	Qty per Reel	Reel Size
uClamp0506P.TCT	Pb Free	3,000	7 Inch

MicroClamp and uClamp are marks of Semtech Corporation

Tape and Reel Specification

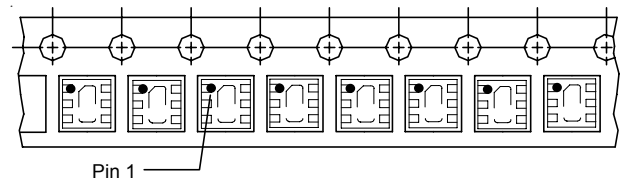
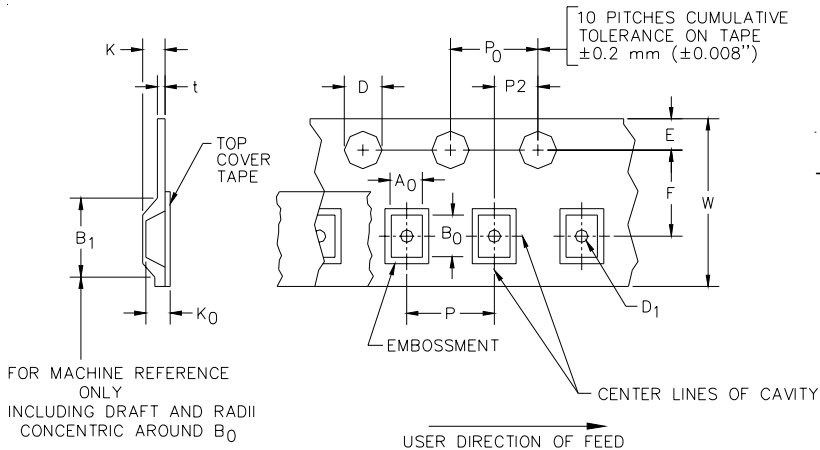

Device Orientation in Tape

A0	B0	K0
1.78 +/-0.05 mm	1.78 +/-0.05 mm	0.69 +/-0.05 mm

Tape Width	B, (Max)	D	D1	E	F	K (MAX)	P	P0	P2	T(MAX)	W
8 mm	4.2 mm	1.5 + 0.1 mm - 0.0 mm)	0.5 mm ±0.05	1.750±.10 mm	3.5±0.05 mm	2.4 mm	4.0±0.1 mm	4.0±0.1 mm	2.0±0.05 mm	0.4 mm	8.0 mm + 0.3 mm - 0.1 mm

Contact Information

Semtech Corporation
 Protection Products Division
 200 Flynn Rd., Camarillo, CA 93012
 Phone: (805)498-2111 FAX (805)498-3804

X-ON Electronics

Largest Supplier of Electrical and Electronic Components

Click to view similar products for [ESD Suppressors / TVS Diodes](#) category:

Click to view products by [Semtech](#) manufacturer:

Other Similar products are found below :

[60KS200C](#) [D12V0H1U2WS-7](#) [D18V0L1B2LP-7B](#) [82356050220](#) [D5V0M5U6V-7](#) [NTE4902](#) [P4KE27CA](#) [P6KE11CA](#) [P6KE39CA-TP](#)
[P6KE8.2A](#) [SA110CA](#) [SA60CA](#) [SA64CA](#) [SMBJ12CATR](#) [SMBJ8.0A](#) [SMLJ30CA-TP](#) [ESD101-B1-02ELS E6327](#) [ESD112-B1-02EL E6327](#)
[ESD119B1W01005E6327XTSA1](#) [ESD5V0L1B02VH6327XTSA1](#) [ESD7451N2T5G](#) [19180-510](#) [CPDT-5V0USP-HF](#) [3.0SMCJ33CA-F](#)
[3.0SMCJ36A-F](#) [HSPC16701B02TP](#) [D3V3Q1B2DLP3-7](#) [D55V0M1B2WS-7](#) [DESD5V0U1BL-7B](#) [DRTR5V0U4SL-7](#) [SCM1293A-04SO](#)
[ESD200-B1-CSP0201 E6327](#) [ESD203-B1-02EL E6327](#) [SM12-7](#) [SMF8.0A-TP](#) [SMLJ45CA-TP](#) [CEN955 W/DATA](#) [82350120560](#)
[82356240030](#) [VESD12A1A-HD1-GS08](#) [CPDUR5V0R-HF](#) [CPDUR24V-HF](#) [CPDQC5V0U-HF](#) [CPDQC5V0USP-HF](#) [CPDQC5V0-HF](#)
[D1213A-01LP4-7B](#) [D1213A-02WL-7](#) [ESDLIN1524BJ-HQ](#) [5KP100A](#) [5KP15A](#)