



## E25 | INCREMENTAL OPTICAL ENCODER



### Introduction

The E25 has been designed as a light duty encoder for applications such as robotics, precision computer peripherals and OEM motors and controls. It is designed with an integrated mounting ring and shaft coupling. The integrated mounting ring and shaft coupling allow for simplified installation and a low overall profile when the unit is mounted on a motor. These self-contained mounting and coupling features can result in reduced interface cost.



### SPECIFICATIONS

#### Electrical

<b>Code</b>	Incremental
<b>Output Format</b>	2 channels in quadrature, 1/2 cycle index gated with negative B channel
<b>Cycles Per Shaft Turn</b>	1 to 28,800 For resolutions above 3,600 consult factory for interpolation options
<b>Supply Voltage</b>	5 to 28 VDC available
<b>Current Requirements</b>	100 mA typical +output load, 250 mA (max)
<b>Voltage/Output</b>	(see note 5) 28V/V: Line Driver, 5–28 VDC in, Vout = Vin 28V/5: Line Driver, 5–28 VDC in, Vout = 5 VDC 28V/OC: Open Collector, 5–28 VDC in, OCout
<b>Protection Level</b>	Reverse, overvoltage and output short circuit (see note 5)
<b>Frequency Response</b>	100 kHz, up to 800 KHz with interpolation option (see note 7)
<b>Output Terminations</b>	(See Table 1 at the end of the datasheet)
<b>Note</b>	Consult factory for other electrical options



## SPECIFICATIONS (CONTINUED)

### Mechanical

<b>Coupling Bore</b>	1/4" and 3/8" nominal, standard
<b>Starting Torque at 25°C</b>	0.07 in-oz typical shielded; 2.0 in-oz typical SB
<b>Bearings</b>	Class ABEC 5
<b>Coupling Material</b>	Aluminum with protective finish
<b>Bearing Housing</b>	Die cast aluminum with protective finish
<b>Cover</b>	Drawn aluminum, 0.060" wall, protective finish standard. Die cast aluminum with protective finish for EM, SM, ECS and SCS terminations
<b>Bearing Life</b>	1 X 10 <sup>9</sup> revs (6,700 hrs at 2500 RPM) at rated load
<b>Maximum RPM</b>	10,000
<b>Weight</b>	13 oz., typical
<b>Enclosure Rating</b>	NEMA 2 (IP43)

### Environmental

<b>Temperature</b>	Operating, 0° to 70° C; extended temperature testing available (see note 8); Storage, -25° to 90°C unless extended temperature option called out.
<b>Shock</b>	50 g's for 11 msec duration
<b>Vibration</b>	5 to 2000 Hz @ 20 g's
<b>Humidity</b>	98% RH without condensation

**NOTES & TABLES:** All notes and tables referred to in the text can be found at the end of the datasheet.



## COUPLING PERFORMANCE DATA

Coupling Data	Standard Coupling Type 4H	High-Performance Coupling	
		Type 4R	Type 6R
Coupling Bore	.250/.251	.2500/.2505	.3750/.3755
Dimension A1(E25BA only)	.16	.08	.08
Dimension A2 (E25BB & BC)	.10	.02	.02
Axial Motion (Inches Max.)	±.010	±.020	±.030
Parallel Offset (Inches Max.)	.010	.010	.010
Angular Misalignment (Degrees Max.)	2	2	2
Torsional Spring Rate (arc-sec/oz-in)	52	15	21

**Installation Note:** To prevent damage, the coupling must be operated without excessive axial compression or extension. For proper installation, rotate the coupling on the mating shaft prior to tightening the set screws.



# DIMENSIONS

Dimensions in inches

## E25BA

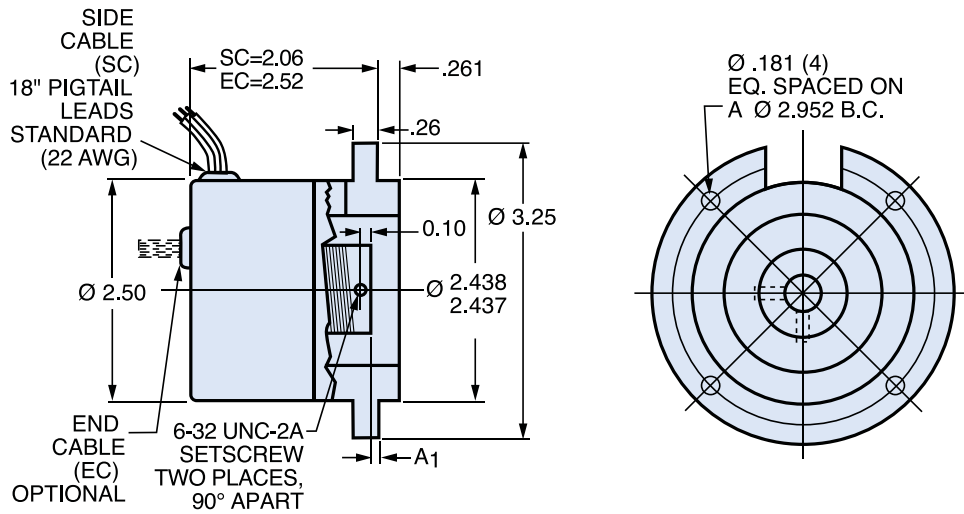

## E25BB (NEMA 34/42 Compatible)

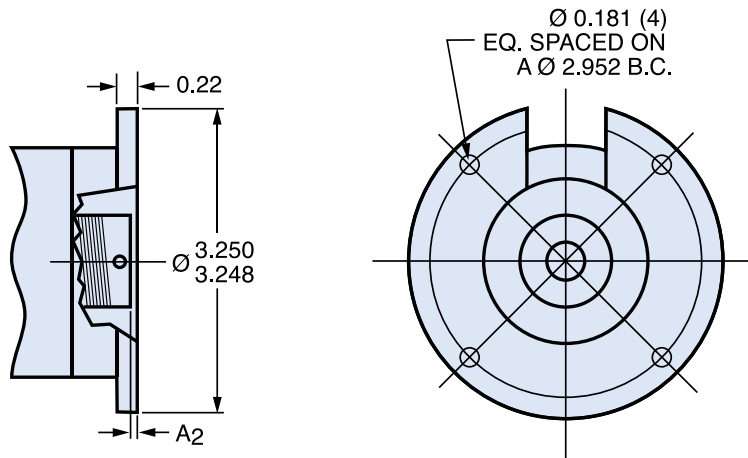

## E25BC

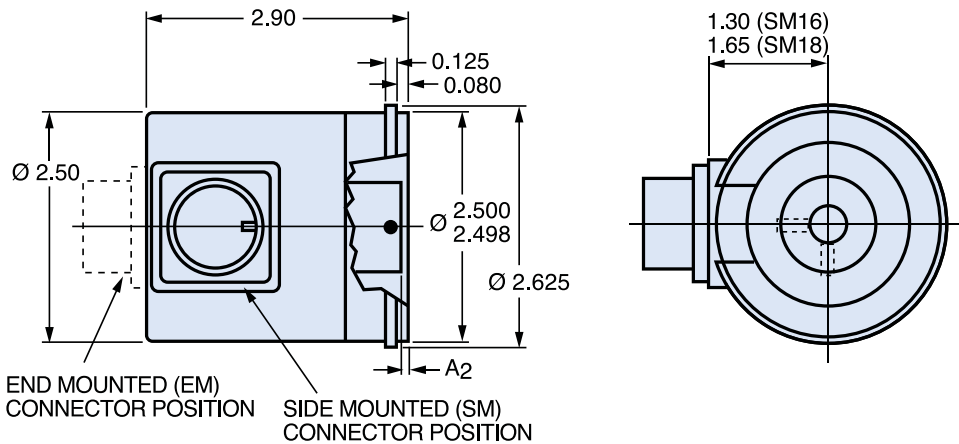



Contact the factory for special versions, ex: special flanges, electronics, connections...

**Family** E25 BB 4H 500 ABZ C 28V/V S M18

**E: Economy**  
**25:** 2.500" Dia.

**Housing Config. Letter**  
**BA, BB, or BC**

**Optional Face Mounts**  
**4H:** 0.250 I.D., Std  
**4R:** 0.250 I.D., High Performance  
**6R:** 0.375 I.D., High Performance

**Shaft Seal Configuration**  
**SB:** Seal Integral with Bearing  
**Blank:** Shielded Bearing  
*See note 2*

**Cycles Per Turn**  
1, 2, 3, 5, 6, 7, 8, 10, 13, 16, 20, 24, 25, 26, 30, 32, 33, 34, 36, 37, 40, 45, 48, 50, 51, 56\*, 60, 64, 66, 72, 75, 80, 86, 88, 90, 100, 102, 120, 122, 125, 127, 128, 132, 144, 148, 150, 158, 160, 175, 176, 180, 187, 192, 200, 202, 204\*, 217, 220, 240, 250, 254, 255, 256, 264\*, 274, 280, 283, 288, 292, 300, 312, 320, 321, 325, 360, 366, 372, 375, 377, 380, 381, 384, 385, 393, 400, 430, 432, 450, 462, 480, 490, 500, 502, 508, 512, 522, 530, 550, 560\*, 576, 598, 600, 604, 625, 628, 635, 638, 640, 660, 672, 676, 680, 687, 690, 700, 720, 725, 735, 740, 744, 748, 750, 762, 768, 780, 785, 800, 812, 825, 850, 864, 878, 888, 900, 912, 914, 938, 942, 955, 960, 1000, 1016, 1024, 1030, 1035, 1036, 1040, 1054, 1056, 1074, 1076, 1080, 1088, 1100, 1101, 1125, 1136, 1200, 1237, 1250, 1257, 1270, 1280, 1300, 1314, 1332, 1333, 1390, 1400, 1414, 1427, 1440, 1484, 1500, 1562, 1570, 1596, 1600, 1650, 1666, 1718, 1745, 1774, 1800, 1840\*, 1850, 1855, 1875, 1894, 1920, 1952, 1968, 1979, 1995, 2000, 2048, 2080, 2094, 2100, 2160, 2164, 2199, 2200, 2250, 2356, 2400, 2485, 2500, 2514, 2519, 2540, 3000, 3125, 3600, 4000, 4096, 5000

*\*AB or ABC output only.*  
*Note: Resolutions up to 72,000 are available*

**No. of Channels**  
**A:** Single Channel  
**AB:** Dual Quad. Ch.  
**ABZ:** Dual with Index  
**AZ:** Single with Index  
*See note 3*

**Complements**  
**C:** Complementary Outputs  
**Blank:** None  
*See note 4*

**Voltage/Output**  
**15V/V:** 5-15 V<sub>in/out</sub>  
**28V/V:** 5-28V<sub>in/out</sub>  
**28V/5:** 5-28V<sub>in</sub>, 5V<sub>out</sub>  
**28V/OC:** 5-28V<sub>in</sub>, OC<sub>out</sub>  
*See note 5*

**Output Termination Location**  
**E:** End  
**S:** Side

**Output Termination**  
**M16:** MS3102R16S-1P, 7-Pin  
**M18:** MS3102R18-1P, 10-Pin  
**C:** Pigtail Cable  
**CS:** Cable with seal  
Cable length specified in inches  
(i.e. C18 = Pigtail 18" long)  
*See table 1*

**Special Features**  
**S:** Special features specified on purchase order (consult factory)  
*See note 6*



## TABLE 1: INCREMENTAL OUTPUT TERMINATIONS

The connector style will determine pinouts. For example, an encoder with ABC channels and an M18 connector uses the table below.

M14 Connector PIN	M16 Connector PIN	Channels Designated in Model No.	
		ABZ	ABC
E	A	A	A
D	B	B	B
C	C	Z	$\bar{A}$
B	D	+V (Supply Voltage)	
F	E	-	$\bar{B}$
A	F	0 V (Circuit Common)	
	G	Case Ground (CG) (except H20)	

M18 Connector	
PIN	Channel
A	A
B	B
C	Z
D	+V
E	-
F	0V
G	CG
H	$\bar{A}$
I	$\bar{B}$
J	$\bar{Z}$

Wire Color (22AWG)	DA 15P Connector	Channels Designated in Model No.		
		ABZ	ABC	ABZC
YEL	13	A	A	A
BLUE	14	B	B	B
ORN	15	Z	-	Z
W-Yel	10	-	$\bar{A}$	$\bar{A}$
W-Blu	11	-	$\bar{B}$	$\bar{B}$
W-Orn	12	-	-	$\bar{Z}$
RED	6	+V (Supply Voltage)		
BLK	1	0 V (Circuit Common)		
GRN	9	Case Ground (CG) (except H20)		
WHITE		Shield Drain (Shielded Cable Only)		



### NOTES

1. Mounting is usually done either using the D-style square flange mount, E- or G-style servo mounts, or one of the standard face mounts, F1 for example. Consult factory for additional face mount options.
2. The shaft seal is recommended in virtually all installations. The most common exceptions are applications requiring a very low starting torque or those requiring operation at both high temperature and high speed.
3. Non-standard index widths and multiple indices are available by special order. Consult factory.
4. Complementary outputs are recommended for use with line driver type (source/sink) outputs. When used with differential receivers, this combination provides a high degree of noise immunity.
5. Output IC's: Output IC's are available as either Line Driver (LD) or NPN Open Collector (OC) types. Open Collectors require pull-up resistors, resulting in higher output source impedance (sink impedance is similar to that of line drivers). In general, use of a Line Driver style output is recommended. Line Drivers source or sink current and their lower impedance mean better noise immunity and faster switching times. **Warning:** Do not connect any line driver outputs directly to circuit common/OV, which may damage the driver. Unused outputs should be isolated and left floating. Our applications specialists would be pleased to discuss your system requirements and the compatibility of your receiving electronics with Line Driver type outputs.

**28V/V:** Multi-voltage Line Driver (7272\*): 100 mA source/sink. Input voltage 5 to 28 VDC +/- 5% standard (Note:  $V_{out} = V_{in}$ ). This driver is TTL compatible when used with 5 volt supply. Supply lines are protected against overvoltage to 60 volts and reverse voltage. Outputs are short circuit protected for one minute. Supply current is 120 mA typical (plus load current). This is the recommended replacement for 3904R and 7406R open collector outputs with internal pullup resistors. It is also a direct replacement for any 4469, 88C30, 8830 or 26LS31 line driver

**28V/5:** Multi-voltage Line Driver (7272\*): 100 mA source/sink. Input voltage 5 to 28 VDC +/- 5% standard, internally regulated with 5V (TTL compatible) logic out. Supply lines are protected against overvoltage to 60 volts and reverse voltage. Outputs are short circuit protected for one minute. Supply current is 90 mA typical (plus load current).

**Note:** Limit encoder load to 2.5W max at ambient. Example at 12 VDC:  $2.5W/(+12VDC \text{ minus } +5VDC) = 357 \text{ mA}$  total allowed current. Consult factory for your specific requirements.

**15V/V:** Multi-voltage Line Driver (4469\*): 100 mA source/sink. Input voltage 5 to 15 VDC +/- 5% standard (Note:  $V_{out} = V_{in}$ ). TTL compatible when used with 5 volt supply. Supply lines are protected against overvoltage to 60 volts and reverse voltage. Outputs are short circuit protected for one minute. Supply current is 90 mA typical (plus load current). This is a direct replacement for the 4469 Line Driver.

**28V/OC:** NPN Open Collector (3904\*, 7273\*). Current sink of 80 mA max. Current sourced by external pull-up resistor. Output can be pulled up to voltage other than supply voltage (30 V max). Input voltage 5 to 28 VDC +/- 5% standard. Supply current is 120 mA typical. This replaces prior IC's with designations of 3904, 7406, 3302, 681 and 689.

**5V/OCR, 15V/OCR, 24V/OCR:** Open Collector (3904R\*, 7406R\*, 7273R\*): Current sink of 70 mA max. Includes internal pull-ups sized at approximately 100 ohms/volt. Max current source is 10 mA. Supply current is 100 mA typical, 120 mA with internal pull-ups. The 5V/OCR, 15V/OCR and 24V/OCR are often replaced by the 28V/V in system upgrades.

**3904, 3904R, 4469, 5V/V, 5V/OC, 5V/OCR, 9V/OC:** Intrinsically safe line driver and open collector outputs. These drivers are specific to intrinsically safe encoders, and are installed per the appropriate control drawings listed in Table 2.1 on page 48 of the specifying guide.

**6.** Special -S at the end of the model number is used to define a variety of non-standard features such as special shaft lengths, voltage options, or special testing. Please consult the factory to discuss your special requirements.

**7.** Higher frequency response may be available. Please consult with the factory.

**8.** Extended temperature ratings are available in the following ranges: -40 to 70°C, -40 to 85°C, -20 to 105°C and -40 to 105°C depending on the particular model. Some models can operate down to -55°C. Extended temperature ranges can affect other performance factors. Consult with factory for more specific information.

**9.** Mating straight plug receptacles may be ordered from the factory:

For M12 use MS3116F12-10S, For M14 use MS3106F14S-6S

For M14/19 use MS3116J14-19S, For M16 use MS3106F16S-1S

For M18 use MS3106F18-1S, For M20 use MS3106F20-29S

\* Products manufactured prior to April 2007 used the line driver IC number instead of voltage output in model number



## AGENCY APPROVALS & CERTIFICATIONS



The E25 Incremental Encoder is available with the following certifications:  
EN 55011 and EN 61000-6-2

Revised 2/26/18

Sensata Technologies, Inc. ("Sensata") data sheets are solely intended to assist designers ("Buyers") who are developing systems that incorporate Sensata products (also referred to herein as "components"). Buyer understands and agrees that Buyer remains responsible for using its independent analysis, evaluation and judgment in designing Buyer's systems and products. Sensata data sheets have been created using standard laboratory conditions and engineering practices. Sensata has not conducted any testing other than that specifically described in the published documentation for a particular data sheet. Sensata may make corrections, enhancements, improvements and other changes to its data sheets or components without notice.

Buyers are authorized to use Sensata data sheets with the Sensata component(s) identified in each particular data sheet. HOWEVER, NO OTHER LICENSE, EXPRESS OR IMPLIED, BY ESTOPPEL OR OTHERWISE TO ANY OTHER SENSATA INTELLECTUAL PROPERTY RIGHT, AND NO LICENSE TO ANY THIRD PARTY TECHNOLOGY OR INTELLECTUAL PROPERTY RIGHT, IS GRANTED HEREIN. SENSATA DATA SHEETS ARE PROVIDED "AS IS". SENSATA MAKES NO WARRANTIES OR REPRESENTATIONS WITH REGARD TO THE DATA SHEETS OR USE OF THE DATA SHEETS, EXPRESS, IMPLIED OR STATUTORY, INCLUDING ACCURACY OR COMPLETENESS. SENSATA DISCLAIMS ANY WARRANTY OF TITLE AND ANY IMPLIED WARRANTIES OF MERCHANTABILITY, FITNESS FOR A PARTICULAR PURPOSE, QUIET ENJOYMENT, QUIET POSSESSION, AND NON-INFRINGEMENT OF ANY THIRD PARTY INTELLECTUAL PROPERTY RIGHTS WITH REGARD TO SENSATA DATA SHEETS OR USE THEREOF.

All products are sold subject to Sensata's terms and conditions of sale supplied at [www.sensata.com](http://www.sensata.com) SENSATA ASSUMES NO LIABILITY FOR APPLICATIONS ASSISTANCE OR THE DESIGN OF BUYERS' PRODUCTS. BUYER ACKNOWLEDGES AND AGREES THAT IT IS SOLELY RESPONSIBLE FOR COMPLIANCE WITH ALL LEGAL, REGULATORY AND SAFETY-RELATED REQUIREMENTS CONCERNING ITS PRODUCTS, AND ANY USE OF SENSATA COMPONENTS IN ITS APPLICATIONS, NOTWITHSTANDING ANY APPLICATIONS-RELATED INFORMATION OR SUPPORT THAT MAY BE PROVIDED BY SENSATA.

Mailing Address: Sensata Technologies, Inc., 529 Pleasant Street, Attleboro, MA 02703, USA.

## CONTACT US

### Americas

+1 (800) 350 2727 – Option 1  
sales.beisensors@sensata.com  
**Europe, Middle East & Africa**  
+33 (3) 88 20 8080  
position-info.eu@sensata.com

### Asia Pacific

sales.isasia@list.sensata.com  
China +86 (21) 2306 1500  
Japan +81 (45) 277 7117  
Korea +82 (31) 601 2004  
India +91 (80) 67920890  
Rest of Asia +886 (2) 27602006  
ext 2808

## X-ON Electronics

Largest Supplier of Electrical and Electronic Components

*Click to view similar products for [Encoders](#) category:*

*Click to view products by [Sensata](#) manufacturer:*

Other Similar products are found below :

[6-1393048-0](#) [6-1393048-5](#) [62AG22-H5-P](#) [700-09-36](#) [1393047-3](#) [ECW1J-C36-SE0/077L](#) [2-1393047-2](#) [25LB22-G-Z](#) [T101-5C3-111-M1](#)  
[385001M0439](#) [385001M0216](#) [V23401H1409B101](#) [V23401T8002B802](#) [V23401U6019B609](#) [62B11-LPP-040C](#) [62HS22-H0-040S](#) [700-16-16](#)  
[700-24-24](#) [V23401D1001B102](#) [3-1393048-1](#) [288T220R161A2](#) [1-1879391-5](#) [GH65C11-N-SO](#) [1393047-1](#) [702-01-24](#) [703-20-00](#) [62V22-02-P](#)  
[62D15-02-140S](#) [61K128-075](#) [EC21C1520402](#) [62AG18-L5-020C](#) [E6F-AG5C 720 2M](#) [62B22-SPP-030C](#) [60016-005](#) [31215-003](#) [01039-2677](#)  
[ACZ11BR2E-20FD1-20CZ-0546](#) [DXM510-2000S002](#) [01002-2133](#) [01002-9375](#) [01002-9572](#) [01026-476](#) [01039-1102](#) [01039-1981](#) [01070-](#)  
[1315](#) [01072-513](#) [01080-056](#) [01084-089](#) [01094-017](#) [01102-031](#)