

## H25 | INCREMENTAL OPTICAL ENCODER



### Introduction

The H25 is the flagship of the BEI Sensors product line. It was designed from the ground up for the industrial marketplace. The H25 offers features such as EMI shielding, 40 lb. ABEC 7 bearings, matched thermal coefficients on critical components, and custom high efficiency optics. The encoder meets NEMA 4 and 13 requirements when ordered with the shaft seal. Typical applications include machine control, process control, the wood processing industry, oil well logging, industrial weighing, agricultural machinery, textile equipment, web process control, robotics, and food processing.

### SPECIFICATIONS

#### Mechanical

<b>Shaft Diameter</b>	3/8" nominal (1/2" as special feature)
<b>Flat On Shaft</b>	3/8" Shaft: 0.80 long X 0.03" deep; 1/2" Shaft: 0.80 long X 0.04" deep (1/2" shaft w/flat must be ordered as special feature)
<b>Shaft Loading</b>	3/8" shaft: Up to 40 pounds axial and 35 pounds radial; 1/2" shaft: Up to 90 pounds axial and 80 pounds radial
<b>Shaft Runout</b>	0.0005 T.I.R. at midpoint regardless of shaft diameter
<b>Starting Torque at 25°C</b>	Without shaft seal 1.0 in-oz (max); With shaft seal 2.5 in-oz (max); 1/2" shaft with shaft seal: 3.5 in-oz (max)
<b>Bearings</b>	Class ABEC 7 standard, ABEC 5 for 1/2" shaft
<b>Shaft Material</b>	416 stainless steel
<b>Bearing Housing</b>	Die cast aluminum with protective finish; stainless steel (special feature)
<b>Cover</b>	Die cast aluminum; stainless steel (special feature)
<b>Bearing Life</b>	2 X 10 <sup>9</sup> revs (1300 hrs at 2500 RPM) at rated load 1 X 10 <sup>10</sup> revs (67,000 hrs at 2500 RPM) at 10% of rated load
<b>Maximum RPM</b>	12,000 RPM nominal, 8000 RPM with 1/2" shaft (see Frequency Response, below) 30,000 RPM available on units with 3/8" shaft—consult with factory
<b>Moment of Inertia</b>	4.1 X 10 <sup>-4</sup> oz-in-sec <sup>2</sup> ; 5.2 X 10 <sup>-4</sup> oz-in-sec <sup>2</sup> with 1/2" shaft
<b>Weight</b>	13 oz typical, 14.5 oz typical with 1/2" shaft



Electrical

<b>Code</b>	Incremental
<b>Output Format</b>	2 channels in quadrature, 1/2 cycle index gated with negative B channel
<b>Cycles per Shaft Turn</b>	1 to 72,000 (see table 2) For resolutions above 3,600 see BEI for interpolation options
<b>Supply Voltage</b>	5 to 28 VDC available
<b>Current Requirements</b>	100 mA typical +output load, 250 mA (max)
<b>Voltage/Output</b>	(see note 5) <b>15V/V:</b> Line Driver, 5–15 VDC in, Vout = Vin <b>28V/V:</b> Line Driver, 5–28 VDC in, Vout = Vin <b>28V/5:</b> Line Driver, 5–28 VDC in, Vout = 5 VDC <b>28V/OC:</b> Open Collector, 5–28 VDC in, OCout
<b>Protection Level</b>	Reverse, overvoltage and output short circuit (see note 5)
<b>Frequency Response</b>	100 kHz, up to 1MHz with interpolation option (see note 7)
<b>Output Terminations</b>	See Table 1
<b>Note</b>	Consult factory for other electrical options

Environmental

<b>Enclosure Rating</b>	NEMA 4 & 13 (IP 66) when ordered with shaft seal (on units with an MS connector) or a cable gland (on units with cable termination).
<b>Temperature</b>	Operating, 0° to 70° C; extended temperature testing up to 105°C available; Storage, -25° to 90° C unless extended temperature option called out.
<b>Shock</b>	50 g's for 11 msec duration
<b>Vibration</b>	5 to 2000 Hz @ 20 g's
<b>Humidity</b>	98% RH without condensation



# DIMENSIONS

Dimensions in mm

## H25D - Square Flange

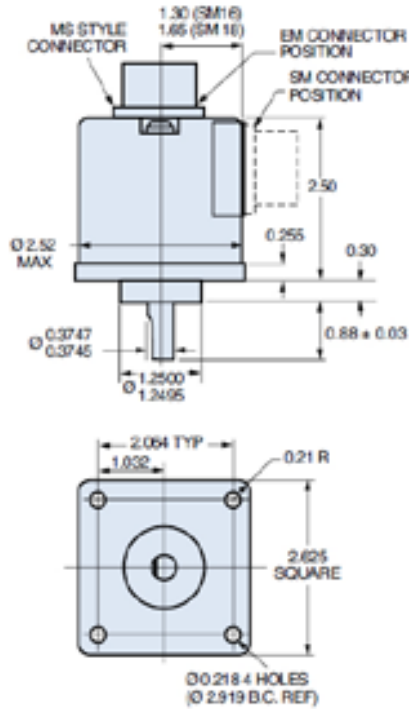

TOLERANCES: .XX = ±0.01, .XXX = ±0.005

## H25E - 2.50 Servo Mount

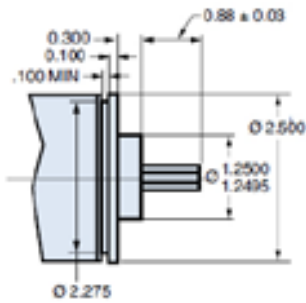

## H25G - 2.62 Dia Servo Mount

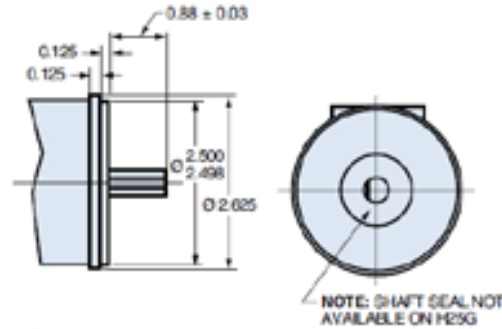

## Optional Face Mounts

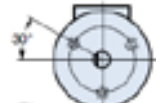

F1  
10-32 UNF-2B  
0.188 Min. Deep  
3 places equally spaced  
on a Ø 1.875 bolt circle.

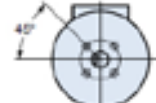

F2 (H25G Only)  
4-40 UNC-2B  
0.250 Min. Deep  
4 places equally spaced  
on a Ø 1.072 bolt circle.  
(0.900 square, Plat.)



F3  
4-40 UNC-2B  
0.250 Min. Deep  
4 places equally spaced  
on a Ø 2.00 bolt circle.

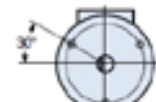

F4  
6-32 UNC-2B  
0.250 Min. Deep  
3 places equally spaced  
on a Ø 2.00 bolt circle.

**Table 1: Incremental Output Terminations**

The connector style will determine pinouts. For example, an encoder with ABC channels and an M18 connector uses the table to the right.

M14 Connector	M16 Connector	Channels Designated in Model Number	
Pin	Pin	ABZ	ABC
E	A	A	A
D	B	B	B
C	C	Z	$\bar{A}$
B	D	+V (Supply Voltage)	
F	E	—	$\bar{B}$
A	F	0V (Circuit Common)	
	G	Case Ground (CG) (except H20)	

M14 Connector	
Pin	Channel
A	A
B	B
C	Z
D	+V
E	—
F	0V
G	CG
H	$\bar{A}$
I	$\bar{B}$
J	$\bar{Z}$

Wire Color (22AWG)	DA 15P Connector	Channels Designated in Model Number		
		ABZ	ABC	ABZC
YEL	13	A	A	A
BLUE	14	B	B	B
ORN	15	Z	—	Z
W-Yel	10	—	$\bar{A}$	$\bar{A}$
W-Blu	11	—	$\bar{B}$	$\bar{B}$
W-Orn	12	—	—	$\bar{Z}$
RED	6	+V (Supply Voltage)		
BLK	1	0V (Circuit Common)		
GRN	9	Case Ground (CG0) (except H20)		
WHITE		Shield Drain (Shielded Cable Only)		

M12 Connector	
Pin	Channel
A	A
B	B
C	Z
D	+V
E	—
F	0V
G	CG
H	$\bar{A}$
J	$\bar{B}$
K	$\bar{Z}$

**Table 2: Disc Resolutions for Incremental Encoder Models H25, H38, H40, L25, E25**

Resolutions highlighted with   are available H25 EXPRESS ENCODERS® that ship in one to three days.

1, 2, 5, 6, 7, 8, 10, 13, 16, 20, 24, 25, 26, 30, 32, 33, 34, 36, 37, 40, 45, 48, 50, 51, 56\*, 60, 64, 66, 72, 75, 80, 86, 88, 90, 100, 102, 120, 122, 125, 127, 128, 132, 144, 148, 150, 158, 160, 175, 176, 180, 187, 192, 200, 202, 204\*, 217, 220, 240, 250, 254, 255, 256, 264\*, 274, 280, 283, 288, 292, 300, 312, 320, 321, 325, 360, 366, 372, 375, 377, 380, 381, 384, 385, 393, 400, 430, 432, 450, 462, 480, 490, 500, 502, 508, 512, 522, 530, 550, 560\*, 576, 598, 600, 604, 625, 635, 638, 640, 660, 672, 676, 680, 687, 690, 700, 720, 725, 735, 740, 744, 748, 750, 762, 768, 780, 785, 800, 812, 825, 850, 864, 878, 888, 900, 912, 914, 938, 942, 955, 960, 1000, 1016, 1024, 1030, 1035, 1036, 1040, 1054, 1056, 1074, 1076, 1080, 1088, 1100, 1101, 1125, 1136, 1200, 1237, 1250, 1257, 1270, 1280, 1300, 1314, 1332, 1333, 1390, 1400, 1414, 1427, 1440, 1484, 1500, 1562, 1570, 1596, 1600, 1650, 1666, 1718, 1745, 1774, 1800, 1840\*, 1850, 1855, 1875, 1894, 1920, 1952, 1968, 1979, 1995, 2000, 2048, 2080, 2094, 2100, 2160, 2164, 2199, 2200, 2250, 2356, 2400, 2485, 2500, 2514, 2519, 2540, 2821, 2827, 2833, 3000, 3125, 3600, 4000, 4096, 5000

\*AB or ABC output only. NOTE: Resolutions up to 72,000 are available.



# ORDERING OPTIONS

Example : H25D-SS-2000-ABZC-28V/V-S M18

**H25** **D** - - **SS** - **2000** - **ABZ** **C** - **28V/V** - **S** **M18** - -

### Express Encoder

**X** = Express Encoder

### Type

**H** = Heavy Duty;  
**25** = 2.500" Diameter

### Housing Configuration

**D** = Square Flange  
**E** = 2.50 Diameter Servo Mount  
**G** = 2.62 Diameter Servo Mount  
*See dimensions*

### Optional Face Mounts

**F1** (E housing only), **F2**, **F3**, or **F4**  
**Blank** = None  
*See note 1*

### Shaft Seal Configuration

**SS** = Shaft Seal (Not available on H25G)  
**Blank** = Shielded Bearing  
*See note 2*

### Cycles Per Turn

(Enter Cycles)  
*See Table 2*

### Number of Channels

**A** = Single Channel  
**AB** = Dual Quad. Channel  
**ABZ** = Dual with Index  
**AZ** = Single with Index  
*See note 3*

### Complements

**C** = Complementary Outputs  
**Blanks** = None  
*See note 4*

### Voltage/Output

**15V/V** = 5-15 V<sub>in</sub>/out  
**28V/V** = 5-28V<sub>in</sub>/out  
**28V/5** = 5-28V<sub>in</sub>/5V<sub>out</sub>  
**28V/OC** = 5-28V<sub>in</sub>/OC<sub>out</sub>  
*See note 5*

### Output Termination Location

**E** = End  
**S** = Side

### Output Termination

**M12** = MS3112E12-10P  
**M16** = MS3102R16S-1P  
**M18** = MS3102R18-1P  
**C** = Pigtail Cable  
**CS** = Cable with seal  
*Cable length specified in inches*  
*(i.e. C18 = Pigtail 18" long)*  
*See table 1 & note 9*

### Hazardous Area Ratings

**Blank** = None  
**EX** = Intrinsically Safe  
**NI** = Non-Incendive  
*Contact factory for voltage options*

### Special Features

**S** = Special  
Features specified on purchase order (consult factory)  
*See note 6*

**EXPRESS ENCODERS:** Items highlighted with   are standard Express Encoders and ship in one to three days.  
*T2 and T5 options are available as standard H25 Express Encoder model options.*

1. Mounting is usually done either using the D-style square flange mount, E- or G-style servo mounts, or one of the standard face mounts, F1 for example. Consult factory for additional face mount options.
2. The shaft seal is recommended in virtually all installations. The most common exceptions are applications requiring a very low starting torque or those requiring operation at both high temperature and high speed.
3. Non-standard index widths and multiple indices are available by special order. Consult factory.
4. Complementary outputs are recommended for use with line driver type (source/sink) outputs. When used with differential receivers, this combination provides a high degree of noise immunity.
5. **Output IC's:** Output IC's are available as either Line Driver (LD) or NPN Open Collector (OC) types. Open Collectors require pull-up resistors, resulting in higher output source impedance (sink impedance is similar to that of line drivers). In general, use of a Line Driver style output is recommended. Line Drivers source or sink current and their lower impedance mean better noise immunity and faster switching times. **Warning:** Do not connect any line driver outputs directly to circuit common/OV, which may damage the driver. Unused outputs should be isolated and left floating. Our applications specialists would be pleased to discuss your system requirements and the compatibility of your receiving electronics with Line Driver type outputs.
- 28V/V:** Multi-voltage Line Driver (7272\*): 100 mA source/sink. Input voltage 5 to 28 VDC +/- 5% standard (Note:  $V_{out} = V_{in}$ ). This driver is TTL compatible when used with 5 volt supply. Supply lines are protected against overvoltage to 60 volts and reverse voltage. Outputs are short circuit protected for one minute. Supply current is 120 mA typical (plus load current). This is the recommended replacement for 3904R and 7406R open collector outputs with internal pullup resistors. It is also a direct replacement for any 4469, 88C30, 8830 or 26LS31 line driver
- 28V/5:** Multi-voltage Line Driver (7272\*): 100 mA source/sink. Input voltage 5 to 28 VDC +/- 5% standard, internally regulated with 5V (TTL compatible) logic out. Supply lines are protected against overvoltage to 60 volts and reverse voltage. Outputs are short circuit protected for one minute. Supply current is 90 mA typical (plus load current).
- 15V/V:** Multi-voltage Line Driver (4469\*): 100 mA source/sink. Input voltage 5 to 15 VDC +/- 5% standard (Note:  $V_{out} = V_{in}$ ). TTL compatible when used with 5 volt supply. Supply lines are protected against overvoltage to 60 volts and reverse voltage. Outputs are short circuit protected for one minute. Supply current is 90 mA typical (plus load current). This is a direct replacement for the 4469 Line Driver.
- 28V/OC:** NPN Open Collector (3904\*, 7273\*). Current sink of 80 mA max. Current sourced by external pull-up resistor. Output can be pulled up to voltage other than supply voltage (30 V max). Input voltage 5 to 28 VDC +/- 5% standard. Supply current is 120 mA typical. This replaces prior IC's with designations of 3904, 7406, 3302, 681 and 689.
- 5V/OCR, 15V/OCR, 24V/OCR:** Open Collector (3904R\*, 7406R\*, 7273R\*): Current sink of 70 mA max. Includes internal pull-ups sized at approximately 100 ohms/volt. 5V/V, 5V/OC, 5V/OCR and 9V/OC can be intrinsically safe line driver and open collector outputs available on certain model variations. They are intrinsically safe only when installed per the control drawing noted on the certification label affixed to the encoder body.
- 3904, 3904R, 4469, 5V/V, 5V/OC, 5V/OCR, 9V/OC:** Intrinsically safe line driver and open collector outputs. These drivers are specific to intrinsically safe encoders, and are installed per the appropriate control drawings listed in Table 2.1 on page 48.
6. Special -S at the end of the model number is used to define a variety of non-standard features such as special shaft lengths, voltage options, or special testing. Please consult the factory to discuss your special requirements.
7. Higher frequency response may be available. Please consult with the factory.
8. Mating straight plug receptacles may be ordered from the factory:  
 For M12 use MS3116F12-10S, For M14 use MS3106F14S-6S  
 For M14/19 use MS3116J14-19S, For M16 use MS3106F16S-1S  
 For M18 use MS3106F18-1S, For M20 use MS3106F20-29S

\* Products manufactured prior to April 2007 used the line driver IC number instead of voltage output in model number.

Figure 1: Output Waveform

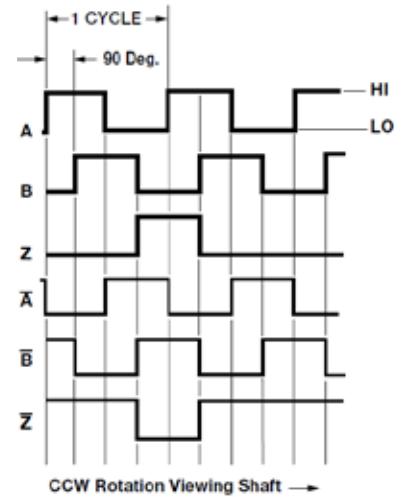



## AGENCY APPROVALS & CERTIFICATIONS



EN 61000-6-4 and EN 61000-6-2



Class I, Group A, B, C & D;  
Class II Group E, F & G



Class I, Zone 0, Group IIC



UL 12.0035X  
UL 13.0071X



CENELEC  
II 1 G Ex ia IIB/IIC T4  
II 3 G Ex nA IIB T4 Gc

Special Models of the H25 Incremental Encoder are available with one or more of the following certifications. Consult factory for details.

Sensata Technologies, Inc. ("Sensata") data sheets are solely intended to assist designers ("Buyers") who are developing systems that incorporate Sensata products (also referred to herein as "components"). Buyer understands and agrees that Buyer remains responsible for using its independent analysis, evaluation and judgment in designing Buyer's systems and products. Sensata data sheets have been created using standard laboratory conditions and engineering practices. Sensata has not conducted any testing other than that specifically described in the published documentation for a particular data sheet. Sensata may make corrections, enhancements, improvements and other changes to its data sheets or components without notice.

Buyers are authorized to use Sensata data sheets with the Sensata component(s) identified in each particular data sheet. HOWEVER, NO OTHER LICENSE, EXPRESS OR IMPLIED, BY ESTOPPEL OR OTHERWISE TO ANY OTHER SENSATA INTELLECTUAL PROPERTY RIGHT, AND NO LICENSE TO ANY THIRD PARTY TECHNOLOGY OR INTELLECTUAL PROPERTY RIGHT, IS GRANTED HEREIN. SENSATA DATA SHEETS ARE PROVIDED "AS IS". SENSATA MAKES NO WARRANTIES OR REPRESENTATIONS WITH REGARD TO THE DATA SHEETS OR USE OF THE DATA SHEETS, EXPRESS, IMPLIED OR STATUTORY, INCLUDING ACCURACY OR COMPLETENESS. SENSATA DISCLAIMS ANY WARRANTY OF TITLE AND ANY IMPLIED WARRANTIES OF MERCHANTABILITY, FITNESS FOR A PARTICULAR PURPOSE, QUIET ENJOYMENT, QUIET POSSESSION, AND NON-INFRINGEMENT OF ANY THIRD PARTY INTELLECTUAL PROPERTY RIGHTS WITH REGARD TO SENSATA DATA SHEETS OR USE THEREOF.

All products are sold subject to Sensata's terms and conditions of sale supplied at [www.sensata.com](http://www.sensata.com) SENSATA ASSUMES NO LIABILITY FOR APPLICATIONS ASSISTANCE OR THE DESIGN OF BUYERS' PRODUCTS. BUYER ACKNOWLEDGES AND AGREES THAT IT IS SOLELY RESPONSIBLE FOR COMPLIANCE WITH ALL LEGAL, REGULATORY AND SAFETY-RELATED REQUIREMENTS CONCERNING ITS PRODUCTS, AND ANY USE OF SENSATA COMPONENTS IN ITS APPLICATIONS, NOTWITHSTANDING ANY APPLICATIONS-RELATED INFORMATION OR SUPPORT THAT MAY BE PROVIDED BY SENSATA.

Mailing Address: Sensata Technologies, Inc., 529 Pleasant Street, Attleboro, MA 02703, USA.

## CONTACT US

### Americas

+1 (800) 350 2727 – Option 1  
[sales.beisensors@sensata.com](mailto:sales.beisensors@sensata.com)  
**Europe, Middle East & Africa**  
+33 (3) 88 20 8080  
[position-info.eu@sensata.com](mailto:position-info.eu@sensata.com)

### Asia Pacific

[sales.isasia@list.sensata.com](mailto:sales.isasia@list.sensata.com)  
China +86 (21) 2306 1500  
Japan +81 (45) 277 7117  
Korea +82 (31) 601 2004  
India +91 (80) 67920890  
Rest of Asia +886 (2) 27602006  
ext 2808

## X-ON Electronics

Largest Supplier of Electrical and Electronic Components

*Click to view similar products for [Encoders](#) category:*

*Click to view products by [SENSATA](#) manufacturer:*

Other Similar products are found below :

[6-1393048-0](#) [6-1393048-5](#) [62AG22-H5-P](#) [63R100](#) [700-09-36](#) [2-1393047-2](#) [25LB22-G-Z](#) [T101-5C3-111-M1](#) [385001M0439](#) [385001M0216](#)  
[V23401H1409B101](#) [V23401T8002B802](#) [1-1414305-0](#) [E69-1](#) [62B11-LP-100S](#) [62S22-H9-120S](#) [62V15-02-080S](#) [63R64-050](#) [700-16-16](#)  
[V23401D3002B301](#) [3-1393048-1](#) [1-1879391-5](#) [GH65C11-N-SO](#) [62S15-M0-P](#) [1393047-1](#) [E69-FCA04](#) [62F01-02-060S](#) [62C1122-01-P](#)  
[62S22-H9-030CH](#) [702-01-24](#) [703-20-00](#) [703-05-00](#) [62D15-02-140S](#) [63R25-120](#) [63K128](#) [62B11-LP-040C](#) [61K128-075](#) [62C2211-02-P](#)  
[63KS50-040](#) [62F11-01-020S](#) [01036-717](#) [62AG18-L5-020C](#) [31301-004](#) [61KS50-120](#) [01072-229](#) [01072-499](#) [62S22-N2-040C](#) [62S22-L4-020CH](#) [62S11-M9-040SH](#) [31215-003](#)