

CD120 SERIES

INCREMENTAL DRAW WIRE

Introduction

Draw wire sensor assemblies combine a rotary sensor such as an encoder with a spring-loaded retractable cable on a drum. This provides a means to translate the precision of a rotary encoder into a linear measurement.

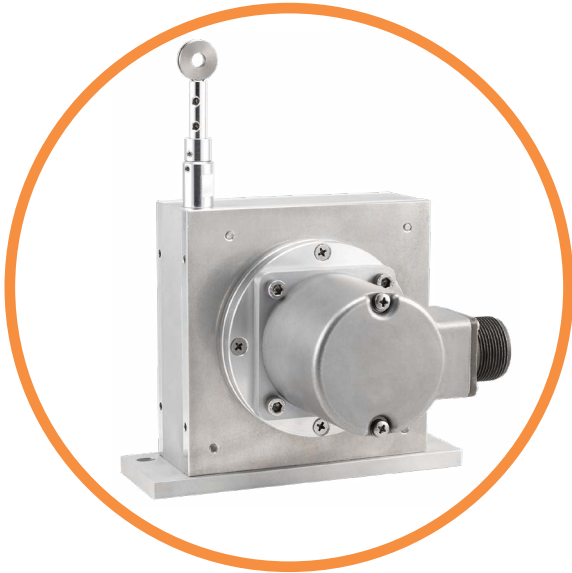

Features

- A full 120 inches (10 feet) of measurement capability.
- Wire drum is scaled so that one revolution = 1 foot of measurement.
- Mounting bracket and encoder position can be rotated in 90° increments to accommodate a variety of installation requirements.

Applications

- Concrete, wood, steel sawing
- Mast height measurement for fork truck AGV's
- Extension measurement for small cranes
- Flood Control gates
- Hydraulic Cylinder Position

SPECIFICATIONS

Mechanical

Output Signal type	Optical Incremental Encoder in Quadrature with Index
Linearity	+/- 0.05% of full scale
Resolution	Range of Pulses per inch (Ref ordering block)
Cable Type	0.024" (0.60 mm) diameter stainless steel
Cable Tension	2.9 - 4.0 pounds (13 - 18 N)
Enclosure material	Aluminum
Weight	4.4 pounds, (2 Kg)

Electrical

Input Current	100mA (no load), up to 160 mA full load
Input Voltage	5-28 Vdc; Vout=Vin
Connector	M16, 7 pin Connector M18, 10 pin Connector SCS, cable Gland Seal
Mating Connector/Cable	31186-18XX, XX = cable length in feet
Drum Circumference	12 inches (304.8 mm)

Environmental

Enclosure Protection Rating	IP66 with M16 or M18 connector IP65 with cable Gland Seal
Operating Temperature	-20°C to + 85°C
Storage Temperature	-20°C to + 85°C

Other Specifications

Maximum Velocity of cable	10 m/s
Maximum Acceleration of Cable	7 m/s ²



DIMENSIONS

Tolerance, unless otherwise noted:
All dimensions are in inches [mm]

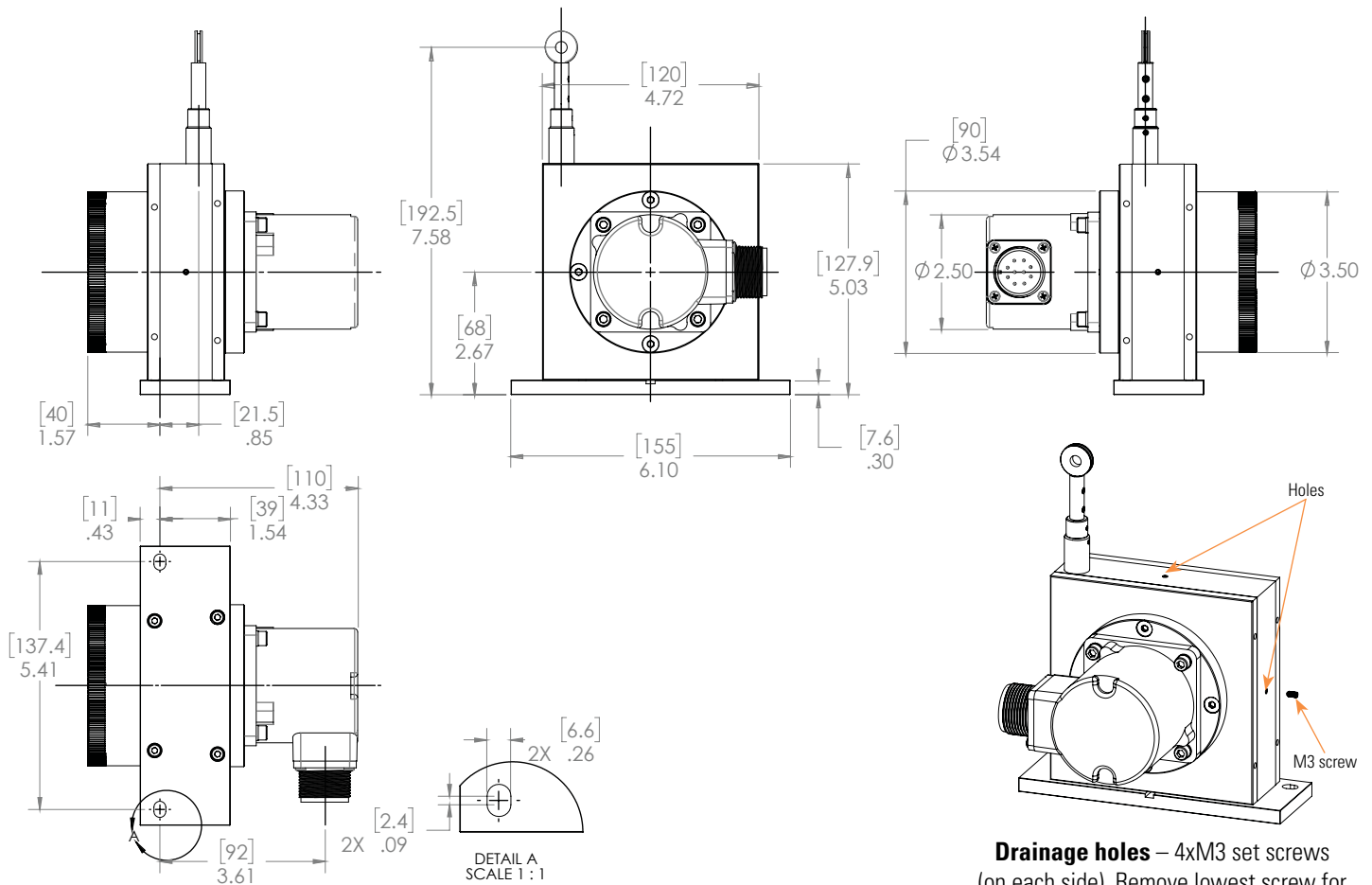

Drainage holes – 4xM3 set screws (on each side). Remove lowest screw for drainage of trapped moisture



CD120 DRAW-WIRE, AVAILABLE FEATURES

All dimensions are in mm

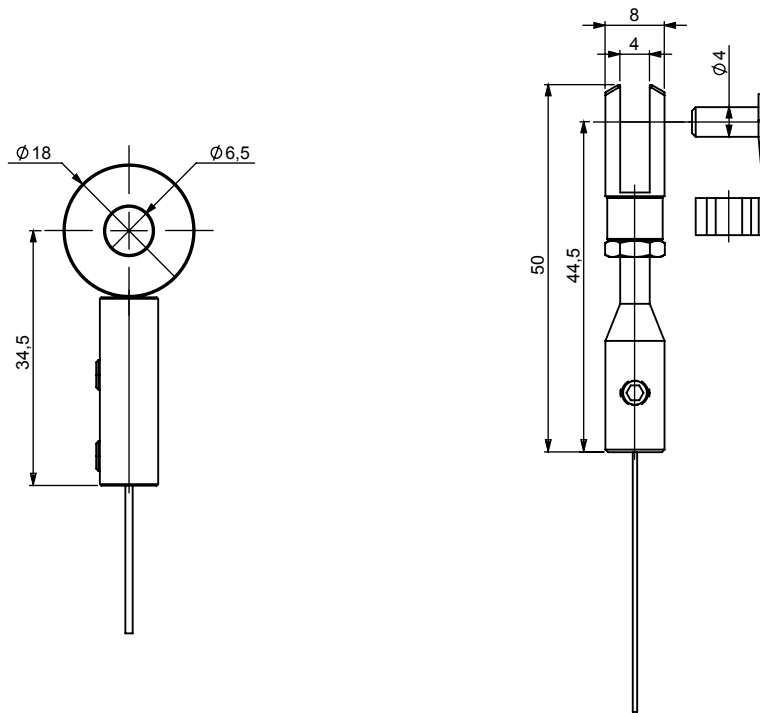

Standard termination with a captive washer which accepts a 6 mm (1/4") screw

CP termination: Threaded cable termination is attached to a clevis. The 4 mm diameter clevis pin is provided.

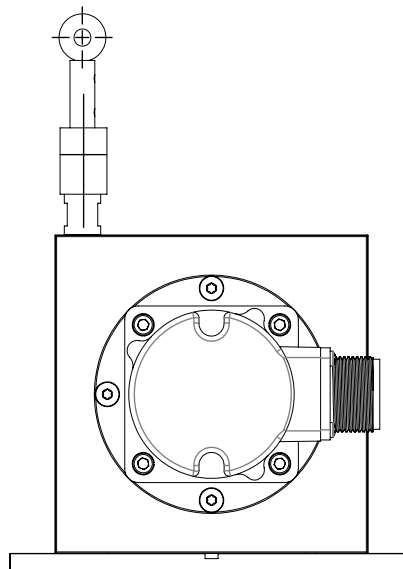

B2: A cleaning brush is factory installed to wipe away dust and moisture as the cable retracts



ORDERING OPTIONS

Example : CD120-500-ABZC-28V/V-M18-B2

CD120 - 500 - ABZC - 28V/V - M18 - B2

Family
 Draw-Wire Assembly
 120 inches maximum travel
 Aluminum Housing

Resolution
Note: programmable resolution, OMNI , must use an M18 termination
 10 counts per inch to 500 counts per inch (See Table, Below)

Output Type
ABZC = Two Channels in Quadrature + Index and complements = Std
ABZ = Two Channels in Quadrature + Index
ABC = Two Channels in Quadrature plus complements
 Check with factory for other output types.

Electrical Options
28V/V = 5 – 28 V in. Vout = Vin
28V/5 = 5 – 28 V in. Vout = 5V regulated
28V/OC = 5 – 28 V in. Vout = Open Collector

Termination
M18 = M18, 10 Pin Connector (used with ABZC)
M18 – 10 = M18 Connector with Mating Cable/Connector Assembly, -10 = 10 foot length. Available lengths are 10, 20, 30, and 50 feet.
M16 = M16, 7 Pin Connector (used with ABC or ABZ)
M16 – 10 = M16 Connector with Mating Cable/Connector Assembly, as above.
SCS-XX = Cable Gland Seal with XX feet of cable. Available lengths (XX) = 10, 20, 30 and 50 feet.

Available Features
BLANK = Standard Termination
B2 = Built-in Cleaning Brush for cable
CP = Clevis Termination



RESOLUTIONS TABLE

Resolution	Distance/ Count
10	0.100 "
25	0.040 "
50	0.020 "
100	0.010"
250	0.004"
500	0.002"
OMNI*	Programmable

*Available with M18 termination only

PINOUT AND CONNECTION TABLES

The connector style will determine pinouts. For example, an encoder with ABC channels and an M18 connector uses the table to the right.

M16 Connector	Channels Designated in Model Number	
Pin	ABZ	ABC
A	A	A
B	B	B
C	Z	\bar{A}
D	+V (Supply Voltage)	
E	—	\bar{B}
F	0V (Circuit Common)	
G	Case Ground (CG)	

M18 Connector	
Pin	Channel
A	A
B	B
C	Z
D	+V
E	—
F	0V
G	CG
H	\bar{A}
I	\bar{B}
J	\bar{Z}

Wire Color (22AWG)	Channels Designated in Model Number		
	ABZ	ABC	ABZC
YEL	A	A	A
BLUE	B	B	B
ORN	Z	—	Z
W-Yel	—	\bar{A}	\bar{A}
W-Blu	—	\bar{B}	\bar{B}
W-Orn	—	—	\bar{Z}
RED	+V (Supply Voltage)		
BLK	0V (Circuit Common)		
GRN	Case Ground (CG0)		
WHITE	Shield Drain (Shielded Cable Only)		

WAVEFORM DIAGRAM

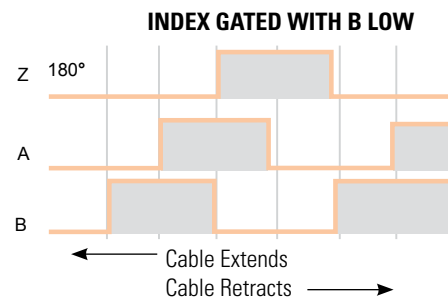

AGENCY APPROVALS & CERTIFICATIONS



EN 61000-6-4 and EN 61000-6-2

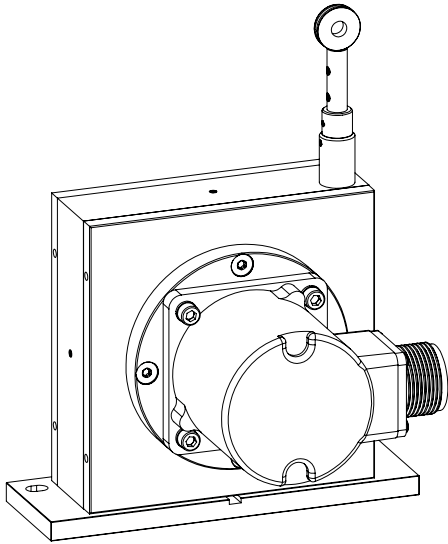

CD120 Mounting Instructions

1. Mount the CD120 mounting plate securely to a stable flat surface using M6 or 1/4" bolts and washers.
2. Attach the draw wire to your moving equipment using the eyelet provided with an M4, #8 screw or a 3/16" pin. If you have purchased a special termination, then use the mounting instructions for that wire termination.



WARNING:

- Damage may occur if draw wire is released and allowed to freely retract without tension.
- Make certain the draw wire path is clear of objects or sharp edges to prevent cable damage.
- Draw wire should exit as straight as possible. A pulley may be used to redirect it

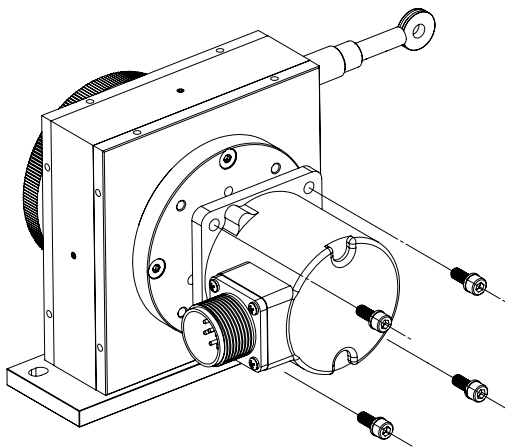

How to Change Encoder Positioning

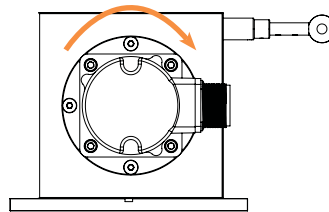

1. Remove the four #10-32 hex socket cap screws and washers from the encoder flange. (5/32 in. hex driver).
2. Rotate the encoder flange in 90° increments. You may need to pull it out a little to get it loose enough to turn.
3. If the encoder is completely removed, you can rotate the encoder shaft a little to align the driving gear with the draw wire hub. It should insert with little or no resistance. Do Not Force the gear into place.
4. Replace the screws and lock washers and tighten to 13 in-lb [1.4 N-m].

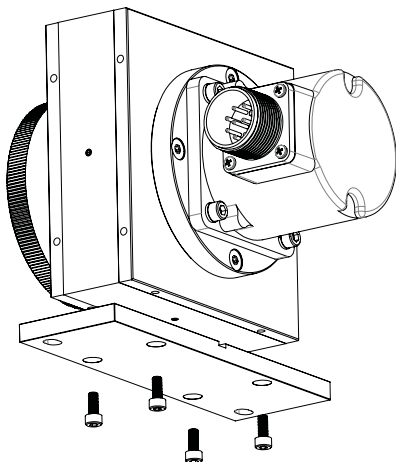

How to Change the Mounting Plate Position

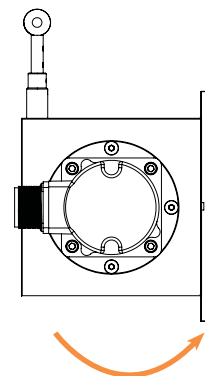

1. Remove the four M4 hex socket cap screws from the mounting plate (3 mm hex driver)
2. Align the mounting plate on the side you wish to attach it.
3. Replace the screws and tighten to 13 in-lb [1.4 N-m].

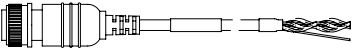
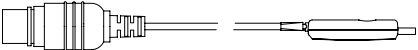

ACCESSORIES

Description	Part Number
<p>M16 Cable Connector Assembly When ordered separately. Cable Assembly may be ordered directly as part of the model number</p> 	<p>MS31186-1610 = 10' MS31186-1620 = 20' MS31186-1630 = 30' MS31186-1650 = 50'</p>
<p>M18 Cable Connector Assembly When ordered separately. Cable Assembly may be ordered directly as part of the model number</p> 	<p>MS31186-1810 = 10' MS31186-1820 = 20' MS31186-1830 = 30' MS31186-1850 = 50'</p>
<p>Omnocoder® Programming Cable Ordered Separately</p> 	<p>60031-101</p>

Sensata Technologies, Inc. ("Sensata") data sheets are solely intended to assist designers ("Buyers") who are developing systems that incorporate Sensata products (also referred to herein as "components"). Buyer understands and agrees that Buyer remains responsible for using its independent analysis, evaluation and judgment in designing Buyer's systems and products. Sensata data sheets have been created using standard laboratory conditions and engineering practices. Sensata has not conducted any testing other than that specifically described in the published documentation for a particular data sheet. Sensata may make corrections, enhancements, improvements and other changes to its data sheets or components without notice.

Buyers are authorized to use Sensata data sheets with the Sensata component(s) identified in each particular data sheet. HOWEVER, NO OTHER LICENSE, EXPRESS OR IMPLIED, BY ESTOPPEL OR OTHERWISE TO ANY OTHER SENSATA INTELLECTUAL PROPERTY RIGHT, AND NO LICENSE TO ANY THIRD PARTY TECHNOLOGY OR INTELLECTUAL PROPERTY RIGHT, IS GRANTED HEREIN. SENSATA DATA SHEETS ARE PROVIDED "AS IS". SENSATA MAKES NO WARRANTIES OR REPRESENTATIONS WITH REGARD TO THE DATA SHEETS OR USE OF THE DATA SHEETS, EXPRESS, IMPLIED OR STATUTORY, INCLUDING ACCURACY OR COMPLETENESS. SENSATA DISCLAIMS ANY WARRANTY OF TITLE AND ANY IMPLIED WARRANTIES OF MERCHANTABILITY, FITNESS FOR A PARTICULAR PURPOSE, QUIET ENJOYMENT, QUIET POSSESSION, AND NON-INFRINGEMENT OF ANY THIRD PARTY INTELLECTUAL PROPERTY RIGHTS WITH REGARD TO SENSATA DATA SHEETS OR USE THEREOF.

All products are sold subject to Sensata's terms and conditions of sale supplied at www.sensata.com SENSATA ASSUMES NO LIABILITY FOR APPLICATIONS ASSISTANCE OR THE DESIGN OF BUYERS' PRODUCTS. BUYER ACKNOWLEDGES AND AGREES THAT IT IS SOLELY RESPONSIBLE FOR COMPLIANCE WITH ALL LEGAL, REGULATORY AND SAFETY-RELATED REQUIREMENTS CONCERNING ITS PRODUCTS, AND ANY USE OF SENSATA COMPONENTS IN ITS APPLICATIONS, NOTWITHSTANDING ANY APPLICATIONS-RELATED INFORMATION OR SUPPORT THAT MAY BE PROVIDED BY SENSATA.

Mailing Address: Sensata Technologies, Inc., 529 Pleasant Street, Attleboro, MA 02703, USA.

CONTACT US

Americas

+1 (800) 350 2727 – Option 1
sales.beisensors@sensata.com

Europe, Middle East & Africa

+33 (3) 88 20 8080
position-info.eu@sensata.com

Asia Pacific

sales.isasia@list.sensata.com
China +86 (21) 2306 1500
Japan +81 (45) 277 7117
Korea +82 (31) 601 2004
India +91 (80) 67920890
Rest of Asia +886 (2) 27602006
ext 2808

X-ON Electronics

Largest Supplier of Electrical and Electronic Components

Click to view similar products for [Encoders](#) category:

Click to view products by [Sensata](#) manufacturer:

Other Similar products are found below :

[6-1393048-0](#) [6-1393048-5](#) [62AG22-H5-P](#) [62B22-LP-030C](#) [63K25](#) [63K32](#) [63KS100](#) [63KS64](#) [63R100](#) [63R50-020](#) [63RS256-060](#) [700-09-36](#)
[RE12D300-201-1](#) [1393047-3](#) [2-1393047-2](#) [T101-5C2-111-M1](#) [T101-5C3-111-M1](#) [T101-5C4-111-M1](#) [385001M0439](#) [385001M0216](#)
[V23401H1409B101](#) [V23401T8002B802](#) [V23401U6019B609](#) [E69-1](#) [E69DF10](#) [E69-FCA](#) [62B11-LP-100S](#) [62B11-LPP-040C](#) [62N11-P](#)
[62S22-H9-120S](#) [62S30-L0-200C](#) [62V15-02-080S](#) [63K64](#) [63KS100-040](#) [63R64-050](#) [63RS64](#) [700-16-16](#) [V23401D3002B301](#) [3-1393048-1](#)
[63KS128](#) [63KS256](#) [1-1879391-5](#) [GH65C11-N-SO](#) [62S15-M0-P](#) [1393047-1](#) [E69-FCA02](#) [E69-FCA04](#) [E69-DF20](#) [E69-DF2](#) [63R50](#)