

Electronic Modules Divide-By Module

BEI Sensors



The Divide-By Module option provides a method to divide the effective resolution and signal frequency of a quadrature output incremental encoder. The Divide By option is available with the BEI Optical Isolator and Broadcaster. The module receives quadrature counts from an incremental encoder and divides them by a predetermined integer value. The index signal is passed through without modification. When combined with the Optical Isolator a single encoder can be used to feed different control devices, synchronizing their outputs at different ratios. This can lower parts count and reduce overall system costs.

This module accepts single ended or differential inputs and divides the signal by a factory set number from 2 to 256. The resulting output signal is a reduced resolution of the input signal. Ideal for use in machine retrofitting and for applications where a different resolution output is needed from the same encoder source. When ordering, make sure to specify the divide-by amount in the model number (see ordering options below).

Specifications

Power:

The optical isolator can accommodate standard operating voltages from 5 to 28 VDC. It should never be connected directly to AC power mains. The module draws approximately 75 mA and a green LED indicates the unit is powered. The optical isolator module does not provide power to the encoder. Any encoders used in conjunction with this module must be connected to their own power.

Signal:

Specifying an optical isolator module requires knowledge of three system parameters: the DC supply voltage available in the system; the encoder output type (logic levels and driver type); and the input signal specifications of the receiving electronics.

Output Code Format From Encoders

Dual Channel in quadrature plus index and complements. Data lines are designated A, B, Z, A', B', Z' at the module

Output Signal Type From Encoder

Differential line driver (Use Connection Instructions #1)

Single ended line driver (Use Connection Instructions #2)

Single ended open collector with pull-up resistors internal to encoder (Use Connection Instructions #3)

Single ended, open collector (Use Connection Instructions #3)

Output Signal Voltage Level From Encoder

5 VDC (TTL, RS422 compatible, line driver)

12-15 VDC

24VDC

Frequency Response of Optical Isolator

1 MHz, maximum

Power Requirements For Optical Isolator

5-28 VDC $\pm 5\%$, 75mA plus load current

Optical Isolator Output Options

28V/V Line Driver, 100mA source/sink, $V_{out} = V_{in}$

28V/5 Line Driver, 100mA source/sink, $V_{out} = 5V$ (Derate output current to 50mA with supply voltage > 12VDC)

28V/OC NPN Open Collector, 80mA sink

Protection Level

Supply lines protected against over voltage to 60 volts and reverse voltage

Tristate Outputs

Available as -S Special Feature

Mechanical

Package dimensions are 114.4 mm high by 99 mm wide by 22.5 mm thick. The package mounts to a DIN rail type EN 50 022 (35mm X 7.5mm). A length of DIN rail is supplied with each module. The module simply snaps directly to the DIN rail and is ready to use.

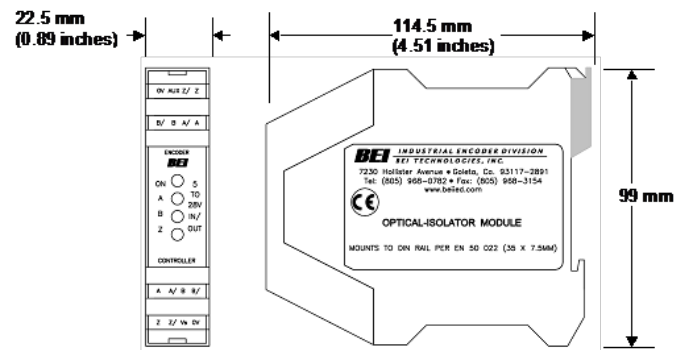

OUTPUT SIGNALS

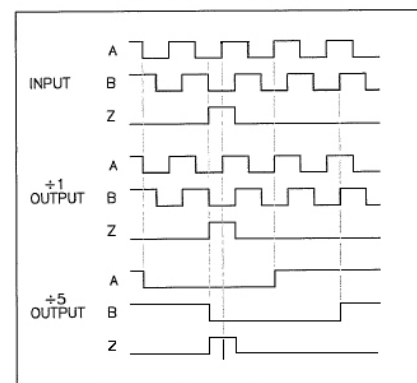

Divide By Module Ordering information FOR ASSISTANCE CALL 800-350-2727

SAMPLE: EM - DR1 - DB2 - 5 - TB

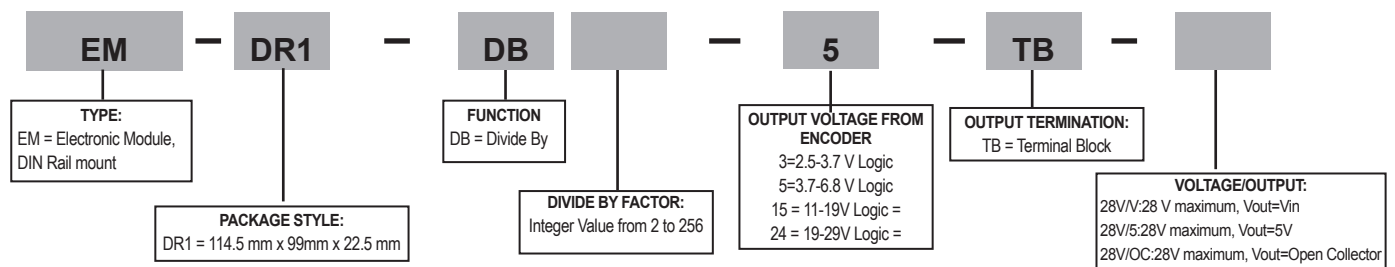

Connection Instructions #1

Differential Line Driver

Encoder signals from 5 VDC to 24 VDC (must specify the voltage when ordering)

This is the preferred type of encoder output as it has the best noise immunity. Connect each encoder signal to its like optical isolator input (A to A, A/ to A/, etc).

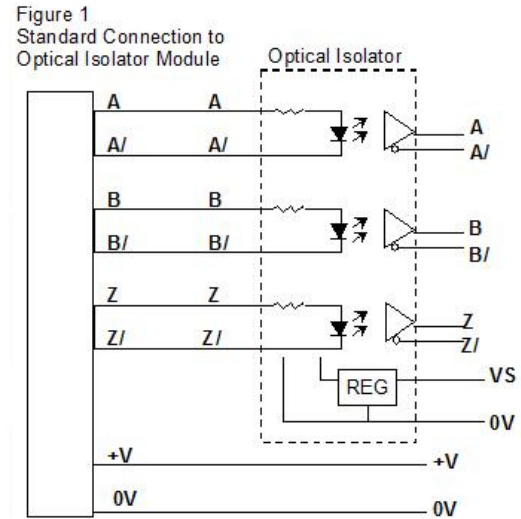
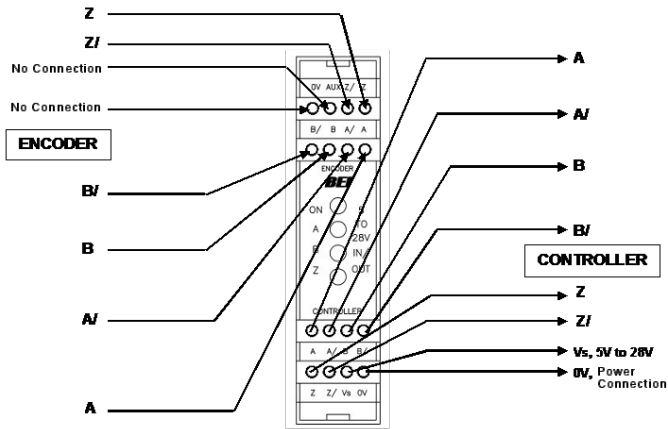

Encoder Differential Line Driver Output

Connection Instructions #2

Single Ended Line Driver

Encoder signals from 5 VDC to 24 VDC (must specify the voltage when ordering)

This is the preferred type of encoder output as it has the best noise immunity. Connect each encoder signal to its like optical isolator input (A to A, A/ to A/, etc).

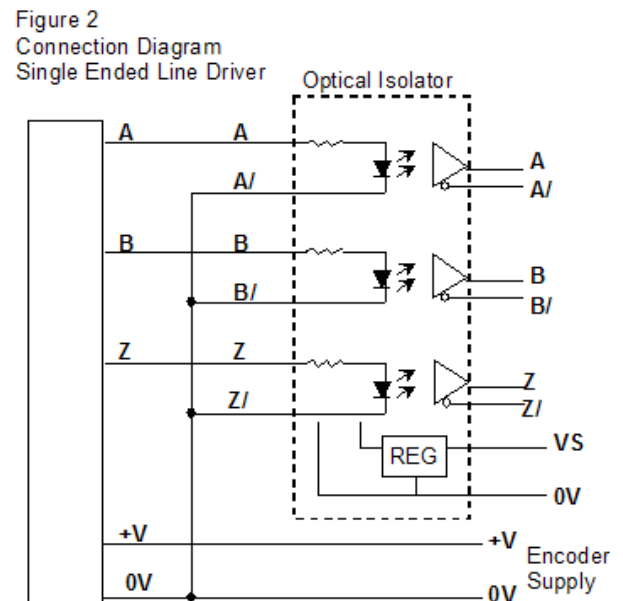
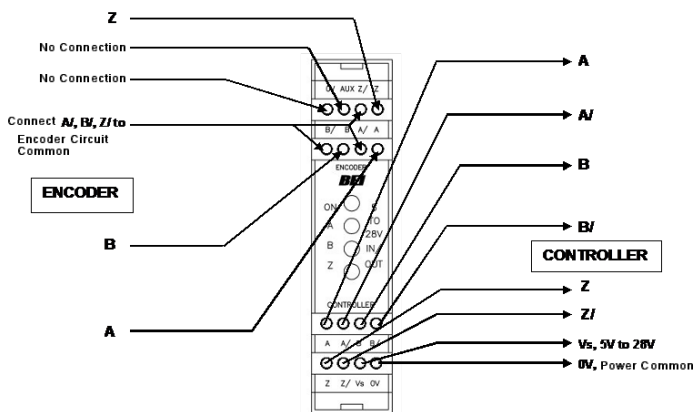

Connection Instructions #3

Open Collector with or without Internal Pull-up Resistors

Encoder NPN (sinking) outputs. Connect encoder output A to optical isolator module input A/, B to B/ and Z to Z/. Connect the A, B, and Z inputs of the optical isolator to the auxiliary output terminal on the optical isolator module for 5V module and to higher voltage when specified by module model and part number. This connection results in a logic inversion within the optical isolator module. To compensate for the logic reversal, swap A for A/, B for B/, and Z for Z/ at the optical isolator outputs.

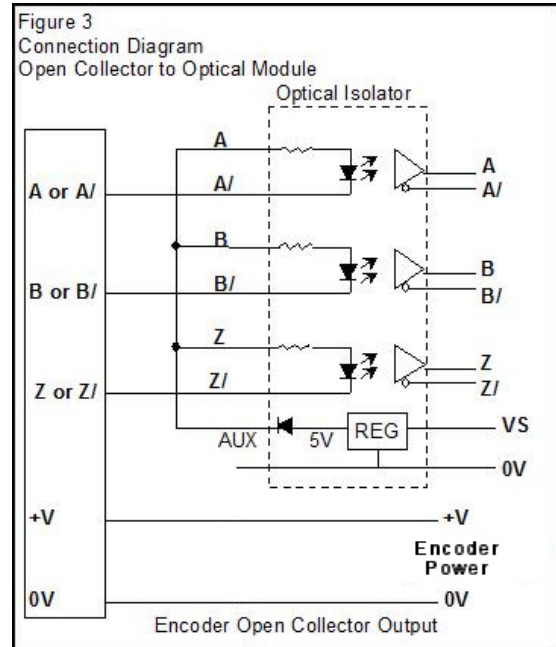
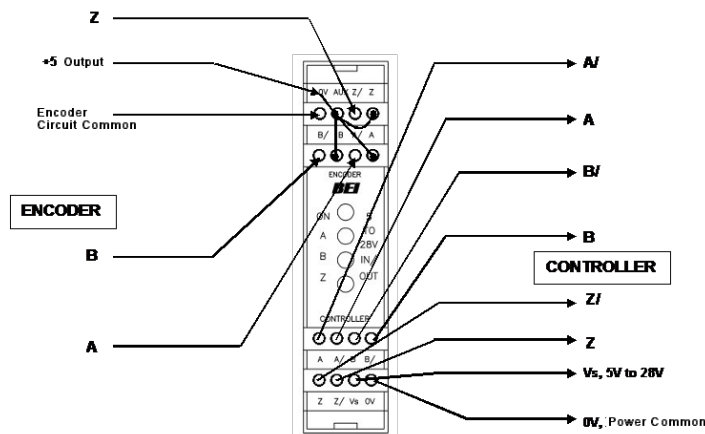

X-ON Electronics

Largest Supplier of Electrical and Electronic Components

Click to view similar products for [Encoders](#) category:

Click to view products by [Sensata](#) manufacturer:

Other Similar products are found below :

[6-1393048-0](#) [6-1393048-5](#) [62AG22-H5-P](#) [700-09-36](#) [1393047-3](#) [ECW1J-C36-SE0/077L](#) [2-1393047-2](#) [25LB22-G-Z](#) [T101-5C3-111-M1](#)
[385001M0439](#) [385001M0216](#) [V23401H1409B101](#) [V23401T8002B802](#) [V23401U6019B609](#) [62B11-LPP-040C](#) [62HS22-H0-040S](#) [700-16-16](#)
[700-24-24](#) [V23401D1001B102](#) [3-1393048-1](#) [288T220R161A2](#) [1-1879391-5](#) [GH65C11-N-SO](#) [1393047-1](#) [702-01-24](#) [703-20-00](#) [62V22-02-P](#)
[62D15-02-140S](#) [61K128-075](#) [EC21C1520402](#) [62AG18-L5-020C](#) [E6F-AG5C 720 2M](#) [62B22-SPP-030C](#) [60016-005](#) [31215-003](#) [01039-2677](#)
[ACZ11BR2E-20FD1-20CZ-0546](#) [DXM510-2000S002](#) [01002-2133](#) [01002-9375](#) [01002-9572](#) [01026-476](#) [01039-1102](#) [01039-1981](#) [01070-](#)
[1315](#) [01072-513](#) [01080-056](#) [01084-089](#) [01094-017](#) [01102-031](#)