

# 8MPP2 SERIES

## MEMS I<sup>2</sup>C DIGITAL LOW PRESSURE SENSOR

### Introduction

The 8MPP2 low pressure sensor utilizes Sensata’s field proven automotive Micro-Electro-Mechanical-Systems (MEMS) technology that outputs fully conditioned pressure values via the digital I<sup>2</sup>C bus. The 8MPP2 features best-in-class performance including high accuracy, low power consumption, and long-term stability in a convenient package for mounting and electrical connection. Compatible with natural gas, air and other gaseous media, the 8MPP2 is an atmospheric pressure reference sensor that accurately measures pressure in the 0-1 psig to 0-5 psig range. Typical applications are in the natural gas network including valves, pipelines, meters, etc.



### Features

- Field proven MEMS sensor technology
- Digital output I<sup>2</sup>C
- Low power consumption (8  $\mu$ A @1Hz )
- Compatible with natural gas
- Small and robust plastic package
- REACH/RoHS/CE compliant

### Applications

- Valves
- Natural gas pipelines
- Gas meters

## SPECIFICATIONS

### Electrical

<b>Supply Voltage</b>	2.7/3.3/5 VDC $\pm$ 10%
<b>Output</b>	Digital I <sup>2</sup> C, 12 bit scaled up to 14 bit
<b>Average Supply Current</b>	8 $\mu$ A average @1Hz Sample Rate
<b>Active Supply Current</b>	2.5mA max
<b>Output Response Time</b>	3.2ms (max), power up to output valid
<b>Overvoltage Protection</b>	6 VDC
<b>Reverse Voltage</b>	-0.3 VDC
<b>Short Circuit Protection</b>	Yes
<b>EMC</b>	EN61000-4 Level 2
<b>ESD</b>	4kV
<b>Radiated Immunity</b>	IEC 61000-4-20; 50V/m level
<b>Electrical Connection</b>	4 position FFC connector, gold terminals

<b>Pressure Ranges</b>	0-1 to 0-5 psig (0 - 69 to 0 – 345 mbar)
<b>Typical Operating Range</b>	0.15-1.0 psig (10 - 69 mbar)

## Physical

<b>Proof Pressure</b>	10 psig (690 mbar)
<b>Burst Pressure</b>	70 psig (4.8 bar)
<b>Random Vibration</b>	0.5G, 5-150Hz
<b>Mechanical Shock</b>	100G
<b>Drop (any Axis)</b>	1m
<b>Humidity</b>	71C, 95%RH
<b>Media Compatibility</b>	Dry Air, Natural Gas, Toluene, Benzene, Iso-octane, Xylene, Stoddard Solution
<b>Sealing O-Ring</b>	O-ring is supplied by customer with correct material for material compatibility. O-ring should be sized in accordance with ISO 3601-109

## Performance

<b>Accuracy @ 25°C (BFSL)<sup>(1)</sup></b>	+/-1.0%FS <sup>(3)</sup> , 25°C
<b>Total Error Band Accuracy<sup>(2)</sup></b>	+/-2.0%FS <sup>(3)</sup> , -40° to 85°C
<b>Aging drift</b>	<0.5 %FS <sup>(3)</sup>
<b>Pressure Reference</b>	Vented/True Gauge
<b>Operating Temperature</b>	-40° to +85°C
<b>Storage Temperature</b>	-40° to +125°C

<sup>(1)</sup> Best fit straight line accuracy includes errors from non-linearity, non-repeatability, and hysteresis

<sup>(2)</sup> Total error band accuracy includes errors from non-linearity, non-repeatability, hysteresis, temperature drift, zero offset, and full span offset

<sup>(3)</sup> Full Scale Pressure = Pmax - Pmin



## DIMENSIONS

Dimensions are in millimeters (mm)

FS (Pressure) = Pmax – Pmin

\*Other Media available upon consultation with Sensata

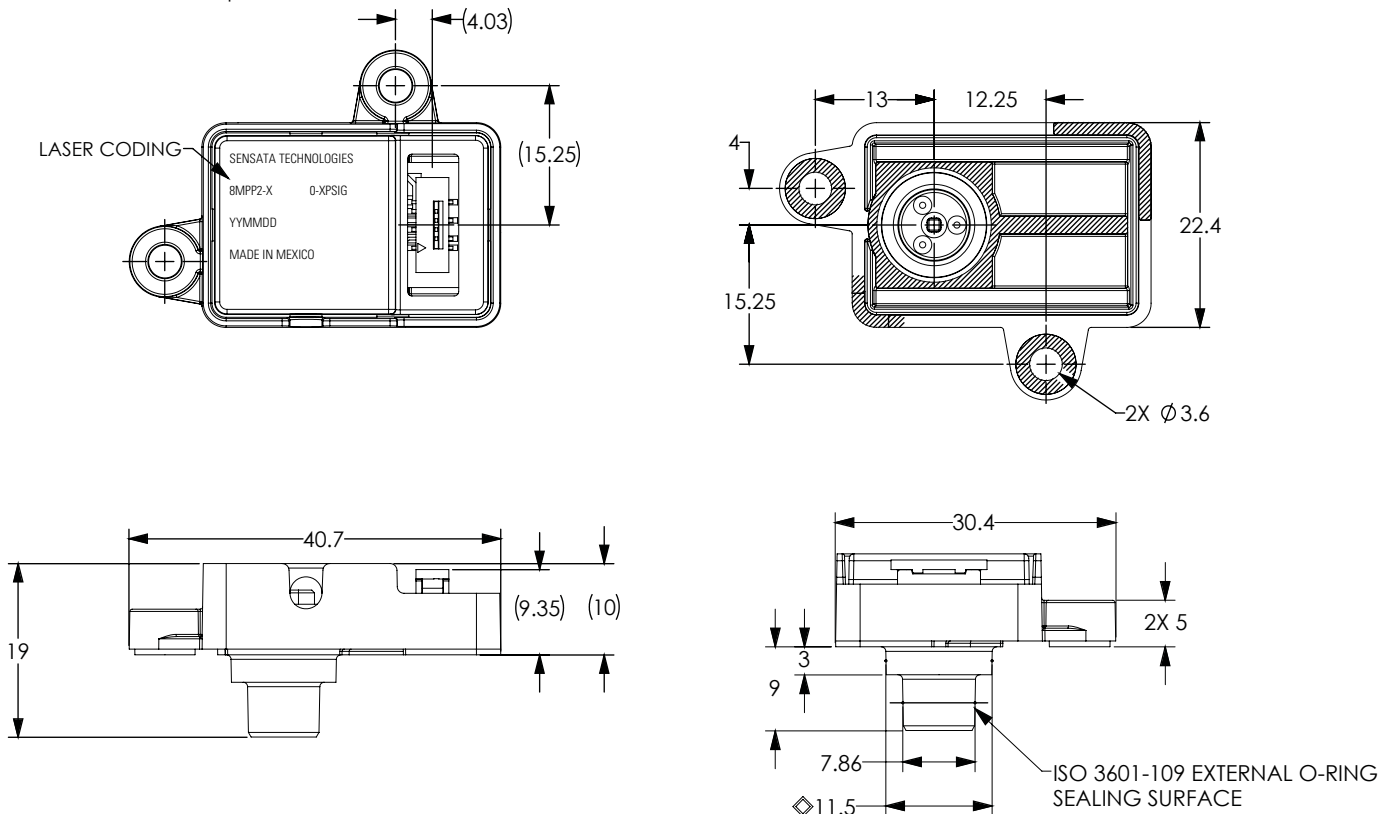



# CUSTOMER INTERFACE

## Mating Geometry

MATING MATERIAL: CAST AI

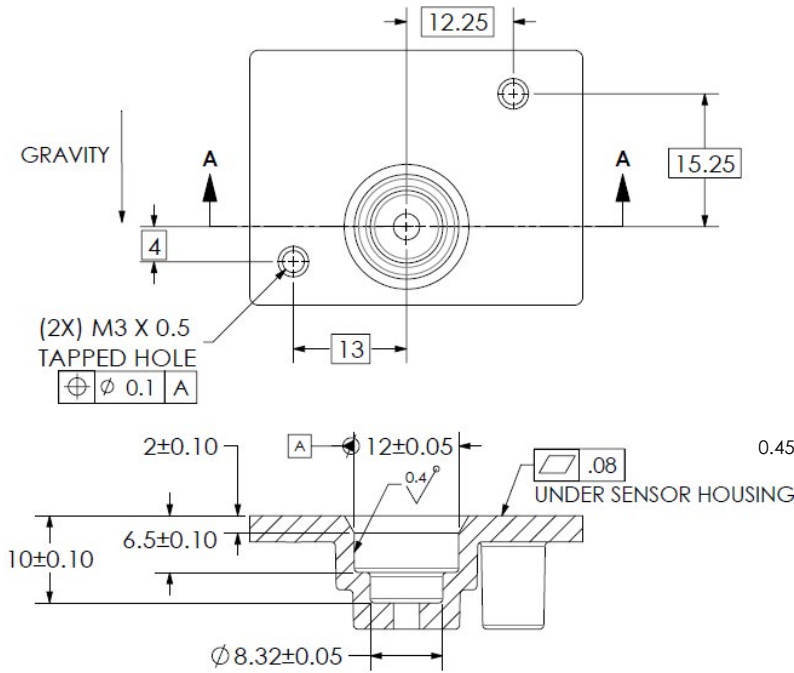

SECTION A-A

HARDWARE INSTALLATION TORQUE:  
7 IN-LB (1.20 N-mm) MAX

CONNECTOR TYPE: 4 POS FFC CONNECTOR  
 PIN 1 LOCATION  
 MANUFACTURER: AMPHENOL  
 MANUFACTURER P/N: SFW4S-2STM AE1LF  
 SINGLE SIDED GOLD CONTACTS

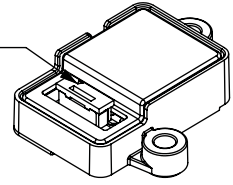

RECOMMENDED CABLE GEOMETRY

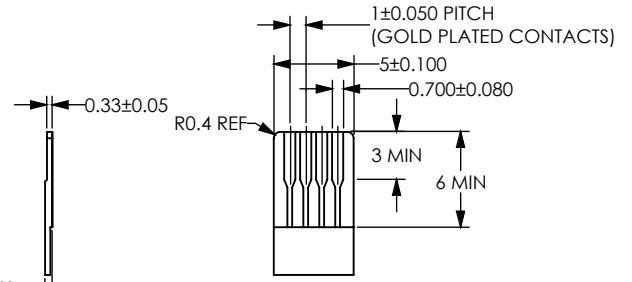

## Connector Pinout

PIN	Output
1	SCL
2	SDA
3	VSUP
4	GND



## ORDERING OPTIONS

Example : 8MPP2-01-0x28-U-0

1 psig, 0x28 I<sup>2</sup>C address, update mode, 0.5ms update rate

Part numbering for samples

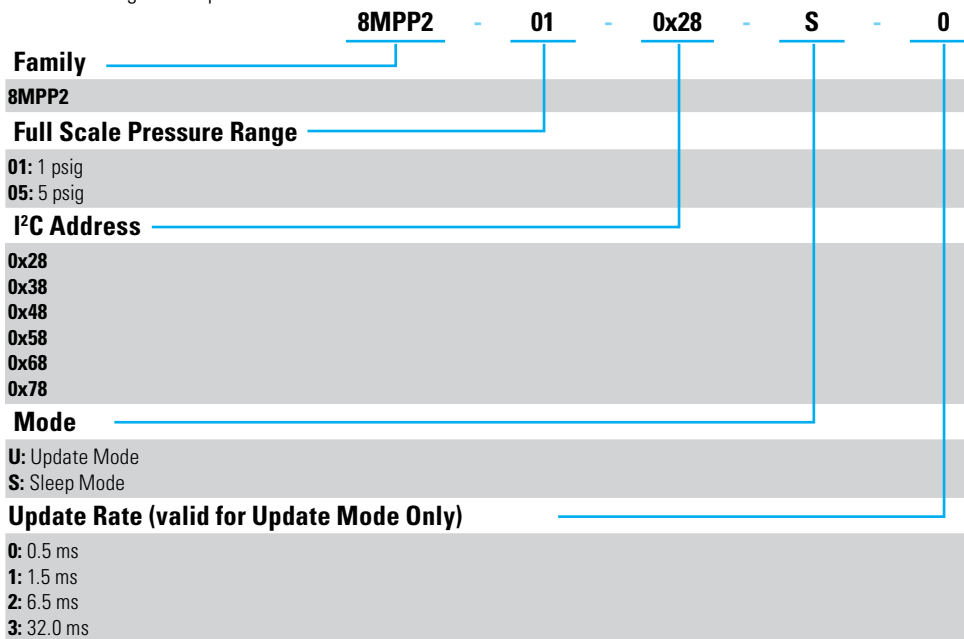



# AGENCY APPROVALS & CERTIFICATIONS



## I<sup>2</sup>C COMMUNICATION

I <sup>2</sup> C INTERFACE OVER TEMPERATURE RANGE						
<b>OUTPUT</b>						
RESOLUTION	12 BITS MIN					
UPDATE RATE (SEE NOTE 3)	1.5ms					
<b>VOLTAGE</b>	<b>SYMBOL</b>	<b>CONDITIONS</b>	<b>MIN</b>	<b>TYP</b>	<b>MAX</b>	<b>UNITS</b>
HIGH-LEVEL INPUT VOLTAGE	V <sub>IH</sub>	-	0.8 × V <sub>DD</sub>	-	V <sub>DD</sub>	V
LOW-LEVEL INPUT VOLTAGE	V <sub>IL</sub>	-	-	-	0.2 × V <sub>DD</sub>	V
HIGH-LEVEL OUTPUT VOLTAGE	V <sub>OH</sub>	-	V <sub>DD</sub> - 0.2	-	V <sub>DD</sub>	V
LOW-LEVEL OUTPUT VOLTAGE	V <sub>OL</sub>	-	0	-	0.2	V
<b>PARAMETER</b>						
OUTPUT SINK CURRENT	I <sub>OL, SDA</sub>	SDA @ V <sub>OL</sub> , MAX	2.3	3.9	6.2	mA
LOAD CAPACITANCE AT SDA	C <sub>SDA</sub>	@400kHz	-	-	200	pF
PULL-UP RESISTOR	R <sub>PC, PU</sub>	-	0.5	1	50	kΩ
INPUT CAPACITANCE	C <sub>PC, IN</sub>	-	-	-	10	pF

PARAMETER	SYMBOL	MIN	TYP	MAX	UNITS
SCL clock frequency	f <sub>SCL</sub>	100		400	kHz
Start condition hold time relative to SCL edge	t <sub>HDSTA</sub>	0.1			μs
Minimum SCL clock low width <sup>1)</sup>	t <sub>LOW</sub>	0.6			μs
Minimum SCL clock high width <sup>1)</sup>	t <sub>HIGH</sub>	0.6			μs
Start condition setup time relative to SCL edge	t <sub>SUSTA</sub>	0.1			μs
Data hold time on SDA relative to SCL edge	t <sub>HDDAT</sub>	0			μs
Data setup time on SDA relative to SCL edge	t <sub>SUDAT</sub>	0.1			μs
Stop condition setup time on SCL	t <sub>SUSTO</sub>	0.1			μs
Bus free time between stop condition and start condition	t <sub>BUS</sub>	2			μs

1) Combined low and high widths must equal or exceed minimum SCLK period

5. NO EXTERNAL CAPACITANCE NEEDED FOR V<sub>S</sub>

### NOTES:

1. THE SDA SIGNAL IS OPEN DRAIN. IT REQUIRES AN EXTERNAL PULL-UP SIZED TO MEET THE SPECIFIED TIMING REQUIREMENTS
2. LIMITS ON LOAD CAPACITANCE, PULL-UP RESISTOR, AND INPUT PIN CAPACITANCE ARE PROVIDED IN THE CASE WHERE MULTIPLE SLAVES ARE ON THE I<sup>2</sup>C B
3. UPDATE RATE IS THE TIME INTERVAL BETWEEN NEW MEASUREMENTS WHEN THE SENSOR IS POWERED CONTINUOUSLY.
4. SCL IS INPUT ONLY. SENSOR IS A SLAVE ONLY AND DOES NOT CREATE ANY CLOCK STRETCHING OR MULTIMASTER.

### TIMING DIAGRAM OVER TEMPERATURE RANGE:

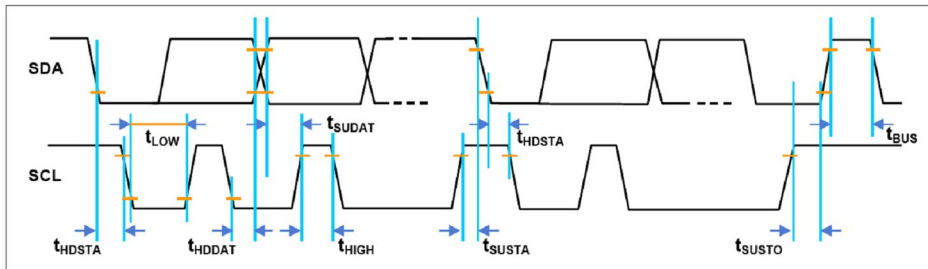

NOTE: THERE ARE THREE ADJUSTMENTS TO THE I<sup>2</sup>C IMPLEMENTATION COMPARED WITH THE ORIGINAL I<sup>2</sup>C PROTOCOL:

- SENDING A START-STOP CONDITION WITHOUT ANY TRANSITIONS ON THE CLK LINE (NO CLOCK PULSES IN BETWEEN) CREATES A COMMUNICATION ERROR FOR THE NEXT COMMUNICATION, EVEN IF THE NEXT START CONDITION IS CORRECT AND THE CLOCK PULSE IS APPLIED. AN ADDITIONAL START CONDITION MUST BE SENT, WHICH RESULTS IN RESTORATION OF PROPER COMMUNICATION.
- THE RESTART CONDITION- A FALLING SDA EDGE DURING DATA TRANSMISSION WHEN THE CLK CLOCK LINE IS STILL HIGH- CREATES THE SAME SITUATION. THE NEXT COMMUNICATION FAILS, AND AN ADDITIONAL START CONDITION MUST BE SENT FOR THE CORRECT COMMUNICATION.
- A FALLING SDA EDGE IS NOT ALLOWED BETWEEN THE START CONDITION AND THE FIRST RISING SCL EDGE. IF USING AN I<sup>2</sup>C ADDRESS WITH THE FIRST BIT 0, SDA MUST BE HELD 0W FROM THE START CONDITION THROUGH THE FIRST BIT.

I<sup>2</sup>C ADDRESS: 0x28 (IPSI)

I<sup>2</sup>C COMMUNICATION:

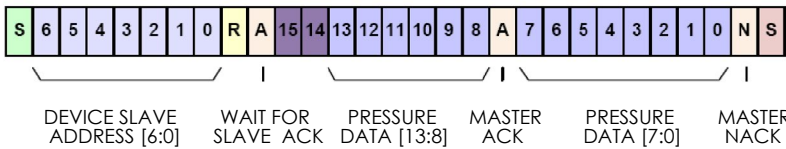

- S Start Condition
- 5 Device Slave Address (example: Bit 5)
- 2 Data Bit (example: Bit 2)
- R Read/Write Bit (example: Read=1)
- A Acknowledge (ACK)
- N No Acknowledge (NACK)
- S Stop Condition
- Status Bit

STATUS BITS (2 MSB OF OUTPUT PACKAGE)	DEFINITION
00	NORMAL OPERATION, GOOD DATA PACKET
01	RESERVED (WILL NOT BE SEEN DURING OPERATION)
10	STALE DATA: DATA THAT HAS ALREADY BEEN FETCHED SINCE THE LAST MEASUREMENT CYCLE. NOTE: IF A DATA FETCH IS PERFORMED BEFORE OR DURING THE FIRST MEASUREMENT AFTER POWER-ON RESET, THEN "STALE" WILL BE RETURNED, BUT THIS DATA IS ACTUALLY INVALID BECAUSE THE FIRST MEASUREMENT HAS NOT BEEN COMPLETED.
11	NOT USED

SPECIFICATION	MIN	MAX
SDA AND SCL RISE TIME	20ns	300ns
SDA AND SCL FALL TIME	12ns	300ns



## WARNINGS



### RISK OF MATERIAL DAMAGE AND HOT ENCLOSURE

- The product's side panels may be hot, allow the product to cool before touching
  - Follow proper mounting instructions including torque values
  - Do not allow liquids or foreign objects to enter this product
- Failure to follow these instructions can result in serious injury, or equipment damage.**



### HAZARD OF ELECTRIC SHOCK, EXPLOSION OR ARC FLASH

- Disconnect all power before installing or working with this equipment
  - Verify all connections and replace all covers before turning on power
- Failure to follow these instructions will result in death or serious injury.**

Sensata Technologies, Inc. ("Sensata") data sheets are solely intended to assist designers ("Buyers") who are developing systems that incorporate Sensata products (also referred to herein as "components"). Buyer understands and agrees that Buyer remains responsible for using its independent analysis, evaluation and judgment in designing Buyer's systems and products. Sensata data sheets have been created using standard laboratory conditions and engineering practices. Sensata has not conducted any testing other than that specifically described in the published documentation for a particular data sheet. Sensata may make corrections, enhancements, improvements and other changes to its data sheets or components without notice.

Buyers are authorized to use Sensata data sheets with the Sensata component(s) identified in each particular data sheet. HOWEVER, NO OTHER LICENSE, EXPRESS OR IMPLIED, BY ESTOPPEL OR OTHERWISE TO ANY OTHER SENSATA INTELLECTUAL PROPERTY RIGHT, AND NO LICENSE TO ANY THIRD PARTY TECHNOLOGY OR INTELLECTUAL PROPERTY RIGHT, IS GRANTED HEREIN. SENSATA DATA SHEETS ARE PROVIDED "AS IS". SENSATA MAKES NO WARRANTIES OR REPRESENTATIONS WITH REGARD TO THE DATA SHEETS OR USE OF THE DATA SHEETS, EXPRESS, IMPLIED OR STATUTORY, INCLUDING ACCURACY OR COMPLETENESS. SENSATA DISCLAIMS ANY WARRANTY OF TITLE AND ANY IMPLIED WARRANTIES OF MERCHANTABILITY, FITNESS FOR A PARTICULAR PURPOSE, QUIET ENJOYMENT, QUIET POSSESSION, AND NON-INFRINGEMENT OF ANY THIRD PARTY INTELLECTUAL PROPERTY RIGHTS WITH REGARD TO SENSATA DATA SHEETS OR USE THEREOF.

All products are sold subject to Sensata's terms and conditions of sale supplied at [www.sensata.com](http://www.sensata.com) SENSATA ASSUMES NO LIABILITY FOR APPLICATIONS ASSISTANCE OR THE DESIGN OF BUYERS' PRODUCTS. BUYER ACKNOWLEDGES AND AGREES THAT IT IS SOLELY RESPONSIBLE FOR COMPLIANCE WITH ALL LEGAL, REGULATORY AND SAFETY-RELATED REQUIREMENTS CONCERNING ITS PRODUCTS, AND ANY USE OF SENSATA COMPONENTS IN ITS APPLICATIONS, NOTWITHSTANDING ANY APPLICATIONS-RELATED INFORMATION OR SUPPORT THAT MAY BE PROVIDED BY SENSATA.

Mailing Address: Sensata Technologies, Inc., 529 Pleasant Street, Attleboro, MA 02703, USA.

## CONTACT US

### Americas

+1 (800) 350 2727  
sensors@sensata.com  
switches@sensata.com

### Europe, Middle East & Africa

+359 (2) 809 1826  
pressure-info.eu@sensata.com

### Asia Pacific

sales.isasia@list.sensata.com  
China +86 (21) 2306 1500  
Japan +81 (45) 277 7117  
Korea +82 (31) 601 2004  
India +91 (80) 67920890  
Rest of Asia +886 (2) 27602006  
ext 2808

## X-ON Electronics

Largest Supplier of Electrical and Electronic Components

*Click to view similar products for [Board Mount Pressure Sensors](#) category:*

*Click to view products by [Sensata](#) manufacturer:*

Other Similar products are found below :

[6407-249V-17343P](#) [6407-250V-09273P](#) [6407-250V-09343P](#) [80527-25.0H2-05](#) [80541-B00000150-01](#) [80541-B00000200-05](#) [80554-00700100-05](#) [80568-00300050-01](#) [93.631.4253.0](#) [93.731.4353.0](#) [93.932.4553.0](#) [136PC15A1](#) [142PC95AW71](#) [142PC05DW70](#) [15PSI-G-4V](#) [1805-01A-L0N-B](#) [26PCBKT](#) [26PCCFA6D26](#) [26PCCFS2G](#) [26PCCVA6D](#) [93.632.7353.0](#) [93.731.3653.0](#) [93.931.4853.0](#) [93.932.4853.0](#) [SDP510-500PA](#) [185PC30DH](#) [20INCH-G-MV-MINI](#) [26PCAFJ3G](#) [26PCCEP5G24](#) [26PCCFJ3G](#) [26PCDFA3G](#) [26PCJEU5G19](#) [30INCH-D1-MV-MINI](#) [ASCX15AN-90](#) [ASCX15AN/SZ76114](#) [4426-015G](#) [4525-DS5A030DP](#) [DCAL401DN](#) [DCAL401GN](#) [4515-DS5A020DP](#) [XZ202798SSC](#) [XZ203676HSC](#) [6407-249V-09273P](#) [6407-249V-09343P](#) [6407-249V-17273P](#) [6407-250V-17273P](#) [6407-250V-17343P](#) [81717-00000050-05](#) [81794-B00001200-01](#) [82681-B00000100-01](#)