

SENSITRON
SEMICONDUCTOR

1N6620/U/US thru 1N6625/U/US
ULTRAFAST RECOVERY RECTIFIER

TECHNICAL DATA
DATA SHEET 5089, REV. A.3

AVAILABLE AS
1N, JAN, JANTX, JANTXV
JANS

Ultrafast Recovery Rectifier
Qualified per MIL-PRF-19500/585

- Hermetic, non-cavity glass package
- Metallurgically bonded
- Operating and storage temperature: -65°C to +175°
- All parts are 100% hot solder dipped
- JAN/ JANTX/ JANTXV available per MIL-PRF-19500/585

MAX. RATINGS / ELECTRICAL CHARACTERISTICS All ratings are at $T_A = 25^\circ\text{C}$ unless otherwise specified.

Rating	Symbol	Condition	Max	Units
WORKING PEAK REVERSE VOLTAGE 1N6620, U, US 1N6621, U, US 1N6622, U, US 1N6623, U, US 1N6624, U, US 1N6625, U, US	V_{RWM}		200 400 600 800 900 1000	Volts
AVERAGE RECTIFIED FORWARD CURRENT 1N6620, U, US thru 1N6622, U, US 1N6623, U, US thru 1N6625, U, US	I_o		1.2 1.0	Amps
PEAK FORWARD SURGE CURRENT 1N6620, U, US thru 1N6624, U, US 1N6625, U, US	I_{FSM}	$T_p=8.3\text{ms}$	20 15	A(pk)
MAXIMUM REVERSE CURRENT 1N6620, U, US thru 1N6624, U, US 1N6625, U, US	$I_R @ V_{RWM}$	$T_j = 25^\circ\text{C}$	0.5 1.0	μAmps
MAXIMUM REVERSE CURRENT 1N6620, U, US thru 1N6624, U, US 1N6625, U, US	$I_R @ V_{RWM}$	$T_j = 150^\circ\text{C}$	150 200	μAmps
MAX. PEAK FORWARD VOLTAGE (PULSED) 1N6620, U, US thru 1N6622, U, US 1N6623, U, US & 1N6624, U, US 1N6625, U, US	V_{FM}	$I_F=2.0\text{A}$ $I_F=1.5\mu\text{A}$ $I_F=1.5\mu\text{A}$	1.60 1.80 1.95	Volts
PEAK RECOVERY CURRENT 1N6620, U, US thru 1N6622, U, US 1N6623, U, US & 1N6624, U, US 1N6625, U, US	I_{RM}	$I_F=2\text{A}$, 100A/ μ	3.5 4.2 5.0	A(pk)
MAXIMUM REVERSE RECOVERY TIME 1N6620, U, US thru 1N6622, U, US 1N6623, U, US & 1N6624, U, US 1N6625, U, US	T_{rr}	$I_F=0.5\text{A}$ $I_{RM}=1.0\text{A}$	30 50 60	ns
FORWARD RECOVERY VOLTAGE 1N6620, U, US thru 1N6622, U, US 1N6623, U, US & 1N6624, U, US 1N6625, U, US	V_{FRM}	$I_F=0.5\text{A}$ $t_r=12\text{ns}$	12 18 30	Volts
THERMAL RESISTANCE (Axial) 1N6620 thru 1N6625	$R_{\theta_{JL}}$	$L=.375$	38	$^\circ\text{C/W}$
THERMAL RESISTANCE (MELF) 1N6620U,US thru 1N6625U,US	$R_{\theta_{JEC}}$	$L=0$	13	$^\circ\text{C/W}$

*Sensitron equivalent diodes are manufactured and screened to MIL-PRF-19500 flow and guidelines starting from wafer fabrication through assembly and testing using our specification 7700-4093.

TECHNICAL DATA
DATA SHEET 5089, REV. A.3

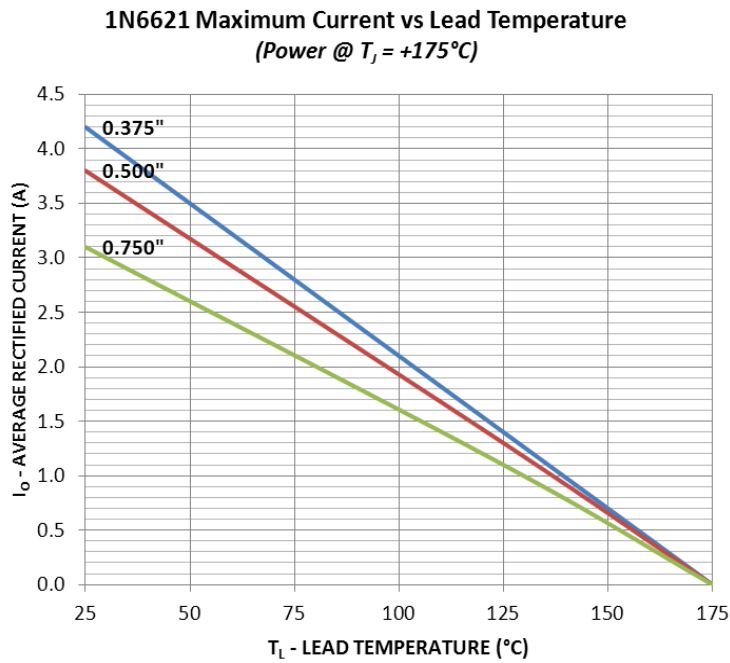
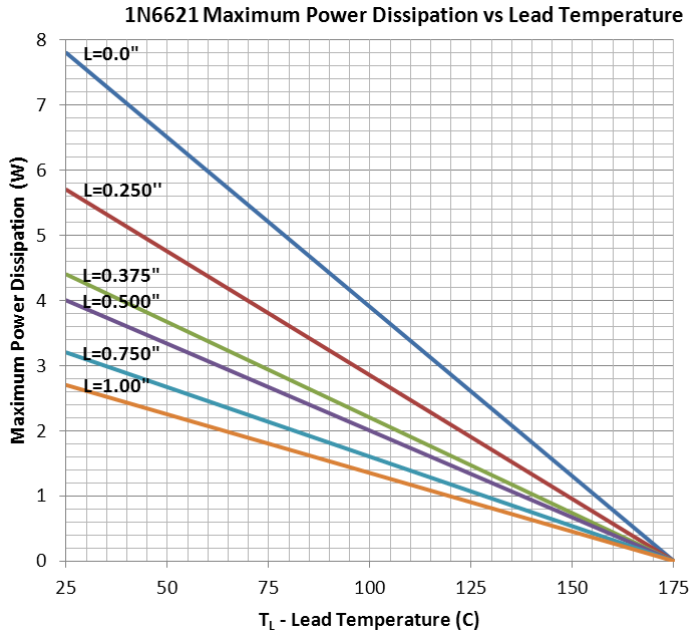

TECHNICAL DATA
DATA SHEET 5089, REV. A.3

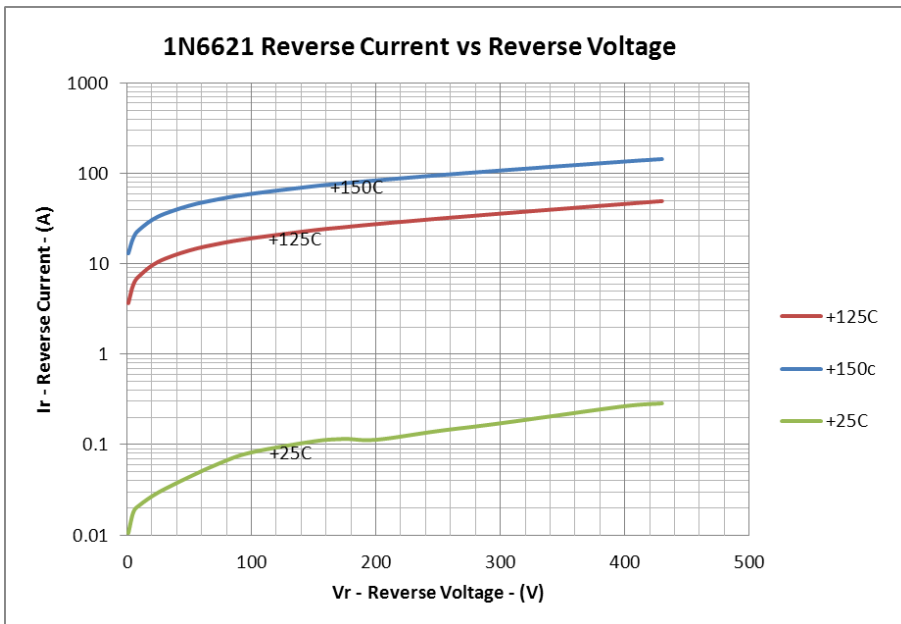
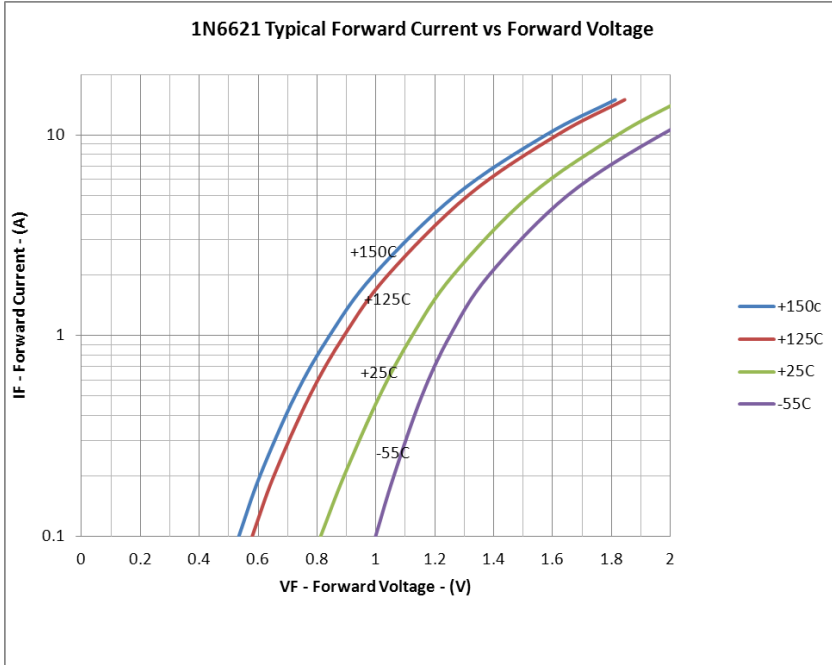

TECHNICAL DATA
DATA SHEET 5089, REV. A.3

MECHANICAL DIMENSIONS In Inches / (mm)

AXIAL

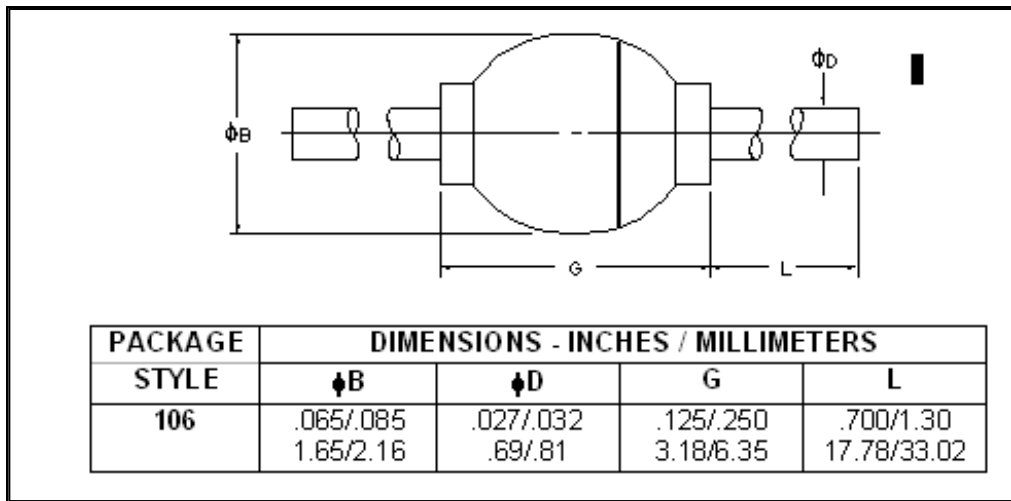

MELF (Add "U" or "US" to Part Number)

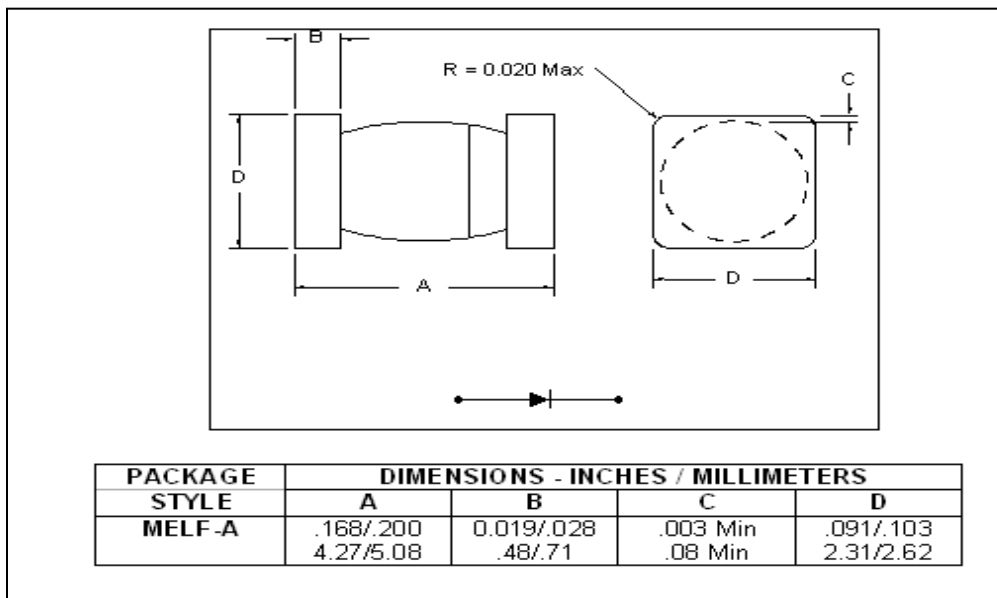

SENSITRON
SEMICONDUCTOR

1N6620/U/US thru 1N6625/U/US

**ULTRAFAST RECOVERY
RECTIFIER**

TECHNICAL DATA
DATA SHEET 5089, REV. A.3

The following part numbers can be purchased in either axial or surface mount devices and screened and tested to the military screening flow. The parts are marked in accordance with the testing performed, example:

Sensitron Screening Level	*Part Number-- Leaded Package (example for 1N6620)	*Part Number-- MELF Package (example for 1N6620)
1N	1N6620	1N6620US or 1N6620US
JAN	JAN1N6620	JAN1N6620US or JAN1N6620U
JANTX	JANTX1N6620	JANTX1N6620US or JANTX1N6620U
JANTXV	JANTXV1N6620	JANTXV1N6620US or JANTXV1N6620U
JANS	JANS1N6620	JANS1N6620US or JANS1N6620U

*Parts can also be ordered Tape & Reel

DISCLAIMER:

- 1- The information given herein, including the specifications and dimensions, is subject to change without prior notice to improve product characteristics. Before ordering, purchasers are advised to contact the Sensitron Semiconductor sales department for the latest version of the datasheet(s).
- 2- In cases where extremely high reliability is required (such as use in nuclear power control, aerospace and aviation, traffic equipment, medical equipment, and safety equipment), safety should be ensured by using semiconductor devices that feature assured safety or by means of users' fail-safe precautions or other arrangement.
- 3- In no event shall Sensitron Semiconductor be liable for any damages that may result from an accident or any other cause during operation of the user's units according to the datasheet(s). Sensitron Semiconductor assumes no responsibility for any intellectual property claims or any other problems that may result from applications of information, products or circuits described in the datasheets.
- 4- In no event shall Sensitron Semiconductor be liable for any failure in a semiconductor device or any secondary damage resulting from use at a value exceeding the absolute maximum rating.
- 5- No license is granted by the datasheet(s) under any patents or other rights of any third party or Sensitron Semiconductor.
- 6- The datasheet(s) may not be reproduced or duplicated, in any form, in whole or part, without the expressed written permission of Sensitron Semiconductor.
- 7- The products (technologies) described in the datasheet(s) are not to be provided to any party whose purpose in their application will hinder maintenance of international peace and safety nor are they to be applied to that purpose by their direct purchasers or any third party. When exporting these products (technologies), the necessary procedures are to be taken in accordance with related laws and regulations.

X-ON Electronics

Largest Supplier of Electrical and Electronic Components

Click to view similar products for [Rectifiers](#) category:

Click to view products by [Sensitron](#) manufacturer:

Other Similar products are found below :

[D91A](#) [DA24F4100L](#) [DD89N1600K-A](#) [DD89N16K-K](#) [RL252-TP](#) [DLA11C-TR-E](#) [DSA17G](#) [DSEI2X30-06C](#) [1N4005-TR](#) [BAV199-TP](#)
[UFS120Je3/TR13](#) [JANS1N6640US](#) [VS-80-1293](#) [DD89N16K](#) [DD89N16K-A](#) [481235F](#) [DSP10G-TR-E](#) [067907F](#) [MS306](#) [ND104N08K](#)
[SPA2003-B-D-A01](#) [VS-80-6193](#) [VS-66-9903](#) [VGF0136AB](#) [US2JFL-TP](#) [UFS105Je3/TR13](#) [A1N5404G-G](#) [ACGRA4007-HF](#) [ACGRB207-HF](#)
[RF301B2STL](#) [RF501B2STL](#) [UES1306](#) [UES1302](#) [BAV199E6433HTMA1](#) [ACGRC307-HF](#) [ACEFC304-HF](#) [JANTXV1N5660A](#) [UES1106](#)
[GS2K-LTP](#) [D126A45C](#) [D251N08B](#) [SCHJ22.5K](#) [SM100](#) [SCPA2](#) [SCH10000](#) [SDHD5K](#) [STTH20P035FP](#) [VS-8EWS12S-M3](#) [VS-](#)
[12FL100S10](#) [ACGRA4001-HF](#)