

SP100 Series Compensated Pressure Sensors

The SP100 pressure sensors are calibrated and digitally compensated silicon piezoresistive sensors with SPI interface. In addition to pressure, the sensors provide acceleration ('A' version sensors), temperature and supply voltage measurements. Each sensor has a unique electronic sensor ID, and has a built in self diagnosis system. The SP100 series of sensors can easily be used in a broad range of applications and interfaces directly to a micro controller without the need of any additional components.

SP100 series has excellent media compatibility due to a patented bulk micromachined triple stack sensor die design, utilizing buried piezoresistive elements and backside media access to pressure diaphragm. With this design the internal connectors and piezoresistive elements of the pressure bridge are isolated from the measurement media. The isolation is of great advantage in terms of sensor stability and reliability over a very long lifetime.

The SP100 pressure sensor design has been proven in harsh environment applications during a period of more than 10 years, making these sensors ideal choices for demanding applications where simple solutions are needed to quickly implement reliable and accurate pressure measurements.

SP100-7 and SP100-12 sensors belong to the medium pressure range of SP100 sensors.

SP100-7
SP100-7T
SP100-7A
SP100-7AT
SP100-12A

Edition 2009-06-03

Published by

Sensoror Technologies AS

P.O. Box 196

N-3192 Horten

Norway

© Sensoror Technologies AS 2009.

All Rights Reserved.

Information furnished by Sensoror Technologies is believed to be accurate and reliable. However, no responsibility is assumed by Sensoror Technologies for its use, nor for any infringements of patents or other rights of third parties that may result from its use. Sensoror Technologies reserves the right to make changes without further notice to any products herein. Sensoror Technologies makes no warranty, representation or guarantee regarding the suitability of its products for any particular purpose, nor does Sensoror Technologies assume any liability arising out of the application or use of any product or circuit, and specifically disclaims any and all liability, including without limitation consequential or incidental damages. No license is granted by implication or otherwise under any patent or patent rights of Sensoror Technologies. Trademarks and registered trademarks are the property of their respective owners. Sensoror Technologies products are not intended for any application in which the failure of the Sensoror Technologies product could create a situation where personal injury or death may occur. Should Buyer purchase or use Sensoror Technologies products for any such unintended or unauthorized application, Buyer shall indemnify and hold Sensoror Technologies and its officers, employees, subsidiaries, affiliates, and distributors harmless against all claims, costs, damages, and expenses, and reasonable legal fees arising out of, directly or indirectly, any claim of personal injury or death associated with such unintended or unauthorized use, even if such claim alleges that Sensoror Technologies was negligent regarding the design or manufacture of the part.



Table of Contents

- 1 Product Description - 4 -
 - 1.1 Features - 4 -
 - 1.2 Overview - 4 -
- 2 Measurement Performance - 5 -
 - 2.1 Pressure Measurement Performance - 5 -
 - 2.2 Temperature Measurement Performance - 5 -
 - 2.3 Acceleration Measurement Performance (option)..... - 6 -
 - 2.4 Supply Voltage Measurement Performance - 7 -
- 3 Recommended Operating Conditions - 7 -
- 4 Absolute Maximum Ratings - 7 -
- 5 Wake-Up and Reset Outputs - 8 -
- 6 Serial Interface - 8 -
 - 6.1 SPI Protocol..... - 8 -
 - 6.2 SPI Commands - 10 -
 - 6.3 SPI Timing Parameters - 10 -
 - 6.4 Status Byte - 11 -
 - 6.5 Temperature Byte..... - 11 -
 - 6.6 Pressure Byte - 11 -
 - 6.7 Supply Voltage Byte - 11 -
 - 6.8 Acceleration Byte..... - 11 -
- 7 Digital Output Characteristics - 11 -
- 8 Power-On Reset - 12 -
- 9 Current Consumption..... - 12 -
 - 9.1 Standby Current - 12 -
 - 9.2 Measurement Current - 12 -
- 10 Error Handling and Recovery - 12 -
 - 10.1 PROM Data - 12 -
 - 10.2 PROM Reload - 13 -
 - 10.3 Shadow Register Protection - 13 -
 - 10.4 Low Supply Voltage..... - 13 -
 - 10.5 High Temperature..... - 13 -
 - 10.6 Overflow/Underflow - 13 -
- 11 Mechanical Specifications - 14 -
 - 11.1 Physical Dimensions - 14 -
 - 11.2 Tube Connection (option) - 15 -
 - 11.3 Pin Configuration - 16 -
 - 11.4 Marking..... - 16 -



1 Product Description

1.1 Features

- Digital interface, SPI
- Absolute pressure sensor
- Calibrated and compensated
- Sensor self diagnosis
- Unique electronic sensor ID
- High reliability and accuracy over long lifetime
- High media compatibility
- Wide temperature operating range
- Temperature and supply voltage measurement
- Low standby current (0.3 μ A)
- Robust miniature surface mount package
- No external discrete components required
- On-chip accelerometer (option)
- High static acceleration and shock capability (2000 g)
- Tube connection (option)

1.2 Overview

SP100 is an integrated MEMS pressure sensor designed for air pressure measurements. The sensor has a digital interface designed for use in microcontroller applications. SP100 is housed in a 14 pin small outline package, and requires no external components. SP100 has an accelerometer for measuring acceleration (option for 'A' version sensors) and a tube connection (option for 'T' version sensors).

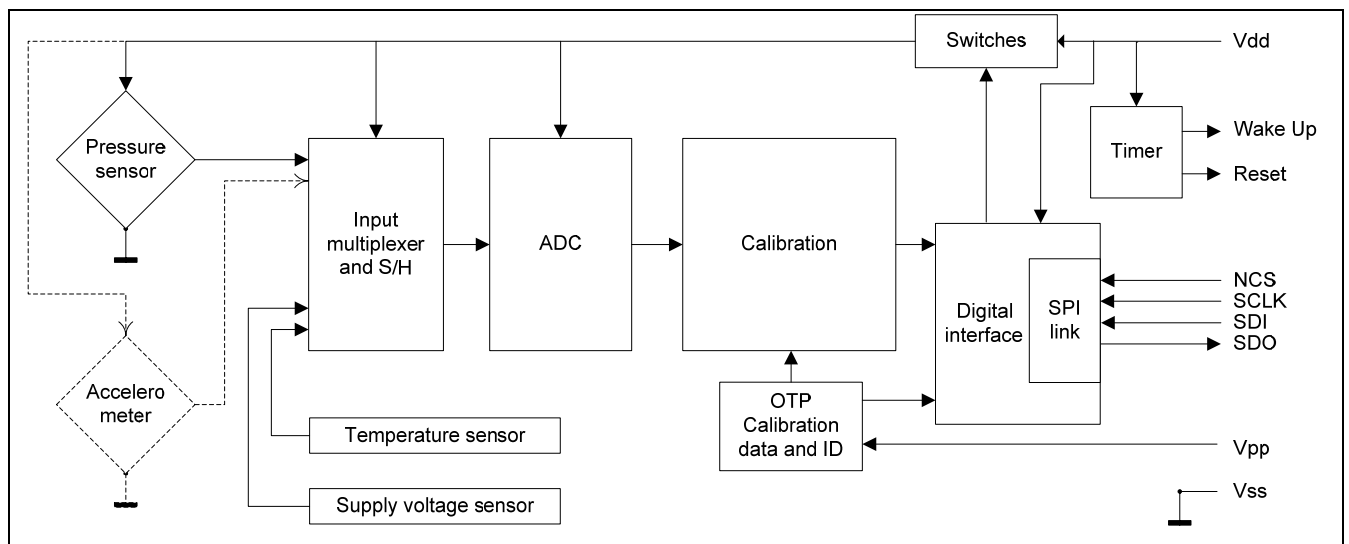

Figure 1.1 SP100 block diagram



2 Measurement Performance

The ADC of the sensor is an integrating charge balancing converter. Monotonic operation and no missing codes are guaranteed over the full operating range. All the following specification limits are to be understood as typical values unless otherwise is stated.

2.1 Pressure Measurement Performance

Parameter	Specification			Ambient conditions	
	Model	Unit	Typ	Temperature [°C]	Pressure [kPa]
Resolution	SP100-7 SP100-7T SP100-7A SP100-7AT	kPa/lb	1.25	-40 to 125	0 to 700
	SP100-12A	kPa/lb	1.25	-40 to 125	0 to 1200
Accuracy ₁₎	SP100-7 SP100-7T SP100-7A SP100-7AT	kPa	± 6.3	0 to 50	0 to 700
		kPa	± 7.8	-20 to 70	0 to 450
		kPa	± 11	-20 to 70	450 to 700
		kPa	± 15	-40 to 125	0 to 700
	SP100-12A	kPa	± 11	0 to 50	0 to 1000
		kPa	± 14	-40 to 125	0 to 1000
		kPa	± 20	0 to 50	1000 to 1200
		kPa	± 23	-40 to 125	1000 to 1200
Pressure measurement time	All	ms	6 (max)		

2.2 Temperature Measurement Performance

Parameter	Specification			Ambient conditions
	Model	Unit	Typ	Supply voltage [V]
Resolution	All	°C/lb	1	2.1 to 3.6
Accuracy	All	°C	± 2.4	2.5 to 3.6
		°C	± 3.0	2.5 to 3.6
		°C	± 4.8	2.5 to 3.6
		°C	± 4.2	2.1 to 2.5
		°C	± 6.0	2.1 to 2.5
Pressure measurement time	All	ms	1.5 (max)	2.1 to 3.6

The temperature read is known to have a deviation from actual temperature. A correction term is given by:

$$\Delta T_{corr} = -0.92 + 0.004 * T_{PRODUCT} + 0.0002 * T_{PRODUCT}^2$$

Where: T_{PRODUCT} is the temperature reported by the product, and Δ T_{corr} is the correction term. See Figure 2.1.

Δ T_{corr} should be subtracted from the reported temperature to achieve specified accuracy.

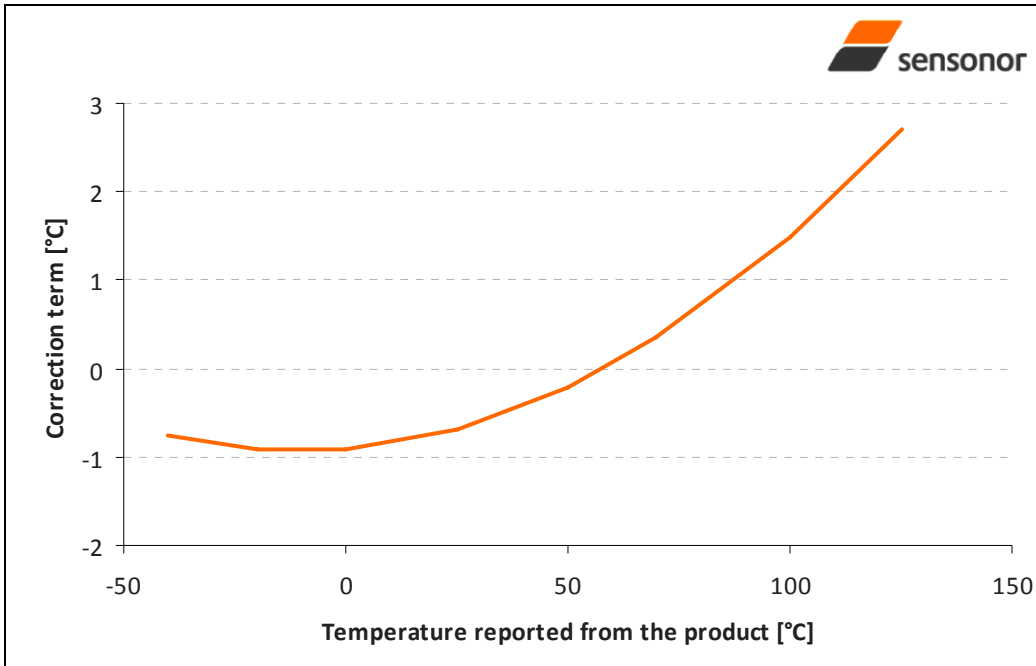

Figure 2.1 Temperature correction term

2.3 Acceleration Measurement Performance (option)

The SP100 devices with 'A' in the model name feature an on-chip accelerometer sensor for acceleration measurements.

All accelerometer specifications are valid when sensors are not subject to electrostatic charge.

Table 2.1 Acceleration measurement performance (option)

Parameter	Specification			Ambient conditions	
	Model	Unit	Typ	Temperature [°C]	Supply voltage [V]
Resolution	SP100-7A SP100-7AT SP100-12A	g/lsb	0.5	-40 to 125	2.1 to 3.6
Sensitivity accuracy	SP100-7A SP100-7AT SP100-12A	%	± 11	-40 to 90	2.1 to 3.6
		%	± 14	90 to 125	2.1 to 3.6
Offset	SP100-7A SP100-7AT SP100-12A	g	± 3.6	25	2.1 to 3.6
		g	± 5.3	-40 to 90	2.1 to 3.6
		g	± 7.2	90 to 125	2.1 to 3.6
Random error ₁₎	SP100-7A SP100-7AT SP100-12A	g	± 2	-40 to 90	-
		g	± 4	90 to 125	-
Acceleration measurement time	SP100-7A SP100-7AT SP100-12A	ms	6 (max)	-40 to 125	2.1 to 3.6

Note:

1) Including quantification error, noise and repeatability.



2.4 Supply Voltage Measurement Performance

Parameter	Specification			Ambient conditions
	Model	Unit	Typ	Supply voltage [V]
Input range ¹⁾	All	V	1.8 – 3.6	2.1 to 3.6
Resolution	All	mV/lsb	18.4	2.1 to 3.6
Accuracy	All	mV	± 60	2.1 to 3.6
Delay between measurement command and sampling	All	ms	3.5	-
Delay between sampling and A/D conversion	All	ms	10	-
Supply voltage measurement total time	All	ms	17 (max)	2.1 to 3.6

Note:

- 1) The sampling operates down to 1.8 V. The specification applies to the A/D-conversion.

3 Recommended Operating Conditions

Description	Min	Typ	Max	Units
Temperature range, operational	-40		+125	°C
Supply voltage during measurement ¹⁾	2.1		3.6	V
Supply voltage between measurements	1.8		5.5	V
Input pressure ²⁾	SP100-7 SP100-7T SP100-7A SP100-7AT	0	700	kPa
	SP100-12A	0	1200	kPa
Static acceleration			2000	g

Notes:

- 1) This is the voltage range where measurement accuracy is specified.
- 2) All pressure values given in this specification are absolute values.

4 Absolute Maximum Ratings

Description	Min	Typ	Max	Units
Input pressure			1600	kPa
Temperature ¹⁾	-40		+150	°C
Temperature transient ²⁾	-40		+175	°C
Storage temperature ³⁾	-40		+150	°C
Supply voltage	-0.3		6.0	V
Input voltage, any pin	-0.3		VDD + 0.3	V
Input current, any pin (transient)	-100		+100	mA
ESD protection (human body model) ⁴⁾	±2000V to any pin			
ESD protection (charge device model) ⁵⁾	±500V to any pin			
Mechanical shock			2000	g

Notes:

- 1) The component will also withstand standard reflow soldering, accumulated time < 2.5 hours.
- 2) Less than 3 min.
- 3) Accumulated time at 150°C not to exceed 500hours to avoid permanent damage. Solder ability may be affected with less exposure.
- 4) According to AEC-Q100-002 Rev. C or JESD22-A114 Rev. F
- 5) According to AEC-Q100-011 Rev. B or JESD22-C101 Rev. D

Prolonged exposure to values between recommended operating conditions and absolute maximum ratings might affect the performance and reliability of the device.



5 Wake-Up and Reset Outputs

The product provides two outputs, which may be used to interrupt or reset a microcontroller. Each output provides a pulse at regular intervals. The “wake-up and reset” are active low outputs. The Wake Up period typical value is programmable from 1 to 256 seconds, in 1 second intervals.

Table 5.1 Wake-up and reset outputs

Parameter	Min	Typ	Max	Unit
Wake Up Width	0.13		2.5	ms
Reset period		51		min
Reset width	0.13		2.5	ms
Interval timing drift over temperature ¹⁾		0.6	1	%/°C
Interval timing drift over supply voltage ¹⁾		-15	-40	%/V

Notes:

- 1) See text describing oscillators below.

The product has two oscillators: One low-power oscillator, which runs at about 2.5 kHz and is used for interval timing, and a 2 MHz oscillator used for measurements and data transmission. Due to its very low current consumption, the low-power oscillator is sensitive to temperature and supply voltage variation. To keep the interval lengths constant under different conditions, the low-power oscillator is compared to the 2 MHz oscillator during each measurement, and a correction is applied to the interval count. This operation is called an auto calibration. The stability of the interval depends on the change in temperature or supply voltage since the last measurement.

6 Serial Interface

The SPI interface is the communication protocol to the external microcontroller. This maximum serial clock frequency is 500 kHz.

The SPI consists of a shift register, a command latch and failure latches, and encoder/decoder logic.

6.1 SPI Protocol

When NCS is high, any signals at the *SCLK* and *SDI* pins are ignored, and *SDO* is forced into a high impedance state.

During the *NCS* high-to-low transition, the SPI response word is multiplexed from the latch(es) that was(were) defined by the last command present in the shift register. The *SCLK* pin must be low when *NCS* goes low.

At each clock rising edge after *NCS* has gone low, the response word is serially shifted out of the ASIC at the *SDO* pin, LSB first. At each clock falling edge after *NCS* has gone low, the new control word is serially shifted into the ASIC at the *SDI* pin, LSB first.

The command bits of the received SPI word are then decoded to determine the destination address for the data bits. After the 8th clock falling edge has occurred, the following *NCS* low-to-high transition causes the data bits stored in the ASIC SPI shift register to be transferred into the latch which address was decoded from the SPI shift register command bits.

If the number of clock pulses before *NCS* goes high is different from 0, 8 or 16, a digital filter prevents execution of the received command (A valid *NCS* pulse with 0 clock pulses will cause the previous command to be executed again).

The Failure Status Indicator (FSI) is the logical OR of all bits in the status register, except bit 6.

The FSI appears at the *SDO* pin after *NCS* has gone low and before *SCLK* goes high (see timing diagram).



6.2 SPI Commands

Command	Code	Address	Response	Description
MEASURE_A	1000 0101		Read back command code	Measure acceleration
RCAD	1000 0000		Compensated acceleration data	Read compensated acceleration data (for 'A' models only)
RRADH	1000 0001		Raw acceleration data, high byte	Read raw acceleration data, high byte (for 'A' models only)
RRADL	1000 0011		Raw acceleration data, low byte	Read raw acceleration data, low byte (for 'A' models only)
MEASURE_P	0011 0001		Read back command code	Measure pressure
RCPDH	0010 1100		Compensated pressure data, high byte	Read compensated pressure data, high byte
RCPDL	0010 1101		Compensated pressure data, low byte	Read compensated pressure data, low byte
RRPDH	0000 1000		Raw pressure data, high byte	Read raw pressure data, high byte
RRPDL	0000 0100		Raw pressure data, low byte	Read raw pressure data, low byte
READIDH	0011 1101		ID, high byte	Read ID, high byte
READIDM	0011 1000		ID, mid byte	Read ID, mid byte
READIDL	0011 0100		ID, low byte	Read ID, low byte
MEASURE_B	0010 0101		Read back command code	Measure battery voltage
RCBD	0010 1001		Compensated supply data	Read compensated supply data
MEASURE_T	1010 1101		Read back command code	Measure temperature
RCTMP	1011 0000		Compensated temperature data	Read compensated temperature
RSR	1011 0101		Common general Status register (see byte description below)	Read common general status register
READ	1011 1000	A	One byte of shadow register	Read one byte of shadow register (OTP coefficients)
OTP_PWR	1111 0110	A	Read back command code	Turn OTP power on/off
RADDR	1100 0001		Read register at applied address	Read applied address (test of SPI)
STANDBY	0000 0001		Last response repeated	Go in Stand-by mode and shift out the response from the previous measurement command
LDOTP	1011 1100		Read back command code	Reset of product: Load OTP content to shadow register.
SETWK ₁₎	0010 1110	A	Read back command code	Set length of WAKEUP interval in address field (1 - 256 s)
GETWK	0010 1111		Programmed value of wakeup interval (0-255)	Read back length of wakeup interval

Notes:

- 1) This command is expected with parameter in front (one byte, LSB first).

6.3 SPI Timing Parameters

SPI (Load capacitor at SDO = 300pF)		Min	Max	Unit
fSCLK	Max. allowed application frequency (50% duty cycle)		500	kHz
tSDO_trans	SDO transition speed, 20% to 80% (with 60pF load capacitor)	5	25	ns
tclh	Minimum time SCLK = HIGH	100		ns
tcll	Minimum time SCLK = LOW	100		ns
tpcid	Propagation delay (SCLK to data edge at SDO valid)		100	ns
tcsdv	NCS = LOW to data edge at SDO active		100	ns
tsclch	SCLK low before NCS low (setup time SCLK to NCS edge H/L)	100		ns
thclcl	SCLK edge L/H after NCS edge H/L	100		ns
tsclcl	SDI input setup time (SCLK edge H/L after SDI data valid)	20		ns
thclcl	SDI input hold time (SDI data hold after SCLK edge H/L)		20	ns
tsclcl	SCLK low before NCS high	150		ns
thclch	SCLK high after NCS high	150		ns
tpchdz	NCS edge L/H to SDO at high impedance		100	ns
tonNCS	NCS min. high time	60		µs
	Capacitance at SDI, SDO, SCLK, NCS		10	pF
tfNCS	NCS filter time (Pulses shorter than tfNCS will be ignored)	10	100	ns
	NCS pulse filter ₁₎			

Note:

- 1) Digital filter for driver control register latch function. Output latch function is only enabled if positive NCS occurs after 8 CLK cycles (or a multiple of 8) since last negative NCS edge.



If an invalid command is received, no action will be taken and the response word will be all zeros (00 hex). Spare commands can be used for test mode if test mode can be disabled by hardware (test pin).

The three bytes of the ID (Identifier) code are programmed in the product PROM, giving the possibility for unique ID values for close to 16.8 million of sensors.

6.4 Status Byte

- Bit 0: Overflow/underflow
- Bit 1: Parity error in PROM data
- Bit 2: Checksum error in shadow register
- Bit 3: PROM reload / Internal Reset
- Bit 4: Unspecified measurement accuracy due to low supply voltage
- Bit 5: Sensor fault (Mechanical integrity of pressure and acceleration sensors and inter-chip bonding wires)
 - 0 = no error
 - 1 = pressure sensor or acceleration sensor or interchip bondwires broken
- Bit 6: Direction of positive acceleration for 'A' version sensors. (Not in use for SP100-7(T)). Not included in FSI calculation
- Bit 7: Measurement in progress:
 - 0 = Measurement completed, data can be read
 - 1 = Measurement in progress, data not available

6.5 Temperature Byte

The value in the temperature byte is (T+50), where T is temperature in °C. The allowed range (for which the accuracy is specified) for this byte is 10-175, corresponding to temperatures from -40 to 125°C. Remark: the temperature byte may show values outside this range, which have an undefined accuracy.

6.6 Pressure Byte

The pressure (in kPa) is obtained by multiplying the value in the pressure byte by the given resolution in kPa/lb (see section 2.1).

6.7 Supply Voltage Byte

The supply voltage (in V) is obtained by multiplying the value in the supply byte by 0.0184, and adding 1.73.

6.8 Acceleration Byte

(This is valid for 'A' version sensors.) The acceleration (in g) is obtained by multiplying the output by 0.5 and subtracting 12.

7 Digital Output Characteristics

These characteristics are valid for VDD 2.7V to 3.6V, temperature -40 to 125 °C , and load current less than 1 mA.

Table 7.1 Digital output characteristics

Description	Min	Typ	Max	Unit
Output logic low		0.1	0.2	V
Output logic high	VDD – 0.25	VDD – 0.13		V



8 Power-On Reset

To guarantee a power-on reset, VDD must be at 0 V for a minimum of 1 ms. This will cause a hardware reset, and start a 10 ms timer. After the 10 ms, a negative pulse on the RESET pin will be generated and the PROM will be read. If this is successful, the product will enter normal operation. If the PROM reading is not successful, error handling will be as described in section 10.

Table 8.1 Power-on reset specifications

Description	Min	Typ	Max	Unit
VDD level to initiate power-on reset			0	V
VDD level not to initiate power-on reset	1.0			V
VDD rise time (to 2.2V or higher)	0.1			µs
Power-on reset duration		22		ms
VDD required to complete power-on reset	2.2			V
Delay before power-on reset pulse	0.83		12.5	ms
Duration of power-on reset pulse	0.16		2.5	ms

9 Current Consumption

9.1 Standby Current

The standby current is the current drawn by the product when only the low-power oscillator and the interval counters are running.

9.2 Measurement Current

During measurement, various analog modules will be switched on and off as required, to minimize the total current consumption.

Table 9.1 Measurement current

Parameter	Comment	Typ	Max	Unit
Supply current in standby mode	25°C, 2.1 V	0.3	0.45	µA
	90°C, 2.1V	2	3	µA
	120°C, 2.1 V	11	16.5	µA
Supply current, all analog modules active	25°C, 2.1 V	2.1	2.9	mA
	90°C, 2.1 V	2.2	3.0	mA
	120°C, 2.1 V	2.2	3.1	mA
Supply current, digital activity incl. MCLK	25°C, 2.1 V	0.5	0.8	mA
	90°C, 2.1 V	0.5	0.8	mA
	120°C, 2.1 V	0.6	0.9	mA
Supply current in standby mode	25°C, 3V	0.4	0.6	µA
	90°C, 3 V	2.3	3.45	µA
	120°C, 3V	13	19.5	µA
Supply current, all analog modules active	25°C, 3V	2.7	3.5	mA
	90°C, 3V	2.8	3.7	mA
	120°C, 3V	2.8	3.8	mA
Supply current, digital activity incl. MCLK	25°C, 3V	0.6	1.0	mA
	90°C, 3V	0.6	1.1	mA
	120°C, 3V	0.7	1.2	mA

10 Error Handling and Recovery

10.1 PROM Data

The PROM contains calibration data and the identification code (ID). It is read at power-on reset, when its



contents are copied to the shadow register. The PROM contains one parity bit. If a parity error occurs during reading of the PROM, the product will enter the PROM Reload state, as described below.

10.2 PROM Reload

In this state, the product will read the PROM contents again with 1 s intervals until a successful read is completed. The PROM reading can fail for two reasons:

- Parity error in PROM data
- Reading not allowed due to supply voltage below minimum for read operation

If command via SPI is activated while the product is in the PROM reload/reset state, the FSI will be set.

10.3 Shadow Register Protection

After copying the PROM contents to the shadow register, a 16 bit CRC is calculated using the CCITT polynomial. This checksum is stored with the data, and is verified for each measurement cycle. If an error is detected, the product will return a single byte with an error code, and then enter PROM Reload / Reset state.

10.4 Low Supply Voltage

A supply voltage below 2.1 V (nominal) has two consequences:

- Reading of the PROM is not allowed
- The measurement accuracy cannot be guaranteed

The product uses a separate circuit with an output signal called VMIN, to detect this condition. VMIN = 1 will occur if $VDD < 2.1 \pm 0.1V$.

If low supply voltage causes the information in the shadow register to be corrupted, the product will enter PROM reload state as described in section 10.2.

10.5 High Temperature

If high temperature causes the information in the shadow register to be corrupted, the SP100 will enter PROM reload state as described in section 10.2.

10.6 Overflow/Underflow

The overflow bit will be set by an over- or underflow in the ADC or compensation module. For temperature and supply measurements, ADC overflow will not saturate the compensated output value.



11 Mechanical Specifications

11.1 Physical Dimensions

The sensor package is a proven 14 pin, SOIC package that can be handled by automatic production lines.

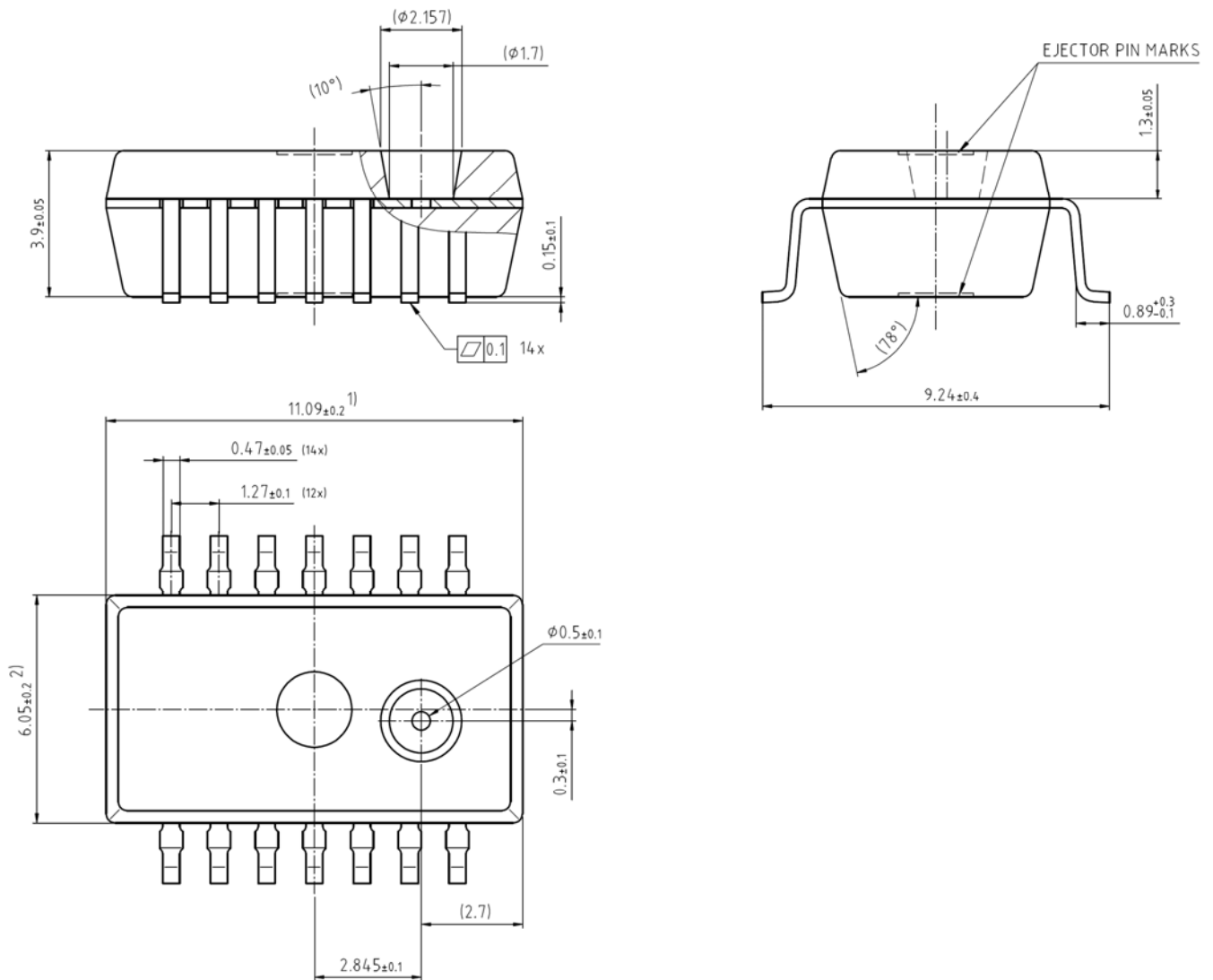

Figure 11.1 Physical dimensions drawing

- 1) Dimension does not include mold flash, protrusions or gate burrs. Mold flash, protrusions and gate burrs do not exceed 0.15mm (0.006 inch) per side.
- 2) Dimension does not include inter-lead flash or protrusions. Inter-lead flash and protrusions do not exceed 0.25mm (0.010 inch) per side.



11.2 Tube Connection (option)

The SP100 models with 'T' in the model name features two different tube connection options to ease pressure connection.

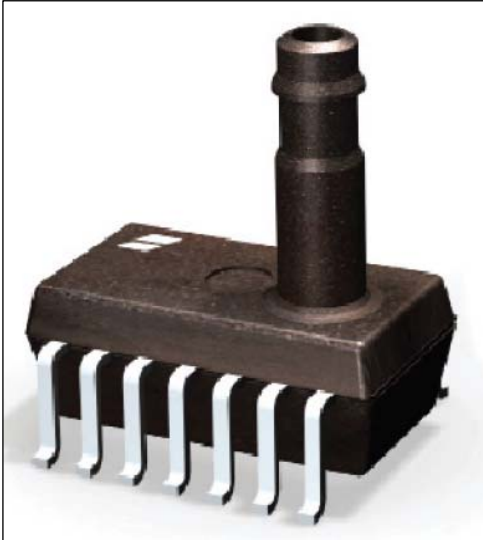

Figure 11.3 Illustration of the SP100 series with tube connection (type A)

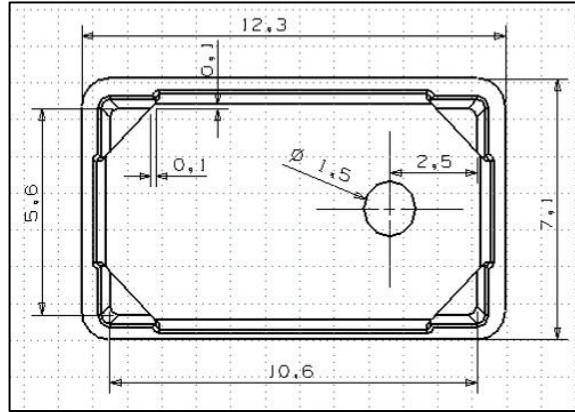

Figure 11.2 Mechanical drawing: Underside of tube connection (type A and type B)

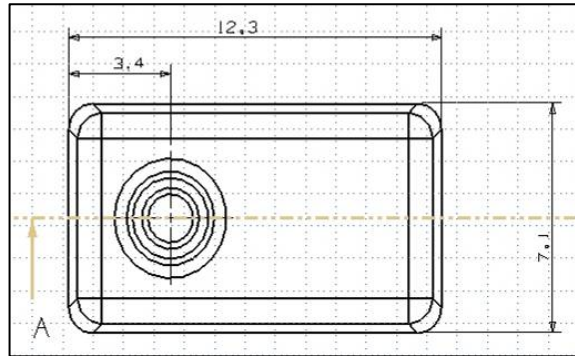

Figure 11.4 Mechanical drawing: Upside of tube connection (type A and B)

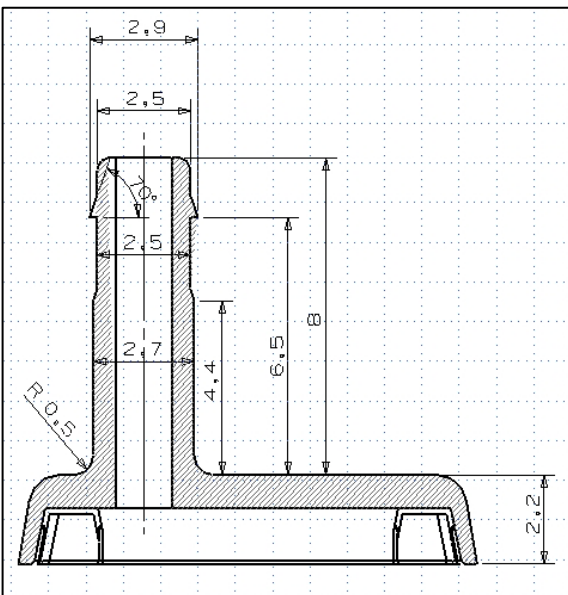

Figure 11.5 Mechanical drawing: Section A in Figure 11.4 of tube connection (type A)

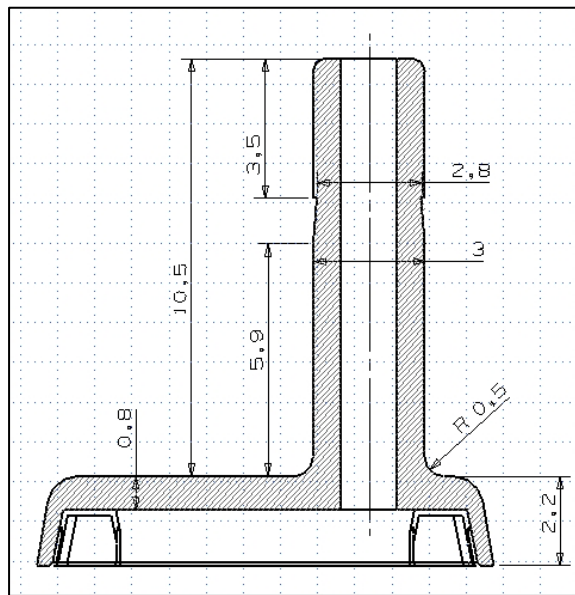
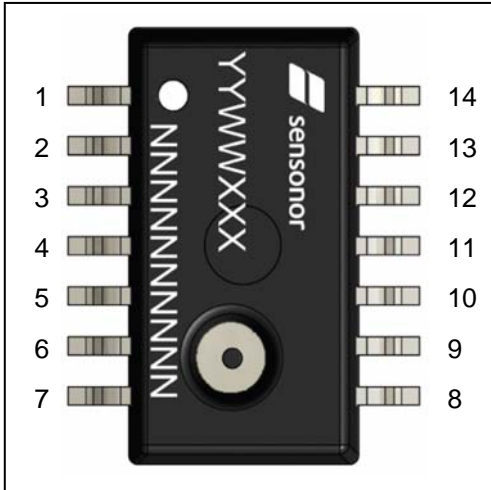

Figure 11.6 Mechanical drawing: Section A in Figure 11.4 of tube connection (type B)

11.3 Pin Configuration

Table 11.1 Pin configuration description



PIN	NAME	FUNCTION	NOTE
1	WAKE UP	Wake up output signal	
2	RESET	Reset output signal	
3	TEST/GND	Test in fabrication	Ground in application
4	VSS	Ground	
5	NC	Not connected	Ground in application
6	DIG IN/GND	Digital input in fabrication	Ground in application
7	VSS	Ground	
8	VSS	Ground	
9	VDD	Supply voltage	
10	VPP	Programmation voltage	Leave open
11	SDI	Serial data input	
12	SCLK	Serial clock input	
13	SDO	Serial data output	
14	NCS	Negative chip select input	

Figure 11.7 Pin configuration, top view

11.4 Marking

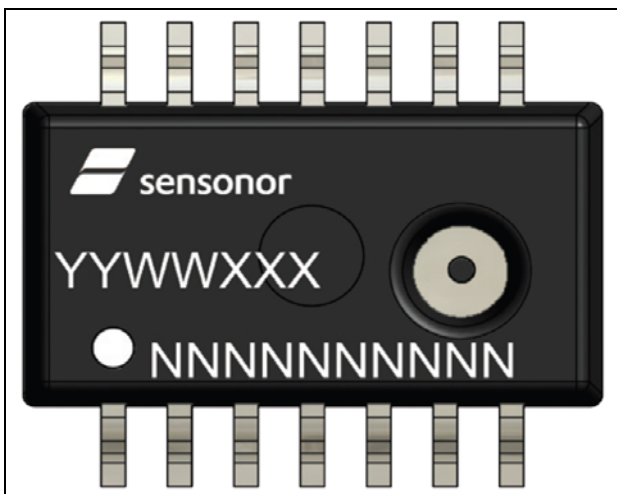

Figure 11.8 Marking of the SP100 series

The variables in Figure 11.8 have the following meaning:

YYWWXXX : Lot number
 NNNNNNNNNN: Product name
 O: Pin 1 marking

X-ON Electronics

Largest Supplier of Electrical and Electronic Components

Click to view similar products for [sensolute](#) manufacturer:

Other Similar products are found below :

[MVS0608.02](#)