

SP300 Series Compensated Pressure Sensors With Embedded Microcontroller

The SP300 Pressure Sensor series represents Sensoror Technologies' most advanced pressure sensors. Based on already known technology, the SP300 adds a level of integration by including microcontroller and LF-input stages to meet market demands for flexible, customer specific behavior and solutions, and also resulting in over-all system cost reductions. The SP300 sensor is a micro system consisting of a micromachined sensor die and flexible ASIC, packaged in a low cost, plastic molded package (SOIC).

SP300 series has excellent media compatibility due to a patented bulk micromachined triple stack sensor die design, utilizing buried piezoresistive elements and backside media access to pressure diaphragm. With this design the internal connectors and piezoresistive elements of the pressure bridge are isolated from the measurement media. The isolation is of great advantage in terms of sensor stability and reliability over a very long lifetime.

The SP300 pressure sensor design has been proven in harsh environment applications during a period of more than 10 years, making these sensors ideal choices for demanding applications where reliable and accurate pressure measurements are required.

SP300-1
SP300-1T
SP300-2
SP300-2T

Edition 2009-07-02

Published by

Sensoror Technologies AS

P.O. Box 196

N-3192 Horten

Norway

© Sensoror Technologies AS 2009.

All Rights Reserved.

Information furnished by Sensoror Technologies is believed to be accurate and reliable. However, no responsibility is assumed by Sensoror Technologies for its use, nor for any infringements of patents or other rights of third parties that may result from its use. Sensoror Technologies reserves the right to make changes without further notice to any products herein. Sensoror Technologies makes no warranty, representation or guarantee regarding the suitability of its products for any particular purpose, nor does Sensoror Technologies assume any liability arising out of the application or use of any product or circuit, and specifically disclaims any and all liability, including without limitation consequential or incidental damages. No license is granted by implication or otherwise under any patent or patent rights of Sensoror Technologies. Trademarks and registered trademarks are the property of their respective owners. Sensoror Technologies products are not intended for any application in which the failure of the Sensoror Technologies product could create a situation where personal injury or death may occur. Should Buyer purchase or use Sensoror Technologies products for any such unintended or unauthorized application, Buyer shall indemnify and hold Sensoror Technologies and its officers, employees, subsidiaries, affiliates, and distributors harmless against all claims, costs, damages, and expenses, and reasonable legal fees arising out of, directly or indirectly, any claim of personal injury or death associated with such unintended or unauthorized use, even if such claim alleges that Sensoror Technologies was negligent regarding the design or manufacture of the part.



Table of Contents

- 1 Product Description - 4 -
 - 1.1 Features - 4 -
 - 1.2 Overview - 4 -
- 2 Product Characteristics - 5 -
 - 2.1 Measurement performance - 5 -
 - 2.2 Current consumption - 6 -
 - 2.3 T_{max}..... - 6 -
 - 2.4 V_{min} - 6 -
 - 2.5 Clock sources - 7 -
 - 2.6 LF input..... - 7 -
 - 2.7 Power-on reset - 8 -
 - 2.8 Digital I/O..... - 8 -
- 3 Recommended Operating Conditions - 8 -
- 4 Absolute Maximum Ratings - 8 -
- 5 Electrical and peripheral units - 9 -
 - 5.1 System description - 9 -
 - 5.2 RISC controller - 10 -
- 6 Physical Dimensions and Marking - 11 -
 - 6.1 Physical Dimensions - 11 -
 - 6.2 Tube Connection (option) - 12 -
 - 6.3 Pin Configuration - 13 -
 - 6.4 Marking..... - 13 -



1 Product Description

1.1 Features

- RISC microcontroller
- High flexibility
- Code protection
- ROM library functions
- 5 general purpose I/O pins
- On-chip RC oscillator
- Absolute pressure sensor
- Calibrated and compensated
- Temperature and supply voltage measurements output
- Sensor self diagnosis
- Unique electronic sensor ID
- 2 channel LF receiver for wireless applications (125 kHz)
- High reliability and accuracy over lifetime
- High media compatibility
- Wide temperature operating range
- Low standby current (0.3 μ A)
- Robust miniature surface mount package
- Tube connection option (for T version sensors)

1.2 Overview

The SP300 Pressure Sensor series is the most advanced pressure sensors from Sensoror Technologies. The SP300 offers a high level of integration by including a microcontroller, a set of predefined ROM library functions, signal conditioning and LF-input stage (enabling wireless wakeup and command and data reception) to meet market demands for flexible, customer specific solutions and overall system cost reduction.

The SP300 Pressure Sensor series have excellent media compatibility due to the patented bulk micro machined triple stack sensor design. It utilizes buried piezoresistive elements and backside media access. With this design, the piezo resistors will avoid contact with the measurement media.

The SP300-1(T) and SP300-2(T) measures absolute pressures up to 200kPa. In addition to pressure the sensor provides temperature and supply voltage measurements. By integrating these functions with an ASIC in one package, Sensoror Technologies has developed an attractive product for a broad range of advanced pressure sensor applications.

The accuracy, stability and reliability of the SP300 design have been proven in applications during a period of more than 10 years. The sensors are ideal choices for demanding measurements, also in harsh environment, or in applications where advanced solutions are needed for implementing reliable pressure measurements. The SP300 is packaged in a proven 14 pin, SOIC package that efficiently can be handled by automatic production lines. Some of the SP300 models features a tube connection to ease pressure connection.



2 Product Characteristics

2.1 Measurement performance

2.1.1 Pressure measurement

The presented performance reflects the use of 11-bit measurement of pressure and 10-bit measurement of temperature.

Parameter	Specification			Ambient conditions	
	Model	Unit	Typ	Temperature [°C]	Pressure [kPa]
Resolution	SP300-1 SP300-1T	kPa/ lsb	0.25	-40 to 125	0 to 100
	SP300-2 SP300-2T	kPa/ lsb	0.5	-40 to 125	0 to 200
Accuracy	SP300-1 SP300-1T	kPa	±1.9	0 to 50	0 to 100
		kPa	±2.3	50 to 70	0 to 100
		kPa	±4.5	-40 to 125	0 to 100
	SP300-2 SP300-2T	kPa	±2.0	0 to 50	0 to 200
		kPa	±2.4	50 to 70	0 to 200
		kPa	±4.6	-40 to 125	0 to 200

2.1.2 Temperature measurement

The presented performance reflects the use of 10-bit measurement of temperature.

Parameter	Specification			Ambient conditions
	Model	Unit	Typ	Temperature [°C]
Accuracy	All	°C	±1.8	-20 to 70
		°C	±3.0	-40 to 90
		°C	-1.8 / 4.2	90 to 125

2.1.3 Supply voltage measurement

The presented performance reflects the use of 9-bit measurement of supply voltage.

Parameter	Specification			Ambient conditions	
	Model	Unit	Typ	Temperature [°C]	VDD [V]
Accuracy	All	mV	±60	-40 to 125	V _{THR} to 3.6 ¹⁾

1) See section 2.7 for V_{THR} specification.



2.2 Current consumption

Parameter	Specification				Ambient Conditions		Comments
	Min	Typ	Max	Unit	Temp [°C]	Vdd [V]	
Power down current		0.4	0.6	µA	25	3.0	
Power down current		13	20	µA	125	3.0	
IDLE current		30	50	µA	25	3.0	
IDLE current		50	75	µA	125	3.0	
RUN current		0.53	0.8	mA	25	3.0	
RUN current		0.65	1.0	mA	125	3.0	
Pressure measurement		4	12	µAs	-40 to 125	2.1 to 3.6	11 bit A/D conversion, excl. temperature measurement
Temperature measurement		0.9	2.5	µAs	-40 to 125	2.1 to 3.6	10 bit A/D conversion
Supply voltage measurement		0.3	2.5	µAs	-40 to 125	2.1 to 3.6	9 bit A/D conversion
Peak current		1.6	2.5	mA	25	3.0	Pressure measurement and 1 LF channel on, duration is 1280µs for 11 bit measurement for the peak current only.
1 channel LF current		2.6	4.6	µA	25	3.0	
1 channel LF current		3.0	6.7	µA	125	3.0	
2 channel LF current		4.5	5.5	µA	25	3.0	2 nd LF channel is optional
2 channel LF current		6.5	11	µA	125	3.0	2 nd LF channel is optional
Thermal shutdown current		18	25	µA	125	3.0	
Thermal shutdown current		30	50	µA	150	3.0	

2.3 T_{max}

ϑ_{SHTD} represents the temperature at which the Thermal Shut-down function can be enabled and ϑ_{REL} represents the temperature at which the Master Reset state is released. The ϑ_{SHTD} is always higher than ϑ_{REL} .

Parameter	Specification				Ambient Conditions		Comments
	Min	Typ	Max	Unit	Temp [°C]	Vdd [V]	
ϑ_{SHTD}	102		123	°C	-40 to 175	2.1 to 3.6	Thermal shutdown enable
ϑ_{REL}	100		121	°C	-40 to 175	2.1 to 3.6	Master Reset release

2.4 V_{min}

The voltage at which the V_{min}-circuit will return a low battery voltage status is specified in chapter 2.7.

Parameter	Specification				Ambient Conditions		Comments
	Min	Typ	Max	Unit	Temp [°C]	Vdd [V]	
V _{min}	2.0	2.1	2.2	V	-40 to 125	V _{THR} to 3.6	See section 2.7 for V _{THR} specification



2.5 Clock sources

2.5.1 System clock (MCLK)

Parameter	Specification				Ambient Conditions		Comments
	Min	Typ	Max	Unit	Temp [°C]	Vdd [V]	
MCLK frequency	1.8	2.0	2.2	MHz	-40 to 125	2.1 to 3.6	

2.5.2 Low Power (LP) oscillator

Parameter	Specification				Ambient Conditions		Comments
	Min	Typ	Max	Unit	Temp [°C]	Vdd [V]	
T _{it}	0.5, 1.0, 2.0 or 4.0			s	-40 to 125	2.1 to 3.6	Interval timer main tick
del _{2t}	25, 50, 75 or 100			ms	-40 to 125	2.1 to 3.6	Delay to extra tick
LP oscillator accuracy	-20		20	%	-40 to 125	2.1 to 3.6	

2.5.3 External clock

Parameter	Specification				Ambient Conditions		Comments
	Min	Typ	Max	Unit	Temp [°C]	Vdd [V]	
External clock			3.5	MHz	-40 to 125	2.1 to 3.6	

2.6 LF input

Table 2.1 LF telegram

Parameter	Specification				Ambient Conditions		Comments
	Min	Typ	Max	Unit	Temp [°C]	Vdd [V]	
Modulation		ASK			-40 to 125	2.1 to 3.6	
Carrier frequency	121.25	125	128.75	kHz	-40 to 125	2.1 to 3.6	
Preamble period	4			ms	-40 to 125	2.1 to 3.6	
Data rate	3.84	3.9	3.96	kHz	-40 to 125	2.1 to 3.6	
Settling time			2	ms	-40 to 125	2.1 to 3.6	Time from LF interface is turned on by RISC to the LF interface is active
Detection threshold			5	mVp-p	-40 to 125	2.1 to 3.6	
Input capacitance		10	12	pF	-40 to 125	2.1 to 3.6	
Input resistance	500			kΩ	-40 to 125	2.1 to 3.6	
Other	The input signals from the enabled LF channels are rectified and real time summed						

Table 2.2 LF Carrier Detection

Parameter	Specification				Ambient Conditions		Comments
	Min	Typ	Max	Unit	Temp [°C]	Vdd [V]	
Carrier frequency	121.25	125	128.75	kHz	-40 to 125	2.1 to 3.6	
Maximum sensitivity not to detect, 2 amplifiers enabled	4			mVp-p	0 to 90	2.1 to 3.6	
	3.5			mVp-p	90 to 125	2.1 to 3.6	
	3.5			mVp-p	-40 to 0	2.1 to 3.0	
	2.9			mVp-p	-40 to 0	3.0 to 3.6	
Minimum sensitivity to detect, 2 amplifiers enabled	10			mVp-p	0 to 90	2.1 to 3.6	
	12.2			mVp-p	90 to 125	2.1 to 3.6	
	12.2			mVp-p	-40 to 0	2.1 to 3.6	
Maximum sensitivity not to detect, 3 amplifiers enabled		0.8		mVp-p	-40	3.6	Guaranteed by ASIC characterization
	0.25			mVp-p	-40	2.1 to 3.0	
	0.25			mVp-p	0 to 125	2.1 to 3.6	
Minimum sensitivity to detect, 3 amplifiers enabled			2.5	mVp-p	-40 to 125	2.1 to 3.6	Guaranteed by ASIC characterization



2.7 Power-on reset

Parameter	Specification				Comments
	Min	Typ	Max	Unit	
Power-on reset level, V_{THR}	1.8	1.85	1.9	V	

2.8 Digital I/O

Parameter	Specification				Comments
	Min	Typ	Max	Unit	
Digital output high	$V_{DD}-0.3$			V	At 1 mA load current
Digital output low			0.3	V	At 1 mA load current
Digital input high	$0.8 \cdot V_{DD}$			V	
Digital input low			$0.2 \cdot V_{DD}$	V	
Input current			± 1	μA	

3 Recommended Operating Conditions

Parameter	Specification					Comments
	Model	Min	Typ	Max	Unit	
Input pressure	SP300-1 SP300-1T	0		100	kPa	
	SP300-2 SP300-2T	0		200	kPa	
Supply voltage		V_{THR}		3.6	V	Unless otherwise specified
Ambient temperature		-40		125	$^{\circ}C$	

4 Absolute Maximum Ratings

Parameter	Specification				Comments
	Min	Typ	Max	Unit	
Ambient temperature, operating	-40		150	$^{\circ}C$	Max 24 hrs accumulated over life time
Ambient temperature, storage	-40		150	$^{\circ}C$	Max 1000 hours
Transient temperature			175	$^{\circ}C$	Max 3 min. Will withstand standard reflow soldering process (JEDEC JESD22-B102-C)
Supply Voltage	-0.3		4.0	V	
Input voltage	-0.3		$V_{DD}+0.3$	V	
Input current, any pin (DC)	-10		10	mA	
Input current, any pin (transient)	-100		100	mA	
Input current, LF pins	-1		1	mA	
Maximum input pressure			600	kPa	
ESD	± 2.0			kV	Human body model AEC-Q100
	± 500			V	Charge device model AEC-Q100
Latch Up	100			mA	AEC-Q100

Stress beyond the absolute maximum ratings may cause permanent damage to the device. Exposure to absolute maximum rating conditions for extended periods may affect device reliability. Maximum ratings are absolute ratings; exceeding only one of these values may cause irreversible damage to the device.



5 Electrical and peripheral units

5.1 System description

The SP300 sensor is a micro system consisting of two dies packaged in a low cost, plastic molded package as shown in Figure 6.1. The die shown to the left is a micro machined chip containing a pressure. The die to the right is the ASIC containing the remaining part of the micro system. A block diagram is shown in Figure 5.2.

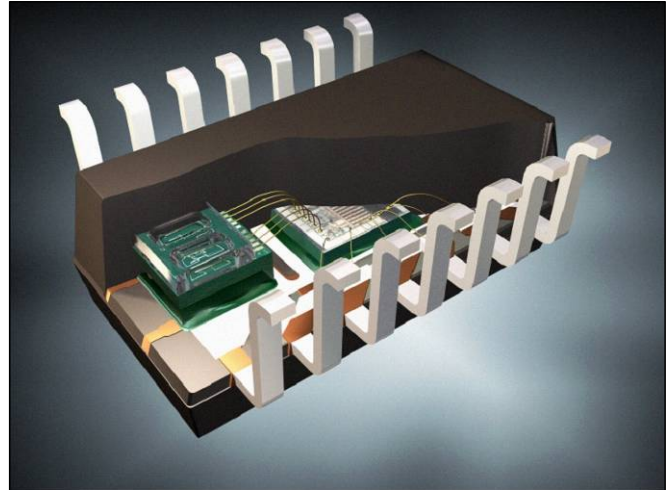

Figure 5.1 View of sensor internals

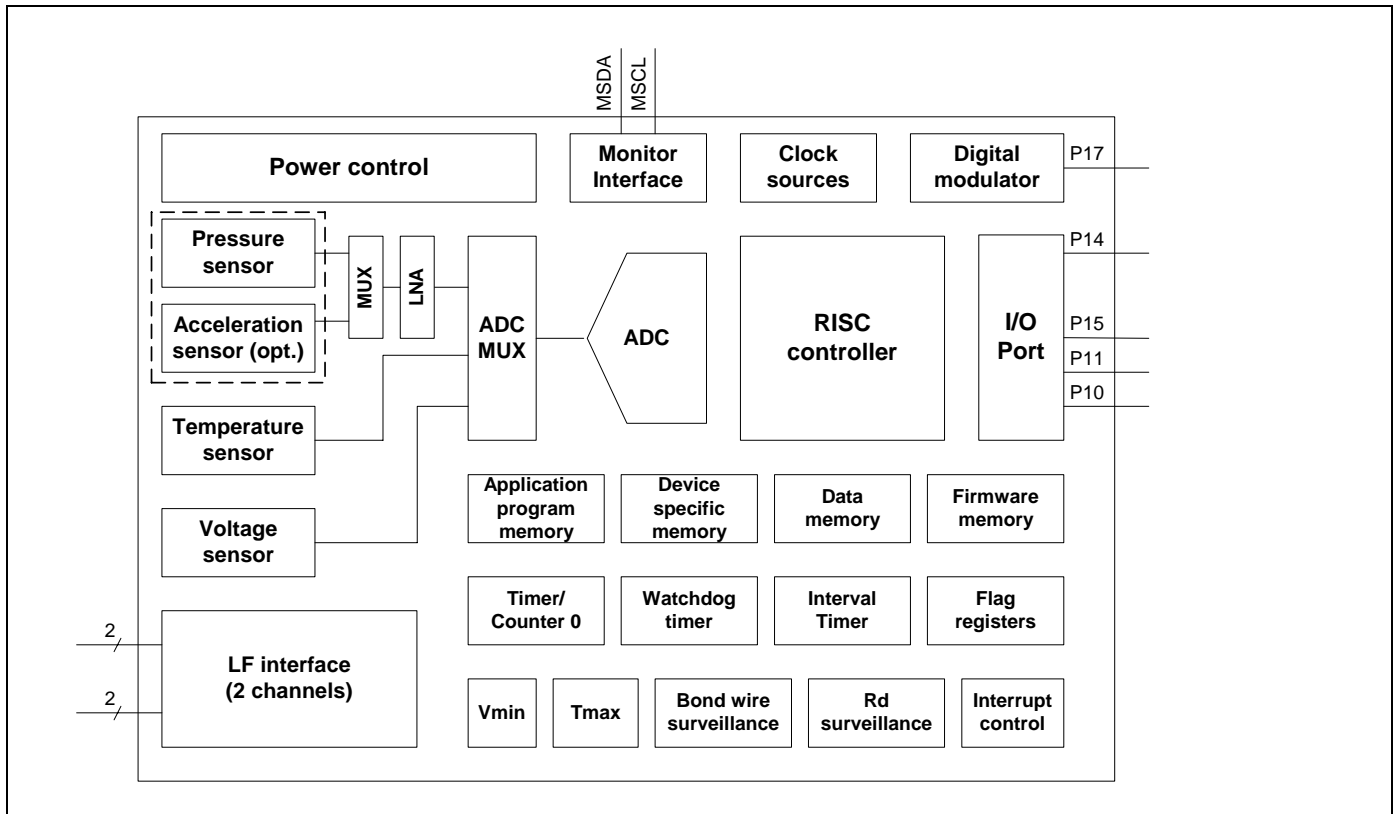

Figure 5.2 SP300 series block diagram



5.2 RISC controller

The SP300 employs a low-power RISC (Reduced Instruction Set Computing) controller to control device operation according to an application program. The RISC is clocked from an on-chip RC oscillator, while the peripheral unit Timer/Counter 0 may be clocked from an external source, for example the reference clock of a PLL chip in case a higher precision or synchronous timing is desired.

The RISC features an 8 bit Harvard architecture with 16 bit instructions. Due to a two-stage pipeline concept the instructions execute in a single instruction cycle, featuring fast execution time and low-power consumption. The RISC block diagram is shown in Figure 6.3.

Byte-wise read access for the Application Program Memory is provided, whereas the firmware is not visible to the application program due to the implemented shadow mechanism. A software interrupt (SYS) allows the execution of library functions in ROM. The SYS mechanism handles the transition to the “shadowed” ROM.

The RISC features 128 byte of internal Data Memory. The Data Memory is also used as 16-bit program stack during subroutine calls and interrupts. Although no specific instructions are provided to manipulate this stack (e.g. Push/Pop), the RISC features auto-increment and auto-decrement addressing modes to enable data stack handling by the application program.

Peripherals of the RISC (timer, I/O, etc) are accessible via a Special Function Register File (SFR) that is mapped into the Data Address Space. The RISC allows byte-oriented as well as bit wise access to both Data Memory and SFR's. Eight general purpose registers (8 bit) are provided. Four of them may be used in the context of indirect addressing. Two of these registers provide additional post-increment and pre-decrement addressing modes in order to support e.g. a software data stack.

The ALU (Arithmetic Logic Unit) supports instructions for arithmetic, logical and Boolean data manipulation. The single priority level Interrupt Control system features an additional wakeup function from IDLE mode, which provides the application program with a convenient means to synchronize with the peripherals. A number of special loop control and bit shift instructions are available to optimize code speed and size.

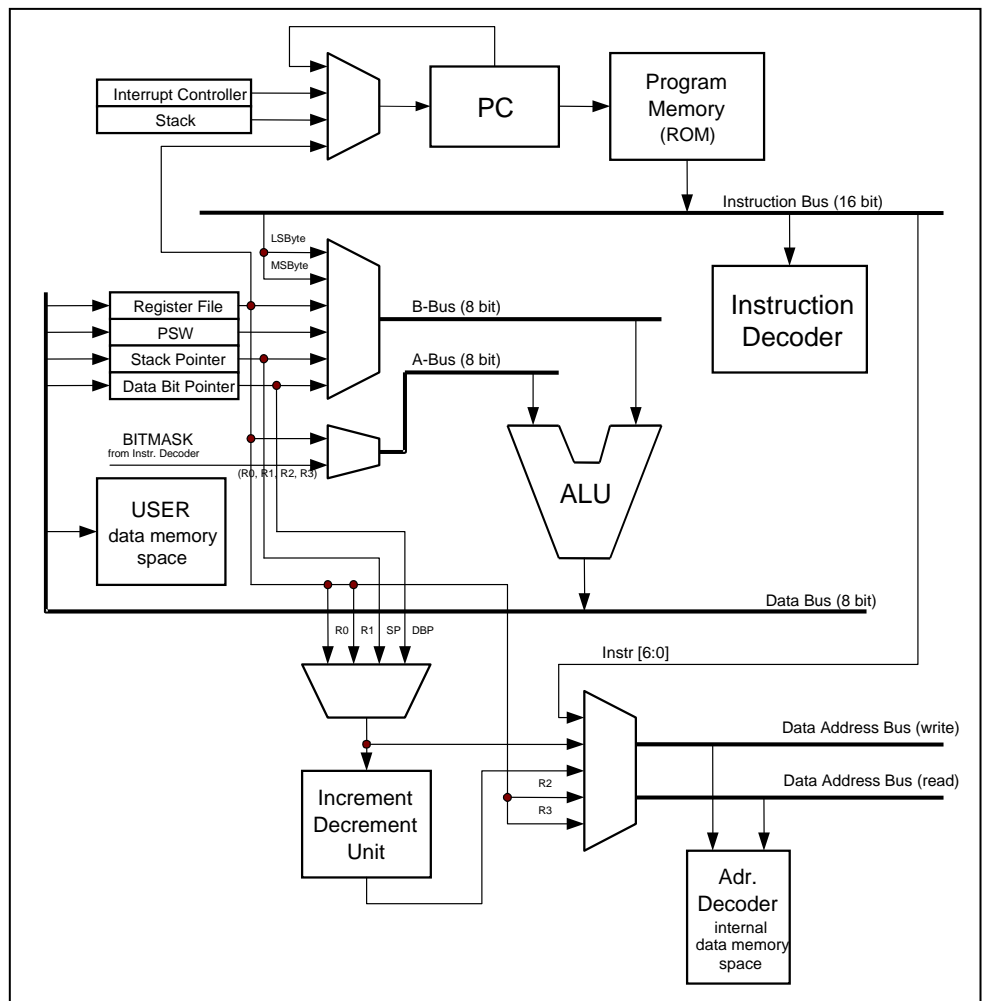

Figure 5.3 SP300 RISC controller block diagram



6 Physical Dimensions and Marking

6.1 Physical Dimensions

The sensor package is a proven 14 pin, SOIC package that can be handled by automatic production lines.

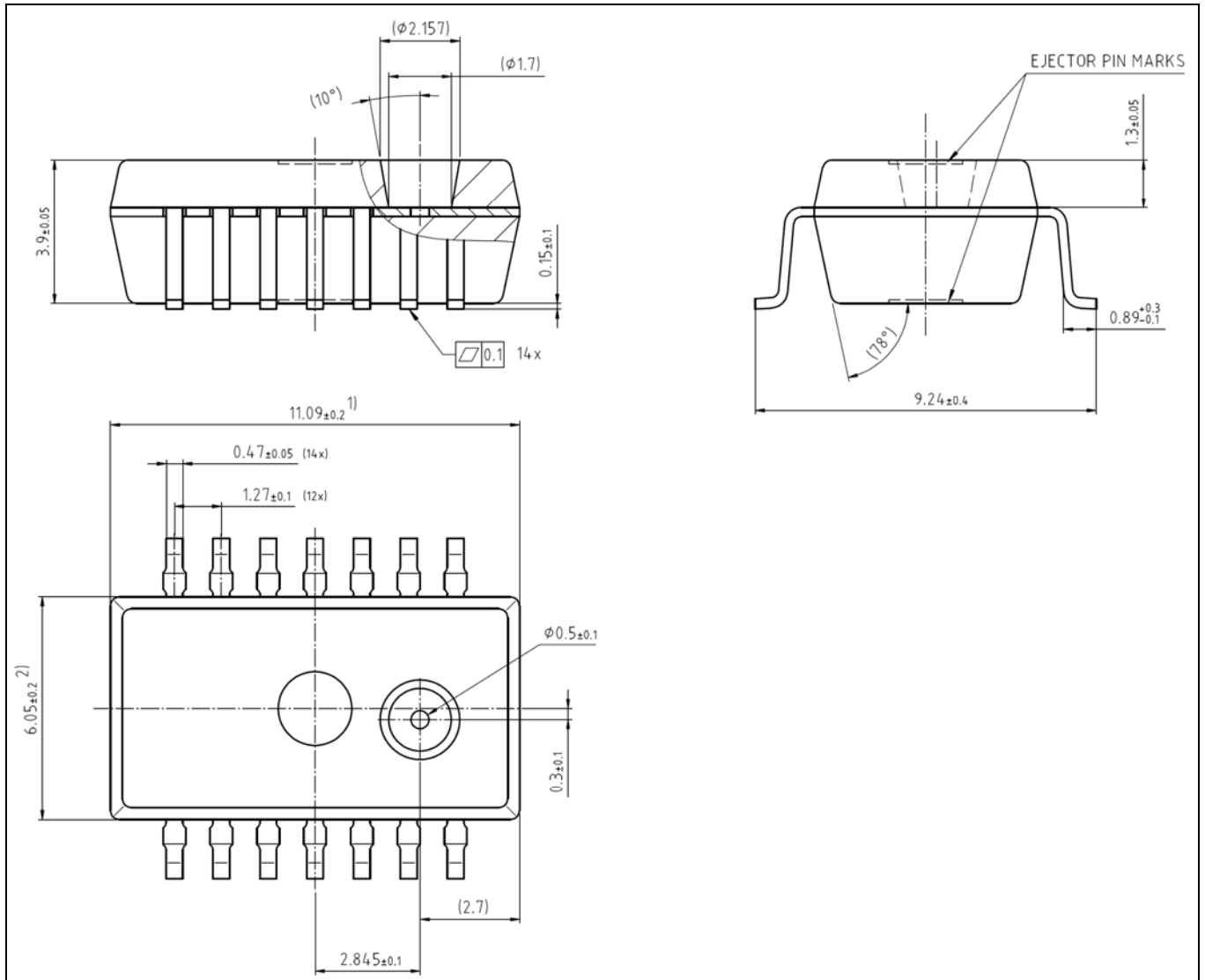

Figure 6.1 Physical dimensions drawing

- Dimension does not include mold flash, protrusions or gate burrs. Mold flash, protrusions and gate burrs do not exceed 0.15mm (0.006 inch) per side.
- Dimension does not include inter-lead flash or protrusions. Inter-lead flash and protrusions do not exceed 0.25mm (0.010 inch) per side.



6.2 Tube Connection (option)

The SP300 models with 'T' in the model name features two different tube connection options to ease pressure connection.

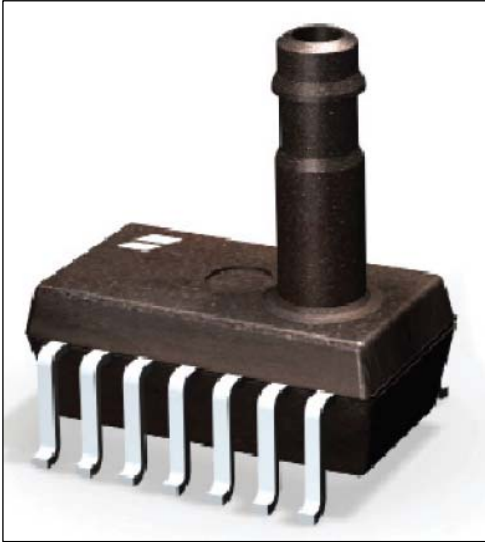

Figure 6.3 Illustration of the SP300 series with tube connection (type A)

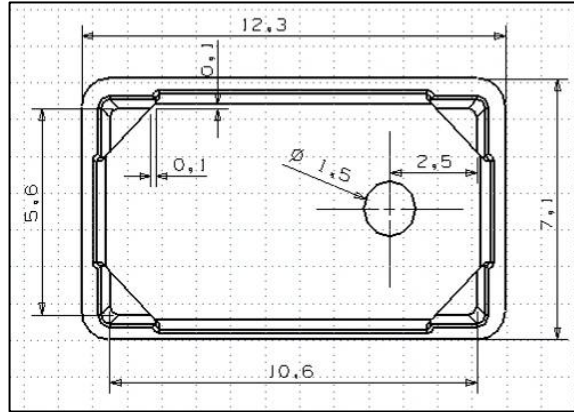

Figure 6.2 Mechanical drawing: Underside of tube connection (type A and type B)

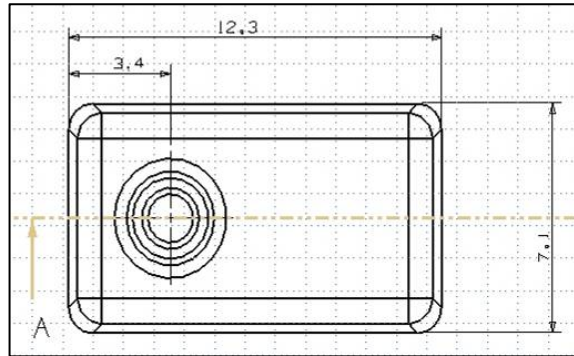

Figure 6.4 Mechanical drawing: Upside of tube connection (type A and B)

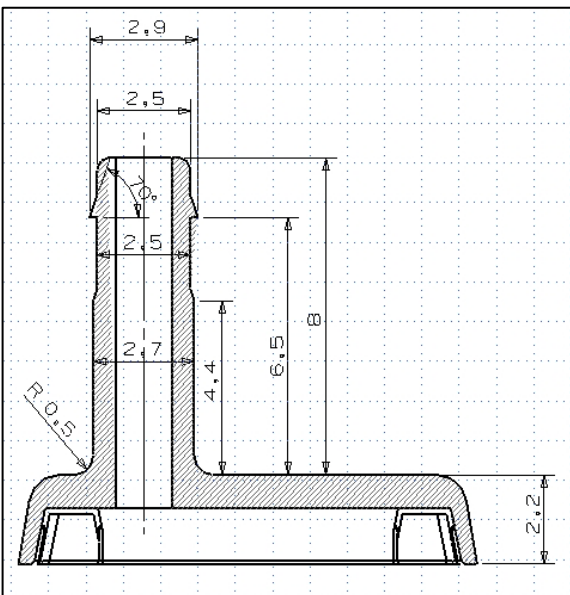

Figure 6.5 Mechanical drawing: Section A in Figure 6.4 of tube connection (type A)

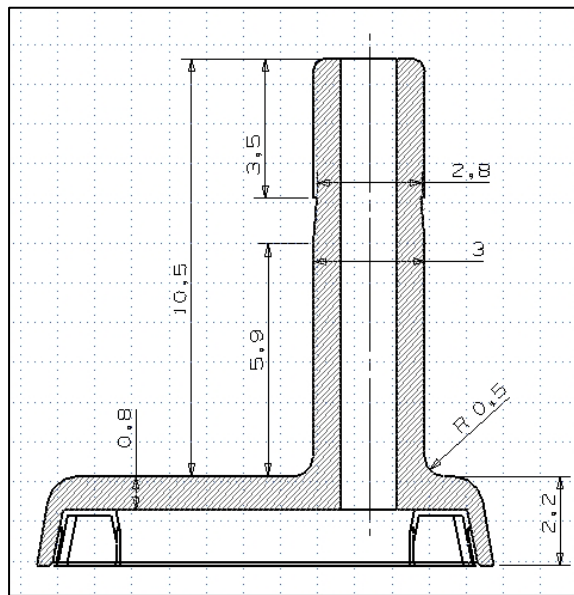

Figure 6.6 Mechanical drawing: Section A in Figure 6.4 of tube connection (type B)



6.3 Pin Configuration

Table 6.1 Pin Description

Pin	Name	Function
1	IN4	LF receiver channel 2, negative input
2	P10	General purpose I/O with external wakeup, internal pull-up/pull-down
3	P11	General purpose I/O with external wakeup, internal pull-up/pull-down
4	MSDA	Monitor Serial Data I/O, internal pull-up
5	MSCL	Monitor Serial Clock input
6	VDD	Supply pad VDD (battery, positive terminal)
7	VSS	Common ground (battery, negative terminal)
8	VSS	Common ground (battery, negative terminal)
9	P17	General purpose I/O (or digital modulator output)
10	P15	General purpose I/O or external clock
11	P14	General purpose I/O (or digital modulator output)
12	IN1	LF receiver channel 1, positive input
13	IN2	LF receiver channel 1, negative input
14	IN3	LF receiver channel 2, positive input

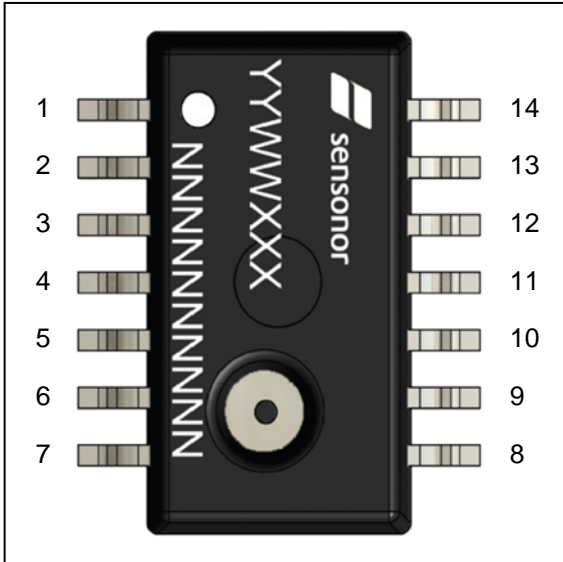

Figure 6.7 Pin configuration, top view

6.4 Marking

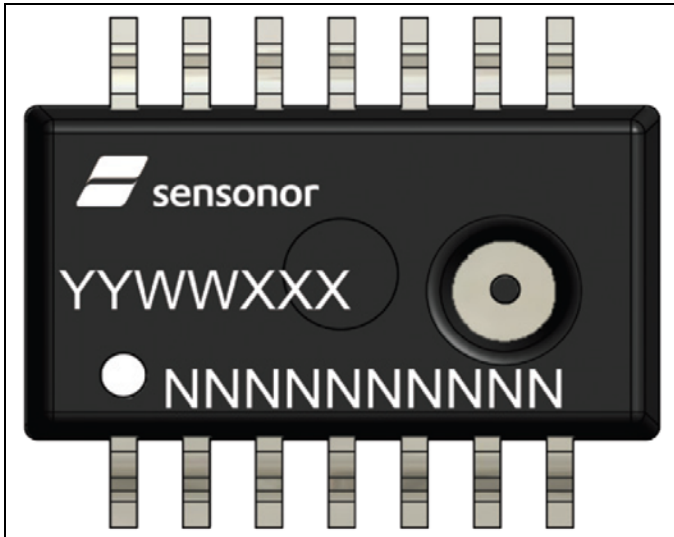

Figure 6.8 Marking of the SP300 series

The variables in Figure 6.8 have the following meaning:

- YYWWXXX : Lot number
- NNNNNNNNNN: Product name
- O: Pin 1 Marking

X-ON Electronics

Largest Supplier of Electrical and Electronic Components

Click to view similar products for [sensolute](#) manufacturer:

Other Similar products are found below :

[MVS0608.02](#)