



## General Description

The SQ6211B is a non-isolated buck, highly-integrated, low start-up current, average current mode, one cycle control PFC (Power Factor Correction) and a 45kHz fixed switching frequency PWM LEDs driver controller. These functions enable the LEDs driver to easily meet the accuracy average LEDs current and high PF (Power Factor) requirements.

The COMP pin controls the duty by connected an RC compensation network to ground and forming the closed loop feedback control. The LEDs current dimming can be easily controlled via the DIM pin.

To protect the external power MOSFET from being damaged by supply over voltage, the SQ6211B GATE pin voltage is clamped to about 17V. The integrated functions include the output LEDs short circuit protection, over current protection, open loop protection and internal over temperature protection. The SQ6211B is available in a small 6-pin SOT23 package.

## Pin Configurations

(Top View)

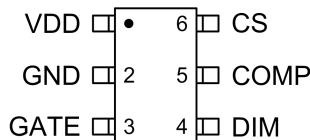

SOT23-6

## Marking Information

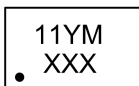

11 : Product Number  
YM : Date Code  
XXX : Serial Number

## Features

- Low cost and efficient buck converter solution
- Universal input voltage range with off-line topology
- High PF by one cycle control (PF > 0.9 typical)
- High accuracy constant current ( $\pm 3\%$ )
- High efficiency ( $\eta > 0.9$  typical)
- Average current mode at 45kHz fixed frequency
- 300mA driving capability for GATE pin
- GATE pin output voltage clamp to 17V
- Support linear dimming control via the DIM pin
- Output LEDs Short Circuit Protection (SCP)
- Output LEDs Over Current Protection (OCP)
- Output LEDs Open Loop Protection (OLP)
- Over Voltage Protection (OVP) on the VDD pin
- Built-in Over Temperature Protection (OTP)
- Incompatible electronic and inductance ballasts
- Available in a small SOT23-6 package
- RoHS compliant and halogen free

## Applications

- E26/E27 LEDs bulbs, T5/T8 LEDs tubes
- Others off-line LEDs lighting applications

## Order Information

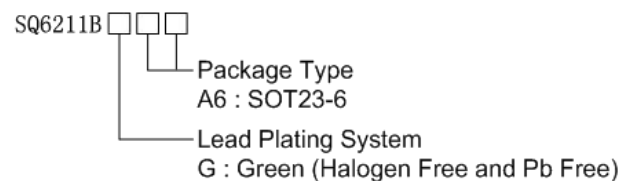

## Simplified Application Circuit

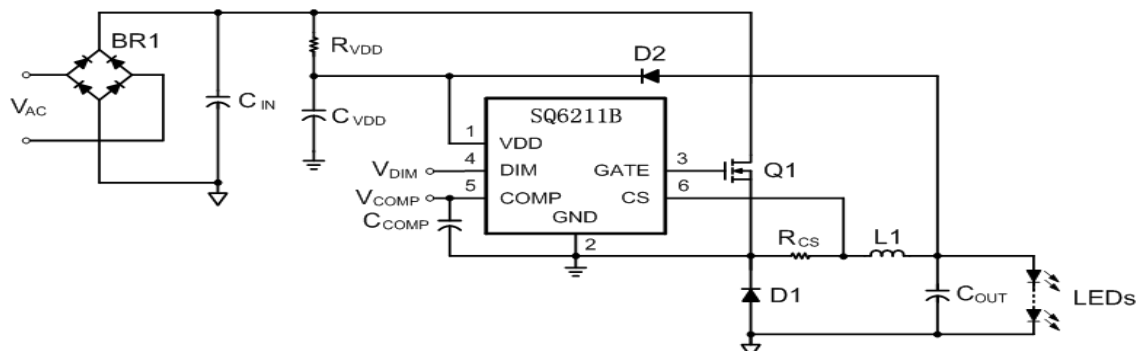



## Functional Pin Description

Pin Name	Pin No.	Pin Function
VDD	1	Supply voltage Input of the chip. For good bypass, a ceramic capacitor near the VDD pin is required.
GND	2	Ground of the chip.
GATE	3	Gate driver output for external power MOSFET switch.
DIM	4	Analog dimming control input. The effective dimming range is between 0.6V to 3.0V.
COMP	5	PWM loop compensation node.
CS	6	LEDs current sensing input pin. The typical sensing threshold voltage is 200mV between the CS and GND pins.

## Function Block Diagram

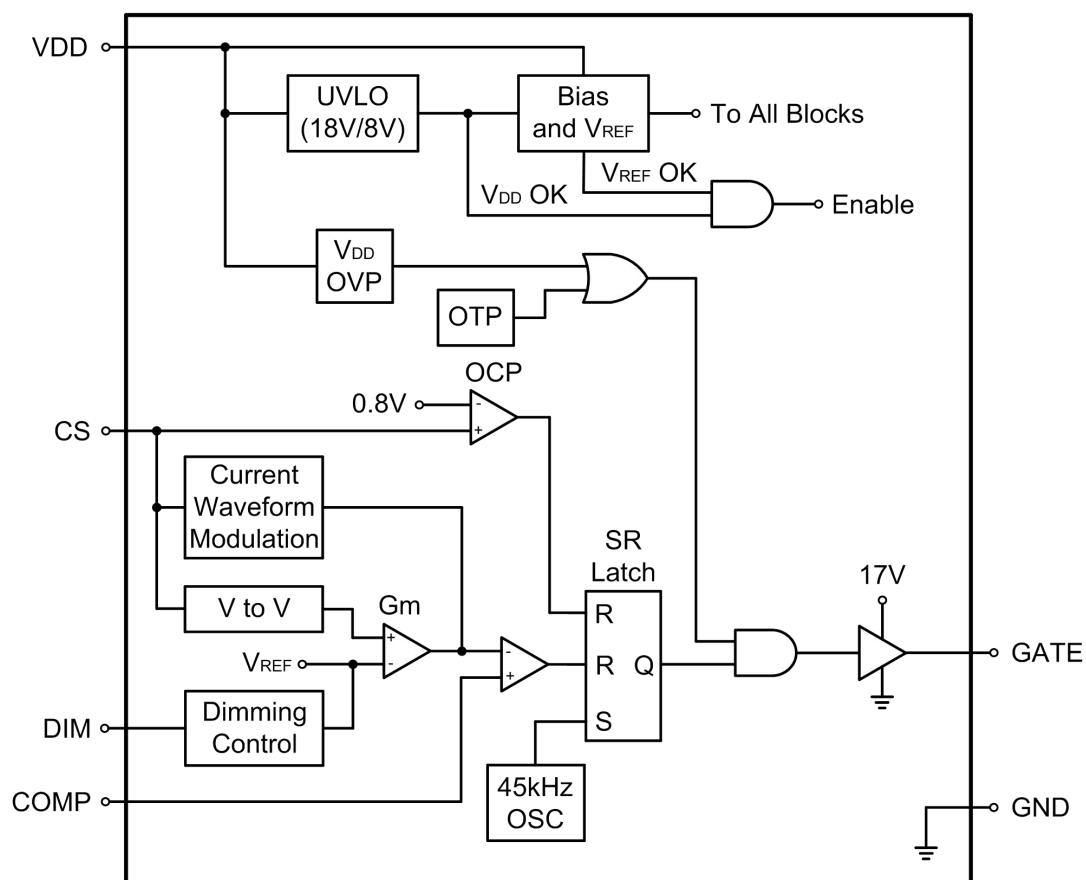



## Absolute Maximum Ratings (Note 1)

• VDD input pin DC supply voltage, $V_{DD}$ -----	-0.3V to 30V
• DIM, COMP, CS input pin voltage, $V_{DIM}$ , $V_{COMP}$ , $V_{CS}$ -----	-0.3V to 7V
• GATE output pin voltage, $V_G$ -----	30V
• Power dissipation, $P_D @ T_A = 25^\circ\text{C}$ (Note 2)	
SOT23-6 -----	0.3W
• Package thermal resistance (Note 3)	
SOT23-6, $\theta_{JA}$ -----	333°C/W
SOT23-6, $\theta_{JC}$ -----	106.6°C/W
• Junction temperature, $T_J$ -----	150°C
• Lead temperature (Soldering, 5 sec.) -----	260°C
• Storage temperature range -----	-65°C to 150°C
• ESD susceptibility (Note 4)	
HBM (Human Body Model) -----	2kV
MM (Machine Model) -----	200V

## Recommended Operating Conditions (Note 5)

• DC input supply voltage range, $V_{DD}$ -----	12V to 25V
• Junction temperature range, $T_J$ -----	-40°C to 150°C
• Ambient temperature range, $T_A$ -----	-20°C to 85°C

Notes :

- (1). Stresses listed as the above “Absolute Maximum Ratings” may cause permanent damage to the device. These are for stress ratings. Functional operation of the device at these or any other conditions beyond those indicated in the operational sections of the specifications is not implied. Exposure to absolute maximum ratings conditions for extended periods may remain possibility to affect device reliability.
- (2). The maximum allowable power dissipation is a function of the maximum junction temperature  $T_{J(MAX)}$ , the junction-to-ambient thermal resistance  $\theta_{JA}$ , and the ambient temperature  $T_A$ .
- (3). Thermal resistance is specified with the component mounted on a low effective thermal conductivity test board in free air at  $T_A = 25^\circ\text{C}$ .
- (4). Devices are ESD sensitive. Handling precaution is recommended.
- (5). The device function is not guaranteed outside of the recommended operating conditions.



## Electrical Characteristics

( $V_{DD} = 18V$ ,  $T_A = 25^\circ C$ , unless otherwise noted)

Parameter	Symbol	Test Conditions	Min	Typ	Max	Unit
<b>DC Input</b>						
$V_{DD}$ input start-up voltage	$V_{DD\_ST}$		17	18	19	V
$V_{DD}$ minimum operation voltage after start-up	$V_{DD\_MIN}$		7	8	9	V
Start-up current	$I_{VDD\_ST}$	Before start-up, $V_{DD} = V_{DD\_ST} - 1V$	--	8	--	$\mu A$
Quiescent current at operation mode	$I_{VDD\_OP}$	After start-up, 1nF loading at GATE pin, $V_{COMP} = 2.5V$	--	1.5	2.5	mA
Quiescent current at protection mode	$I_{VDD\_PRO}$	1nF loading at GATE pin, Protection (OCP, OVP, SCP, OTP) tripped	--	1.2	1.8	mA
<b>Current Sensing</b>						
Current sensing voltage	$V_{CS}$		194	200	206	mV
Trans-conductance	$G_m$		--	120	--	$\mu S$
COMP pin sinking current (Note 6)	$I_{COMP\_SINK}$	$V_{CS} = -250mV$	--	32	--	$\mu A$
COMP pin sourcing current (Note 6)	$I_{COMP\_SOURCE}$	$V_{CS} = -150mV$	--	32	--	$\mu A$
Leading-edge blanking time	$t_{BK}$		--	410	--	ns
<b>Oscillator</b>						
Switching frequency	$f_{OSC}$		42	45	48	kHz
Maximum duty	$D_{MAX}$		80	90	--	%
Frequency jitter range	$\frac{\Delta f_{OSC}}{f_{OSC}}$		--	$\pm 6$	--	%
Frequency variation vs. temperature deviation	$\frac{\Delta f_{OSC\_T}}{f_{OSC\_T}}$	$T_A = -40^\circ C$ to $125^\circ C$	--	--	6	%
Frequency variation vs. $V_{DD}$ deviation	$\frac{\Delta f_{OSC\_V}}{f_{OSC\_V}}$	$V_{DD} = 12V$ to $25V$	--	--	1	%
<b>Linear Dimming</b>						
Linear dimming range	$V_{DIM\_LD}$		0.6	--	3.0	V
LEDs current turn on threshold voltage	$V_{DIM\_ON}$		3.0	--	--	V
LEDs current turn off threshold voltage	$V_{DIM\_OFF}$		--	--	0.3	V
Current source	$I_{DIM}$		270	300	330	$\mu A$
<b>GATE Pin Driving Output</b>						
GATE pin clamp voltage	$V_{CLAMP}$	$V_{DD} = 25V$	--	17	20	V
GATE pin output rise time	$t_R$	1nF loading at GATE pin	--	160	--	ns
GATE pin output fall time	$t_F$	1nF loading at GATE pin	--	80	--	ns



## Electrical Characteristics (Continue)

( $V_{DD} = 18V$ ,  $T_A = 25^\circ C$ , unless otherwise noted)

Parameter	Symbol	Test Conditions	Min	Typ	Max	Unit
<b>Protections</b>						
Over voltage protection threshold voltage on the VDD pin (Note 7)	$V_{DD\_OVP}$	OVP test	26	28	30	V
Over voltage protection de-bounce time	$t_{B\_OVP}$		--	40	--	$\mu s$
Over current protection threshold voltage on the CS pin (Note 8)	$V_{CS\_OCP}$	OCP test	--	0.8	--	V
Delay time to output	$t_{D\_OCP}$		--	100	--	ns
Open loop protection threshold voltage when the CS pin open	$V_{CS\_OLP}$	OLP test	--	5	--	V
Thermal shutdown threshold (Note 8, 9)	$T_{SD}$	OTP test	--	150	--	$^\circ C$
Thermal shutdown hysteresis (Note 8, 9)	$\Delta T_{SD}$		--	30	--	$^\circ C$
OTP de-bounce time	$t_{B\_OTP}$		--	80	--	$\mu s$

Notes :

- (6). Guaranteed by design, not subjected to production test.
- (7). OVP is auto recovery type (latch off type optional).
- (8). OCP, SCP and OTP are auto recovery type.
- (9). Guaranteed by design.

## Typical Application Circuit

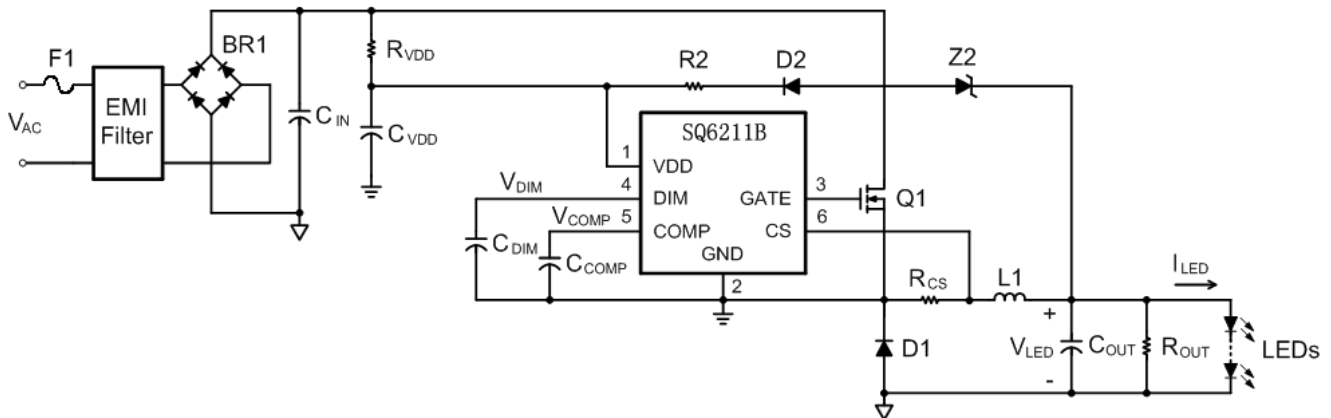

Figure 1. Typical Application Circuit

Table 1. Recommend Component Selection (For AC input voltage from 85V<sub>AC</sub> to 264V<sub>AC</sub>)

$V_{LED}$ (V)	$I_{LED}$ (mA)	F1 (A/V)	BR1	$C_{IN}$ ( $\mu F/V$ )	$C_{VDD}$ ( $\mu F/V$ )	$C_{OUT}$ ( $\mu F/V$ )	$C_{COMP}$ ( $\mu F$ )	$C_{DIM}$ (nF)
36	240	1/250	B6S	0.1/400	(10+6.8)/50	33/100	1	1
L1 (mH)	D1 (A/V)	D2 (A/V)	Q1 (A/V)	R2 ( $\Omega$ )	$R_{VDD}$ (k $\Omega$ )	$R_{CS}$ ( $\Omega$ )	$R_{OUT}$ (k $\Omega$ )	$V_{Z2}$ (V)
4.0	2/600	1/800	4/600	10	720	0.83 (Note 10)	200	24

Note :

- (10). Considering power consumption, use one 1.4 $\Omega$  resistor and one 2.0 $\Omega$  resistor with 1206 package in parallel for LED current sensing resistor ( $R_{CS}$ ).



## Application Information

### General Description

The SQ6211B is a PWM high-efficiency, low BOM cost LEDs driven control IC which provides an efficient solution for off-line high-brightness LEDs lamps from rectified line voltage ranging from 85V<sub>AC</sub> up to 264V<sub>AC</sub>. The SQ6211B drives an external high-side N-channel power MOSFET at a 45kHz fixed switching frequency. The YH6811 topology creates a constant current through the LEDs delivering a more uniform light output. The LEDs output current is programmed by an external resistor (R<sub>CS</sub>).

### Start-Up and Under Voltage Lockout

When the input power supply is first powered from the mains outlet, the start-up current begin to charge up the capacitor C<sub>VDD</sub> (Referring to the detail circuit in Figure 1). When the voltage on this start-up capacitor C<sub>VDD</sub> reaches the V<sub>DD\_ST</sub> level, the controller starts to control the external power MOSFET that transfers the power to turn on LEDs. At this time, the capacitor C<sub>VDD</sub> only supplies the controller before V<sub>DD</sub> collapses below V<sub>DD\_MIN</sub>. The biasing current from LEDs must establish before V<sub>DD</sub> goes below V<sub>DD\_MIN</sub> off, otherwise LEDs won't turn on in required time.

A hysteresis UVLO comparator is implemented in the YH6811, then the turn on and turn off threshold voltage level are fixed at 18V and 8V respectively. This hysteresis shown in Figure 2 ensures that the start-up capacitor will be adequate to supply the chip during start-up. For quickly start-up the LEDs driver, the start-up resistor should be matched with the start-up capacitor. Due to the low UVLO on voltage level, so the turn-on delay time will also never greater than the on-time of general PWM controller.

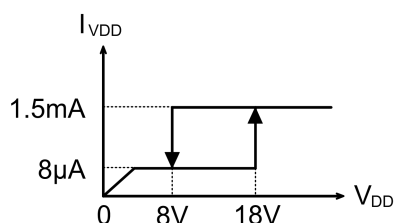

Figure 2. Start-Up Function

### Setting the LEDs Current

The average LEDs output current is set by an external sensing resistor connected from the CS pin to ground. The value of the current sensing resistor is calculated based on the desired average LEDs

current, the current sensing threshold voltage, and the inductor ripple current. The current detection threshold voltage is set at 0.2V (typical). The relationship between LEDs output current, I<sub>LED</sub>, and R<sub>CS</sub> is shown below :

$$I_{LED} \cong \frac{0.2V}{R_{CS}}$$

### Oscillator

The operating frequency of SQ6211B is fixed at 45kHz and the maximum duty-cycle is up to 90%. It has a wide LEDs output voltage range for off-line LEDs lighting application.

### GATE Clamp

The GATE driver output voltage is clamped to 17V by an internal clamping circuit to protect the external power MOSFET. Those damages usually come from undesired over voltage GATE signals.

### Soft Driving

In order to reduce EMI interference, the SQ6211B is built in soft driving function. It helps designer save EMI components and cost.

### Lead-Edge Blanking

Cycle-by-cycle current limiting is offered in the SQ6211B. The switch current is detected by a sensing resistor into the CS pin. When the power switch is turned on, a turn-on spike will occur on this resistor. A 410ns leading-edge blanking (LEB) is built in to avoid false-termination of the switching pulse so that the external RC filtering is no longer needed. The current limit comparator is disabled and cannot turn off the external power MOSFET during the blanking period.

### Over Current Protection

The SQ6211B has an over current protection function on CS pin. The switch current is detected by a sensing resistor into the CS pin, when the voltage drop of sensing resistor is larger than an OCP voltage level (typically 0.8V), the GATE pin will keep on low level result in turning off the external power MOSFET. Then V<sub>DD</sub> is lower than V<sub>DD\_MIN</sub> level, the controller resets again. This OCP protection mode is auto-recovery type.

## Over Voltage Protection

To prevent the LEDs driver from being damaged, the YH6811 is implemented an OVP function on VDD pin. When the VDD voltage is higher than the OVP threshold voltage (typically 28V), the output gate driver circuit will be shut down immediately to stop the switching of external power MOSFET, until the VDD voltage drops below the UVLO threshold (typically 8V), and then start again. The YH6811 is working in an auto-recovery mode as shown in Figure 3.

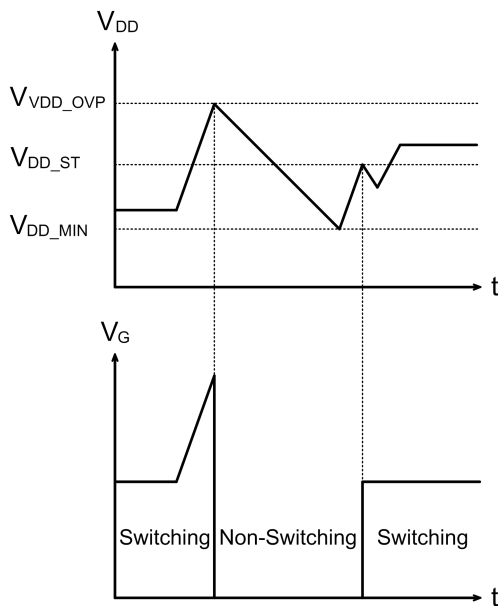

**Figure 3. Waveform of Over Voltage Protection Over Temperature Protection**

To prevent the LEDs driver from being damaged, the YH6811 has a built-in OTP to detect the overheated condition on the die. When the junction temperature reaches over  $T_{SD}$  (typically  $150^{\circ}C$ ), the YH6811 stops switching and waits for the lower threshold temperature ( $T_{SD} - \Delta T_{SD}$ , typically  $120^{\circ}C$ ) to start it again. The OTP can be observed in the real applications. When it reaches OTP upper threshold temperature, the LEDs blink off. It cools off below the lower threshold temperature, the LEDs blink on.

## Linear Dimming and External OTP

The typical application for DIM pin is shown in Figure 4. The NTC thermistor is setting as an external OTP protection. In this DIM pin, there is one comparator for latch off mode protection.

The application of DIM pin is described as below :

1. Output minimum pulse mode protection is less than 0.6V.
2. The linear dimming is between 0.6V and 3.0V.
3. The normal operating area is higher than 3.0V. User can open this DIM pin when the output minimum pulse mode and the linear dimming are not required.

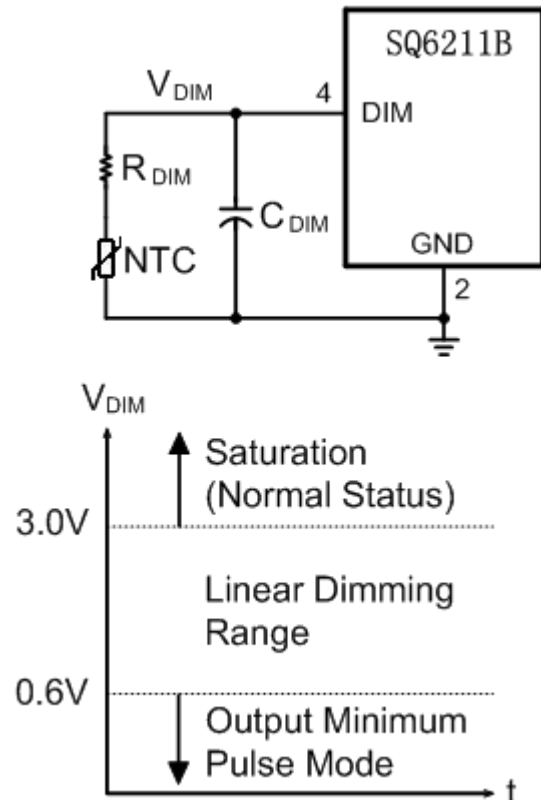
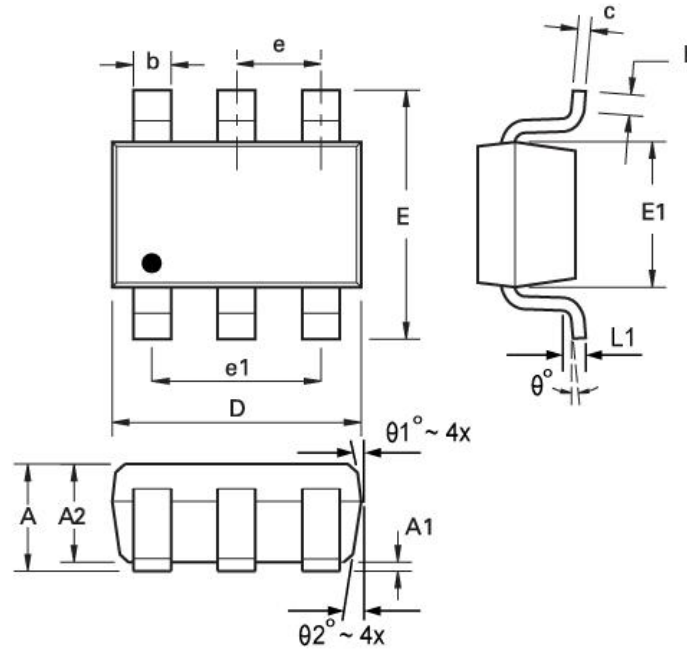

**Figure 4. Linear Dimming and External OTP**



## Package Outline Dimension

### 6-Lead Plastic Small SOT23 Package



Symbol	Dimensions in millimeters		Dimensions in inches	
	Min	Max	Min	Max
A	1.00	1.20	0.0394	0.0472
A1	0.01	0.09	0.0004	0.0035
A2	1.00	1.12	0.0394	0.0441
b	0.35	0.50	0.0138	0.0197
c	0.10	0.20	0.0039	0.0079
D	2.80	3.00	0.1102	0.1181
E	2.60	3.00	0.1024	0.1181
E1	1.50	1.70	0.0591	0.0669
e	0.90	1.00	0.0354	0.0394
e1	1.90 BSC		0.0748 BSC	
L	0.35	0.55	0.0138	0.0217
L1	0.25 BSC		0.0098 BSC	
$\theta^\circ$	0	8	0	8
$\theta1^\circ$	4	6	4	6
$\theta2^\circ$	6	10	6	10





---

## Packing Method Informaion

Product Order Code	Package Type	Quantity of Packing			
		PCs/Tape & Reel	Reel/Box	Box/Carton	PCs/Carton
SQ6211B	SOT23-6	3,000	4	12	144,000

## X-ON Electronics

Largest Supplier of Electrical and Electronic Components

*Click to view similar products for [LED Display Drivers](#) category:*

*Click to view products by [Sequoia](#) manufacturer:*

Other Similar products are found below :

[STP16CPP05XTTR](#) [SCT2027CSSG](#) [KP22306WGA](#) [KP1199AWPA](#) [KP1199BWPA](#) [GN1628T](#) [BCT3236EGH-TR](#) [HT1628BRWZ](#)  
[KP1192SPA](#) [KP1182SPA](#) [KP1262FSPA](#) [KP1072LSPA](#) [KP1191SPA](#) [KP18001WPA](#) [KP1070LSPA](#) [KP1221SPA](#) [KP107ALSPA](#) [GN1640T](#)  
[MBI5253GP-A](#) [WS90561T](#) [S7P](#) [WS9821B](#) [S7P](#) [WS9032GS7P](#) [LYT3315D](#) [M08888G-11](#) [M08890G-13](#) [SCT2001ASIG](#) [SCT2024CSOG](#)  
[SCT2024CSSG](#) [AL8400QSE-7](#) [PR4401](#) [PR4403](#) [PCA9685PW](#) [STP16CPC05XTTR](#) [WS2821B](#) [PR4402](#) [M08898G-13](#) [RT8471GJ5](#)  
[TLC59482DBQR](#) [ISL97634IRT14Z-TK](#) [AW36413CSR](#) [LP5562TMX](#) [WS2818B](#) [BCR401R](#) [BCR401U](#) [BCR402U](#) [SCT2004CSOG](#)  
[SCT2026CSOG](#) [SCT2026CSSG](#) [SCT2932F](#) [SCT2932J](#)