

SERPAC 033i (exploded isometric)

Electronic Enclosures

- Click on image to show toolbar. Use ▶ || to Play/Pause Animation.
- Left click and drag on image to move 3D model.

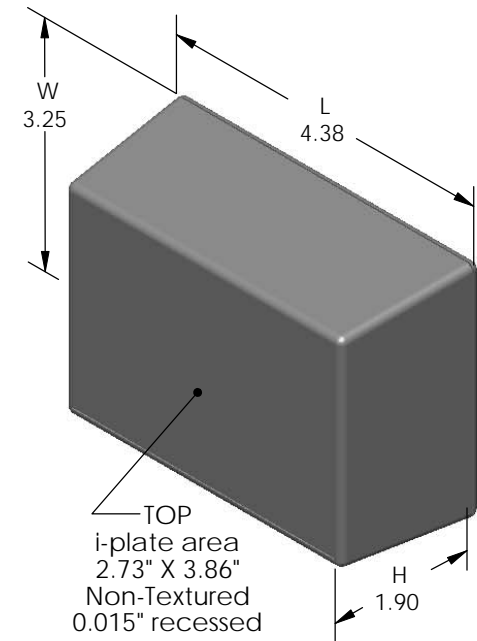

3D model options:

- Zoom in & out with center wheel.
- Pause at any moment to view and or print views.
- Change the views to ortho and section views if needed from the Views pull down menu.
- Explore options included in the tool bar like: Views, Transparency of model, Lighting type, etc.

PART NO.	DESCRIPTION (Included)	ACCESSORIES (Optional)	
3-3-i	TOP	PART NO.	DESCRIPTION
03	BOTTOM	51	Non-skid Feet
6005	#4X3/8" Self tapping (4)	330	Prototype grid board (bottom)
		430	Prototype clad board (bottom)

Notes: Enclosure weight .21 lbs / 94 gm

1) Enclosure meets or exceeds IP40 and NEMA 1

2) Circuit Board drawings can be download at:

TOP:
http://www.serpac.com/Accessories/CircuitBoard/drawings/X33_CB.pdf

BOTTOM:
<http://www.serpac.com/Accessories/CircuitBoard/drawings/330-430-cbg.pdf>

3) All components are RoHS Compliant.

ALL DIMENSIONS ARE ±.010" 3/17/10 (1 of 2)
619 Commercial Ave. Covina, CA 91723
 Ph. (626) 331-0517 Fx. (626) 331-8584 [serpac.com](http://www.serpac.com)

SERPAC 033i (user print)

Electronic Enclosures

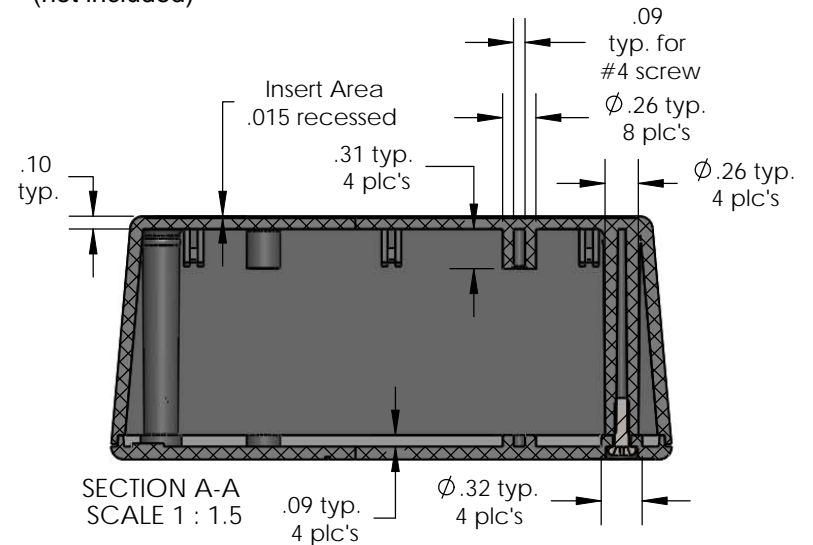
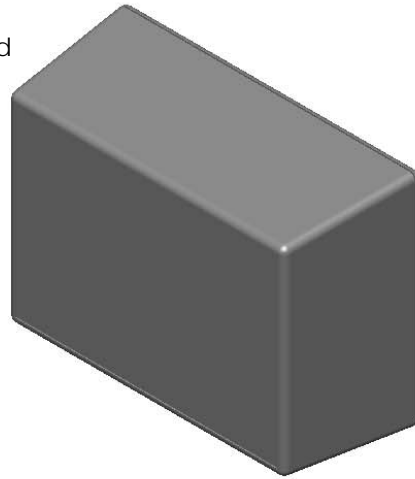
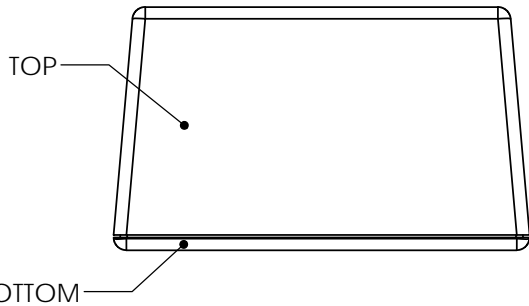
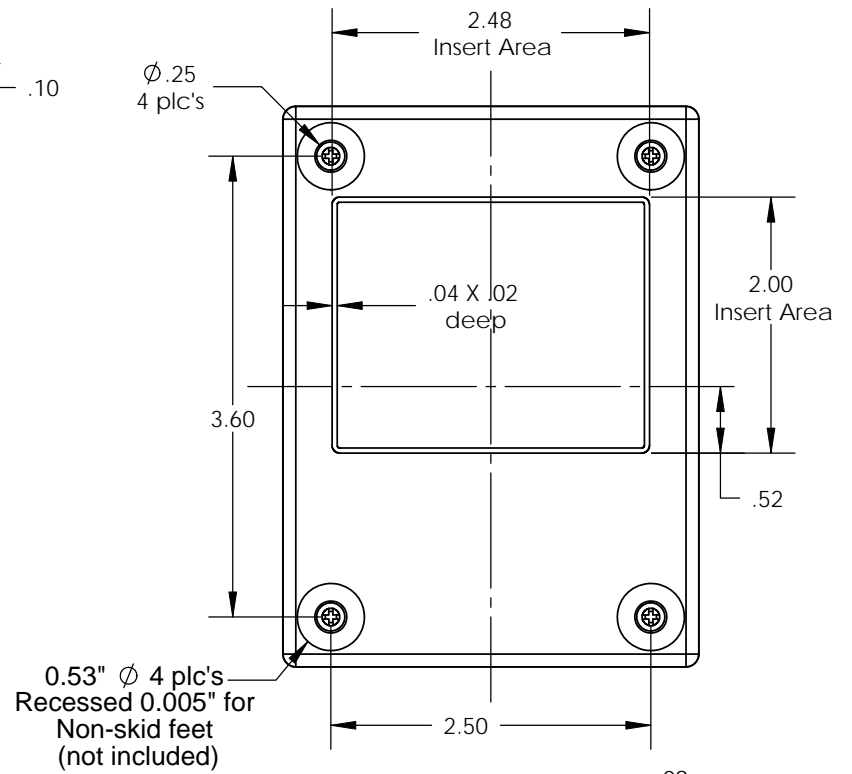
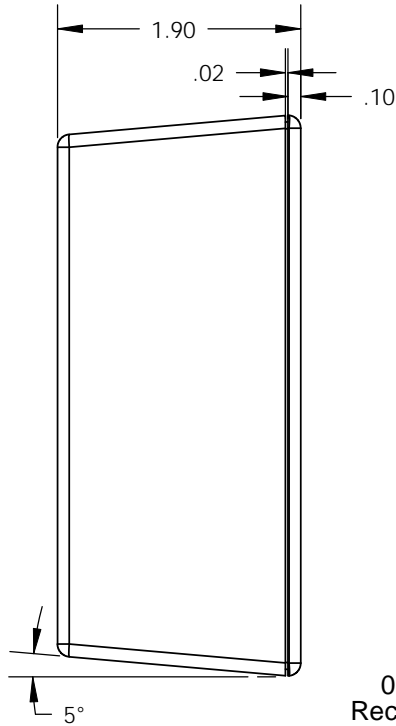
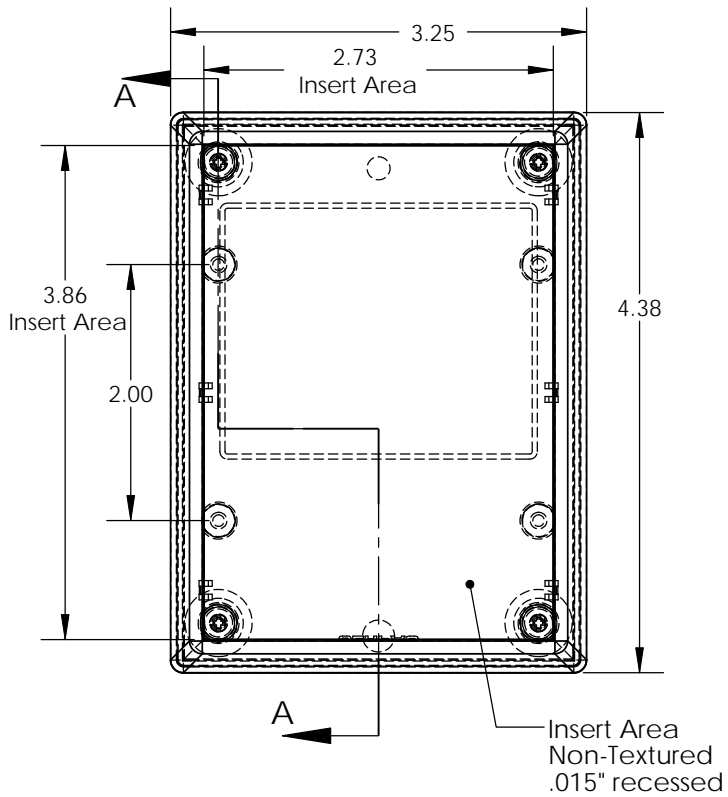

PART NO.	DESCRIPTION (Included)	ACCESSORIES (Optional)	
3-3-i	TOP	PART NO.	DESCRIPTION
03	BOTTOM	51	Non-skid Feet
6005	#4X3/8" self tapping (4)	330	Prototype grid board (bottom)
		430	Prototype clad board (bottom)

Notes: Enclosure weight .21 lbs / 94 gm
1) Enclosure meets or exceeds IP40 and NEMA 1
2) Circuit Board drawings can be download at:

TOP:
http://www.serpac.com/Accessories/CircuitBoard/drawings/X33_CB.pdf

BOTTOM:
<http://www.serpac.com/Accessories/CircuitBoard/drawings/330-430-cbg.pdf>

3) All components are RoHS Compliant.

ALL DIMENSIONS ARE ± .010" 3/17/10 (2 of 2)
619 Commercial Ave. Covina, CA 91723
Ph. (626) 331-0517 Fx. (626) 331-8584 www.serpac.com

X-ON Electronics

Largest Supplier of Electrical and Electronic Components

Click to view similar products for [Enclosures for Industrial Automation](#) category:

Click to view products by [SERPAC](#) manufacturer:

Other Similar products are found below :

[116-508](#) [130-008](#) [190-005](#) [2202307](#) [2901699](#) [2790318](#) [WM011RI,BK](#) [WM052I,GY](#) [WM093RI,BK](#) [5030266](#) [WM053R,BK](#) [WM032I,BK](#)
[2909989](#) [120-908](#) [150-007](#) [790-207](#) [2200095](#) [111-012](#) [127-408](#) [802-407](#) [115-401](#) [795-001](#) [790-211](#) [733-820](#) [BW67DBKCSYL](#)
[CX68DBKANG](#) [CXL68DBKAYL](#) [CXL65DBKANG](#) [BW68DBKCSBL](#) [DPH-28714-C](#) [135-007](#) [721-032](#) [1103440](#) [1037322](#) [1167159](#)
[1158978](#) [1158981](#) [1158982](#) [2202667](#) [1017444](#) [BWA-AH664](#) [100-403-91](#) [100-405-01](#) [101-003-91](#) [101-004-91](#) [101-506-01](#) [WM012I,GY](#)
[WM013I,AL](#) [WM052RI,GY](#) [WM093RI,GY](#)