



# Strato Pi Mini User Guide

*March 2019*

*Revision 003*

***SPBM20X Strato Pi Mini board***



Safety information	4
Qualified personnel	4
Hazard levels	4
Safety instructions	5
General safety instructions	5
Battery	5
Introduction	7
Features	7
Usage and connections	8
Hardware Installation	8
Replacing the RTC backup battery	8
Terminal block	10
Device identification	10
Power supply	11
Relay output	12
Dedicated GPIO pins	12
Software installation and configuration	13
Strato Pi Mini utility	13
Real Time Clock software	13
Testing the Real Time Clock	14
Using Strato Pi Mini	15
Real Time Clock	15
ATECC608A Secure Element	15
Buzzer	15
Block diagram	17
Technical specifications	18
Dimensions	19
Disposal	20
Installation and use restrictions	20
Standards and regulations	20
Safety instructions	20
Set-up	20
Conformity Information	21
EU	21
USA	21
CANADA	22



**Be sure to always remove the power supply before connecting or disconnecting the Strato Pi Mini board to Raspberry Pi.**

**Follow all applicable electrical safety standards, guidelines, specifications and regulations for installation, wiring and operations of Strato Pi Mini.**

**Carefully and fully read this Strato Pi Mini user guide before installation.**

Strato Pi Mini is not authorised for use in safety-critical applications where a failure of the product would reasonably be expected to cause personal injury or death. Safety-critical applications include, without limitation, life support devices and systems, equipment or systems for the operation of nuclear facilities and weapons systems. Strato Pi Mini is neither designed nor intended for use in critical military or aerospace applications or environments and for automotive applications or environment. Customer acknowledges and agrees that any such use of Strato Pi Mini is solely at Customer's risk, and that Customer is solely responsible for compliance with all legal and regulatory requirements in connection with such use.

Sfera Labs S.r.l. may make changes to specifications and product descriptions at any time, without notice. The product information on the web site or materials is subject to change without notice.

Please download and read the Sfera Labs Terms and Conditions document available at:

**<http://www.sferalabs.cc>**

Strato and Sfera Labs are trademarks of Sfera Labs S.r.l. Other brands and names may be claimed as the property of others.

Copyright © 2016-2019 Sfera Labs S.r.l. All rights reserved.

## Safety information

Carefully and fully read this user guide before installation and retain it for future reference.

### Qualified personnel

The product described in this manual must be operated only by personnel qualified for the specific task and installation environment, in accordance with all relevant documentation and safety instructions. A qualified person should be capable of fully identifying all installation and operation risks and avoid potential hazards when working with this product.

### Hazard levels

This manual contains information you must observe to ensure your personal safety and prevent damage to property. Safety information in this manual are highlighted by the safety symbols below, graded according to the degree of danger.



Indicates a hazardous situation which, if not avoided, **will** result in death or serious personal injury.



Indicates a hazardous situation which, if not avoided, **may** result in death or serious personal injury.



Indicates a hazardous situation which, if not avoided, can result in minor or moderate personal injury.



Indicates a situation which, if not avoided, can result in damage of property.

## Safety instructions

---

### General safety instructions

Protect the unit against moisture, dirt and any kind of damage during transport, storage and operation. Do not operate the unit outside the specified technical data.

Never open the housing. If not otherwise specified, install in closed housing (e.g. distribution cabinet). Earth the unit at the terminals provided, if existing, for this purpose. Do not obstruct cooling of the unit. Keep out of the reach of children.



Life threatening voltages are present within and around an open control cabinet.

When installing this product in a control cabinet or any other areas where dangerous voltages are present, always switch off the power supply to the cabinet or equipment.



Risk of fire if not installed and operated properly.

Follow all applicable electrical safety standards, guidelines, specifications and regulations for installation, wiring and operations of this product.

The Raspberry Pi board could generate a substantial amount of heat when the software forces the CPU and/or GPU to operate at high load levels. Ensure that the product is properly installed and ventilated to prevent overheating.



The connection of expansion devices to this product may damage the product and other connected systems, and may violate safety rules and regulations regarding radio interference and electromagnetic compatibility.

Use only appropriate tools when installing this product. Using excessive force with tools may damage the product, alter its characteristics or degrade its safety.

---

### Battery

This product uses a small lithium non-rechargeable coin battery to power its internal real time clock (RTC).



Improper handling of lithium batteries can result in an explosion of the batteries and/or release of harmful substances.

Worn-out or defective batteries can compromise the function of this product.

Replace the RTC lithium battery before it is completely discharged. The lithium battery must be replaced only with an identical battery. See the "Replacing the RTC backup battery" section for instructions.

Do not throw lithium batteries into fire, do not solder on the cell body, do not recharge, do not open, do not short-circuit, do not reverse polarity, do not heat above 100°C and protect from direct sunlight, moisture and condensation.

Dispose of used batteries according to local regulations and the battery manufacturer's instructions.

## Introduction

Strato Pi Mini is an expansion board that enhances the Raspberry Pi 2 Model B and Raspberry Pi 3 Model B or B+ with a rugged power supply, a real time clock with on-board lithium back-up battery, a buzzer and the Microchip ATECC608A secure element chip.

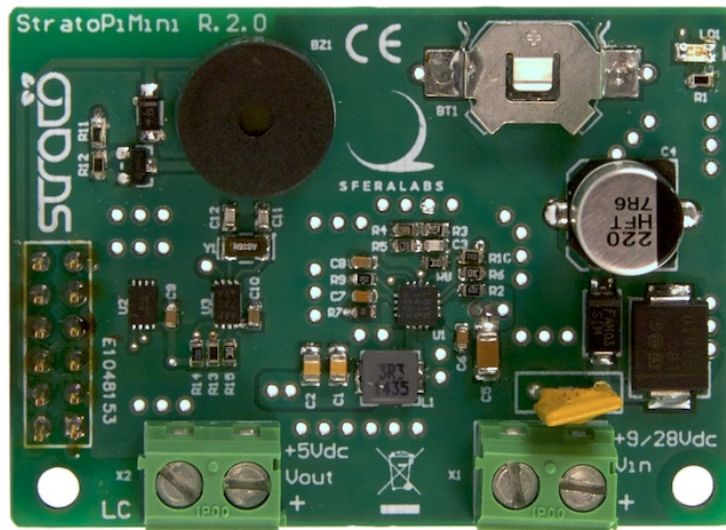

## Features

- ✓ 9-28Vdc power supply, with surge and reverse polarity protection, and 1.1A resettable fuse
- ✓ real time clock with replaceable CR1025 Lithium / Manganese Dioxide back-up battery
- ✓ embedded Microchip ATECC608A secure element chip
- ✓ on-board buzzer, connected to an I/O pin of the Raspberry Pi board, for acoustic feedback
- ✓ on-board power-on LED
- ✓ high-current stabilised 5Vdc output terminal block
- ✓ power supply on screw terminal block.



## Usage and connections

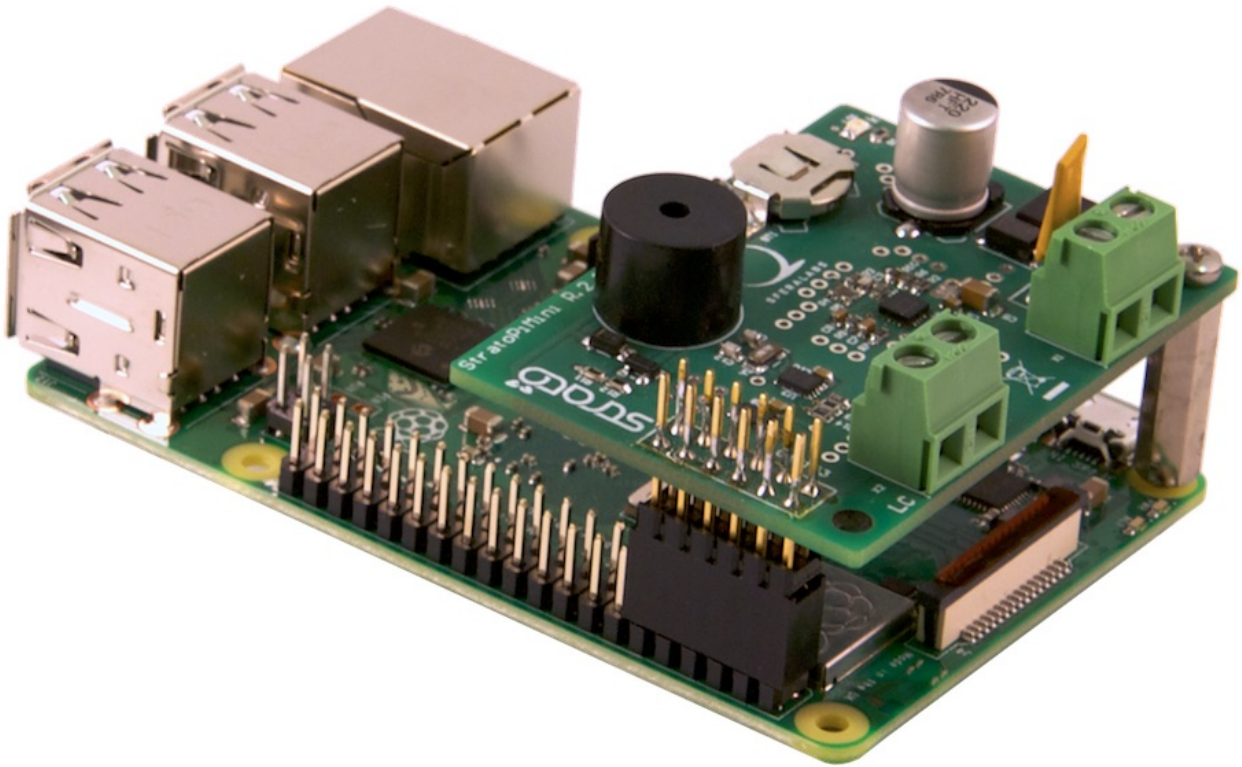

STRATO PI MINI BOARD INSTALLED ON THE RASPBERRY PI

### Hardware Installation

The Strato Pi Mini board is supplied with all connectors pre-installed. No soldering is required. You should connect Strato Pi to Raspberry Pi aligning the GPIO connector. Use appropriate turrets/spacers to firmly bolt the two boards together, ensuring that no conductive part of one board touches any part of the other board.

The Strato Pi Mini board 12-way pass-through connector must be aligned with the left side of the Pi's GPIO connector (pins 1-12).

## NOTICE

The GPIO connector of the Strato Pi Mini board must be perfectly aligned to the Raspberry Pi's GPIO pins. Turning on the Raspberry Pi and/or the Strato Pi Mini board with the GPIO not correctly connected will damage both the Raspberry Pi and Strato Pi Mini board.

### Replacing the RTC backup battery

Strato Pi Mini has a hardware real time clock with a dedicated long-life non-rechargeable back-up battery.

Strato Pi Mini is shipped with a **CR1025** Lithium / Manganese Dioxide (Li/MnO<sub>2</sub>) battery installed.

The battery is only used to power the RTC chip when the main power is not available (when the Raspberry Pi is off). Depending on operating conditions it should last up to two years if the Strato Pi board is not powered, more if the Strato Pi Mini receives external power.



## WARNING

Improper handling of lithium batteries can result in an explosion of the batteries and/or release of harmful substances.

Worn-out or defective batteries can compromise the function of this product.

**KEEP OUT OF REACH OF CHILDREN.** Swallowing may lead to serious injury or death in as little as 2 hours due to chemical burns and potential perforation of the esophagus. Immediately see doctor.

Replace the RTC lithium battery before it is completely discharged. Replace the battery every 5 years even if the battery is still working properly. The lithium battery must be replaced only with an identical **CR1025** Lithium / Manganese Dioxide (Li/MnO<sub>2</sub>) battery.

Do not throw lithium batteries into fire, do not solder on the cell body, do not recharge, do not open, do not short-circuit, do not reverse polarity, do not heat above 100°C and protect from direct sunlight, moisture and condensation.

Dispose of used batteries according to local regulations and the battery manufacturer's instructions.

The RTC backup battery holder is soldered to the top layer of the circuit board, next to the GPIO connector.

## NOTICE

Before accessing the Strato Pi Mini board, disconnect all power sources and any connection to external devices, including USB cables.

Use a non-conductive pin or small tool to help extract the battery from its holder. Insert the new battery with a gentle push. You don't need tools to insert the battery. The battery is held into place by a spring contact.

Be sure to insert the battery so that the positive (+) terminal of the battery is in contact with the outer body of the battery holder, and the negative (-) terminal is in contact with the contact pad of the circuit board.

Reversing the battery polarity may damage the product.

The real time clock will reset its time immediately when the RTC backup battery is disconnected.

## Terminal block

A 2-way terminal block is used for the input voltage connection.

An additional 2-way terminal block is used to make the internal 5V high current output supplied to the Raspberry Pi available for other external loads.

The maximum conductor cross section is 2.08 mm<sup>2</sup> (14 AWG). Recommended stripping length is 6 mm. Screw thread is M3. Never exceed 0.5 Nm torque when tightening the screws.

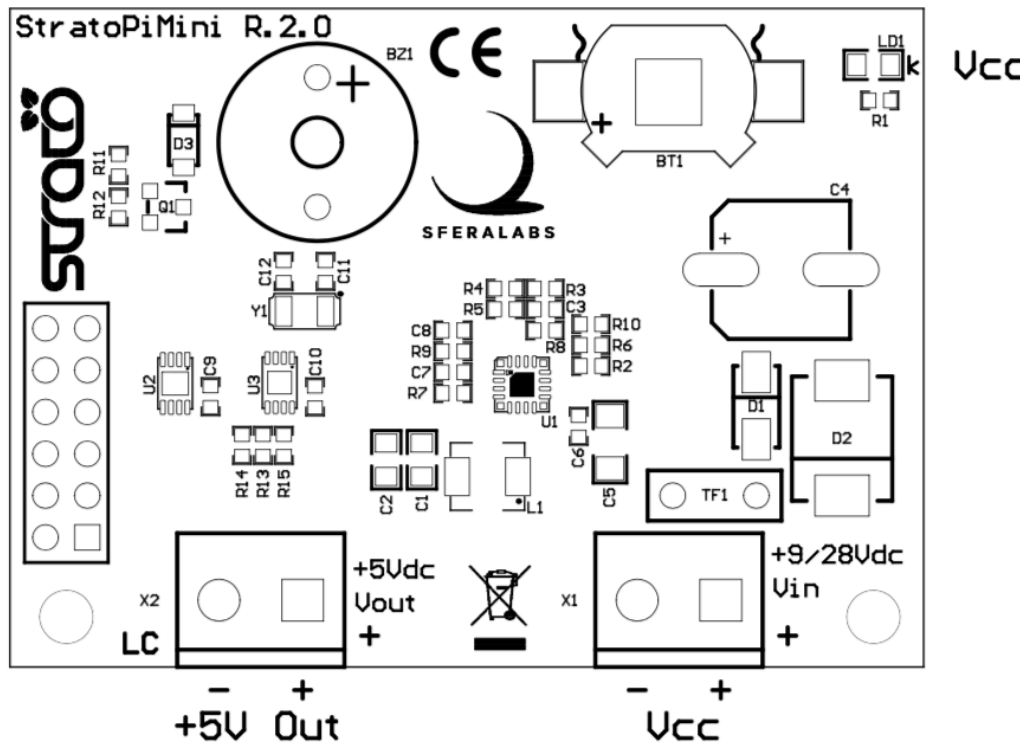

THE STRATO PI MINI CIRCUIT BOARD

## Device identification

The device can be identified with the information provided in the rating and identification plate, placed on the device packaging.



Strato Pi Mini board

S/N: SPBM20X-19060000

Sfera Labs S.r.l.  
Str 4 Pal Q6 - 20089  
Rozzano (MI) Italy  
www.sferalabs.cc

MADE IN ITALY

P/N: SPBM20X  
LOT: 190601  
DATE: 1906  
COO: IT  
QTY: 1



FCC - CAN ICES-3 (B)/NMB-3(B)

SFERALABS

This device complies with Part 15 of the FCC Rules. Operation is subject to the following two conditions: (1) this device may not cause harmful interference, and (2) this device must accept any interference received, including interference that may cause undesired operation

EXAMPLE RATING AND IDENTIFICATION PLATE

## Power supply

Strato Pi Mini be powered with DC voltage only:

✓ DC: nominal voltage range 9.0V to 28.0V.

Respect the correct polarity shown in the schematic diagram (+ -). The power supply circuit implements reverse polarity protection using an auto resetting fuse and surge protection up to  $\pm 500V/20\Omega$  1.2/50 $\mu$ s.

A blue on-board LED is lit when power supply is available.

When a Strato Pi Mini board is used, never connect the Raspberry Pi micro-USB power plug.

The Strato Pi Mini power supply stage is optimised to deliver up to 2.0A continuous 5V output to the Raspberry Pi. Because Strato Pi Mini has an 1.1A resettable fuses (polyfuse) on the power supply line, the maximum current that its regulator can deliver is also limited by this fuse, and depends on the input voltage. The following table lists the typical measured output current of the power supply stage at different input voltages, and the corresponding input current. At high input voltage levels, the voltage regulator's thermal protection becomes the limiting factor.

The voltage regulator can supply up to 3.0A 5V output short duration current peaks (<1sec).

		9V	12V	24V
lout	Vout	lin	lin	lin
0.1	5.00	0.07	0.06	0.03
0.5	4.98	0.33	0.25	0.13
1	4.95	0.69	0.50	0.25
1.3	4.93	0.93	0.66	0.33
1.5	4.92	1.11 FUSE	0.77	0.39
1.6	4.91		0.83	0.41
1.7	4.91		0.89	0.44
1.8	4.91		0.95	0.47
1.9	4.91		1.01	0.50
2	4.91		1.08 REG	0.54 REG

**STRATO PI MINI POWER SUPPLY STAGE TYPICAL IN/OUT VOLTAGE AND CURRENT**

## Relay output

Strato Pi Mini has one relay with change-over (CO), Single Pole Double Throw (SPDT) terminals.

The relay itself is rated for a 6A maximum current but, due to the terminal block size and isolation requirements, the output contacts are rated for 0.6A maximum current at 65V (DC).

The relay is controlled by a GPIO pin of the Raspberry Pi.

## Dedicated GPIO pins

Strato Pi Mini uses some of the Raspberry Pi's GPIO pins.

GPIO pin	Direction	Description
GPIO2/SDA		I <sup>2</sup> C SDA line for the real time clock and ATECC608 secure chip
GPIO3/SCL		I <sup>2</sup> C SCL line for the real time clock and ATECC608 secure chip
GPIO17	out	set to high to sound the buzzer

The GPIO17 pin should not be used for other functions.

## Software installation and configuration

All features of Strato Pi Mini, except the real time clock and the ATECC608 secure element, are controlled via dedicated GPIO pins and can be used with any operating system and programming language that supports the GPIO pins control on Raspberry Pi. The real time clock and the ATECC608 are interfaced via the I<sup>2</sup>C serial bus.

The following software installation notes are based on the Raspbian Stretch operating system.

### Strato Pi Mini utility

The Strato Pi utility is a simple command-line script to control Strato Pi's buzzer.

Run the following commands to download and install the Strato Pi utility:

```
$ cd /usr/local/bin
$ sudo wget http://sferalabs.cc/files/stratopimini/strato
$ sudo chmod 755 strato
```

You can run the Strato Pi utility without arguments to print its options:

```
$ strato
Usage: strato beep on|off|length_millis|length_millis pause_millis repeats
```

All commands should be run as superuser, so always use `sudo` to run `strato`.

### Real Time Clock software

The RTC is based on the Microchip MCP79410 module and is connected to the Raspberry Pi via its I<sup>2</sup>C serial bus.

Before downloading the installation utility, you should enable I<sup>2</sup>C and install the “i2c-tools” package.

To enable I<sup>2</sup>C, run the “raspi-config” configuration utility:

```
$ sudo raspi-config
```

Then go to “Advanced Options”, “I<sup>2</sup>C” and select “yes” to enable the I<sup>2</sup>C interface, then reboot your Raspberry Pi.

To install the “i2c-tools” package:

```
$ sudo apt-get update
$ sudo apt-get install i2c-tools
```

With these prerequisite installs completed, you should download and run Strato Pi's installation script:

```
$ cd
$ wget http://sferalabs.cc/files/strato/rtc-install
$ chmod 755 rtc-install
$ sudo ./rtc-install
```

If the script completes with no errors, delete the installation script and reboot:

```
$ rm rtc-install
```

```
$ sudo reboot
```

## Testing the Real Time Clock

Assuming you are connected to the Internet and your Pi was able to reach a public NTP (Network Time Protocol) server, you should see the current date and time using the “date” command:

```
$ date
Thu Dec 10 18:02:32 CET 2015
```

Also check the date and time stored in the hardware clock:

```
$ sudo hwclock -r
Thu 10 Dec 2015 06:03:01 PM CET -0.546570 seconds
```

If the returned date and time is not correct, or “hwclock” returns an error, use the “-w” option to set the hardware clock to the current time:

```
$ sudo hwclock -w
```

Then recheck the time stored in the hardware clock to ensure it matches. Linux may have failed to automatically update the hardware clock after the last reboot if its internal registers contained invalid values.

If the RTC still doesn’t work, you should check if the Pi sees the RTC chip on the I<sup>2</sup>C bus. Run these two commands:

```
$ sudo modprobe -r rtc_ds1307
$ sudo i2cdetect 1
WARNING! This program can confuse your I2C bus, cause data loss and worse!
I will probe file /dev/i2c-1.
I will probe address range 0x03-0x77.
Continue? [Y/n]
 0  1  2  3  4  5  6  7  8  9  a  b  c  d  e  f
00:  --  --  --  --  --  --  --  --  --  --  --  --  --  --  --
10:  --  --  --  --  --  --  --  --  --  --  --  --  --  --  --
20:  --  --  --  --  --  --  --  --  --  --  --  --  --  --  --
30:  --  --  --  --  --  --  --  --  --  --  --  --  --  --  --
40:  --  --  --  --  --  --  --  --  --  --  --  --  --  --  --
50:  --  --  --  --  --  --  --  57  --  --  --  --  --  --  --
60:  60  --  --  --  --  --  --  --  --  --  --  --  --  --  6f
70:  --  --  --  --  --  --  --  --  --  --  --  --  --  --  --
```

You should see “6f” in the address list. This is the address of the RTC.

If the RTC address is detected, double check your software installation for issues at the Linux modules level.

Run the “lsmod” command to list the loaded modules and check that “i2c\_dev” and “i2c\_bcm2708” are both listed.

If the RTC address is not detected, the cause could be a hardware problem, on the Strato board or the Raspberry Pi. If you have another Pi or Strato board, try swapping them to isolate the faulty board.

# Using Strato Pi Mini

## Real Time Clock

Strato Pi Mini has a hardware real time clock with a dedicated long-life non-rechargeable back-up battery.

Once the RTC modules and configuration files are properly installed, you will simply use the date and time commands to control the hardware clock.

## ATECC608A Secure Element

Strato Pi Mini embeds the ATECC608A secure element chip from Microchip. The ATECC608A is connected to the Raspberry Pi via the I2C bus (default address: 0x60).

Its key features are:

- ✓ Cryptographic co-processor with secure hardware-based key storage
- ✓ Protected storage for up to 16 Keys, certificates or data
- ✓ Hardware support for asymmetric sign, verify, key agreement – ECDSA: FIPS186-3 Elliptic Curve Digital Signature
  - ✓ ECDH: FIPS SP800-56A Elliptic Curve Diffie-Hellman
  - ✓ NIST standard P256 elliptic curve support
- ✓ Hardware support for symmetric algorithms
  - ✓ SHA-256 & HMAC hash including off-chip context save/restore
  - ✓ AES-128: encrypt/decrypt, galois field multiply for GCM
- ✓ Networking key management support
  - ✓ Turnkey PRF/HKDF calculation for TLS 1.2 & 1.3
  - ✓ Ephemeral key generation and key agreement in SRAM – Small message encryption with keys entirely protected
- ✓ Secure boot support
  - ✓ Full ECDSA code signature validation, optional stored digest/signature – optional communication key disablement prior to secure boot
  - ✓ Encryption/Authentication for messages to prevent on-board attacks
- ✓ Internal high-quality FIPS 800-90 A/B/C Random Number Generator (RNG)
- ✓ Two high-endurance monotonic counters
- ✓ Guaranteed unique 72-bit serial number.

## Buzzer

Strato Pi Mini has an on-board buzzer that can be controlled using GPIO17. Simply set GPIO17 to high to emit a continuous sound, and back to low to stop. The buzzer is not intended to emit sound indefinitely and could be damaged doing so.

The Strato Pi utility has several commands to control the buzzer.



Buzzer on continuously:

```
$ sudo strato beep on
```

Buzzer off:

```
$ sudo strato beep off
```

Buzzer on for 500 milliseconds:

```
$ sudo strato beep 500
```

Buzzer on for 500 milliseconds, followed by 100 milliseconds pause, repeated three times:

```
$ sudo strato beep 500 100 3
```

# Block diagram

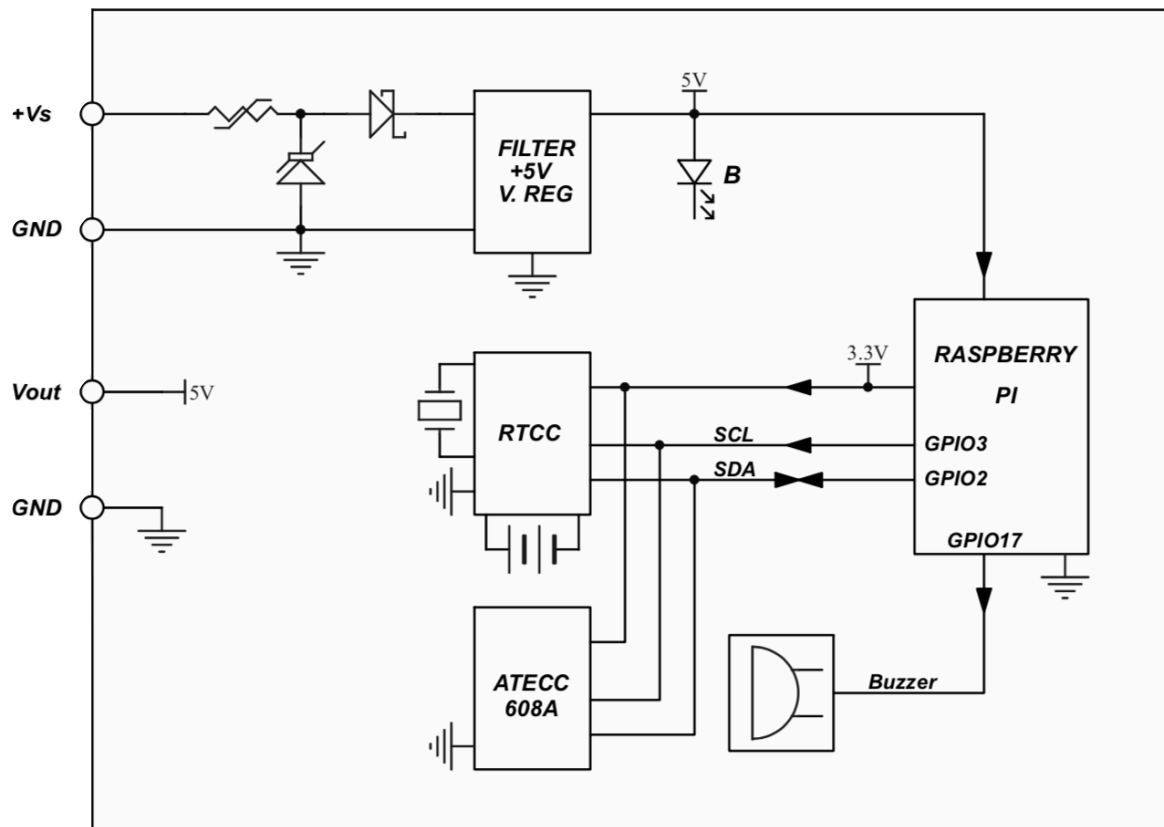

STRATO PI MINI BLOCK DIAGRAM

## Technical specifications

Power supply	9/28V $\overline{=}$ (VDC) Reverse polarity protection with auto resetting fuse. Surge protection up to $\pm 500V/20\Omega$ 1.2/50 $\mu$ s
5Vcc maximum output current (Ta 22 °C)	1.5 A @ 9V PS 2.0 A @ 12V PS 2.0 A @ 24V PS
Raspberry platform compatibility	Pi 3 Model B+ Pi 3 Model B Pi 2 Model B Pi 1 Model B+
Real time clock	Internal RTCC circuit with backup lithium battery. Only use CR1025 Lithium / Manganese Dioxide (Li/ MnO <sub>2</sub> ) batteries.  Expected battery life without main power supply: ~2 years
Dimensions (W x D)	40 x 56 mm
Operating temperature	0...+50 °C
Storage temperature	-20...+70 °C
Relative humidity	5% to 90% noncondensing
Weight	16 g (Strato Pi Mini board only)

# Dimensions

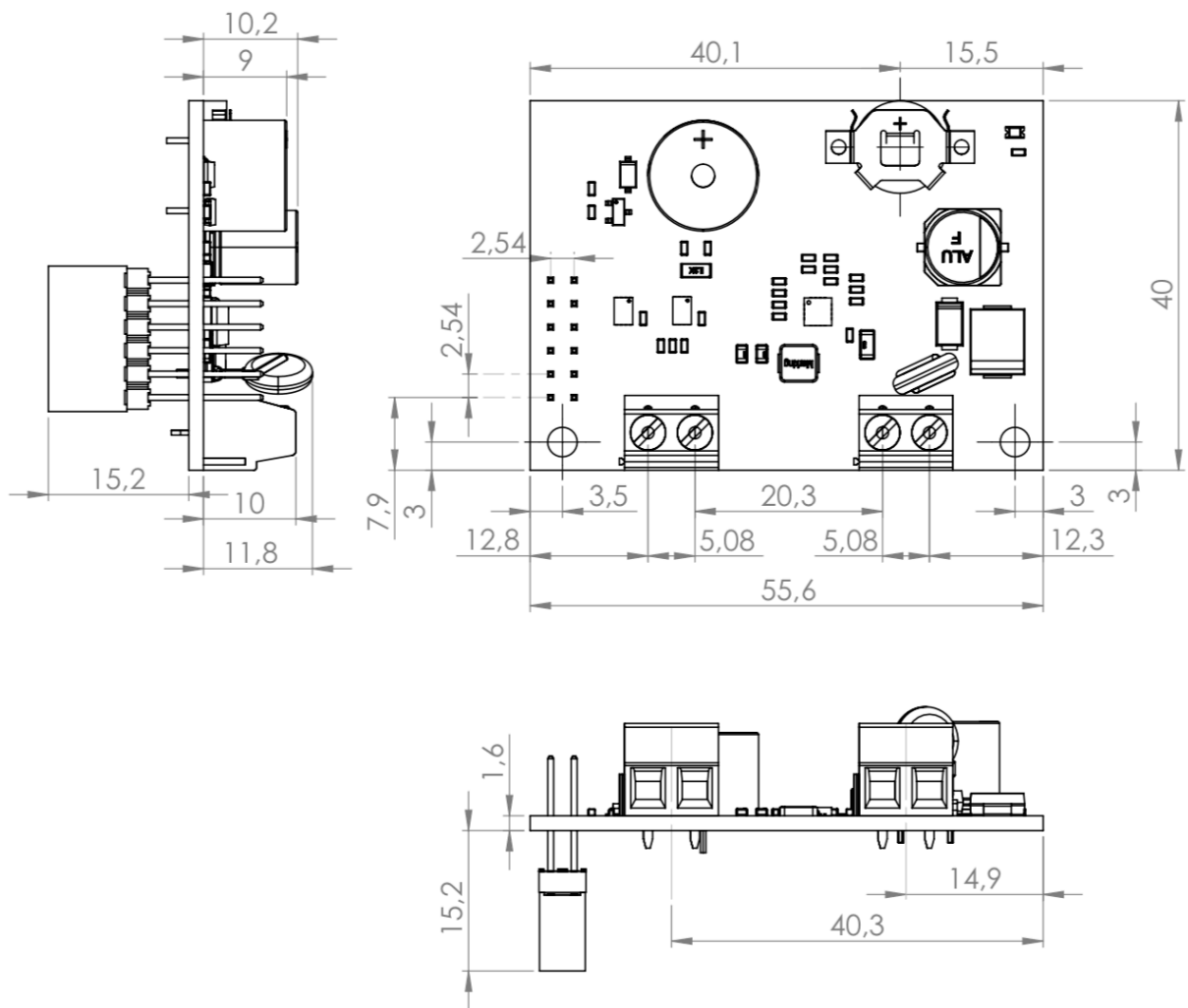

**DIMENSIONS (mm)**

## Disposal

### Waste Electrical & Electronic Equipment

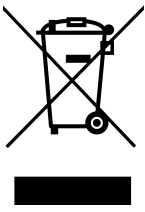

(Applicable in the European Union and other European countries with separate collection systems). This marking on the product, accessories or literature indicates that the product should not be disposed of with other household waste at the end of their working life. To prevent possible harm to the environment or human health from uncontrolled waste disposal, separate these items from other types of waste and recycle them responsibly to promote the sustainable reuse of material resources. Household users

should contact either the retailer where they purchased this product, or their local government office, for details of where and how they can take these items for environmentally safe recycling. This product and its electronic accessories should not be mixed with other commercial wastes for disposal.

Strato Pi Mini contains a small non rechargeable manganese dioxide lithium coin battery.

Always remove the battery before disposing of this product.

## Installation and use restrictions

### Standards and regulations

The design and the setting up of electrical systems must be performed according to the relevant standards, guidelines, specifications and regulations of the relevant country. The installation, configuration and programming of the devices must be carried out by trained personnel.

The installation and wiring of connected devices must be performed according to the recommendations of the manufacturers (reported on the specific data sheet of the product) and according to the applicable standards.

All the relevant safety regulations, e.g. accident prevention regulations, law on technical work equipment, must also be observed.

### Safety instructions

Carefully read the safety information section at the beginning of this document.

### Set-up

For the first installation of the device proceed according to the following procedure:

- ✓ make sure all power supplies are disconnected
- ✓ install and wire the device according to the schematic diagrams on the specific product user guide
- ✓ after completing the previous steps, switch on the power supply and other related circuits.

## Conformity Information

The declaration of conformity is available on the internet at the following address: <https://www.sferalabs.cc/strato-pi/>

### EU

This device complies with the essential requirements of the following directives and harmonised standards:

- ✓ 2014/30/UE (EMC)
- ✓ EN61000-6-2:2019 (EMC Immunity for industrial environments)
- ✓ EN61000-6-3:2007/A1:2011/AC:2012 (Emission for residential, commercial and light-industrial environments)
- ✓ 2011/65/UE (RoHS).

### USA

#### FCC Radio Frequency Interference Statement:

This equipment has been tested and found to comply with the limits for a Class B digital device, pursuant to part 15 of the FCC Rules. These limits are designed to provide reasonable protection against harmful interference in a residential installation. This equipment generates, uses and can radiate radio frequency energy and, if not installed and used in accordance with the instructions, may cause harmful interference to radio communications. However, there is no guarantee that interference will not occur in a particular installation. If this equipment does cause harmful interference to radio or television reception, which can be determined by turning the equipment off and on, the user is encouraged to try to correct the interference by one or more of the following measures:

- Reorient or relocate the receiving antenna
- Increase the separation between the equipment and receiver
- Connect the equipment into an outlet on a circuit different from that to which the receiver is connected
- Consult the dealer or an experienced radio/TV technician for help.

#### Shielded Cables:

Shielded cables must be used with this equipment to maintain compliance with FCC regulations.

#### Modifications:

Changes or modifications not expressly approved by the party responsible for compliance could void the user's authority to operate the equipment.

**Conditions of Operations:**

This device complies with Part 15 of the FCC Rules. Operation is subject to the following two conditions: (1) this device may not cause harmful interference, and (2) this device must accept any interference received, including interference that may cause undesired operation.

**CANADA**

This Class B digital apparatus complies with Canadian ICES-003(B).

Cet appareil numérique de la classe B est conforme à la norme NMB-003(B) du Canada.

**RCM AUSTRALIA / NEW ZEALAND**

This product meets the requirements of the standard EN 61000-6-3:2007/A1:2011/AC:2012 - Emission for residential, commercial and light-industrial environments.

## X-ON Electronics

Largest Supplier of Electrical and Electronic Components

*Click to view similar products for [Controllers](#) category:*

*Click to view products by [Sfera Labs](#) manufacturer:*

Other Similar products are found below :

[61FGPN8DAC120](#) [CV500SLK21](#) [70177-1011](#) [F03-03 HAS C](#) [F03-31](#) [81550401](#) [FT1A-C12RA-W](#) [88981106](#) [H2CAC24A](#) [H2CRSAC110B](#)  
[R88A-CRGB003CR-E](#) [R88ARR080100S](#) [R88A-TK01K](#) [DCN1-1](#) [AFP0RT32CT](#) [DRT2ID08C](#) [DTB4896VRE](#) [DTB9696CVE](#)  
[DTB9696LVE](#) [E53-AZ01](#) [E53E01](#) [E53E8C](#) [E5C4Q40J999FAC120](#) [E5CWLQ1TCAC100240](#) [E5GNQ03PFLKACDC24](#) [B300LKL21](#)  
[NSCXDC1V3](#) [NSH5-232CW-3M](#) [NT20SST122BV1](#) [NV-CN001](#) [OAS-160-N](#) [C40PEDRA](#) [K31S6](#) [K33-L1B](#) [K3MA-F](#) [100-240VAC](#)  
[K3TX-AD31A](#) [89750101](#) [L595020](#) [SRM1-C02](#) [SRS2-1](#) [G32X-V2K](#) [26546803](#) [26546805](#) [PWRA440A](#) [CPM1AETL03CH](#) [CV500SLK11](#)  
[3G2A5BI081](#) [3G2A5IA122](#) [3G2A5LK010E](#) [3G2A5OA223](#)