

GENERAL DESCRIPTION

The SGM6607A is a monolithic high voltage switching regulator with integrated 1.2A, 40V power MOSFET. This device can be configured in several standard switching regulator topologies, including boost and SEPIC. The device has a wide input voltage range to support applications with input voltage from multi-cell batteries or regulated 5V, 12V power rails.

The SGM6607A operates at a 1.1MHz switching frequency, allowing the use of low-profile inductors and low-value ceramic input and output capacitors. External loop compensation components give the user flexibility to optimize loop compensation and transient response. The device has built-in protection features, such as cycle-by-cycle over-current limit, soft-start and thermal shutdown.

The SGM6607A is available in Green TDFN-2x2-6AL and TSOT-23-6 packages and is rated over the -40°C to +85°C temperature range.

FEATURES

- 3V to 20V Input Voltage Range
- High Output Voltage: Up to 38V
- 1.2A Integrated Switch
- 1.1MHz Fixed Switching Frequency
- 12V at 300mA and 24V at 150mA from 5V Input
- Up to 93% Efficiency
- Skip-Switching for Light Load
- Built-in Soft-Start Function
- 500kΩ Pull-Down Resistor on EN Pin
- -40°C to +85°C Operating Temperature Range
- Available in Green TDFN-2x2-6AL and TSOT-23-6 Packages

APPLICATIONS

Cell Phones
Portable Equipment

TYPICAL APPLICATION

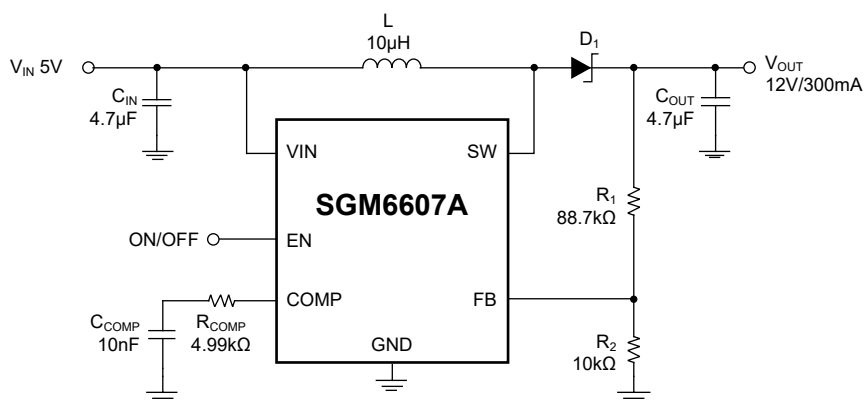

Figure 1. Typical Application Circuit

PACKAGE/ORDERING INFORMATION

MODEL	PACKAGE DESCRIPTION	SPECIFIED TEMPERATURE RANGE	ORDERING NUMBER	PACKAGE MARKING	PACKING OPTION
SGM6607A	TDFN-2x2-6AL	-40°C to +85°C	SGM6607AYTDI6G/TR	R17 XXXX	Tape and Reel, 3000
	TSOT-23-6	-40°C to +85°C	SGM6607AYTN6G/TR	RA9XX	Tape and Reel, 3000

MARKING INFORMATION

NOTE: XX = Date Code, XXXX = Date Code and Trace Code.

TSOT-23-6

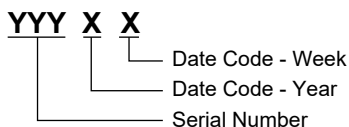

TDFN-2x2-6AL

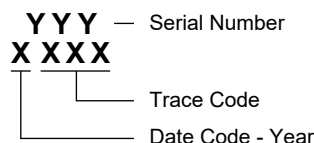

Green (RoHS & HSF): SG Micro Corp defines "Green" to mean Pb-Free (RoHS compatible) and free of halogen substances. If you have additional comments or questions, please contact your SGMICRO representative directly.

ABSOLUTE MAXIMUM RATINGS

- Supply Voltage on VIN..... -0.3V to 22V
- Voltage on EN..... -0.3V to 6V
- Voltages on FB and COMP..... -0.3V to 3V
- Voltage on SW -0.3V to 40V
- Junction Temperature.....+150°C
- Package Thermal Resistance
- TDFN-2x2-6AL, θ_{JA} 78°C/W
- TSOT-23-6, θ_{JA} 190°C/W
- Storage Temperature Range -65°C to +150°C
- Lead Temperature (Soldering, 10s).....+260°C
- ESD Susceptibility
- HBM..... 4000V
- CDM 1000V

RECOMMENDED OPERATING CONDITIONS

- Input Voltage Range3V to 20V
- Output Voltage Range $1.1 \times V_{IN}$ to 38V
- Operating Ambient Temperature Range..... -40°C to +85°C
- Operating Junction Temperature Range..... -40°C to +125°C

OVERSTRESS CAUTION

Stresses beyond those listed in Absolute Maximum Ratings may cause permanent damage to the device. Exposure to absolute maximum rating conditions for extended periods may affect reliability. Functional operation of the device at any conditions beyond those indicated in the Recommended Operating Conditions section is not implied.

ESD SENSITIVITY CAUTION

This integrated circuit can be damaged if ESD protections are not considered carefully. SGMICRO recommends that all integrated circuits be handled with appropriate precautions. Failure to observe proper handling and installation procedures can cause damage. ESD damage can range from subtle performance degradation to complete device failure. Precision integrated circuits may be more susceptible to damage because even small parametric changes could cause the device not to meet the published specifications.

DISCLAIMER

SG Micro Corp reserves the right to make any change in circuit design, or specifications without prior notice.

PIN CONFIGURATIONS

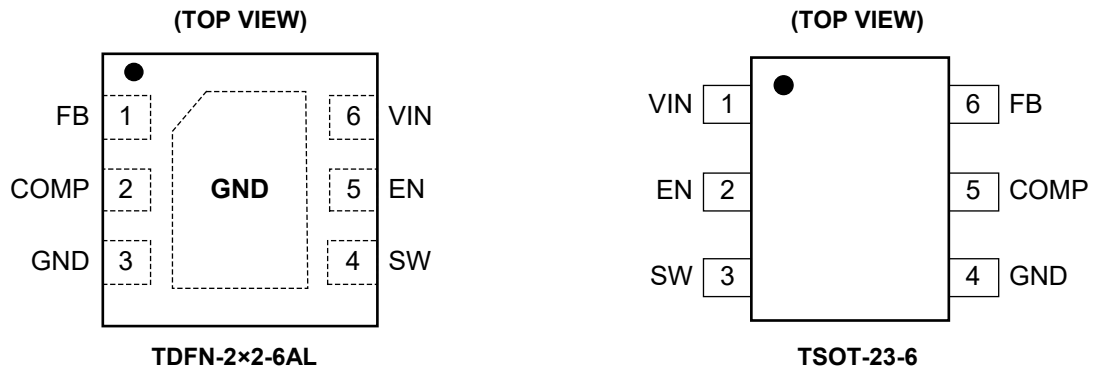

PIN DESCRIPTION

PIN		NAME	I/O	FUNCTION
TDFN-2x2-6AL	TSOT-23-6			
1	6	FB	I	Feedback Pin for Current. Connect to the center tap of a resistor divider to program the output voltage.
2	5	COMP	O	Output of the Transconductance Error Amplifier. Connect an external RC network to this pin to compensate the regulator.
3	4	GND	O	Ground.
4	3	SW	I	Switching Node of the IC. Connect SW to the switched side of the inductor.
5	2	EN	I	Enable Pin of the Boost Regulator. Logic low disables the chip. Logic high enables the chip.
6	1	VIN	I	The Input Supply Pin for the IC. Connect VIN to a supply voltage between 3V and 20V.
Exposed Pad	—	GND	—	The exposed pad should be soldered to the analog ground plane to avoid thermal issue. If possible, use thermal vias to connect to ground plane for ideal power dissipation.

ELECTRICAL CHARACTERISTICS(V_{IN} = 3.6V, V_{EN} = V_{IN}, T_J = -40°C to +85°C, typical values are at T_J = +25°C, unless otherwise noted.)

PARAMETER	SYMBOL	CONDITIONS	MIN	TYP	MAX	UNITS
Input Supply						
Input Voltage Range	V _{IN}		3		20	V
Operating Quiescent Current into VIN	I _Q	Device PWM switching no load		400	600	μA
Shutdown Current	I _{SHDN}	T _J = +25°C, V _{EN} = GND, V _{IN} = 4.2V			1	μA
Under-Voltage Lockout Threshold	UVLO	V _{IN} falling		2.2	2.5	V
Under-Voltage Lockout Hysteresis	V _{HYS}			70		mV
Enable and Reference Control						
EN Logic High Voltage	V _{IH}	V _{IN} = 3V to 20V	1.6			V
EN Logic Low Voltage	V _{IL}	V _{IN} = 3V to 20V			0.4	V
EN Pull-Down Resistor	R _{EN}	T _J = +25°C	300	500	700	kΩ
Voltage and Current Control						
Voltage Feedback Regulation Voltage	V _{REF}		1.203	1.229	1.255	V
Voltage Feedback Input Bias Current	I _{FB}	V _{FB} = 1.3V			300	nA
Oscillator Frequency	f _S		0.86	1.1	1.38	MHz
Maximum Duty Cycle	D	V _{FB} = 1.1V	90	95		%
Minimum ON Pulse Width	t _{MIN_ON}			80		ns
COMP Pin Sink Current	I _{SINK}			55		μA
COMP Pin Source Current	I _{SOURCE}			55		μA
Error Amplifier Transconductance	G _{EA}		200	300	440	μS
Power Switch						
N-Channel MOSFET On-Resistance	R _{DSON}	T _J = +25°C, V _{IN} = 3.6V		0.36	0.55	Ω
		T _J = +25°C, V _{IN} = 3.0V			0.6	
N-Channel Leakage Current	I _{LN_NFET}	T _J = +25°C, V _{SW} = 35V, V _{EN} = 0V			1	μA
Over-Current and Soft-Start						
N-Channel MOSFET Current Limit	I _{LIM}	T _J = +25°C	0.9	1.2	1.56	A
V _{REF} Ramp Up Time	t _r			2		ms
Thermal Shutdown						
Thermal Shutdown Threshold	T _{SHDN}			150		°C
Thermal Shutdown Threshold Hysteresis	T _{HYS}			15		°C

TYPICAL PERFORMANCE CHARACTERISTICS

T_J = +25°C, L = 10μH and D₁ = ONsemi MBR0540T1, unless otherwise noted.

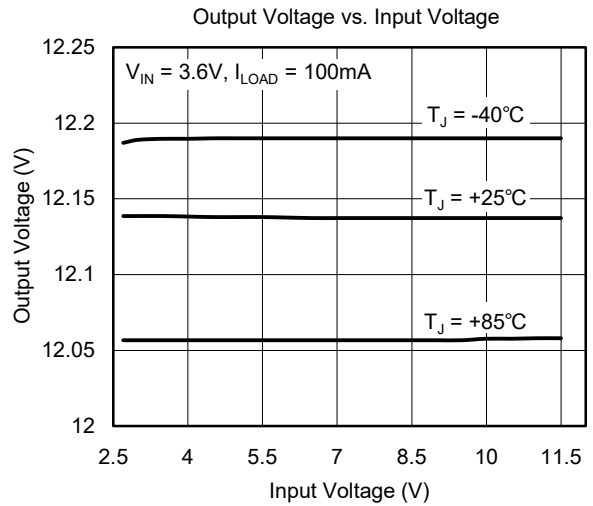
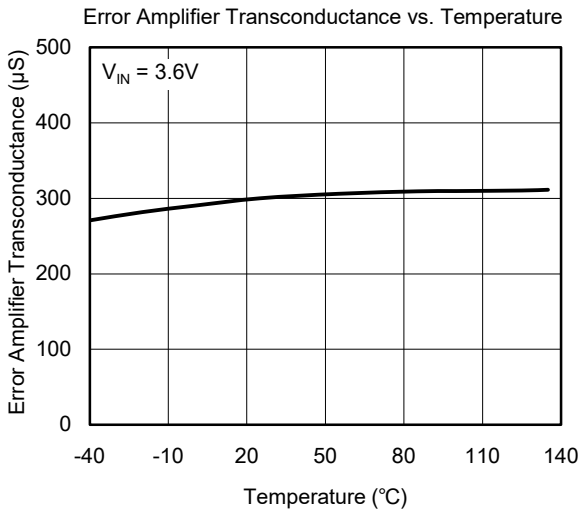
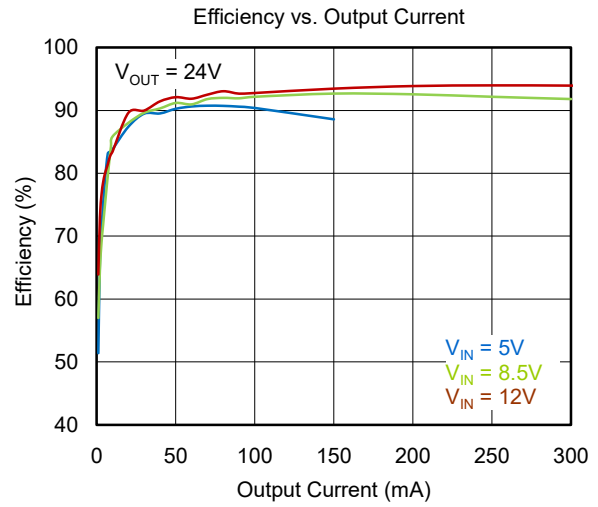
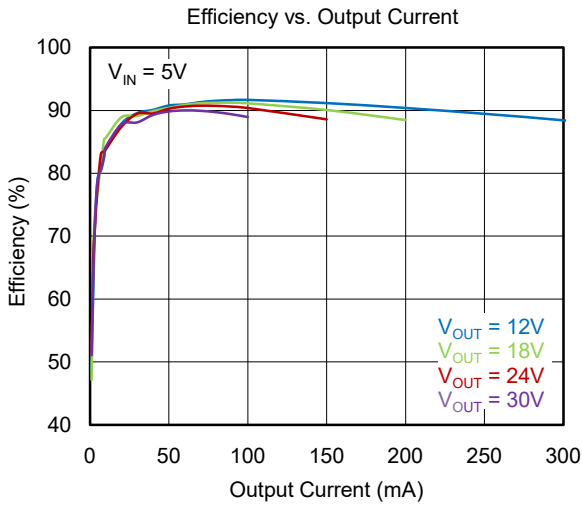

TYPICAL PERFORMANCE CHARACTERISTICS (continued)

$T_J = +25^\circ\text{C}$, $L = 10\mu\text{H}$ and $D_1 = \text{ONsemi MBR0540T1}$, unless otherwise noted.

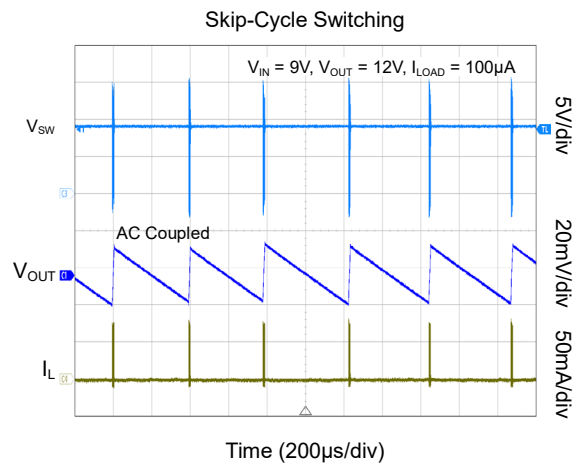
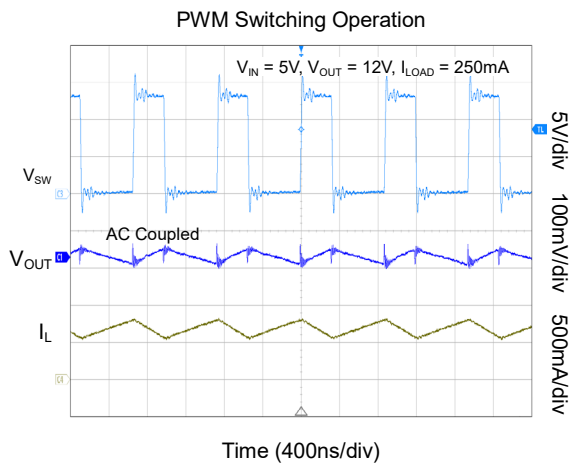
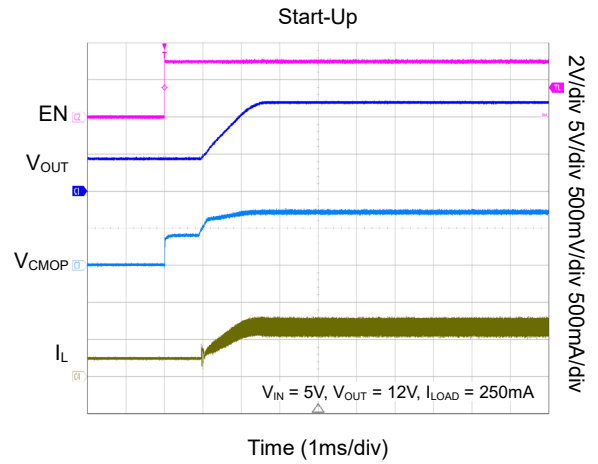
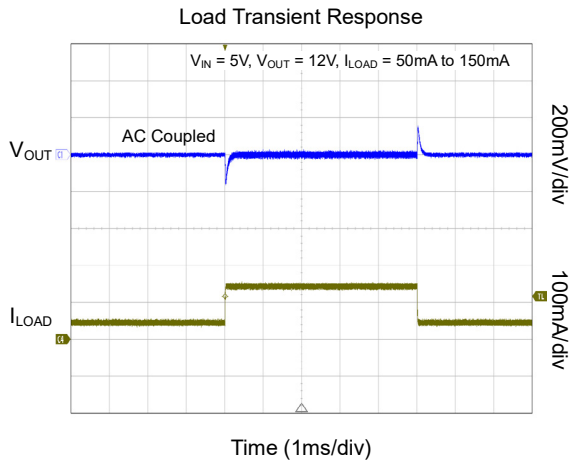

TYPICAL APPLICATION CIRCUITS

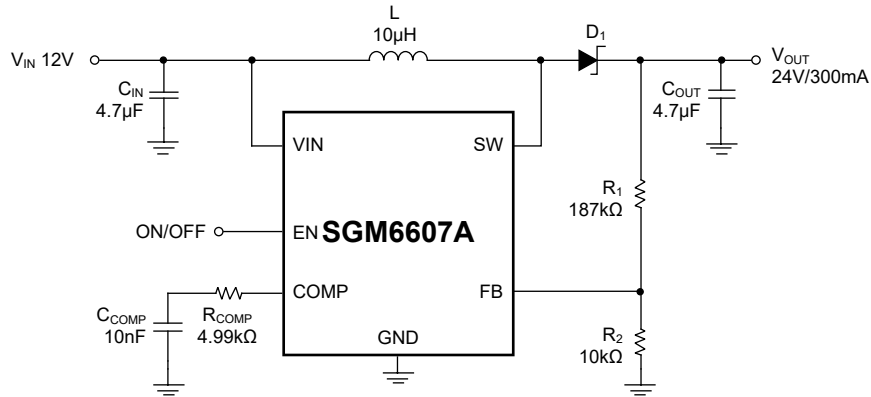

Figure 2. 12V to 24V DC/DC Power Conversion

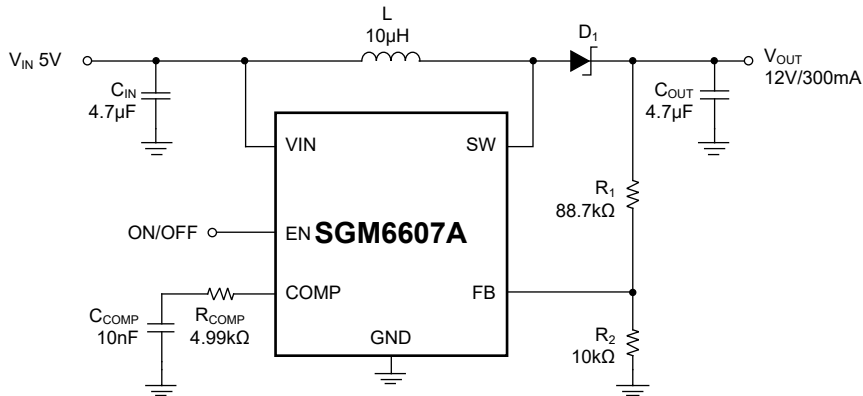

Figure 3. 5V to 12V DC/DC Power Conversion

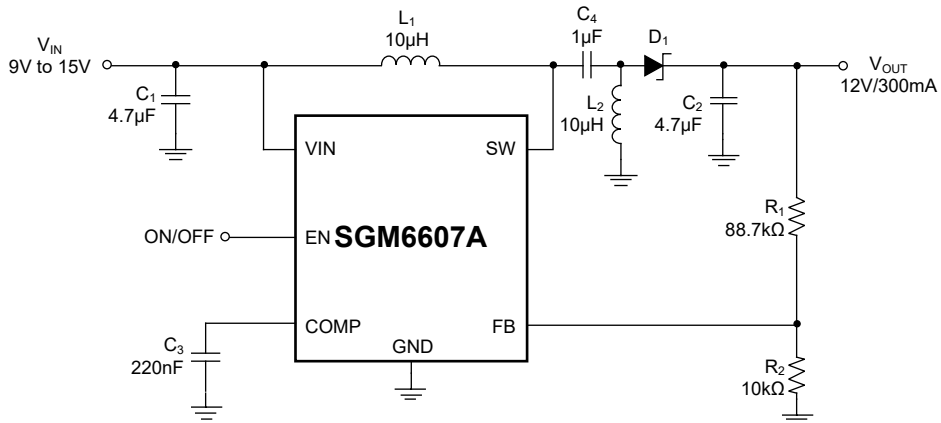

Figure 4. 12V SEPIC (Buck-Boost) Converter

FUNCTIONAL BLOCK DIAGRAM

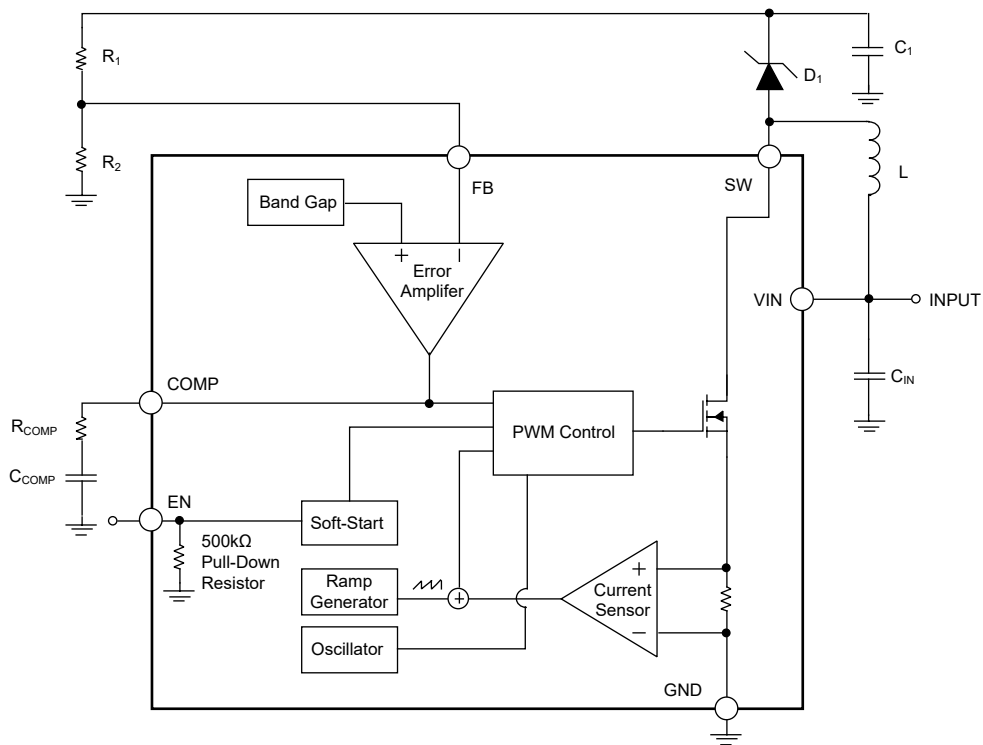

Figure 5. Functional Block Diagram

DETAILED DESCRIPTION

Operation

The SGM6607A integrates a 40V low-side FET for providing output voltages up to 38V. The device regulates the output with current mode PWM (pulse width modulation) control. The switching frequency of the PWM is fixed at 1.1MHz (TYP). The PWM control circuitry turns on the switch at the beginning of each switching cycle. The input voltage is applied across the inductor and stores the energy as the inductor current ramps up. During this portion of the switching cycle, the load current is provided by the output capacitor. When the inductor current rises to the threshold set by the error amplifier output, the power switch is turned off and the external Schottky diode is forward biased. The inductor transfers stored energy to replenish the output capacitor and supply the load current. This operation repeats each switching cycle. As shown in Figure 5, the duty cycle of the converter is determined by the PWM control comparator which compares the error amplifier output and the current signal.

A ramp signal from the oscillator is added to the current ramp. This slope compensation ramp is necessary to avoid sub-harmonic oscillations that are intrinsic to current mode control at duty cycles higher than 40%. The feedback loop regulates the FB pin to a reference voltage through an error amplifier. The output of the error amplifier must be connected to the COMP pin. An external RC compensation network must be connected to the COMP pin to optimize the feedback loop for stability and transient response.

Soft-Start

Soft-start circuitry is integrated into the IC to avoid a high inrush current during start-up. After being enabled by a logic high signal on the EN pin, the FB pin reference voltage ramps up to 1.229V in about 2ms. This ensures that the output voltage rises slowly to reduce inrush current.

Over-Current Protection

SGM6607A has a cycle-by-cycle over-current limit feature that turns off the power switch once the inductor current reaches the over-current limit. The PWM circuitry resets itself at the beginning of the next switch cycle. During an over-current event, this results in a decrease of output voltage with respect to load. The current limit threshold as well as input voltage, output voltage, switching frequency and inductor value determine the maximum available output current. Larger inductance values typically increases the current output capability because of the reduced current ripple. See the Application Information section for the output current calculation.

Under-Voltage Lockout (UVLO)

An under-voltage lockout prevents miss-operation of the device at input voltages below 2.2V (TYP). When the input voltage is below the under-voltage threshold, the device remains off and the internal switch FET is turned off. The under-voltage lockout threshold is set below minimum operating voltage of 3V to avoid any transient V_{IN} dip triggering the UVLO and causing the device to reset. For input voltages between UVLO threshold and 3V, the device attempts operation, but the performance in specification is not guaranteed.

Thermal Shutdown

An internal thermal shutdown turns off the device when the typical junction temperature of +150°C is exceeded. The IC restarts when the junction temperature drops by 15°C.

Enable and Shutdown

The SGM6607A enters shutdown when the EN pin voltage is less than 0.4V. In shutdown, the input supply current for the device is less than 1 μ A. The EN pin has an internal 500k Ω (TYP) pull-down resistor to disable the device when the pin is left unconnected.

APPLICATION INFORMATION

Program Output Voltage

To program the output voltage, select the values of R_1 and R_2 (see Figure 6) according to Equation 1.

$$V_{OUT} = 1.229V \times \left(\frac{R_1}{R_2} + 1 \right)$$

$$R_1 = R_2 \times \left(\frac{V_{OUT}}{1.229V} - 1 \right) \quad (1)$$

Considering the leakage current through the resistor divider and noise decoupling to FB pin, an optimum value for R_2 is around 10k Ω . The output voltage tolerance depends on the accuracy of the reference voltage and the tolerance of R_1 and R_2 .

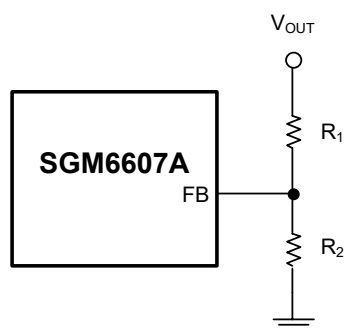

Figure 6. Program Output Voltage

Maximum Output Current

The over-current limit in a boost converter limits the maximum input current, and thus the maximum input power for a given input voltage. The maximum output power is less than the maximum input power due to power conversion losses. Therefore, the current limit setting, input voltage, output voltage and efficiency can all affect the maximum output current. The current limit clamps the peak inductor current; therefore, the ripple must be subtracted to derive the maximum DC current. The ripple current is a function of the switching frequency, inductor value and duty cycle. The following equations take into account of all the above factors for maximum output current calculation.

$$I_P = \frac{1}{\left[L \times f_S \times \left(\frac{1}{V_{OUT} + V_F - V_{IN}} + \frac{1}{V_{IN}} \right) \right]} \quad (2)$$

where:

I_P = Inductor peak-to-peak ripple current

L = Inductor value

V_F = Schottky diode forward voltage

f_S = Switching frequency

V_{OUT} = Output voltage

$$I_{OUT_MAX} = \frac{V_{IN} \times \left(I_{LIM} - \frac{I_P}{2} \right) \times \eta}{V_{OUT}} \quad (3)$$

where:

I_{OUT_MAX} = Maximum output current of the boost converter

I_{LIM} = Over-current limit

η = Efficiency

For instance, when V_{IN} is 5V, V_{OUT} is 12V, the inductor is 10 μ H, the Schottky forward voltage is 0.2V; and then the maximum output current is 300mA in a typical operation.

Switch Duty Cycle

The maximum switch duty cycle (D) of the SGM6607A is 96% (TYP). The duty cycle of a boost converter under continuous conduction mode (CCM) is given by:

$$D = \frac{V_{OUT} - V_{IN}}{V_{OUT}} \quad (4)$$

For a 5V to 12V application, the duty cycle is 58.3%, and for a 5V to 24V application, the duty cycle is 79.2%. The duty cycle must be lower than the maximum specification of 90% in the application; otherwise, the output voltage cannot be regulated.

Once the PWM switch is turned on, the SGM6607A has minimum ON pulse width. This sets the limit of the minimum duty cycle. When operating at low duty cycles, the SGM6607A enters pulse-skipping mode. In this mode, the device turns the power switch off for several switching cycles to prevent the output voltage from rising above regulation. This operation typically occurs in light load condition when the PWM operates in discontinuous mode.

APPLICATION INFORMATION (continued)

Inductor Selection

The selection of the inductor affects steady state operation as well as transient behavior and loop stability. These factors make it the most important component in power regulator design. There are three important inductor specifications: inductor value, DC resistance (DCR) and saturation current. Considering inductor value alone is not enough.

The inductance value of the inductor determines its ripple current. It is recommended that the peak-to-peak ripple current given by Equation 2 be set to 30% - 40% of the DC current. Also, the inductance values should not be beyond the range of 6.8μH to 22μH. It is a good compromise of power losses and inductor size. Inductor DC current can be calculated as:

$$I_{IN_DC} = \frac{V_{OUT} \times I_{OUT}}{V_{IN} \times \eta} \quad (5)$$

Inductor values can have ±20% tolerance with no current bias. When the inductor current approaches saturation level, its inductance can decrease 20% to 35% from the 0A value depending on how the inductor vendor defines saturation current. Using an inductor with a smaller inductance value forces discontinuous PWM where the inductor current ramps down to zero before the end of each switching cycle. This reduces the boost converter's maximum output current, causes large input voltage ripple and reduces efficiency. In general, inductors with large inductance and low DCR values provide much more output current and higher conversion efficiency. Small inductance value can give better the load transient response. For these reasons, a 6.8μH to 22μH inductance value range is recommended.

SGM6607A has built-in slope compensation to avoid sub-harmonic oscillation associated with current mode control. If the inductor value is lower than 6.8μH, the slope compensation may not be adequate, and the loop can become unstable. Therefore, care needs to be taken when the selected inductance is different from the recommended values.

External Compensation Selection

The SGM6607A has an external compensation, COMP pin, which allows the loop response to be optimized for

each application. The COMP pin is the output of the internal error amplifier. An external resistor R_{COMP} and a ceramic capacitor C_{COMP} are connected to COMP pin to provide a pole and a zero. This pole and zero, along with the inherent pole of a current mode control boost converter, determine the close loop frequency response. This is important to a converter stability and transient response.

The following equations summarize the poles, zeros and DC gain in SGM6607A, as shown in the Functional Block Diagram. They include the dominant pole (f_{P1}), the output pole (f_{P2}) of a boost converter, the right-half-plane zero (f_{RHPZ}) of a boost converter, the zero (f_Z) generated by R_{COMP} and C_{COMP} and the DC gain (A).

$$f_{P1} = \frac{1}{2\pi \times 140M\Omega \times C_{COMP}} \quad (6)$$

$$f_{P2} = \frac{2}{2\pi \times R_{OUT} \times C_{OUT}} \quad (7)$$

$$f_{RHPZ} = \frac{R_{OUT}}{2\pi \times L} \times \left(\frac{V_{IN}}{V_{OUT}} \right)^2 \quad (8)$$

$$f_Z = \frac{1}{2\pi \times R_{COMP} \times C_{COMP}} \quad (9)$$

$$A = \frac{1.229V}{V_{OUT}} \times G_{EA} \times 140M\Omega \times \frac{V_{IN}}{V_{OUT} \times R_{SENSE}} \times R_{OUT} \times \frac{1}{2} \quad (10)$$

where R_{OUT} is the load resistance, G_{EA} is the error amplifier transconductance located in the Electrical Characteristics table and R_{SENSE} (200mΩ) is a sense resistor in the current control loop. These equations help generate a simple bode plot for SGM6607A loop analysis.

Increasing R_{COMP} or reducing C_{COMP} increases the close loop bandwidth which improves the transient response. Adjusting R_{COMP} and C_{COMP} in opposite directions increase the phase, and help loop stability. For many of the applications, the recommended value of 4.99kΩ and 10nF makes an ideal compromise between transient response and loop stability. To optimize the compensation, use C_{COMP} in the range of 1nF to 22nF, and R_{COMP} of 4.99kΩ.

APPLICATION INFORMATION (continued)**Schottky Diode Selection**

The high switching frequency of the SGM6607A demands a high-speed rectification for optimum efficiency. Ensure that the average and peak current rating of the diode exceeds the average output current and peak inductor current. In addition, the diode's reverse breakdown voltage must exceed the switch FET rating voltage of 40V. However, Schottky diodes with lower rated voltages can be used for lower output voltages to save the solution size and cost. For example, a converter providing a 12V output with 20V diode is a good choice.

Input and Output Capacitors Selection

The output capacitor is mainly selected to meet the requirements for the output ripple and loop stability. The ripple voltage is related to the capacitor's capacitance and its equivalent series resistance (ESR). Assuming a capacitor with zero ESR, the minimum capacitance needed for a given ripple can be calculated using Equation 11.

$$C_{OUT} = \frac{(V_{OUT} - V_{IN}) \times I_{OUT}}{V_{OUT} \times f_S \times V_{RIPPLE}} \quad (11)$$

where, V_{RIPPLE} = peak-to-peak output ripple. The additional output ripple component caused by ESR is calculated using:

$$V_{RIPPLE_ESR} = I_{OUT} \times R_{ESR}$$

Due to its low ESR, V_{RIPPLE_ESR} can be neglected for ceramic capacitors, but must be considered if tantalum or electrolytic capacitors are used.

Care must be taken when evaluating a ceramic capacitor's de-rating under DC bias, aging and AC signal. For example, larger form factor capacitors (in 1206 size) have a resonant frequency in the range of the switching frequency. So, the effective capacitance

is significantly lower. The DC bias can also significantly reduce capacitance. Ceramic capacitors can lose as much as 50% of its capacitance at its rated voltage. Therefore, choose a ceramic capacitor with a voltage rating at least 1.5× its expected DC bias voltage.

The input capacitor in the range of 1μF to 4.7μF is recommended for input side. The output typically requires a capacitor in the range of 1μF to 10μF. The output capacitor affects the loop stability of the boost regulator. If the output capacitor is below the range, the boost regulator can potentially become unstable.

Thermal Considerations

The maximum IC junction temperature should be restricted to +150°C under normal operating conditions. This restriction limits the power dissipation of the SGM6607A. Calculate the maximum allowable dissipation, $P_{D(MAX)}$, and keep the actual dissipation less than or equal to $P_{D(MAX)}$. The maximum-power-dissipation limit is determined using Equation 12:

$$P_{D(MAX)} = \frac{150^{\circ}\text{C} - T_A}{\theta_{JA}} \quad (12)$$

where, T_A is the maximum ambient temperature for the application. θ_{JA} is the package thermal resistance.

The SGM6607A comes in TDFN and TSOT packages. Compared with the TSOT package, the TDFN package has better heat dissipation. This package includes a thermal pad that improves the thermal capabilities of the package. The θ_{JA} of the TDFN package greatly depends on the PCB layout and thermal pad connection. The thermal pad must be soldered to the analog ground on the PCB. Using thermal vias underneath the thermal pad as illustrated in the layout example.

REVISION HISTORY

NOTE: Page numbers for previous revisions may differ from page numbers in the current version.

Changes from Original (APRIL 2021) to REV.A**Page**

Changed from product preview to production data.....	All
--	-----

PACKAGE OUTLINE DIMENSIONS

TDFN-2x2-6AL

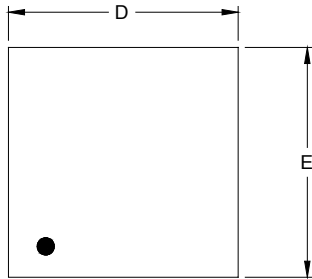

TOP VIEW

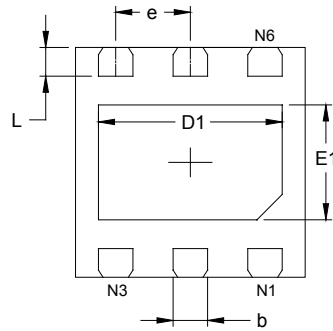

BOTTOM VIEW

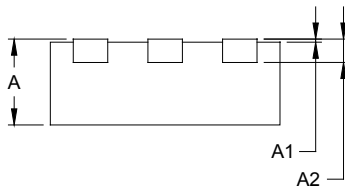

SIDE VIEW

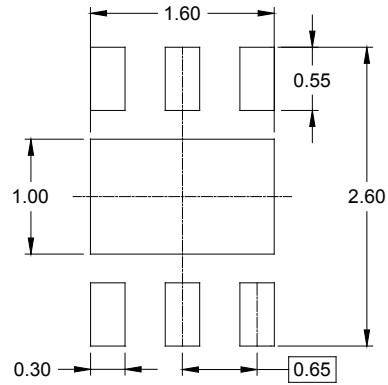

RECOMMENDED LAND PATTERN (Unit: mm)

Symbol	Dimensions In Millimeters		Dimensions In Inches	
	MIN	MAX	MIN	MAX
A	0.700	0.800	0.028	0.031
A1	0.000	0.050	0.000	0.002
A2	0.203 REF		0.008 REF	
D	1.900	2.100	0.075	0.083
D1	1.500	1.700	0.059	0.067
E	1.900	2.100	0.075	0.083
E1	0.900	1.100	0.035	0.043
b	0.250	0.350	0.010	0.014
e	0.650 BSC		0.026 BSC	
L	0.174	0.326	0.007	0.013

PACKAGE INFORMATION

PACKAGE OUTLINE DIMENSIONS

TSOT-23-6

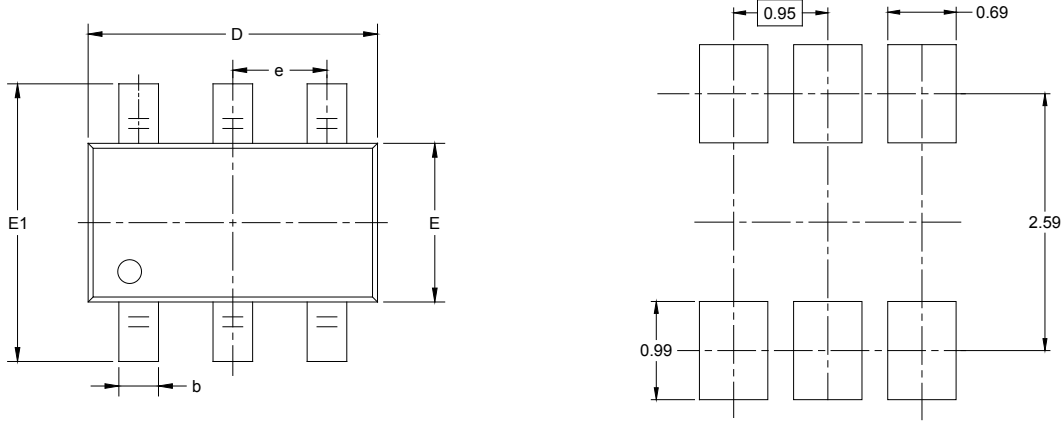

RECOMMENDED LAND PATTERN (Unit: mm)

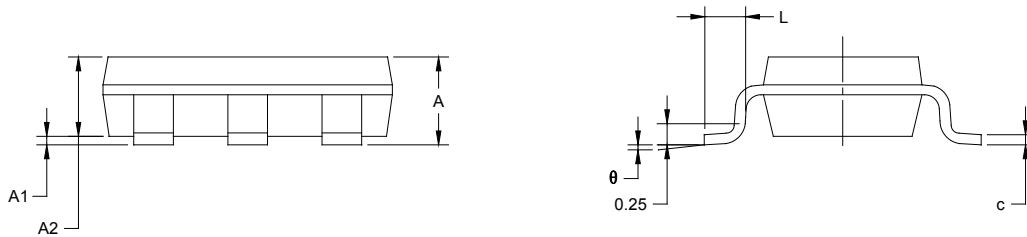

Symbol	Dimensions In Millimeters		Dimensions In Inches	
	MIN	MAX	MIN	MAX
A		1.000		0.043
A1	0.000	0.100	0.000	0.004
A2	0.700	0.900	0.028	0.039
b	0.300	0.500	0.012	0.020
c	0.080	0.200	0.003	0.008
D	2.850	2.950	0.112	0.116
E	1.550	1.650	0.061	0.065
E1	2.650	2.950	0.104	0.116
e	0.950 BSC		0.037 BSC	
L	0.300	0.600	0.012	0.024
θ	0°	8°	0°	8°

TAPE AND REEL INFORMATION

REEL DIMENSIONS



TAPE DIMENSIONS



NOTE: The picture is only for reference. Please make the object as the standard.

KEY PARAMETER LIST OF TAPE AND REEL

Package Type	Reel Diameter	Reel Width W1 (mm)	A0 (mm)	B0 (mm)	K0 (mm)	P0 (mm)	P1 (mm)	P2 (mm)	W (mm)	Pin1 Quadrant
TDFN-2×2-6AL	7"	9.5	2.30	2.30	1.10	4.0	4.0	2.0	8.0	Q2
TSOT-23-6	7"	9.5	3.20	3.10	1.10	4.0	4.0	2.0	8.0	Q3

DD0001

PACKAGE INFORMATION

CARTON BOX DIMENSIONS



NOTE: The picture is only for reference. Please make the object as the standard.

KEY PARAMETER LIST OF CARTON BOX

Reel Type	Length (mm)	Width (mm)	Height (mm)	Pizza/Carton
7" (Option)	368	227	224	8
7"	442	410	224	18

DD0002

X-ON Electronics

Largest Supplier of Electrical and Electronic Components

Click to view similar products for [Switching Controllers](#) category:

Click to view products by [SGMICRO](#) manufacturer:

Other Similar products are found below :

[NCP1218AD65R2G](#) [NCP1244BD065R2G](#) [NCP6153MNTWG](#) [NCP81101BMNTXG](#) [NCP81205MNTXG](#) [SJE6600](#) [SG3845DM](#)
[NCP4204MNTXG](#) [NCP6132AMNR2G](#) [NCP81102MNTXG](#) [NCP81206MNTXG](#) [MAX1653ESET](#) [NCP1240FD065R2G](#)
[NCP1361BABAYSNT1G](#) [NCP1230P100G](#) [NX2124CSTR](#) [NCP1366BABAYDR2G](#) [NCP81174NMNTXG](#) [NCP4308DMTTWG](#)
[NCP4308AMTTWG](#) [NCP1366AABAYDR2G](#) [NCP1251FSN65T1G](#) [NCP1246BLD065R2G](#) [NTE7233](#) [ISL69122IRAZ](#) [MB39A136PFT-G-](#)
[BND-ERE1](#) [NCP1256BSN100T1G](#) [LV5768V-A-TLM-E](#) [NCP1365BABCYDR2G](#) [NCP1365AABCYDR2G](#) [NCP1246ALD065R2G](#)
[AZ494AP-E1](#) [CR1510-10](#) [NCP4205MNTXG](#) [XC9221C093MR-G](#) [XRP6141ELTR-F](#) [RY8017](#) [LP6260SQVF](#) [LP6298QVF](#) [ISL6121LIB](#)
[ISL6225CA](#) [ISL6244HRZ](#) [ISL6268CAZ](#) [ISL6315IRZ](#) [ISL6420AIAZ-TK](#) [ISL6420AIRZ](#) [ISL6420IAZ](#) [ISL6421ERZ](#) [ISL6440IA](#)
[ISL6441IRZ-TK](#)