



SGM7SZ04

Small Logic Inverter

GENERAL DESCRIPTION

The SGM7SZ04 is a single inverter from SGMICRO's Small Logic series. The device is fabricated with advanced CMOS technology to achieve ultra-high speed with high output drive while maintaining low static power dissipation over a broad V_{CC} operating range. The device is specified to operate over the 1.65V to 5.5V V_{CC} operating range. The input and output are high impedance when V_{CC} is 0V. The input tolerates voltages up to 6V, independent of V_{CC} operating voltage.

The SGM7SZ04 is available in Green SOT-23-5, SC70-5 and UTDFN-1.45×1-6L packages. It operates over an ambient temperature range of -40°C to +85°C.

FEATURES

- **Ultra-High Speed:** $t_{PD} = 4.2\text{ns}$ (TYP) into 50pF at $V_{CC} = 3.3\text{V}$
- **High Output Drive:** $\pm 24\text{mA}$ at $V_{CC} = 3\text{V}$
- **Broad V_{CC} Operating Range:** 1.65V to 5.5V
- **Matches Performance of LCX Operated at $V_{CC} = 3.3\text{V}$**
- **Power Down High-Impedance Input/Output**
- **Over-Voltage Tolerant Input Facilitates 5V to 3V Translation**
- **Available in Green SOT-23-5, SC70-5 and UTDFN-1.45×1-6L Packages**

LOGIC SYMBOL

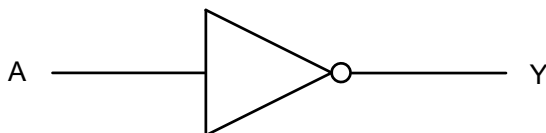

FUNCTION TABLE

INPUT	OUTPUT
A	Y
L	H
H	L

$$Y = \bar{A}$$

H = HIGH Logic Level

L = LOW Logic Level

PACKAGE/ORDERING INFORMATION

MODEL	PIN-PACKAGE	SPECIFIED TEMPERATURE RANGE	ORDERING NUMBER	PACKAGE MARKING	PACKAGE OPTION
SGM7SZ04	SC70-5	-40°C to +85°C	SGM7SZ04YC5G/TR	SF3XX	Tape and Reel, 3000
	SOT-23-5	-40°C to +85°C	SGM7SZ04YN5G/TR	SF4XX	Tape and Reel, 3000
	UTDFN-1.45x1-6L	-40°C to +85°C	SGM7SZ04YUDL6G/TR	TCX	Tape and Reel, 5000

NOTE: XX = Date Code, X = Date Code.

MARKING INFORMATION

SYX X X

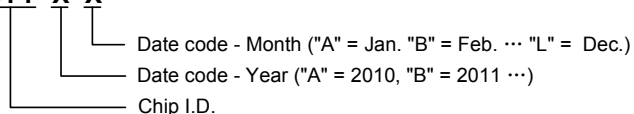

For example: SF3CC (2012, March)

ABSOLUTE MAXIMUM RATINGS

Supply Voltage, V_{CC}	-0.5V to 6.0V
DC Input Voltage, V_{IN}	-0.5V to 6.0V
DC Output Voltage, V_{OUT}	-0.5V to 6.0V
DC Input Diode Current, I_{IK} ($V_{IN} < -0.5V$).....	-50mA
DC Output Diode Current, I_{OK} ($V_{OUT} < -0.5V$).....	-50mA
DC Output Current, I_{OUT}	$\pm 50mA$
DC V_{CC} or Ground Current, I_{CC} or I_{GND}	$\pm 50mA$
Operating Temperature Range.....	-40°C to +85°C
Junction Temperature.....	150°C
Storage Temperature Range.....	-65°C to +150°C
Lead Temperature (Soldering, 10sec).....	260°C
ESD Susceptibility	
HBM	8000V
MM	400V

NOTE:

Stresses beyond those listed under "Absolute Maximum Ratings" may cause permanent damage to the device. These are stress ratings only, and functional operation of the device at these or any other conditions beyond those indicated in the operational sections of the specifications is not implied. Exposure to absolute maximum rating conditions for extended periods may affect device reliability.

CAUTION

This integrated circuit can be damaged by ESD if you don't pay attention to ESD protection. SGMICRO recommends that all integrated circuits be handled with appropriate precautions. Failure to observe proper handling and installation procedures can cause damage. ESD damage can range from subtle performance degradation to complete device failure. Precision integrated circuits may be more susceptible to damage because very small parametric changes could cause the device not to meet its published specifications.

SGMICRO reserves the right to make any change in circuit design, specification or other related things if necessary without notice at any time. Please contact SGMICRO sales office to get the latest datasheet.

PIN CONFIGURATIONS (TOP VIEW)

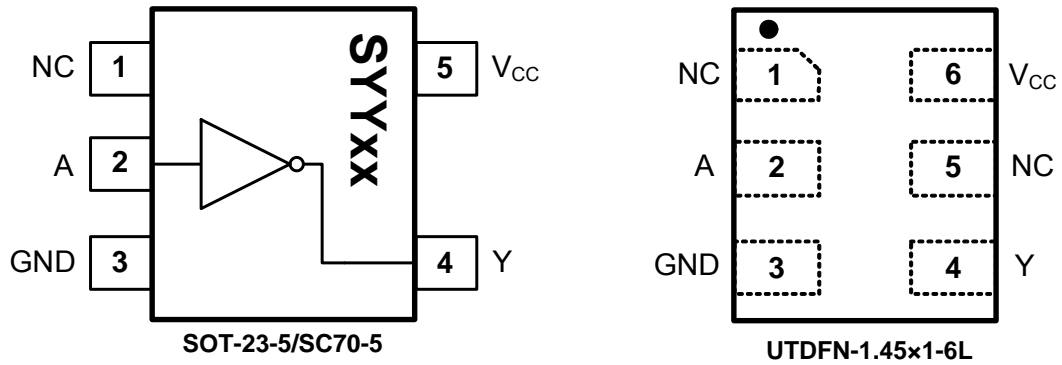

PIN DESCRIPTION

PIN		NAME	FUNCTION
SOT-23-5 SC70-5	UTDFN-1.45x1-6L		
1	1, 5	NC	No Connection.
2	2	A	Input. Unused input must be held high or low. It may not float.
3	3	GND	Ground.
4	4	Y	Output.
5	6	V _{CC}	Power Supply.

ELECTRICAL CHARACTERISTICS(T_A = -40°C to +85°C, typical values are at T_A = +25°C, unless otherwise noted.)

PARAMETER	SYMBOL	CONDITIONS	V _{CC} (V)	MIN	TYP	MAX	UNITS				
GENERAL											
Power Supply Range	V _{CC}			1.65		5.50	V				
Supply Voltage Data Retention				1.50		5.50					
Input Voltage	V _{IN}			0.00		5.50	V				
Output Voltage	V _{OUT}			0.00		V _{CC}	V				
Input Rise and Fall Times	t _r , t _f		1.8, 2.5 ± 0.2	0		20	ns/V				
			3.3 ± 0.3	0		10					
			5.0 ± 0.5	0		5					
DC PERFORMANCE											
HIGH Level Input Voltage	V _{IH}		1.65 to 5.5	0.75V _{CC}			V				
LOW Level Input Voltage	V _{IL}		1.65 to 5.5			0.25V _{CC}	V				
HIGH Level Output Voltage	V _{OH}	V _{IN} = V _{IL}	I _{OH} = -100μA	1.65	1.62	1.65	V				
				1.80	1.77	1.80					
				2.30	2.27	2.30					
				3.00	2.97	3.00					
				4.50	4.47	4.50					
			I _{OH} = -4mA	1.65	1.46	1.55					
				I _{OH} = -8mA	2.30	2.03		2.18			
				I _{OH} = -16mA	3.00	2.51		2.81			
				I _{OH} = -24mA	3.00	2.34		2.70			
I _{OH} = -32mA	4.50	4.01	4.20								
LOW Level Output Voltage	V _{OL}	V _{IN} = V _{IH}	I _{OL} = 100μA	1.65		0.00	0.02				
				1.80		0.00	0.02				
				2.30		0.00	0.02				
				3.00		0.00	0.02				
				4.50		0.00	0.02				
			I _{OL} = 4mA	1.65		0.06	0.11				
				I _{OL} = 8mA	2.30		0.09	0.17			
				I _{OL} = 16mA	3.00		0.16	0.32			
				I _{OL} = 24mA	3.00		0.24	0.49			
				I _{OL} = 32mA	4.50		0.29	0.55			
				Input Leakage Current							
				I _{IN}	V _{IN} = 5.5V, GND	0 to 5.5		±0.10	±5	μA	
				Power Off Leakage Current							
I _{OFF}	V _{IN} or V _{OUT} = 5.5V	0		0.10	5	μA					
Quiescent Supply Current											
I _{CC}	V _{IN} = 5.5V, GND	1.65 to 5.5		0.10	10	μA					

ELECTRICAL CHARACTERISTICS(Typical values are at $T_A = +25^\circ\text{C}$, unless otherwise noted.)

PARAMETER	SYMBOL	CONDITIONS	MIN	TYP	MAX	UNITS	
AC PERFORMANCE							
Propagation Delay	t_{PHL}, t_{PLH}	$V_{CC} = 1.65\text{V}$	$C_L = 15\text{pF},$ $R_L = 1\text{M}\Omega,$ Figure 1, Figure 2		9.6		ns
		$V_{CC} = 1.80\text{V}$			7.9		
		$V_{CC} = 2.50\text{V} \pm 0.20\text{V}$			4.9		
		$V_{CC} = 3.30\text{V} \pm 0.30\text{V}$			3.7		
		$V_{CC} = 5.00\text{V} \pm 0.50\text{V}$			2.8		
		$V_{CC} = 3.30\text{V} \pm 0.30\text{V}$		$C_L = 50\text{pF},$ $R_L = 500\Omega,$ Figure 1, Figure 2		4.2	
		$V_{CC} = 5.00\text{V} \pm 0.50\text{V}$			3.2		
Input Capacitance	C_{IN}	$V_{CC} = 0\text{V}$		4.0		pF	
Power Dissipation Capacitance ⁽²⁾	C_{PD}	$V_{CC} = 3.30\text{V}$	Figure 3		16.0		pF
		$V_{CC} = 5.00\text{V}$			19.0		

NOTES:

- Unused input must be held HIGH or LOW. It may not float.
- C_{PD} is defined as the value of the internal equivalent capacitance which is derived from dynamic operating current consumption (I_{CCD}) at no output loading and operating at 50% duty cycle (see Figure 3). C_{PD} is related to dynamic operating current I_{CCD} by the expression: $I_{CCD} = (C_{PD})(V_{CC})(f_{IN}) + (I_{CC,Static})$.

TEST CIRCUITS

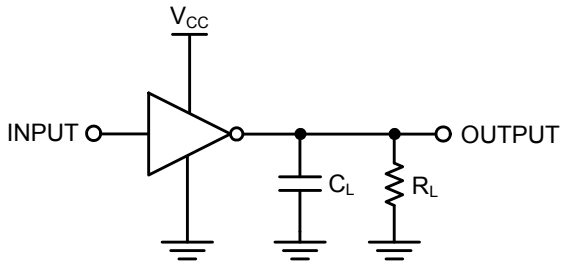

C_L includes load and stray capacitance;
 Input PRR = 1.0MHz; t_w = 500ns.

Figure 1. AC Test Circuit

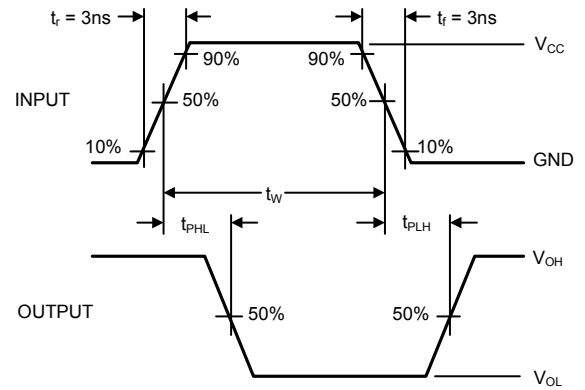
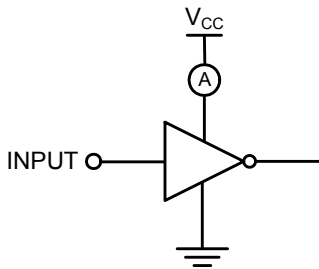

Figure 2. AC Waveforms



Input = AC Waveform; $t_r = t_f = 1.8$ ns;
 PRR = 10MHz; Duty Cycle = 50%.

Figure 3. I_{CCD} Test Circuit

PACKAGE OUTLINE DIMENSIONS

SC70-5

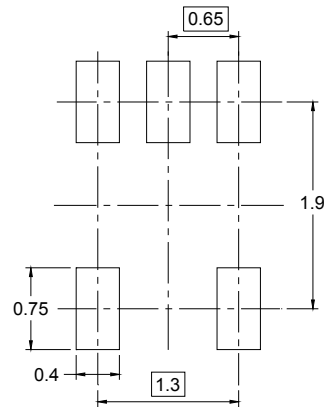
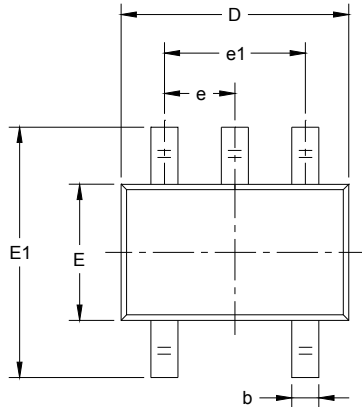

RECOMMENDED LAND PATTERN (Unit: mm)

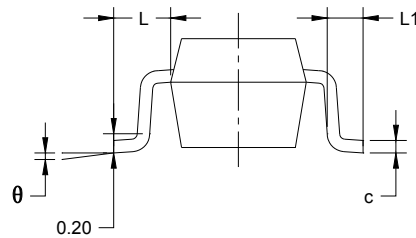
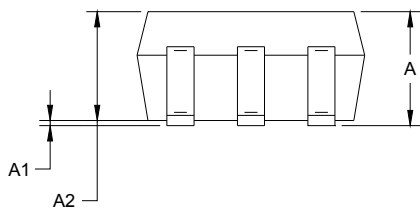

Symbol	Dimensions In Millimeters		Dimensions In Inches	
	MIN	MAX	MIN	MAX
A	0.900	1.100	0.035	0.043
A1	0.000	0.100	0.000	0.004
A2	0.900	1.000	0.035	0.039
b	0.150	0.350	0.006	0.014
c	0.080	0.150	0.003	0.006
D	2.000	2.200	0.079	0.087
E	1.150	1.350	0.045	0.053
E1	2.150	2.450	0.085	0.096
e	0.65 TYP		0.026 TYP	
e1	1.300 BSC		0.051 BSC	
L	0.525 REF		0.021 REF	
L1	0.260	0.460	0.010	0.018
θ	0°	8°	0°	8°

PACKAGE OUTLINE DIMENSIONS

SOT-23-5

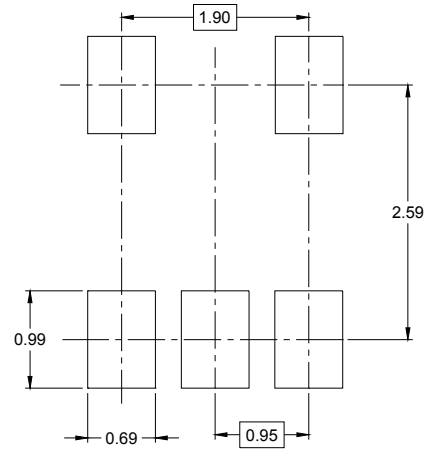
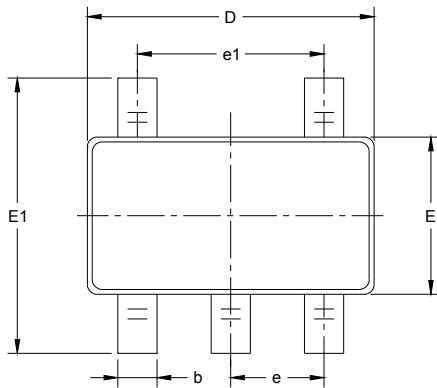

RECOMMENDED LAND PATTERN (Unit: mm)

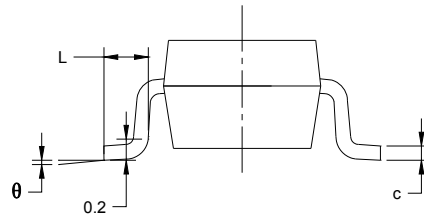
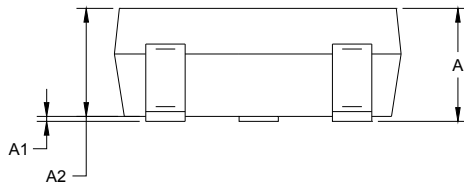

Symbol	Dimensions In Millimeters		Dimensions In Inches	
	MIN	MAX	MIN	MAX
A	1.050	1.250	0.041	0.049
A1	0.000	0.100	0.000	0.004
A2	1.050	1.150	0.041	0.045
b	0.300	0.500	0.012	0.020
c	0.100	0.200	0.004	0.008
D	2.820	3.020	0.111	0.119
E	1.500	1.700	0.059	0.067
E1	2.650	2.950	0.104	0.116
e	0.950 BSC		0.037 BSC	
e1	1.900 BSC		0.075 BSC	
L	0.300	0.600	0.012	0.024
θ	0°	8°	0°	8°

PACKAGE OUTLINE DIMENSIONS

UTDFN-1.45x1-6L

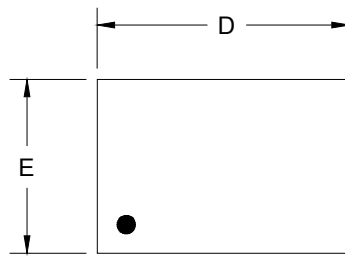

TOP VIEW

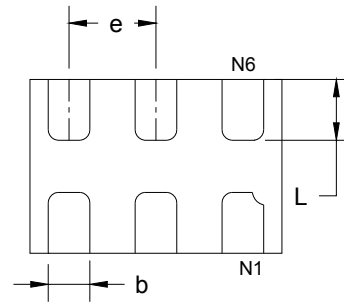

BOTTOM VIEW

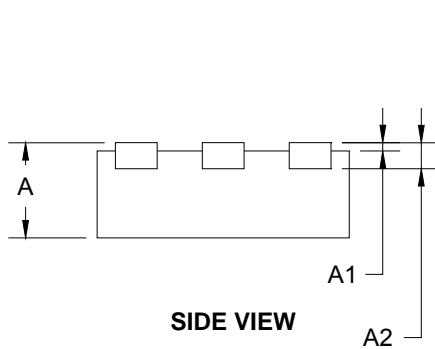

SIDE VIEW

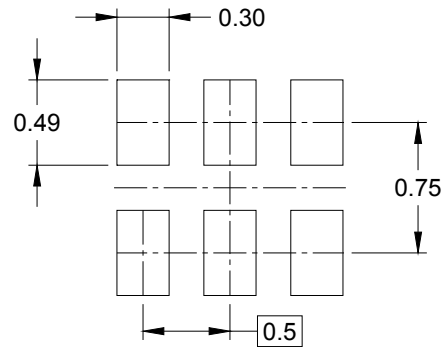

RECOMMENDED LAND PATTERN (Unit: mm)

Symbol	Dimensions In Millimeters		Dimensions In Inches	
	MIN	MAX	MIN	MAX
A	0.450	0.550	0.018	0.022
A1	0.000	0.050	0.000	0.002
A2	0.150 REF		0.006 REF	
D	1.374	1.526	0.054	0.060
E	0.924	1.076	0.036	0.042
b	0.180	0.300	0.007	0.012
e	0.500 TYP		0.020 TYP	
L	0.274	0.426	0.011	0.017

TAPE AND REEL INFORMATION

REEL DIMENSIONS

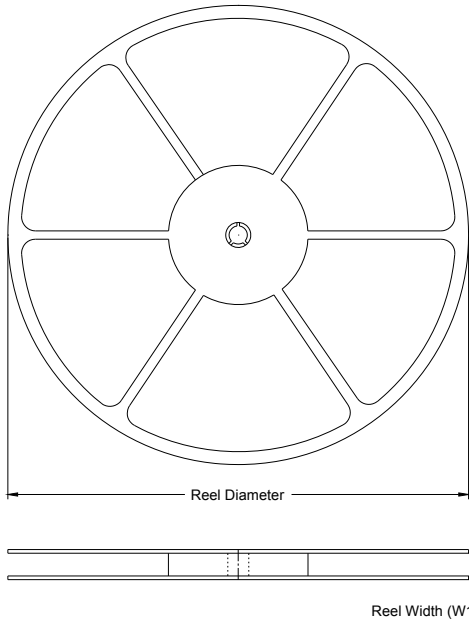

TAPE DIMENSIONS

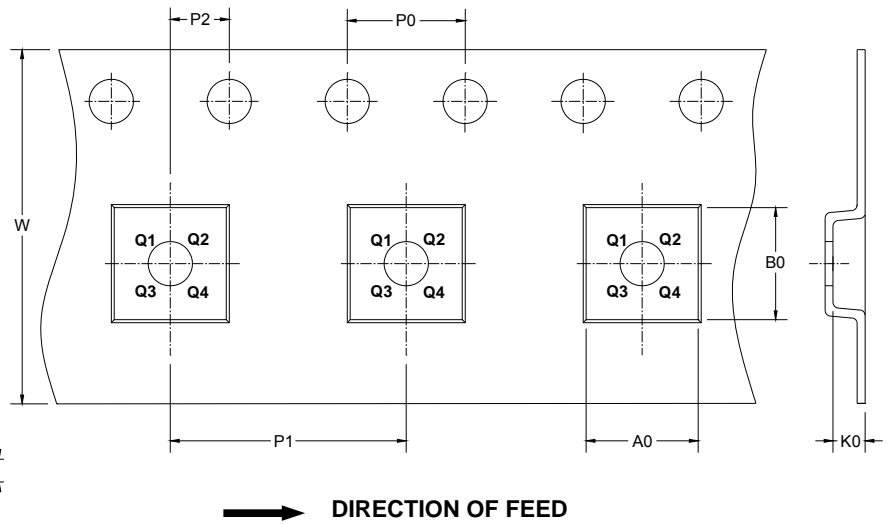

NOTE: The picture is only for reference. Please make the object as the standard.

KEY PARAMETER LIST OF TAPE AND REEL

Package Type	Reel Diameter	Reel Width W1 (mm)	A0 (mm)	B0 (mm)	K0 (mm)	P0 (mm)	P1 (mm)	P2 (mm)	W (mm)	Pin1 Quadrant
SOT-23-5	7"	9.5	3.2	3.2	1.4	4.0	4.0	2.0	8.0	Q3
SC70-5	7"	9.5	2.25	2.55	1.20	4.0	4.0	2.0	8.0	Q3
UTDFN-1.45×1-6L	7"	9.5	1.15	1.6	0.75	4.00	4.00	2.00	8.00	Q1

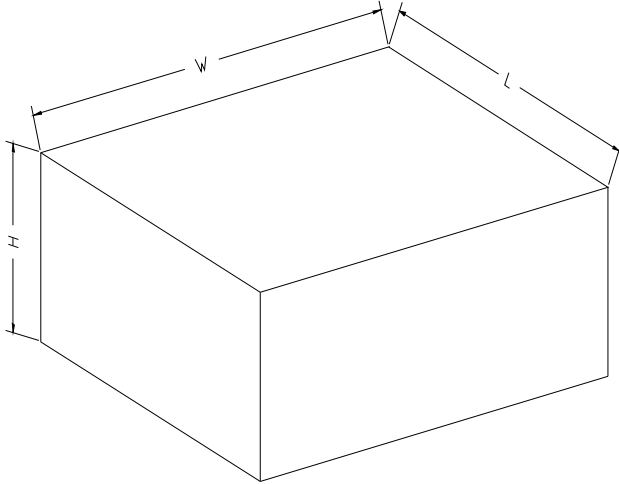
CARTON BOX DIMENSIONS

NOTE: The picture is only for reference. Please make the object as the standard.

KEY PARAMETER LIST OF CARTON BOX

Reel Type	Length (mm)	Width (mm)	Height (mm)	Pizza/Carton
7" (Option)	368	227	224	8
7"	442	410	224	18

X-ON Electronics

Largest Supplier of Electrical and Electronic Components

Click to view similar products for [Inverters](#) category:

Click to view products by [SGMICRO](#) manufacturer:

Other Similar products are found below :

[5962-8550101CA](#) [E5-652Z](#) [NL17SGU04P5T5G](#) [NLX2G04BMX1TCG](#) [412327H](#) [022413E](#) [NL17SG14AMUTCG](#) [NLU2G04AMUTCG](#)
[NLU2GU04BMX1TCG](#) [NLV14049UBDR2G](#) [NLV14069UBDTR2G](#) [NLV17SZ14DFT2G](#) [NLVVHC1G05DFT2G](#) [74LVC2G17FW4-7](#)
[NLU2G04CMX1TCG](#) [NLV17SZ06DFT2G](#) [NLV27WZ04DFT2G](#) [NLV74HCT14ADTR2G](#) [NLX2G14CMUTCG](#) [NLU1G04AMX1TCG](#)
[SNJ54ACT14W](#) [SNJ54AC04W](#) [NCV1729SN35T1G](#) [TC74VHC04FK\(EL,K\)](#) [NLV74HC04ADTR2G](#) [NLV17SZ04DFT2G](#) [74AUP2G04FW3-](#)
[7](#) [NLU1G04AMUTCG](#) [NLX2G04CMUTCG](#) [NLX2G04AMUTCG](#) [NLV74ACT00DR2G](#) [NLV74AC14DR2G](#) [NLV37WZ14USG](#)
[NLV27WZ04DFT1G](#) [NLV14106BDG](#) [NLU1GU04CMUTCG](#) [NLU1GT14AMUTCG](#) [NLU1G04CMUTCG](#) [NL17SZU04P5T5G](#)
[NL17SG14DFT2G](#) [74LVC06ADTR2G](#) [74LVC04ADR2G](#) [TC7SZ04AFS,L3J](#) [NLU1GT04AMUTCG](#) [NLV37WZ04USG](#)
[NLX3G14FMUTCG](#) [NL17SZ04P5T5G](#) [NL17SG14P5T5G](#) [NLV27WZU04DFT2G](#) [LV0008G100-4EOFN](#)