

GENERAL DESCRIPTION

The SGM7SZ125 is a single buffer with three-state output from SGMICRO's Small Logic series. The device is fabricated with advanced CMOS technology to achieve ultra-high speed with high output drive while maintaining low static power dissipation over a very broad V_{CC} operating range. The device is specified to operate over the 1.65V to 5.5V V_{CC} operating range. The inputs and output are high impedance when V_{CC} is 0V. Inputs tolerate voltages up to 6V, independent of V_{CC} operating voltage. The output tolerates voltages above V_{CC} when in the 3-state condition.

The SGM7SZ125 is available in Green SOT-23-5 and SC70-5 packages. It operates over an ambient temperature range of -40°C to +85°C.

LOGIC SYMBOL

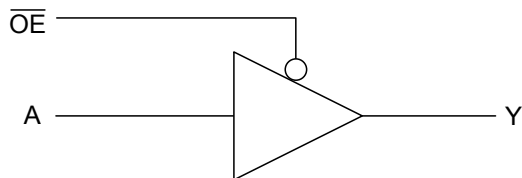

FEATURES

- **Ultra-High Speed:** $t_{PD} = 3.5ns$ (TYP) into 50pF at $V_{CC} = 3.3V$
- **High Output Drive:** $\pm 24mA$ at $V_{CC} = 3V$
- **Broad V_{CC} Operating Range:** 1.65V to 5.5V
- **Matches Performance of LCX Operated at $V_{CC} = 3.3V$**
- **Power Down High-Impedance Inputs/Output**
- **Over-Voltage Tolerant Inputs Facilitate 5V to 3V Translation**
- **Available in Green SOT-23-5 and SC70-5 Packages**

FUNCTION TABLE

INPUTS		OUTPUT
\overline{OE}	A	Y
L	L	L
L	H	H
H	X	Z

H = HIGH Logic Level
 L = LOW Logic Level
 X = Don't Care
 Z = HIGH Impedance State

PACKAGE/ORDERING INFORMATION

MODEL	PACKAGE DESCRIPTION	SPECIFIED TEMPERATURE RANGE	ORDERING NUMBER	PACKAGE MARKING	PACKING OPTION
SGM7SZ125	SC70-5	-40°C to +85°C	SGM7SZ125YC5G/TR	SFEXX	Tape and Reel, 3000
	SOT-23-5	-40°C to +85°C	SGM7SZ125YN5G/TR	SFFXX	Tape and Reel, 3000

NOTE: XX = Date Code.

Green (RoHS & HSF): SG Micro Corp defines "Green" to mean Pb-Free (RoHS compatible) and free of halogen substances. If you have additional comments or questions, please contact your SGMICRO representative directly.

MARKING INFORMATION

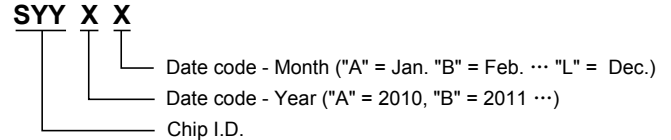

For example: SFFCC (2012, March)

ABSOLUTE MAXIMUM RATINGS

Supply Voltage, V_{CC}	-0.5V to 6.0V
DC Input Voltage, V_{IN}	-0.5V to 6.0V
DC Output Voltage, V_{OUT}	-0.5V to 6.0V
DC Input Diode Current, I_{IK} ($V_{IN} < -0.5V$)	-50mA
DC Output Diode Current, I_{OK} ($V_{OUT} < -0.5V$)	-50mA
DC Output Current, I_{OUT}	$\pm 50mA$
DC V_{CC} or Ground Current, I_{CC} or I_{GND}	$\pm 50mA$
Junction Temperature	+150°C
Storage Temperature Range	-65°C to +150°C
Lead Temperature (Soldering, 10sec)	+260°C
ESD Susceptibility	
HBM	8000V
MM	400V

RECOMMENDED OPERATING CONDITIONS

Operating Temperature Range	-40°C to +85°C
-----------------------------------	----------------

OVERSTRESS CAUTION

Stresses beyond those listed may cause permanent damage to the device. Functional operation of the device at these or any other conditions beyond those indicated in the operational section of the specification is not implied. Exposure to absolute maximum rating conditions for extended periods may affect reliability.

ESD SENSITIVITY CAUTION

This integrated circuit can be damaged by ESD if you don't pay attention to ESD protection. SGMICRO recommends that all integrated circuits be handled with appropriate precautions. Failure to observe proper handling and installation procedures can cause damage. ESD damage can range from subtle performance degradation to complete device failure. Precision integrated circuits may be more susceptible to damage because very small parametric changes could cause the device not to meet its published specifications.

DISCLAIMER

SG Micro Corp reserves the right to make any change in circuit design, specification or other related things if necessary without notice at any time.

PIN CONFIGURATIONS

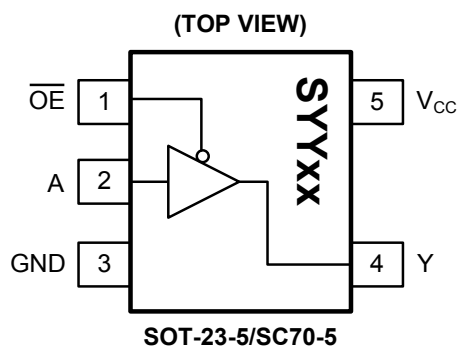

PIN DESCRIPTION

PIN	NAME	FUNCTION
1	$\overline{\text{OE}}$	Input. Unused input must be held high or low. It may not float.
2	A	Input. Unused input must be held high or low. It may not float.
3	GND	Ground.
4	Y	Output.
5	V _{CC}	Power Supply.

ELECTRICAL CHARACTERISTICS

(T_A = -40°C to +85°C, typical values are at T_A = +25°C, unless otherwise noted.)

PARAMETER	SYMBOL	CONDITIONS	V _{CC} (V)	MIN	TYP	MAX	UNITS
GENERAL							
Power Supply Range	V _{CC}			1.65		5.50	V
Supply Voltage Data Retention				1.50		5.50	V
Input Voltage	V _{IN}			0.00		5.50	V
Output Voltage	V _{OUT}	Active State		0.00		V _{CC}	V
		Three-State		0.00		5.50	
Input Rise and Fall Times	t _r , t _f		1.8, 2.5 ± 0.2	0		20	ns/V
			3.3 ± 0.3	0		10	
			5.0 ± 0.5	0		5	
DC PERFORMANCE							
HIGH Level Input Voltage	V _{IH}		1.65 to 5.5	0.75V _{CC}			V
LOW Level Input Voltage	V _{IL}		1.65 to 5.5			0.25V _{CC}	V
HIGH Level Output Voltage	V _{OH}	V _{IN} = V _{IH}	I _{OH} = -100μA	1.65	1.62	1.65	V
				1.80	1.77	1.80	
				2.30	2.27	2.30	
				3.00	2.97	3.00	
			4.50	4.47	4.50		
			I _{OH} = -4mA	1.65	1.46	1.55	
			I _{OH} = -8mA	2.30	2.03	2.18	
			I _{OH} = -16mA	3.00	2.51	2.81	
			I _{OH} = -24mA	3.00	2.34	2.70	
I _{OH} = -32mA	4.50	4.01	4.20				
LOW Level Output Voltage	V _{OL}	V _{IN} = V _{IL}	I _{OL} = 100μA	1.65		0.00	0.02
				1.80		0.00	0.02
				2.30		0.00	0.02
				3.00		0.00	0.02
			4.50		0.00	0.02	
			I _{OL} = 4mA	1.65		0.06	0.11
			I _{OL} = 8mA	2.30		0.09	0.17
			I _{OL} = 16mA	3.00		0.16	0.32
			I _{OL} = 24mA	3.00		0.24	0.49
			I _{OL} = 32mA	4.50		0.29	0.55
Input Leakage Current	I _{IN}	V _{IN} = 5.5V, GND	0 to 5.5		±0.10	±5	μA
3-STATE Output Leakage	I _{OZ}	V _{IN} = V _{IH} or V _{IL} , 0V ≤ V _{OUT} ≤ 5V	0 to 5.5		0.10	±5	μA
Power Off Leakage Current	I _{OFF}	V _{IN} or V _{OUT} = 5.5V	0		0.10	5	μA
Quiescent Supply Current	I _{CC}	V _{IN} = 5.5V, GND	1.65 to 5.5		0.10	10	μA

ELECTRICAL CHARACTERISTICS (continued)(T_A = -40°C to +85°C, typical values are at T_A = +25°C, unless otherwise noted.)

PARAMETER	SYMBOL	CONDITIONS		MIN	TYP	MAX	UNITS
AC PERFORMANCE							
Propagation Delay	t _{PHL} , t _{PLH}	V _{CC} = 1.65V	C _L = 15pF, R _D = 1MΩ, S ₁ = OPEN, Figure 1, Figure 2		8.7		ns
		V _{CC} = 1.80V			7.0		
		V _{CC} = 2.50V ± 0.20V			4.0		
		V _{CC} = 3.30V ± 0.30V			3.0		
		V _{CC} = 5.00V ± 0.50V			2.3		
		V _{CC} = 3.30V ± 0.30V		C _L = 50pF, R _D = 500Ω, S ₁ = OPEN, Figure 1, Figure 2		3.5	
V _{CC} = 5.00V ± 0.50V		2.6					
Output Enable Time	t _{PZL} , t _{PZH}	V _{CC} = 1.65V	C _L = 50pF, R _D = 500Ω, R _U = 500Ω, S ₁ = GND for t _{PZH} , S ₁ = V _{IN} for t _{PZL} , V _{IN} = 2V _{CC} , Figure 1, Figure 2		9.6		ns
		V _{CC} = 1.80V			8.2		
		V _{CC} = 2.50V ± 0.20V			5.5		
		V _{CC} = 3.30V ± 0.30V			4.6		
		V _{CC} = 5.00V ± 0.50V			4.0		
Output Disable Time	t _{PLZ} , t _{PHZ}	V _{CC} = 1.65V	C _L = 50pF, R _D = 500Ω, R _U = 500Ω, S ₁ = GND for t _{PHZ} , S ₁ = V _{IN} for t _{PLZ} , V _{IN} = 2V _{CC} , Figure 1, Figure 2		9.7		ns
		V _{CC} = 1.80V			8.1		
		V _{CC} = 2.50V ± 0.20V			3.9		
		V _{CC} = 3.30V ± 0.30V			3.0		
		V _{CC} = 5.00V ± 0.50V			2.4		
Input Capacitance	C _{IN}	V _{CC} = 0V			4.0		pF
Output Capacitance	C _{OUT}	V _{CC} = 0V			6.0		pF
Power Dissipation Capacitance ⁽²⁾	C _{PD}	V _{CC} = 3.30V	Figure 3		15.0		pF
		V _{CC} = 5.00V			17.0		

NOTES:

- Unused inputs must be held HIGH or LOW. They may not float.
- C_{PD} is defined as the value of the internal equivalent capacitance which is derived from dynamic operating current consumption (I_{CCD}) at no output loading and operating at 50% duty cycle (see Figure 3). C_{PD} is related to dynamic operating current I_{CCD} by the expression: I_{CCD} = (C_{PD}) (V_{CC}) (f_{IN}) + (I_{CC,Static}).

TEST CIRCUITS

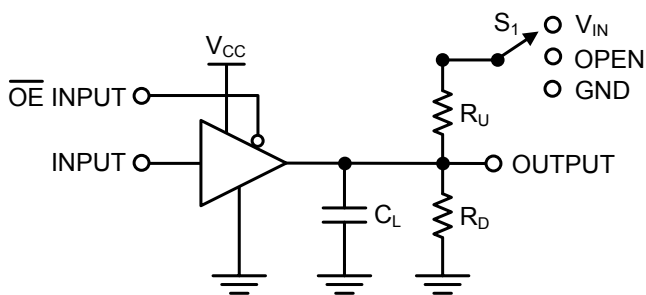

C_L includes load and stray capacitance;
Input PRR = 1.0MHz; t_w = 500ns.

Figure 1. AC Test Circuit

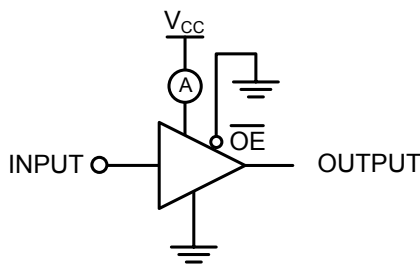

Input = AC Waveform; $t_r = t_f = 1.8$ ns;
PRR = 10MHz; Duty Cycle = 50%.

Figure 3. I_{CCD} Test Circuit

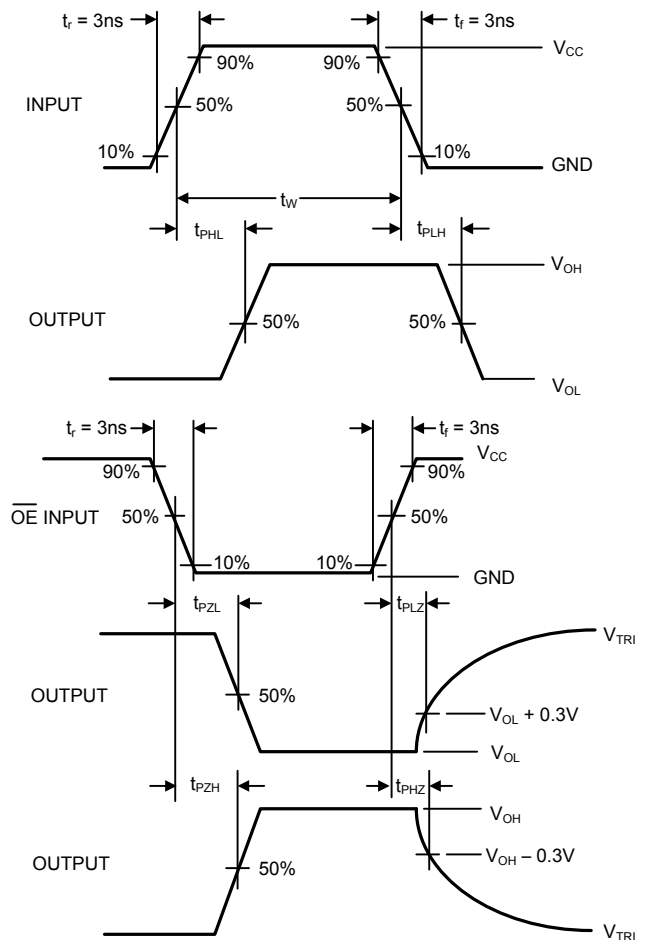

Figure 2. AC Waveforms

REVISION HISTORY

NOTE: Page numbers for previous revisions may differ from page numbers in the current version.

Changes from Original (OCTOBER 2013) to REV.A

Changed from product preview to production data.....	All
--	-----

PACKAGE OUTLINE DIMENSIONS

SOT-23-5

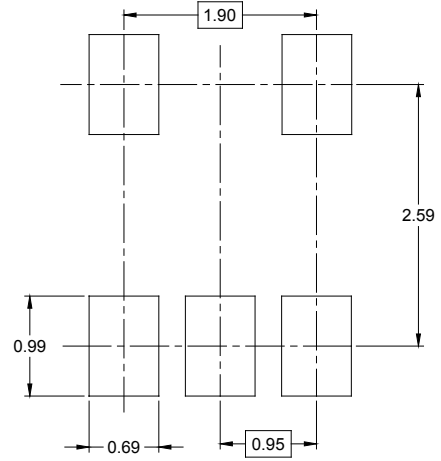
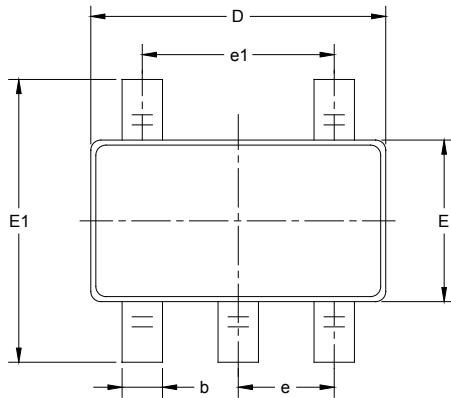

RECOMMENDED LAND PATTERN (Unit: mm)

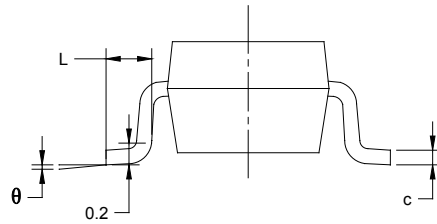
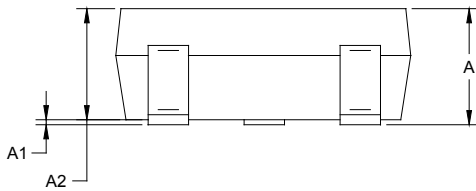

Symbol	Dimensions In Millimeters		Dimensions In Inches	
	MIN	MAX	MIN	MAX
A	1.050	1.250	0.041	0.049
A1	0.000	0.100	0.000	0.004
A2	1.050	1.150	0.041	0.045
b	0.300	0.500	0.012	0.020
c	0.100	0.200	0.004	0.008
D	2.820	3.020	0.111	0.119
E	1.500	1.700	0.059	0.067
E1	2.650	2.950	0.104	0.116
e	0.950 BSC		0.037 BSC	
e1	1.900 BSC		0.075 BSC	
L	0.300	0.600	0.012	0.024
θ	0°	8°	0°	8°

PACKAGE OUTLINE DIMENSIONS

SC70-5

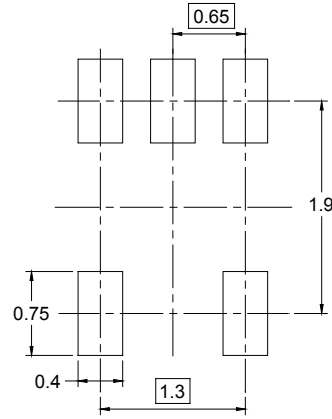
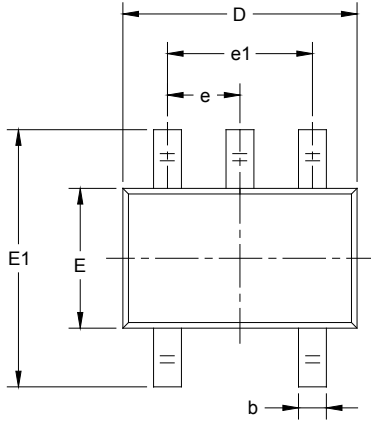

RECOMMENDED LAND PATTERN (Unit: mm)

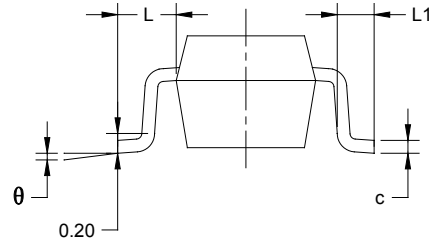
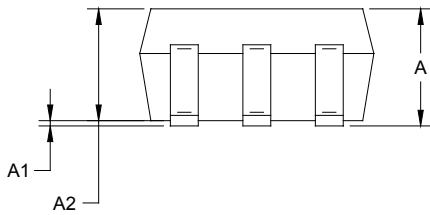

Symbol	Dimensions In Millimeters		Dimensions In Inches	
	MIN	MAX	MIN	MAX
A	0.900	1.100	0.035	0.043
A1	0.000	0.100	0.000	0.004
A2	0.900	1.000	0.035	0.039
b	0.150	0.350	0.006	0.014
c	0.080	0.150	0.003	0.006
D	2.000	2.200	0.079	0.087
E	1.150	1.350	0.045	0.053
E1	2.150	2.450	0.085	0.096
e	0.65 TYP		0.026 TYP	
e1	1.300 BSC		0.051 BSC	
L	0.525 REF		0.021 REF	
L1	0.260	0.460	0.010	0.018
θ	0°	8°	0°	8°

TAPE AND REEL INFORMATION

REEL DIMENSIONS

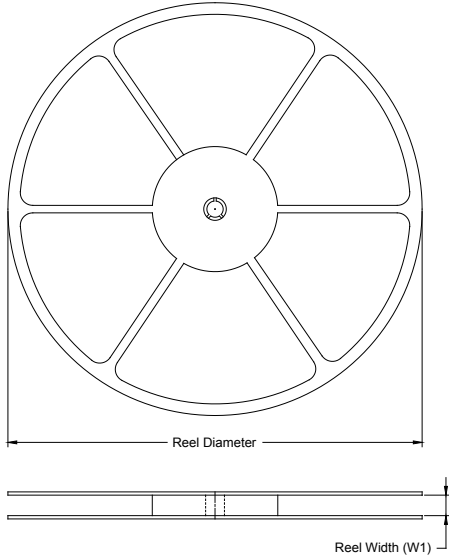

TAPE DIMENSIONS

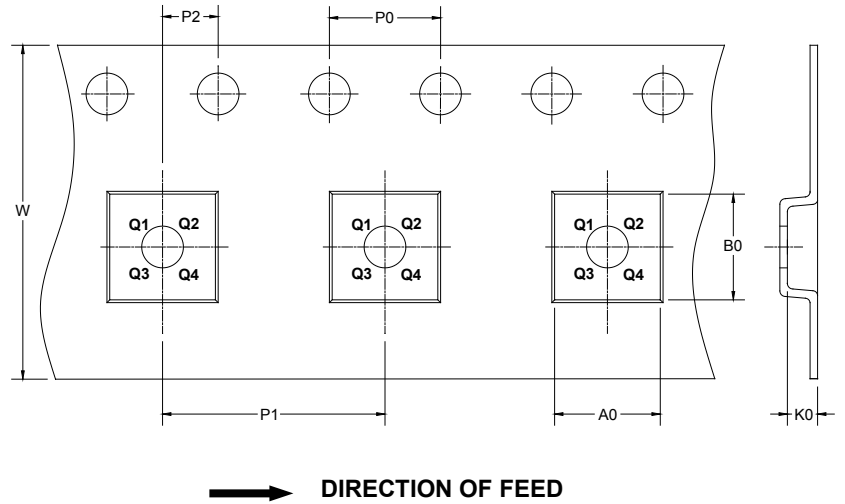

NOTE: The picture is only for reference. Please make the object as the standard.

KEY PARAMETER LIST OF TAPE AND REEL

Package Type	Reel Diameter	Reel Width W1 (mm)	A0 (mm)	B0 (mm)	K0 (mm)	P0 (mm)	P1 (mm)	P2 (mm)	W (mm)	Pin1 Quadrant
SOT-23-5	7"	9.5	3.20	3.20	1.40	4.0	4.0	2.0	8.0	Q3
SC70-5	7"	9.5	2.25	2.55	1.20	4.0	4.0	2.0	8.0	Q3

DD0001

PACKAGE INFORMATION

CARTON BOX DIMENSIONS



NOTE: The picture is only for reference. Please make the object as the standard.

KEY PARAMETER LIST OF CARTON BOX

Reel Type	Length (mm)	Width (mm)	Height (mm)	Pizza/Carton
7" (Option)	368	227	224	8
7"	442	410	224	18

DD0002

X-ON Electronics

Largest Supplier of Electrical and Electronic Components

Click to view similar products for [Logic Gates](#) category:

Click to view products by [SGMICRO](#) manufacturer:

Other Similar products are found below :

[74HC85N](#) [NL17SG32DFT2G](#) [CD4068BE](#) [NL17SG86DFT2G](#) [NLV14001UBDR2G](#) [NLX1G11AMUTCG](#) [NLX1G97MUTCG](#) [74LS38](#)
[74LVC1G08Z-7](#) [74LVC32ADTR2G](#) [CD4025BE](#) [MC74HCT20ADTR2G](#) [NLV17SZ00DFT2G](#) [NLV17SZ126DFT2G](#) [NLV27WZ17DFT2G](#)
[NLV74HC02ADR2G](#) [74HC32S14-13](#) [74LS133](#) [74LVC1G32Z-7](#) [74LVC1G86Z-7](#) [NLV74HC14ADR2G](#) [NLV74HC20ADR2G](#)
[NLVVHC1G09DFT1G](#) [NLX2G86MUTCG](#) [74LVC2G32RA3-7](#) [74LVC2G00HD4-7](#) [NL17SG02P5T5G](#) [74LVC2G86HK3-7](#)
[NLV7SZ97DFT2G](#) [NLVVHC1G14DFT2G](#) [NLX1G99DMUTWG](#) [NLVVHC1G00DFT2G](#) [NLV7SZ57DFT2G](#) [NLV74VHC04DTR2G](#)
[NLV27WZ00USG](#) [NLU1G86CMUTCG](#) [NLU1G08CMUTCG](#) [NL17SZ32P5T5G](#) [NL17SZ00P5T5G](#) [NL17SH02P5T5G](#) [74AUP2G00RA3-7](#)
[NLVVHC1GT00DFT2G](#) [NLV74HC02ADTR2G](#) [NLX1G332CMUTCG](#) [NLVHCT132ADTR2G](#) [NL17SG86P5T5G](#) [NL17SZ05P5T5G](#)
[NLV74VHC00DTR2G](#) [NLVVHC1G02DFT1G](#) [NLV74HC86ADR2G](#)