

ISSUE : Jan 11, 2018

TO ;  
\_\_\_\_\_

## S P E C I F I C A T I O N S

Product Name     Dust Sensor  
\_\_\_\_\_

Model No.     G P 2 Y 1 0 2 6 A U O F  
\_\_\_\_\_

These specifications contain 14 pages including the cover and appendix.  
This specification sheets and attached sheets shall be both side copy.  
After confirmation of the contents, please be sure to send back 1 copy of the  
Specifications with approving signature on each.  
If you have any objections, please contact us before issuing purchasing order.

Accepted by:

By : \_\_\_\_\_

Name :

Title :

Date :

By : \_\_\_\_\_

Name :

Title :

Date :

Sharp Corporation

By : 

Name : T. Ichinose,

Title : Division Manager,

Development Division. V

Semiconductor Business Unit

Electronic Components and Devices BU

Date : 

Reviewed by :

By : 

Name : A. Yamaguchi

Title : Associate Manager

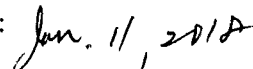
Date : 

Prepared by :

By : 

Name : M. Okami

Title : Supervisor

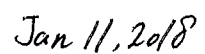
Date : 

1. These specification sheets include materials protected under copyright of Sharp Corporation ("Sharp").  
Please handle with great cares and do not reproduce or cause anyone to reproduce them without Sharp's consent.
2. When using this Sharp product, please observe the absolute maximum ratings, other conditions and instructions for use described in the specification sheets, as well as the precautions mentioned below.  
Sharp assumes no responsibility for any damages resulting from use of the product which does not comply with absolute maximum ratings, other conditions and instructions for use included in the specification sheets, and the precautions mentioned below.

(Precautions)

- (1) In making catalogue or instruction manual based on the specification sheets, please verify the validity of the catalogue or instruction manuals after assembling Sharp products in customer's products at the responsibility of customer.
- (2) This Sharp product is designed for use in the following application areas ;
  - Computers • OA equipment • Telecommunication equipment (Terminal) • Measuring equipment
  - Tooling machines • Audio visual equipment • Home appliancesIf the use of the Sharp product in the above application areas is for equipment listed in paragraphs (3) or (4), please be sure to observe the precautions given in those respective paragraphs.
- (3) Appropriate measures, such as fail-safe design and redundant design considering the safety design of the overall system and equipment, should be taken to ensure reliability and safety when Sharp product is used for equipment in responsibility of customer which demands high reliability and safety in function and precision, such as ;
  - Transportation control and safety equipment (aircraft, train, automobile etc.)
  - Traffic signals • Gas leakage sensor breakers • Rescue and security equipment
  - Other safety equipment
- (4) Sharp product is designed for consumer goods and controlled as consumer goods in production and quality.  
Please do not use this product for equipment which require extremely high reliability and safety in function and precision, such as ;
  - Space equipment • Telecommunication equipment (for trunk lines)
  - Nuclear power control equipment • Medical equipment
- (5) Please contact and consult with a Sharp sales representative if there are any question regarding interpretation of the above four paragraphs.

3. Disclaimer

The warranty period for Sharp product is one (1) year after shipment.  
During the period, if there are any products problem, Sharp will repair (if applicable), replace or refund.  
Except the above, both parties will discuss to cope with the problems.

The failed Sharp product after the above one (1) year period will be coped with by Sharp, provided that both parties shall discuss and determine on sharing responsibility based on the analysis results thereof subject to the above scope of warranty.

The warranty described herein is only for Sharp product itself which are purchased by or delivered to customer.  
Damages arising from Sharp product malfunction or failure shall be excepted.

Sharp will not be responsible for the Sharp product due to the malfunction or failures thereof which are caused by:

- (1) storage keep trouble during the inventory in the marketing channel.
- (2) intentional act, negligence or wrong/poor handling.
- (3) equipment which Sharp products are connected to or mounted in.
- (4) disassembling, reforming or changing Sharp products.
- (5) installation problem.
- (6) act of God or other disaster (natural disaster, fire, flood, etc.)
- (7) external factors (abnormal voltage, abnormal electromagnetic wave, fire, etc.)
- (8) special environment (factory, coastal areas, hot spring area, etc.)
- (9) phenomenon which cannot be foreseen based on the practical technologies at the time of shipment.
- (10) the factors not included in the product specification sheet.

4. Please contact and consult with a Sharp sales representative for any questions about Sharp product.

## 1. Application

This specification applies to the outline and characteristics of Model No. GP2Y1026AU0F (Dust sensor).

## 2. Outline

Refer to the attached drawing No. CY15345i02.

## 3. Ratings and characteristics

Refer to the attached sheet, Page 7 to 9.

## 4. Reliability

Refer to the attached sheet, Page 10.

## 5. Outgoing inspection

Refer to the attached sheet, Page 11.

## 6. Supplements

## 6-1 Dust density characteristics[Example]:

Refer to the attached sheet, Page 12.

## 6-2 This product shall not contain the following materials.

Also, the following materials shall not be used in the production process for this product.

Materials for ODS : CFCs, Halon, Carbon tetrachloride, 1.1.1-Trichloroethane (Methylchloroform)

## 6-3 Specified brominated flame retardants

Specified brominated flame retardants (PBB and PBDE) are not used in this device at all.

## 6-4 Product mass : Approx. 17g

## 6-5 Packaging specification : Refer to the attached sheet, Page 13.

## 6-6 Compliance with each regulation

## 6.6.1 The RoHS directive(2011/65/EU)

This product complies with the RoHS directive(2011/65/EU) .

Object substances: mercury, lead, cadmium, hexavalent chromium, polybrominated biphenyls (PBB) and polybrominated diphenyl ethers (PBDE)

## 6.6.2 Content of six substances specified in Management Methods for Control of Pollution Caused by Electronic Information Products Regulation (Chinese : 电子信息产品污染控制管理办法).

Marking Styles for the Names and Contents of the Hazardous Substances

Category	Hazardous Substances					
	Lead (Pb)	Mercury (Hg)	Cadmium (Cd)	Hexavalent chromium (Cr <sup>6+</sup> )	Polybrominated biphenyls (PBB)	Polybrominated diphenyl ethers (PBDE)
Dust sensor	×	○	○	○	○	○

This table is prepared in accordance with the provisions of SJ/T 11364.

○ : Indicates that said hazardous substance contained in all of the homogeneous materials for this part is below the limit requirement of GB/T 26572

× : Indicates that said hazardous substance contained in at least one of the homogeneous materials used for this part is above the limit requirement of GB/T 26572

Lead in glass of electronic components (designated by “×” in the above table) are exempt from the RoHS directive (2011/65/EC) , because there is no effective way to eliminate or substitute them by present scientific technology.

## 7. Notes

### 7-1 Connection of case and GND

Case material use conductive resin as cover case (printed model No.) and metal (test terminal side) as bottom cover. The metal case connects with GND in sensor.

### 7-2 Cleaning

Please don't do cleaning, because there is a case that this device is not satisfied with its characteristics by cleaning.

### 7-3 Dust Adhesion

There is a case that this product does not detect the dust density correctly, since the dust adhered to the inside of the dust through hole may project into the detecting space which consist of emitter and detector light axis. Please take the structure and mechanism of the equipment into consideration to avoid the influence of adhered dust. And when the dust is adhered. Please consider the maintenance such as vacuuming or blowing off the dust by air.

In addition, in case the foreign substance such as dust is attached to the optical system consist of light emitting diode, light detector, lens and so on, and the inner portion of case, there is a variation in output at no dust of this sensor. Please make allowance for the error in dust detection based on initial output at no dust of this sensor.

### 7-4 Light output

In circuit designing, make allowance for the degradation of the light emitting diode output that results from long continuous operation. (50% degradation/5years)

### 7-5 Sensitivity adjustment VR

VR for sensitivity adjustment is set up at shipping from Sharp.

Please do not touch the VR or Electro-optical characteristics specified on the specification will be invalid.

### 7-6 Resolution

Please do not disassemble the device such as removing a tapping screw and so on.

Even if the device is reassembled, it may not satisfy the specification.

### 7-7 Application to fire alarm

Please do not use this device for a fire alarm application. When using this device to application other than air purifying and equipment with air purifying function, please inform us before usage.

### 7-8 Noise influence

If the sensor is located close to noise source (ex. Electric dust collector, etc.).

The sensor output may be affected by leaded noise.

On top of that noise from power supply line also may affect the sensor output.

When designing the system, please consider the effect from noise.

### 7-9 Vibration influence

The sensor may change its output value under mechanical oscillation.

Before usage, please make sure that the device works normally in the application.

### 7-10 Incident light influence

There is a case that the sensor output may be affected when outer-light comes through dust through hole on printed side.

In order to avoid any influence from outer-light, please locate the printed side of the sensor facing to inside of the application.

**7-11 Dewing**

When inside of the sensor is moisturized, this product does not keep its proper function.  
Please design the application so that moisturization of the sensor does not happen.

**7-12 NC pin handling**

Without connecting about a NC terminal for a sensor, please use as an OPEN terminal.

2. Outline

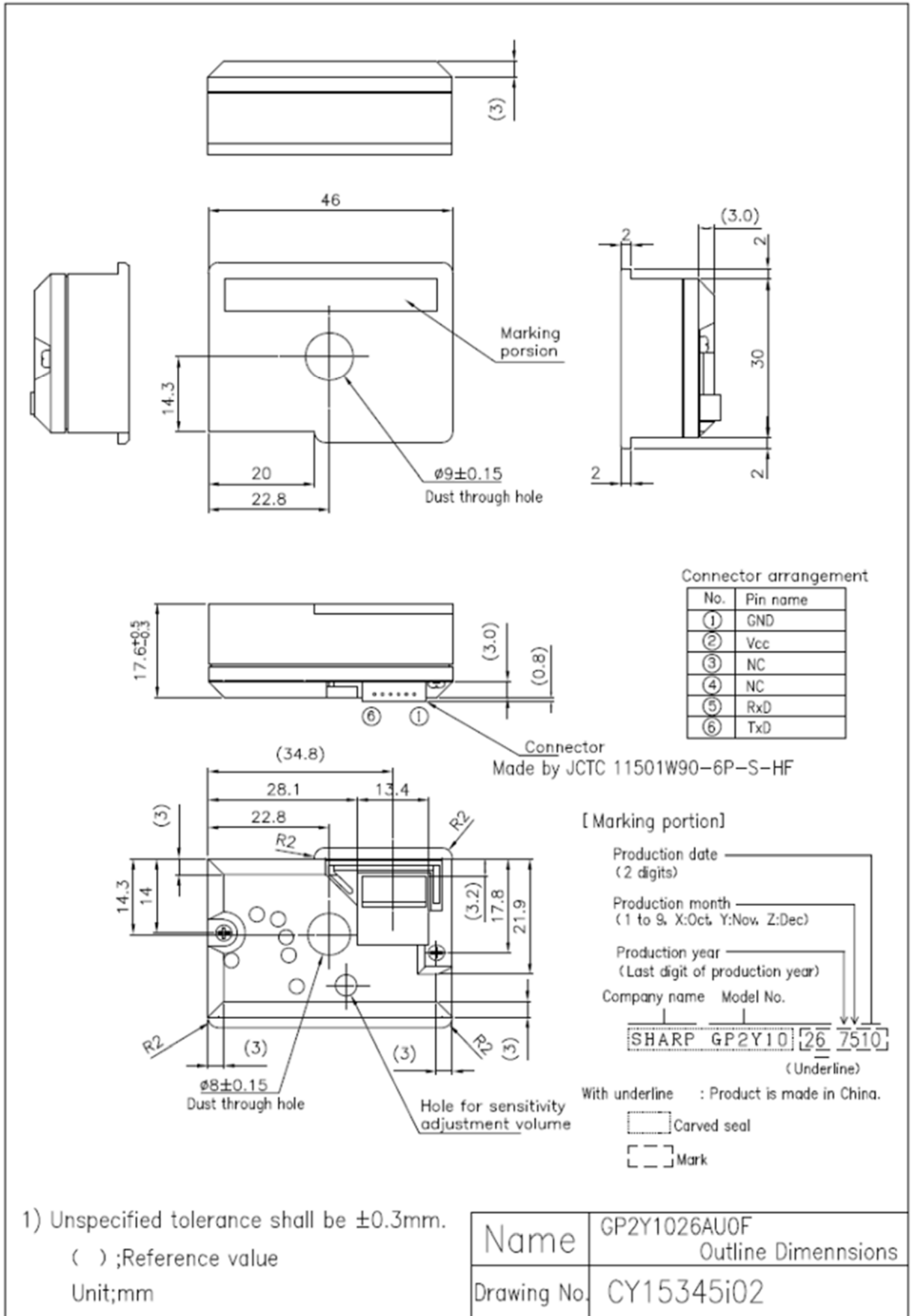

## 3. Ratings and characteristics

## 3-1 Constitution diagram

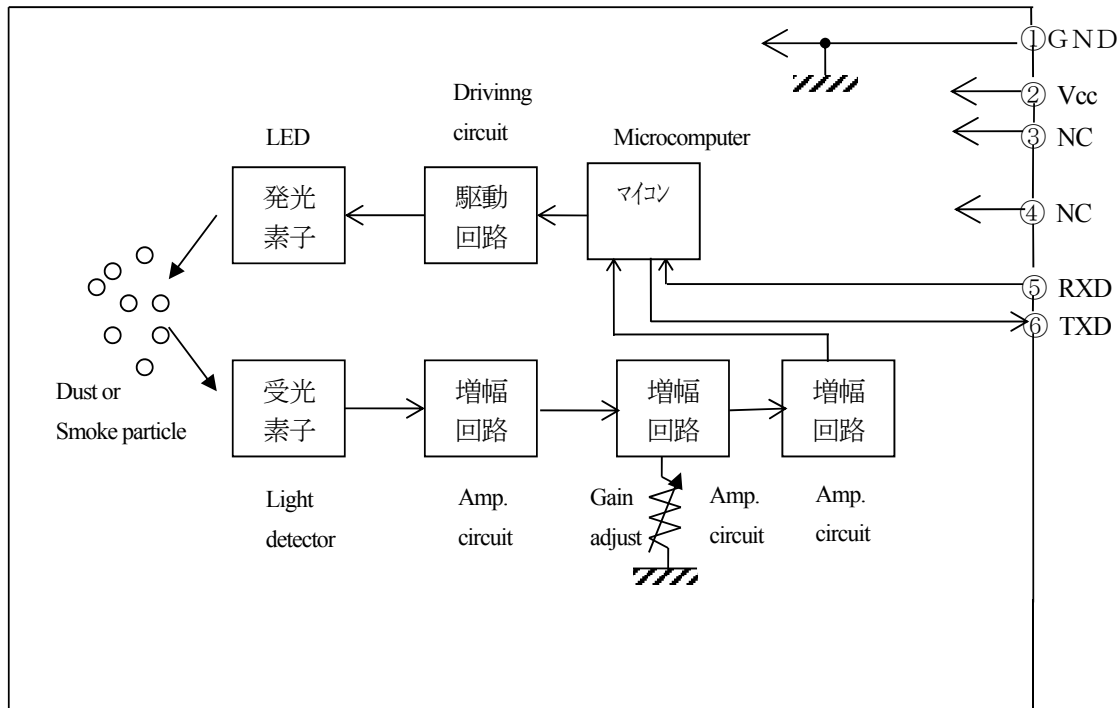

## 3-2 Absolute maximum ratings

(Ta=25°C)

Parameter	Symbol	Rating	Unit	Remark
Supply voltage	Vcc	-0.3 to +6	V	—
Input terminal voltage	V <sub>RXD</sub>	-0.3 to Vcc	V	—
Operating temperature	Topr	-10 to +65	°C	—
Storage temperature	Tstg	-20 to +80	°C	—

## 3-3 Operating Supply Voltage

Symbol	Rating	Unit	Remark
Vcc	5±0.2	V	—

## 3-4 Electro-optical Characteristics

(Ta=25°C, Vcc=5V)

Parameter	Symbol	Conditions	Min.	Typ.	Max.	Unit
Sensitivity	K	(*1)(*2)	0.29	0.35	0.41	V / (0.1mg/m <sup>3</sup> )
Sensitivity Output at no dust	$\Delta V_o$	(*1)(*2)	0	-	-	V
Output terminal voltage	Txdh	Output voltage at High-level (Ioh=1.5mA)	4.35	—	—	V
	Txdl	Output voltage at Low-level (Ioh=1.5mA)	—	—	0.8	V
Average supply current	I <sub>CC</sub>	Vcc=5V	-	15	20	mA

(\*1) Dust density shall be measured the density of MEVIUS (made by Japan Tobacco Inc.) by using a digital dust indicator P-5L2 (made by SIBATA SCIENTIFIC TECHNOLOGY LTD.).

Sensitivity : K shall be specified about output change when dust density is changed 0.1mg/m<sup>3</sup>

(\*2) Connection circuit example.

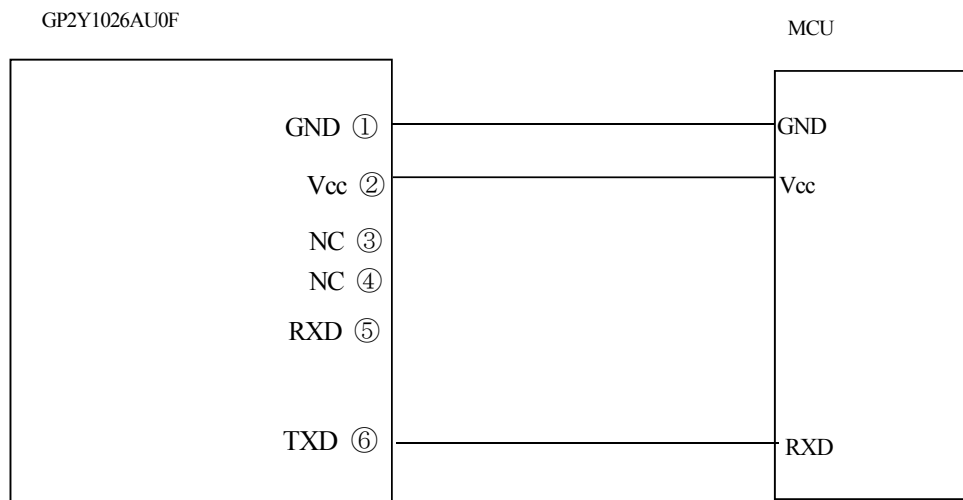

\*) Without connecting about a RXD terminal for a sensor, please use as an OPEN terminal.



## 3-4 The detail of Serial output

- 1) Transmission rate: 2400 bit/s
- 2) 1 byte transmits every 10ms (The 7 bytes output in total) (Checksum=Vout (H)+ Vout (L)+Vref (H)+ Vref(L));
- 3) Data transmission format:

Start	Vout (H)	Vout (L)	Vref (H)	Vref (L)	Checksum	End
0xaa	Ex: 0x01	Ex: 0x3a	Ex: 0x00	Ex: 0x7a	Ex: 0xb5	0xff

- 4) Data handling:

Calculating formula of output voltage Vout :  $Vout = (Vout (H) * 256 + Vout (L)) / 1024 * 5$

Ex: Vout (H)=0x01, Decimal number 1;

Vout (L)=0x3a, Decimal number 58;

$Vout = (1 * 256 + 58) / 1024 * 5 = 1.533V$ ; (Vout is data update every approximately one second)

## 4. Reliability

The reliability of products shall be satisfied with items listed below.

Confidence level : 90%

LTPD : 20 or 30

No.	Test Items	Test Conditions	Failure Judgment Criteria	Samples (n) Defective(C)
	Temperature cycling		$I_{cc} > U \times 1.2$  U : Upper specification limit L : Lower specification limit	n=11, c=0
2	High temp. and high humidity storage	+60°C, 90%RH, 500h	<The appearance> Appearance defect that affect the electrical optical characteristic.	n=11, c=0
3	High temp. and high humidity operation	+60°C, 90%RH, V <sub>cc</sub> =5V, 500h		n=11, c=0
4	High temp. storage	+80°C, 500h		n=11, c=0
5	High temp. operation	65°C, V <sub>cc</sub> =5V, 500h		n=11, c=0
6	Low temp. storage	-20°C, 500h		n=11, c=0
7	Low temp. operation	-10°C, V <sub>cc</sub> =5V, 500h		n=11, c=0
8	Mechanical shock	1000m/s <sup>2</sup> , 6.0ms 3times/±X, ±Y, ±Z direction		n=8, c=0
9	Variable frequency Vibration	5 to 55 to 5Hz/1min. overall amplitude : 1.5mm 2h/X, Y, Z direction		n=8, c=0

\*1 Test conditions are according to 3-4 Electro-optical characteristics.

\*2 After test, measurement shall be done after leaving under the normal temperature and the normal humidity for 2h. And there should be no dew.

\*3 These test results are sampling examples from a specific lot for reference purpose only, and do not constitute any warranty or assurance in connection with the products.

## 5. Outgoing inspection

## (1) Inspection lot

Inspection shall be carried out per each delivery lot.

## (2) Inspection method

A single sampling plan, normal inspection level II based on ISO 2859 shall be adopted.

Defect	Inspection item	AQL (%)
Major defect	Electro-optical characteristics defect (In para. 3-4)	0.4
Minor defect	Defect on appearance and dimension ※ Split, chip, scratch, stain	1.0

※ Split, chip, scratch, stain

One which affects the characteristics of para. 3-4 shall be defect.

※ Rust shall not be defect.

## 6-1 Dust density characteristics[Example]

Test conditions are according to 3-4 Electro-optical characteristics.

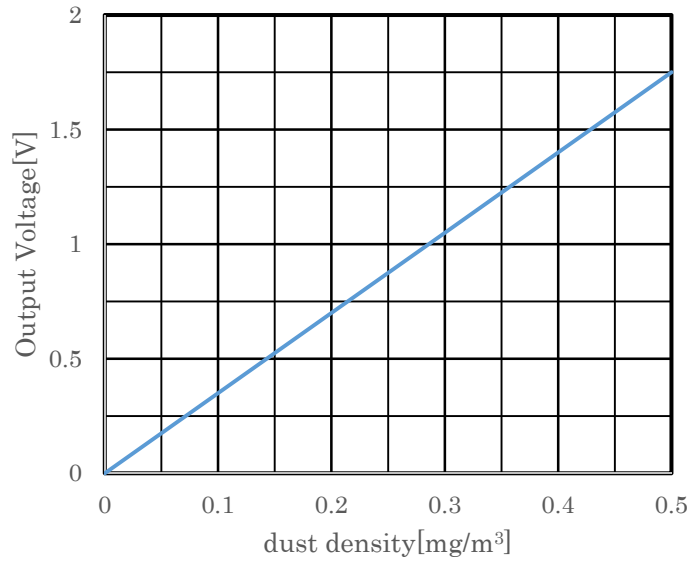

6-5 Packaging specification

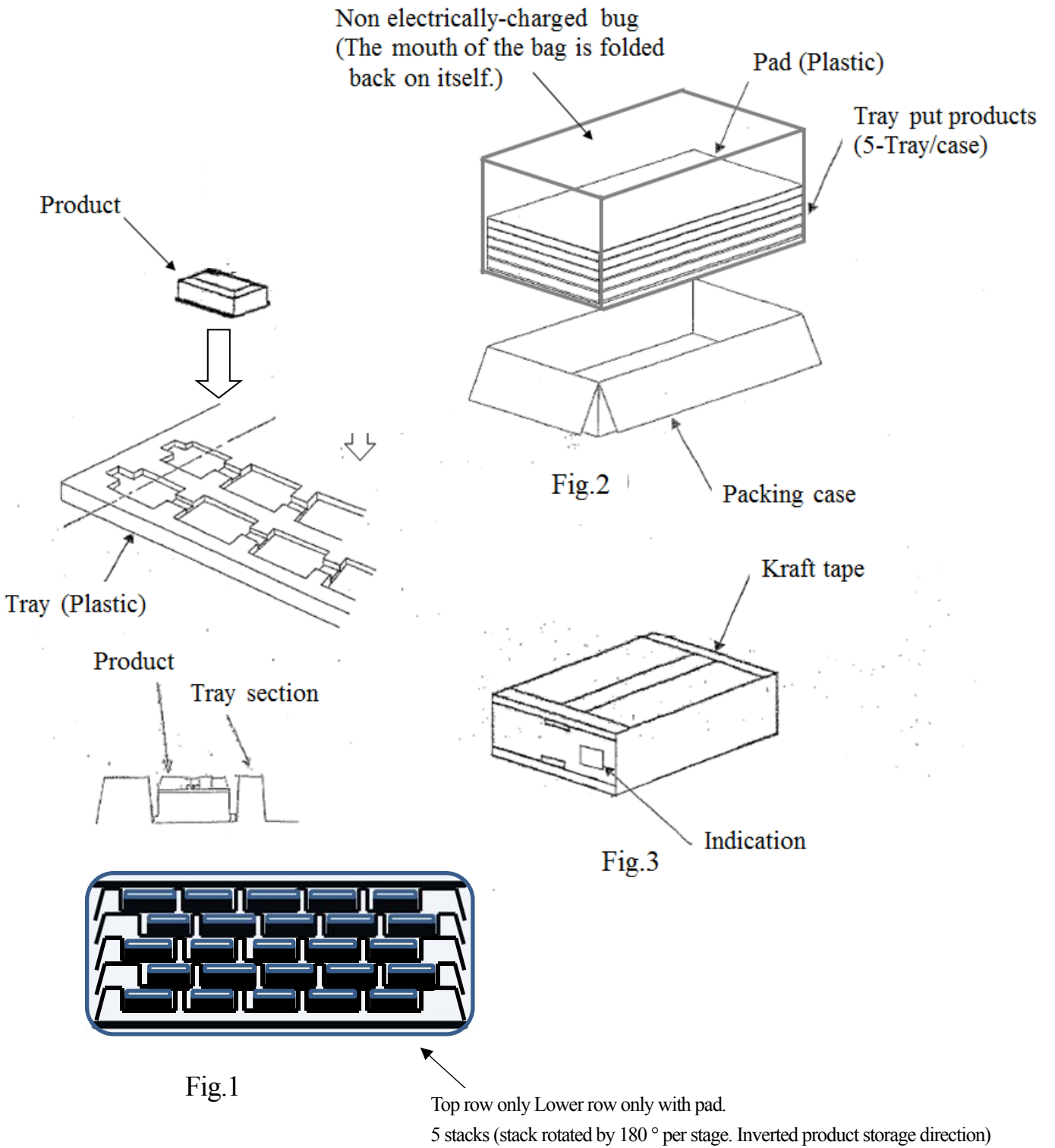

<h2>Packaging method</h2>
---------------------------

1. Store 50 products in tray. (The storage method is shown in the figure.)  
While stacking the product, turn the tray 180 degrees and stack it in 5 rows.  
Pads are put only on the top and bottom. (Fig.1)
2. Store trays containing products that are stacked in five layers in a non electrically-charged bag. (Fig.2)
3. Put them (5 trays) in the packing box.  
The mouth of the bag shall be put one on top of another.
4. Seal the packing box with kraft tape.  
Put a label with Model No., Quantity, Lot No. on it. (Fig.3)
5. Indication items  
The contents of the carton indication conforms to EIAJ C-3 and the following items are indicated.  
Model No., Internal production control name, Quantity, Packing date,  
Corporate name, Country of origin  
(250pcs/a packing box)  
(Formal packed mass : Approximately 5.6kg)

## X-ON Electronics

Largest Supplier of Electrical and Electronic Components

*Click to view similar products for [Air Quality Sensors](#) category:*

*Click to view products by [Sharp](#) manufacturer:*

Other Similar products are found below :

[GMS-MSTH2.S.V.3](#) [MO86571](#) [MO86561](#) [076074 01](#) [DE800.A.1](#) [MF010-2-LC1](#) [MF020-2-LC3](#) [KGZ10-5PIN](#) [GMS10SENSORS](#) [IR25TT](#)  
[208280-0001](#) [IR11BD](#) [IR11GM](#) [IR12GM](#) [IR21BD](#) [GMS10-18C](#) [KGZ12](#) [S-300L-3V-5000-SLEEP-UART](#) [MP7227-TC](#) [OXY-LC-A25-455](#)  
[SGPC3-TR-2.5KS](#) [T6713-6H](#) [POLOLU-1482](#) [3.000.475](#) [3.000.496](#) [HPMA115S0-XXX](#) [SGPC3-2.5k](#) [T3032-2-10K-24-P](#) [VQ6MB](#) [INIR-CD-](#)  
[5%](#) [VQ23TB](#) [IR11GJ](#) [VQ31MB](#) [IR11BR](#) [GP2Y1026AU0F](#) [VQ549ZD](#) [MHM501-00](#) [MHM500-00A](#) [MHM305-01](#) [MICS-4514](#) [VQ548ZD-](#)  
[S](#) [SEN-09403](#) [IR15TT](#) [MICS-5524](#) [MICS-5914](#) [MICS-2714](#) [INIR-ME-100%](#) [T8100-D](#) [VQ21TB](#) [IR21EJ](#)