

ISSUE: May 20, 2020

TO ;

S P E C I F I C A T I O N S

Product Name PHOTOCOUPLER

Model No. PC923L

【Business dealing name : PC923LR*SZ0F】
(CHINA products)

These specifications contain 18 pages including the cover and appendix.
This specification sheets and attached sheets shall be both side copy.
After confirmation of the contents, please be sure to send back copy of the
Specifications with approving signature on each.
If you have any objections, please contact us before issuing purchasing order.

Accepted by:

Sharp Corporation

By: _____

By: JK

Name:

Name: T. Kamiyoshi

Title:

Title: Senior Manager

Date:

Electronic Components and Devices Account Div.

Date: May, 22, 2020

By: _____

Sharp Fukuyama Semiconductor Co., Ltd.

Name:

By: T.H.

Title:

Name: T. Hiramatsu

Date:

Title: Division Manager

Sensor Development Div. II

Semiconductor Business Unit

Date: May 22, 2020

Reviewed by:

Prepared by:

By: K.I.By: H.S.

Name: K. Iwamoto

Name: H. Shoji

Title: Senior Manager

Title: Supervisor

Date: May, 22, 2020Date: May 22, 2020



1. These specification sheets include materials protected under copyright of Sharp Corporation ("Sharp").
Please handle with great cares and do not reproduce or cause anyone to reproduce them without Sharp's consent.
2. When using this Sharp product, please observe the absolute maximum ratings, other conditions and instructions for use described in the specification sheets, as well as the precautions mentioned below.
Sharp assumes no responsibility for any damages resulting from use of the product which does not comply with absolute maximum ratings, other conditions and instructions for use included in the specification sheets, and the precautions mentioned below.

(Precautions)

- (1) In making catalogue or instruction manual based on the specification sheets, please verify the validity of the catalogue or instruction manuals after assembling Sharp products in customer's products at the responsibility of customer.
- (2) This Sharp product is designed for use in the following application areas ;
 - Computers • OA equipment • Telecommunication equipment (Terminal) • Measuring equipment
 - Tooling machines • Audio visual equipment • Home appliances
 If the use of the Sharp product in the above application areas is for equipment listed in paragraphs (3) or (4), please be sure to observe the precautions given in those respective paragraphs.
- (3) Appropriate measures, such as fail-safe design and redundant design considering the safety design of the overall system and equipment, should be taken to ensure reliability and safety when Sharp product is used for equipment in responsibility of customer which demands high reliability and safety in function and precision, such as ;
 - Transportation control and safety equipment (aircraft, train, automobile etc.)
 - Traffic signals • Gas leakage sensor breakers • Rescue and security equipment
 - Other safety equipment
- (4) Sharp product is designed for consumer goods and controlled as consumer goods in production and quality.
Please do not use this product for equipment which require extremely high reliability and safety in function and precision, such as ;
 - Space equipment • Telecommunication equipment (for trunk lines)
 - Nuclear power control equipment • Medical equipment
- (5) Please contact and consult with a Sharp sales representative if there are any question regarding interpretation of the above four paragraphs.

3. Disclaimer

The warranty period for Sharp product is one (1) year after shipment.
During the period, if there are any products problem, Sharp will repair (if applicable), replace or refund.
Except the above, both parties will discuss to cope with the problems.

The failed Sharp product after the above one (1) year period will be coped with by Sharp, provided that both parties shall discuss and determine on sharing responsibility based on the analysis results thereof subject to the above scope of warranty.

The warranty described herein is only for Sharp product itself which are purchased by or delivered to customer.
Damages arising from Sharp product malfunction or failure shall be excepted.

Sharp will not be responsible for the Sharp product due to the malfunction or failures thereof which are caused by:

- (1) storage keep trouble during the inventory in the marketing channel.
- (2) intentional act, negligence or wrong/poor handling.
- (3) equipment which Sharp products are connected to or mounted in.
- (4) disassembling, reforming or changing Sharp products.
- (5) installation problem.
- (6) act of God or other disaster (natural disaster, fire, flood, etc.)
- (7) external factors (abnormal voltage, abnormal electromagnetic wave, fire, etc.)
- (8) special environment (factory, coastal areas, hot spring area, etc.)
- (9) phenomenon which cannot be foreseen based on the practical technologies at the time of shipment.
- (10) the factors not included in the product specification sheet.

4. Please contact and consult with a Sharp sales representative for any questions about Sharp product.

1. Application

This specification applies to the outline and characteristics for OPIC type photocoupler PC923L for IGBT or MOS-FET Gate Drive.

2. Outline Refer to page 4.

3. Ratings and characteristics Refer to page 5 to 8.

4. Reliability Refer to page 9.

5. Outgoing inspection Refer to page 10.

6. Supplement

6.1 Isolation voltage shall be measured in the following method.

- (1) Short between pins 1 and 4 on the primary side and between pins 5 and 8 on the secondary side.
- (2) The dielectric withstanding tester with zero-cross circuit shall be used.
- (3) The wave form of applied voltage shall be a sine wave.

6.2 Business dealing name ("O" mark indicates business dealing name of ordered product)

Orderd product	Business dealing name	Remark
	PC923LRNSZ0F	
	PC923LRYSZ0F	Applied to product as an option (Attachment-2-1 to 2-3.)

6.3 The block diagram, Truth table

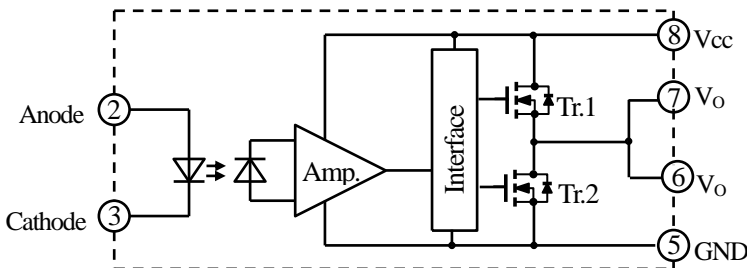

Input	V _O Output	Tr.1	Tr.2
ON	High level	ON	OFF
OFF	Low level	OFF	ON

6.4 Package specification Refer to the attached sheet, page 11 and 12.

6.5 This Model is approved by UL. (Under preparation)

Approved Model No. : PC923L
 UL file No. : E64380

6.6 About radiation resistant design

- (1) This product is not designed against irradiation.
- (2) This product is assembled with electrical input and output.
- (3) This product incorporates non-coherent light emitting diode.

6.7 ODS materials

- (1) This product shall not contain the following materials.
- (2) Also, the following materials shall not be used in the production process for this product.
 Materials for ODS : CFCs, Halon, Carbon tetrachloride, 1.1.1-Trichloroethane (Methyl chloroform)

6.8 Specified brominated flame retardants

Specified brominated flame retardants (PBB and PBDE) are not used in this device at all.

6.9 Compliance with each regulation

- (1) This product complies with EU RoHS Directive (2011/65/EU) and Commission Delegated Directive (EU)2015/863
- (2) Content of six substances specified in Management Methods for Control of Pollution Caused by Electronic Information Products Regulation (Chinese : 电子信息产品污染控制管理办法).

Marking Styles for the Names and Contents of the Hazardous Substances

Category	Hazardous Substances					
	Lead (Pb)	Mercury (Hg)	Cadmium (Cd)	Hexavalent chromium (Cr ⁶⁺)	Polybrominated biphenyls (PBB)	Polybrominated diphenyl ethers (PBDE)
Photocoupler	○	○	○	○	○	○

This table is prepared in accordance with the provisions of SJ/T 11364.

○ : Indicates that said hazardous substance contained in all of the homogeneous materials for this part is below the limit requirement of GB/T 26572.

7. Notes

Precautions for photocouplers : Attachment-1.

(Notice)

The contents described herein are subject to change without notice for improvement since this product is under development.

2. Outline

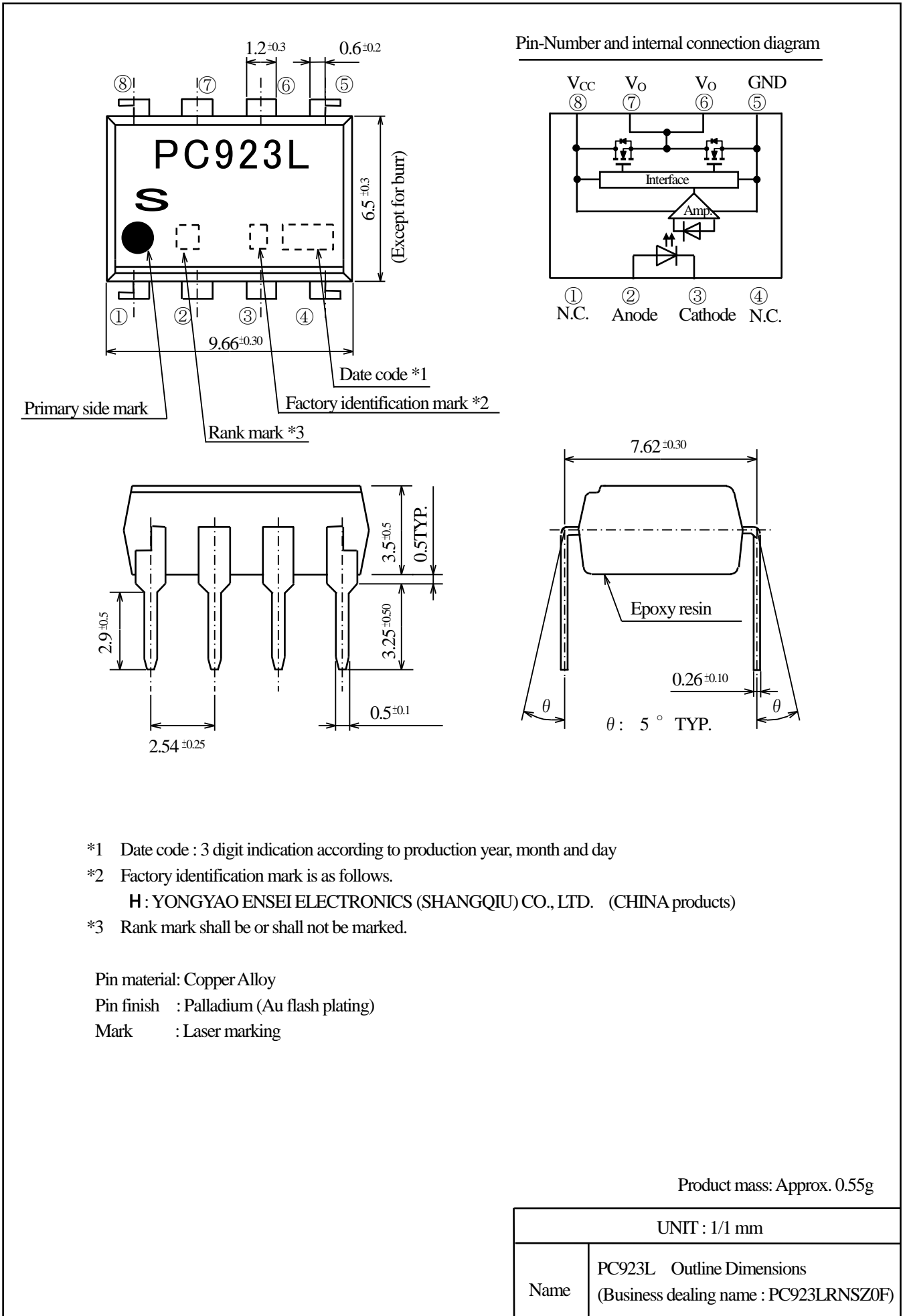

*1 Date code : 3 digit indication according to production year, month and day

*2 Factory identification mark is as follows.

H: YONGYAO ENSEI ELECTRONICS (SHANGQIU) CO., LTD. (CHINA products)

*3 Rank mark shall be or shall not be marked.

Pin material: Copper Alloy

Pin finish : Palladium (Au flash plating)

Mark : Laser marking

Product mass: Approx. 0.55g

UNIT : 1/1 mm

Name	PC923L Outline Dimensions (Business dealing name : PC923LRNSZ0F)
------	---

3. Ratings and characteristics

3.1 Absolute maximum ratings

Ta=25°C

Parameter		Symbol	Rating	Unit
Input	*1 Forward current	I_F	25	mA
	Reverse voltage	V_R	5	V
	*4 Peak forward current	I_{FM}	1	A
Output	Supply voltage	V_{CC}	35	V
	*5 Peak output current	$I_{O(PEAK)}$	1.5	A
	Output voltage	V_O	V_{CC}	V
	*2 Power dissipation	P_O	250	mW
*3 Total power dissipation	P_{tot}	295	mW	
*6 Isolation voltage	$V_{iso(ms)}$	5.0	kV	
Operating temperature		T_{opr}	-40 to +100	°C
Storage temperature		T_{stg}	-55 to +125	°C
Soldering temperature		T_{sol}	270 (For 10s)	°C

*1 When ambient temperature goes above 70°C, the power dissipation goes down at the rate of 0.3mA/°C. (Fig. 10)

*2 When ambient temperature goes above 70°C, the power dissipation goes down at the rate of 4.6mW/°C. (Fig. 11)

*3 When ambient temperature goes above 70°C, the power dissipation goes down at the rate of 5.4mW/°C. (Fig. 12)

The maximum LED junction temperature should not exceed 125°C

*4 Pulse width $\leq 1 \mu s$, 300pps

*5 Pulse width $\leq 10 \mu s$, Duty ratio : 0.002

*6 AC for 1 min, 40 to 60%RH, Ta=25°C

3.2 Electro-optical characteristics *7 *13

(Unspecified : Ta= -40 to +100°C, I_{F(ON)}=7 to 16mA, V_{CC}=15 to 30V, V_{F(OFF)}= -3 to 0.8V)

Parameter		Symbol	MIN.	TYP.	MAX.	Unit	Test circuit	Conditions	
Input	Forward voltage	V _F	1.2	-	1.8	V	-	Ta=25°C, I _F =10mA	
	Reverse current	I _R	-	-	10	μA	-	V _R =5V	
	Terminal capacitance	C _t	-	60	150	pF	-	Ta=25°C, V=0, f=1MHz	
Output	High level output current	I _{OH}	0.3	1.0	-	A	(1)	V _O =(V _{CC} -4V), I _{F(ON)} *8	
			1.0	-	-	A		V _O =(V _{CC} -15V), I _{F(ON)} *9	
	Low level output current	I _{OL}	0.3	1.0	-	A	(2)	V _O =2.5V, V _{F(OFF)} *8	
			1.0	-	-	A		V _O =15V, V _{F(OFF)} *9	
	High level output voltage	V _{OH}	V _{CC} -0.6	V _{CC} -0.4	-	V	(3)	I _O = -0.1A, I _{F(ON)}	
	Low level output voltage	V _{OL}	-	0.1	0.5	V	(4)	I _O =0.1A, V _{F(OFF)}	
	High level supply current *10	I _{CCH}	-	-	3.0	mA	(5)	I _{F(ON)}	
	Low level supply current *10	I _{CCL}	-	-	3.0	mA		V _{F(OFF)}	
	UVLO Threshold	V _{UVLO+}	6.9	7.8	8.7	V	(6)	V _O >5V, I _F =10mA	
			V _{UVLO-}	5.9	6.7	7.5			V
UVLO Hysteresis	UVLO _{HYS}	-	1.1	-	V				
Transfer characteristics	"L→H" threshold input current *11	I _{FLH}	-	-	5.0	mA	(7)	V _O >5V, I _O =0	
	Isolation resistance	R _{ISO}	5×10 ¹⁰	10 ¹¹	-	Ω	-	Ta=25°C, DC=500V, 40 to 60%RH	
	Response time	"L→H" propagation delay time	t _{PLH}	-	0.2	0.5	μs	(8)	R _G =47Ω, C _G =3nF f=10kHz, Duty ratio 50%
		"H→L" propagation delay time	t _{PHL}	-	0.2	0.5			
		Distortion of pulse width *12	Δt _w	-	0.02	-			
		Propagation delay skew	t _{PSK}	-0.35	-	0.35			
		Rise time	t _r	-	0.05	-			
		Fall time	t _f	-	0.05	-			
	Instantaneous common mode rejection voltage (High level output)	CM _H	15	-	-	kV/μs	(9)	Ta=25°C, V _{CM} =1.5kV(p-p) I _F =10 to 16mA, V _{CC} =30V V _{OH} >15V	
	Instantaneous common mode rejection voltage (Low level output)	CM _L	15	-	-			Ta=25°C, V _{CM} =1.5kV(p-p) V _F =0, V _{CC} =30V V _{OL} <1.0V	

*7 It is necessary connecting a by-pass capacitor of 0.1 μF or more between Vcc (Pin No. 8) and GND (Pin No. 5) near the device, when measuring the transfer characteristics and the output side characteristics.

*8 Pulse width ≤ 50 μs, Duty ratio : 0.005

*9 Pulse width ≤ 10 μs, Duty ratio : 0.002

*10 Output pin is open.

*11 I_{FLH} is the value of forward current when output changes from "L" to "H".

*12 Pulse width Δt_w = | t_{PHL} - t_{PLH} |

*13 All typical values are at Ta=25°C, V_{CC}=30V.

Test circuit

(Fig.1)

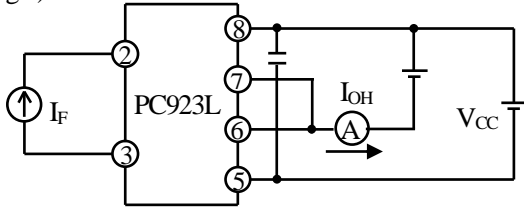

(Fig.2)

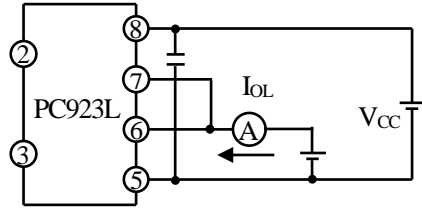

(Fig.3)

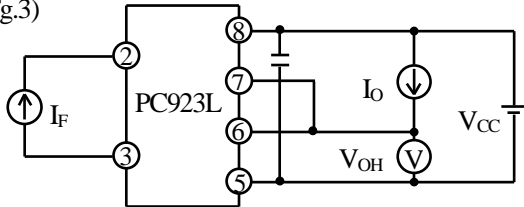

(Fig.4)

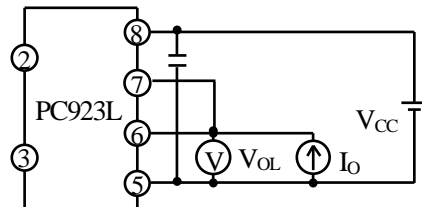

(Fig.5)

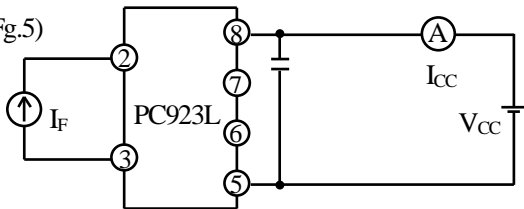

(Fig.6)

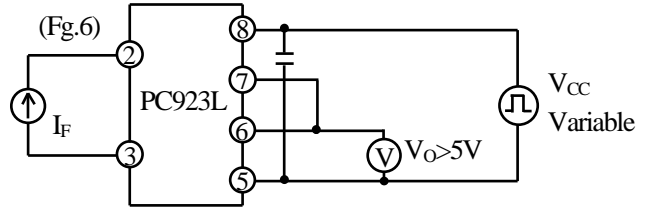

(Fig.7)

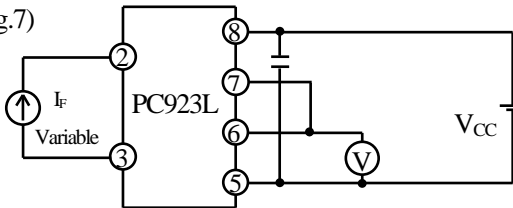

(Fig.8)

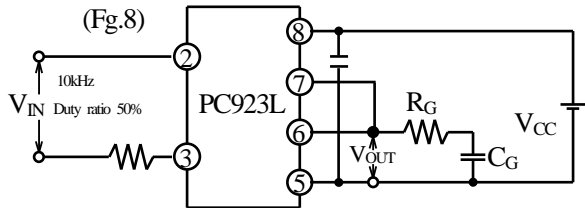

(Fig.9)

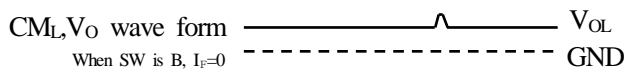
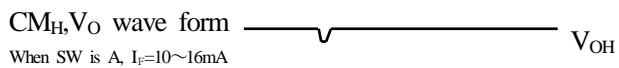
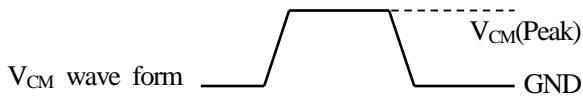
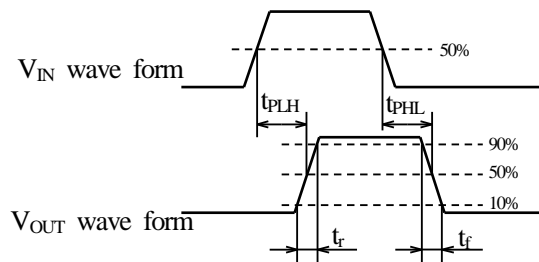
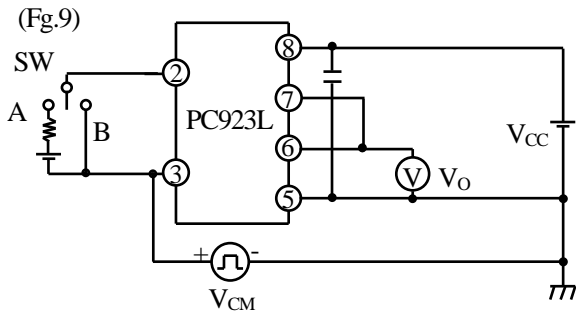

(Fig.10) Forward current vs. ambient temperature

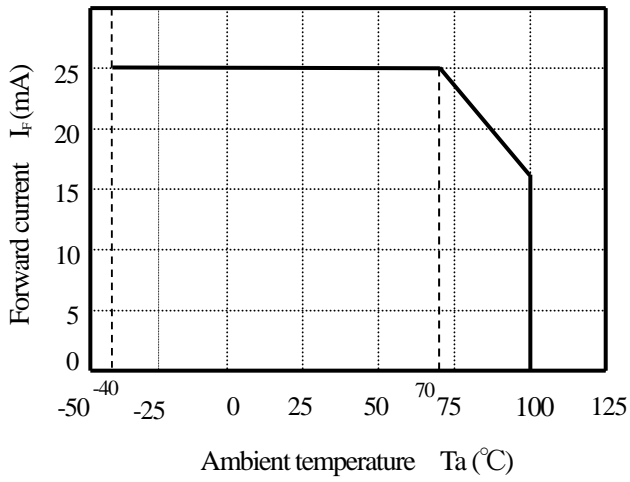

(Fig.11) Output power dissipation vs. ambient temperature

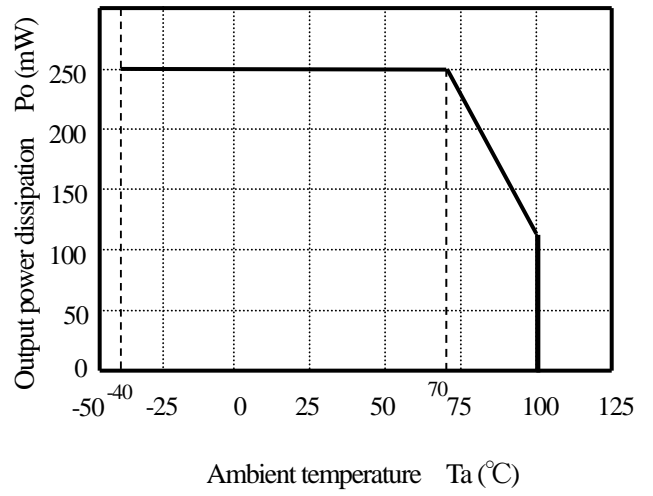

(Fig. 12) Total power dissipation vs. ambient temperature

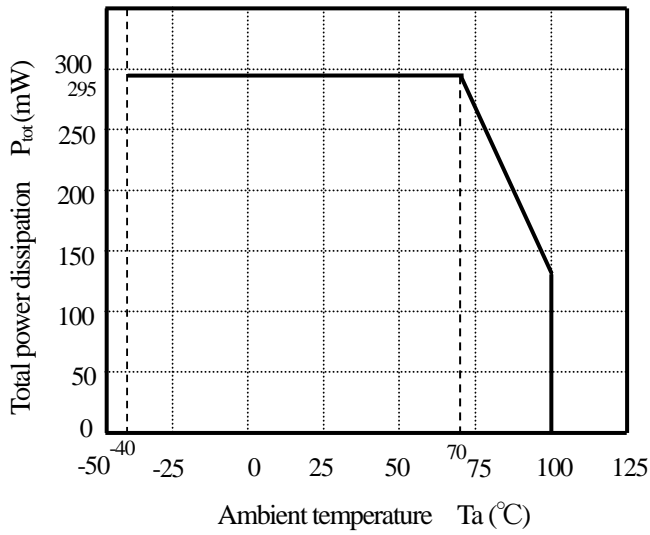

4. Reliability

The reliability of products shall satisfy items listed below.

Confidence level : 90%

LTPD : 10 or 20

Test Items	Test Conditions *1	Failure Judgment Criteria	Samples (n)
			Defective (C)
Solderability	245±3°C, 5 s	*2	n=11, C=0
Soldering heat	(Flow soldering) 270°C, 10 s	$V_F > U \times 1.2$ $I_R > U \times 2$ $V_{OL} > U \times 1.2$ $V_{OH} < L \times 0.8$ $I_{CCH} > U \times 1.2$ $I_{CCL} > U \times 1.2$ $I_{FLH} > U \times 1.3$ U: Upper specification limit L: Lower specification limit	n=11, C=0
	(Soldering by hand) 400°C, 3 s		n=11, C=0
Terminal strength (Tension)	Weight: 5N, 5 s/each terminal		n=11, C=0
Terminal strength (Bending) *3	Weight: 2.5N, 2 times/each terminal		n=11, C=0
Mechanical shock	15km/s ² , 0.5ms 3 times/±X, ±Y, ±Z direction		n=11, C=0
Variable frequency vibration	100 to 2000 to 100Hz/4 min 200m/s ² 4 times/X, Y, Z direction		n=11, C=0
Temperature cycling	1 cycle -55°C to +125°C (30 min) (30 min) 20 cycles test		n=22, C=0
High temp. and high humidity storage	+85°C, 85%RH, 1000h		n=22, C=0
High temp. storage	+125°C, 1000h		n=22, C=0
Low temp. storage	-55°C, 1000h		n=22, C=0
Operation life	I _F =25mA, V _{CC} =30V T _a =25°C, 1000h	n=22, C=0	

*1 Test method, conforms to EIAJ ED 4701.

*2 The product whose not-soldered area is more than 5% for all of the dipped area and/or whose pinholes or voids are concentrated on one place shall be judged defect.

*3 Terminal bending direction is shown below.

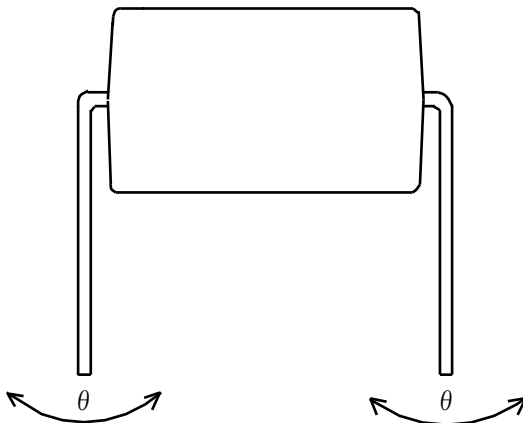

※ These test results are sampling examples from a specific lot for reference purpose only, and do not constitute any warranty or assurance in connection with the products.

5. Outgoing inspection

5.1 Inspection items

(1) Electrical characteristics

V_F , I_R , V_{OH} , V_{OL} , I_{CCH} , I_{CCL} , I_{FLH} , R_{ISO} , V_{iso}

(2) Appearance

5.2 Sampling method and Inspection level

A single sampling plan, normal inspection level II based on ISO 2859 is applied.

The AQL according to the inspection items are shown below.

Defect	Inspection item	AQL (%)
Major defect	Electrical characteristics Unreadable marking	0.065
Minor defect	Appearance defect except the above mentioned.	0.25

6.4 Package specification

6.4.1 Package materials

No.	Name	Materials	Purposes
①	Sleeve	HIPS or ABS with preventing static electricity	Products packaged
②	Stopper	Styrene-Erastomer	Products fixed
③	Packing case	Corrugated cardboard	Sleeve packaged
④	Kraft tape	Paper	Lid of packing case fixed
⑤	Label	Paper	Model No., (Business dealing name), Lot No., Quantity, Country of origin , Company name and Inspection date specified

6.4.2 Package method

- (1) MAX. 50 pcs. of products shall be packaged in a sleeve and both of sleeve ① edges shall be fixed by stoppers ②.
- (2) MAX. 20 sleeves (product ; 1,000pcs.) above shall be packaged in a packing case ③.
- (3) The label ⑤ shall be put on the side of the packing case.
- (4) Outer case shall be closed with the lid and enclosed with kraft tape ④.

6.4.3 Sleeve package outline dimensions

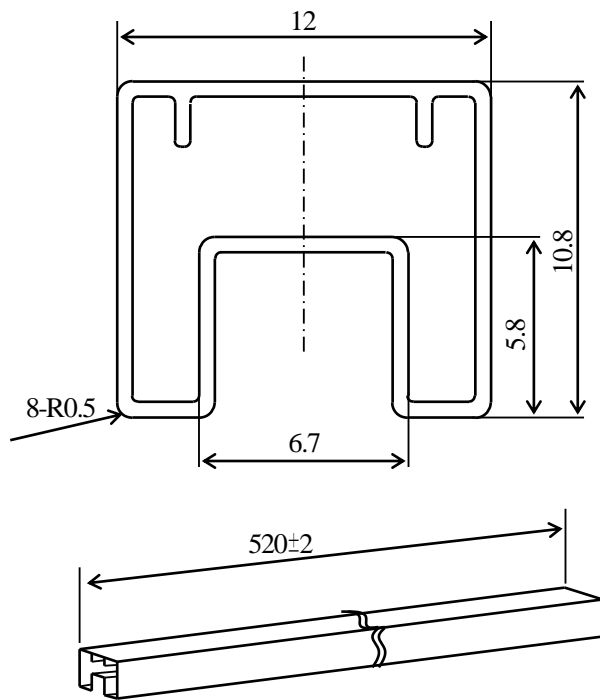

(Unit :mm)

- Note 1) Thickness : 0.5±0.2mm
 2) Process with applying antistatic treatment.
 3) Unless otherwise specified tolerances shall be ±0.5mm.
 (However except for deformation due to the rubber stopper in sleeve.)

6.4.4 Packaging outer case outline dimensions

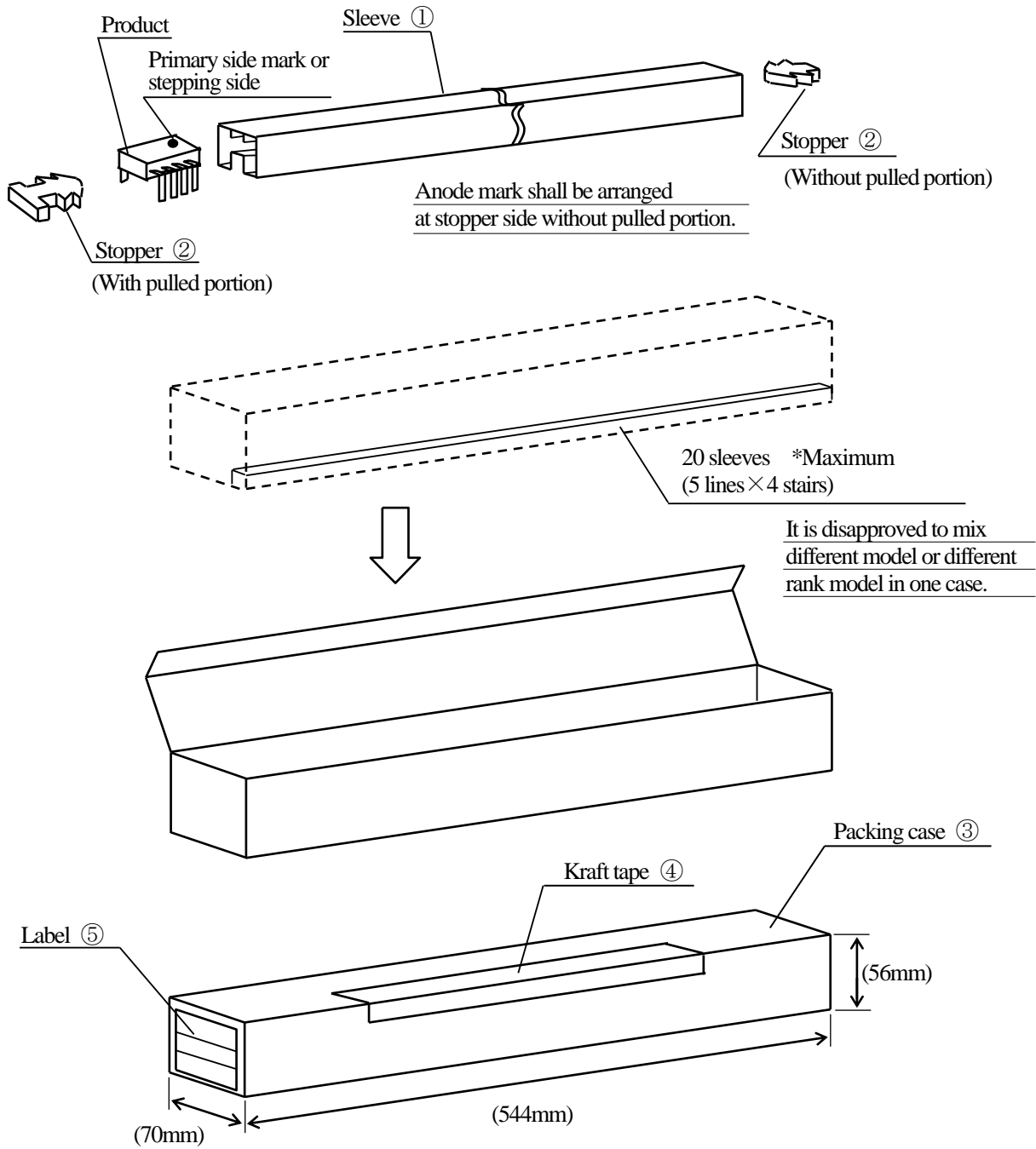

Regular packing mass : Approx. 900g

() : Reference dimensions

Precautions for Photocouplers

1. Recommended operating conditions

Parameter	Symbol	MIN.	TYP.	MAX.	Unit
Forward current (ON)	$I_{F(ON)}$	7	-	16	mA
Forward voltage (OFF)	$V_{F(OFF)}$	-3.0	-	0.8	V
Supply voltage	V_{CC}	15	-	30	V
Operating temperature	T_{opr}	-40	-	100	°C

To ensure the reliability sufficiently, please design the circuit with considering the decreases of the light emission power of the LED.

2. Cleaning

- (1) Solvent cleaning : Solvent temperature 45°C or less,
Immersion for 3 min or less
- (2) Ultrasonic cleaning : The effect to device by ultrasonic cleaning differs by cleaning bath size, ultrasonic power output, cleaning time, PCB size or device mounting condition etc.
Please test it in actual using condition and confirm that any defect doesn't occur before starting the ultrasonic cleaning.
- (3) Applicable solvent : Ethyl alcohol, Methyl alcohol, Isopropyl alcohol
When the other solvent is used, there are cases that the packaging resin is eroded.
Please use the other solvent after thorough confirmation is performed in actual using condition.

3. Static electricity

This product consist of bipolar and CMOS type device in output side and is susceptible to static electricity due to its minute design. When handling them, general countermeasure against static electricity should be taken to avoid breakdown of devices or degradation of characteristics.

4. Circuit design

- 4.1 In order to stabilize power supply line, please certainly connect a by-pass capacitor of 0.1 μ F or more between Vcc and GND near the device.
- 4.2 When steep voltage noise is applied between the primary side and the secondary side of the photocoupler, current flows or changes in the light emitting diode through a parasitic capacitance between the primary side and the secondary side of the photocoupler, then there is a case that miss operation occurs depending upon the applied noise level. We should certainly recommend to use a by-pass capacitor between both terminals of the light emitting diode when used in noisy environment.
- 4.3 The detector which is used in this device has parasitic diode between each pins and GND.
There are cases that miss operation or destruction may be occurred if electric potential of any pin fall below GND level in an instant.
Therefore it is recommended to design the circuit that electric potential of any pin does not become below GND level.
- 4.4 The LED used in the Photocoupler generally decreases the light emission power by operation.
In case of long operation time, please design I_F value so that I_F is twice or more of the Maximum value of the "H→L" threshold input current at circuit design with considering the decreases of the light emission power of the LED. (50%/5years)

5. Precautions for Soldering

- (1) In the case of flow soldering (Whole dipping is possible)

It is recommended that flow soldering should be at 270°C or less for 10 s or less
(Pre-heating : 100 to 150°C, 30 to 80s). (2 times or less)

- (2) In the case of hand soldering

What is done on the following condition is recommended. (2 times or less)

Soldering iron temperature : 400°C or less

Time : 3s or less

- (3) Other precautions

Depending on equipment and soldering conditions (temperature, Using solder etc.),
the effect to the device and the PCB is different.

Please confirm that there is no problem on the actual use conditions in advance.

- This specification shall be applied to photocoupler, Model No. PC923L as an option.
- Applicable Models (Business dealing name)
PC923LRYSZ0F
- The relevant models are the models approved by VDE according to DIN EN 60747-5-5. (Under preparation)

Approved Model No. : PC923L

VDE approved No. : 40008898 (According to the specification DIN EN60747-5-5)

- Operating isolation voltage V_{IORM} : 890V (Peak)
- Transient voltage : 7100V (Peak)
- Pollution : 2
- Clearances distance (Between input and output) : 6.4mm (MIN.)
- Creepage distance (Between input and output) : 6.4mm (MIN.)
- Tracking-proof : CTI 175
- Safety limit values
 - Current (Isi) : 200mA (Diode side)
 - Power (Psi) : 687mW (Photo IC side)
 - Temperature (Tsi) : 150°C

In order to keep safety electric isolation of photocoupler, please set the protective circuit to keep within safety limit values when the actual application equipment troubled.

- Indication of VDE approval "  " is printed on minimum unit package.

- Outline Refer to the attachment-2-2.

- Isolation specification according to EN60747-5-5

Parameter	Symbol	Condition	Rating	Unit	Remark									
Class of environmental test	-	-	55/100/21	-										
Pollution	-	-	2	-										
Maximum operating isolation voltage	V_{IORM} (PEAK)	-	890	V	Refer to the Diagram 1, 2 (Attachement-2-3)									
Partial discharge test voltage (Between input and output)														
<table border="1" style="width: 100%;"> <tr> <td>Diagram 1</td> <td>V_m</td> <td>$t_p=10s, q_c \leq 5pC$</td> <td>1430</td> <td>V</td> </tr> <tr> <td>Diagram 2</td> <td>(PEAK)</td> <td>$t_p=1s, q_c \leq 5pC$</td> <td>1670</td> <td>V</td> </tr> </table>	Diagram 1	V_m	$t_p=10s, q_c \leq 5pC$	1430		V	Diagram 2	(PEAK)	$t_p=1s, q_c \leq 5pC$	1670	V			
Diagram 1	V_m	$t_p=10s, q_c \leq 5pC$	1430	V										
Diagram 2	(PEAK)	$t_p=1s, q_c \leq 5pC$	1670	V										
Maximum over-voltage	$V_{ini,a}$ (PEAK)	$t_{NI}=60s$	7100	V										
Safety maximum ratings					Refer to Fig. 13, 14 (Attachement-2-3)									
1) Case temperature	T_{si}	$I_F=0, P_C=0$	150	°C										
2) Input current	I_{si}	$P_C=0$	200	mA										
3) Electric power (Output or Total power dissipation)	P_{si}	-	687	mW										
Isolation resistance (Test voltage between input and output ; DC500V)	R_{ISO}		$T_a=T_{si}$ MIN. 10^9	Ω										
			$T_a=100^\circ C$ MIN. 10^{11}											
			$T_a=25^\circ C$ MIN. 10^{12}											

- Precautions in performing isolation test

6.1 Partial discharge test methods shall be the ones according to the specifications of EN 60747-5-5

6.2 Please don't carry out isolation test (V_{iso}) over $V_{ini,a}$.

This product deteriorates isolation characteristics by partial discharge due to applying high voltage.

And there is possibility that partial discharge occurs in operating isolation voltage. (V_{IORM}).

4. Outline

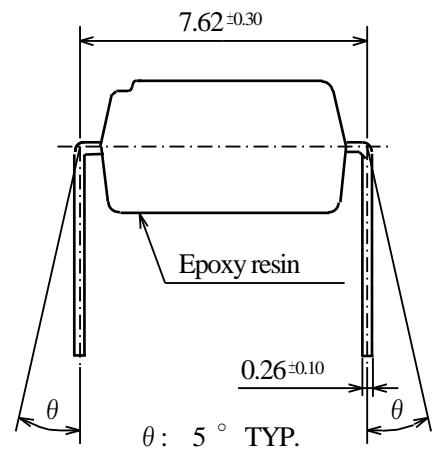
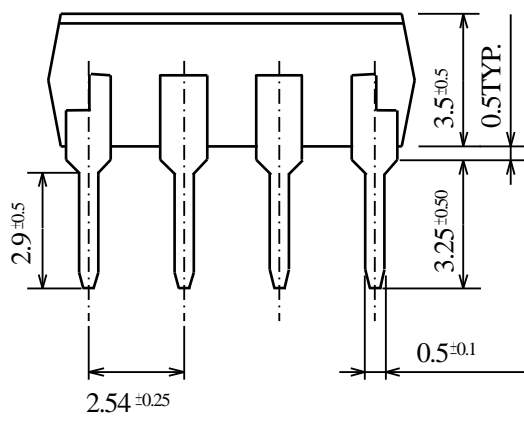
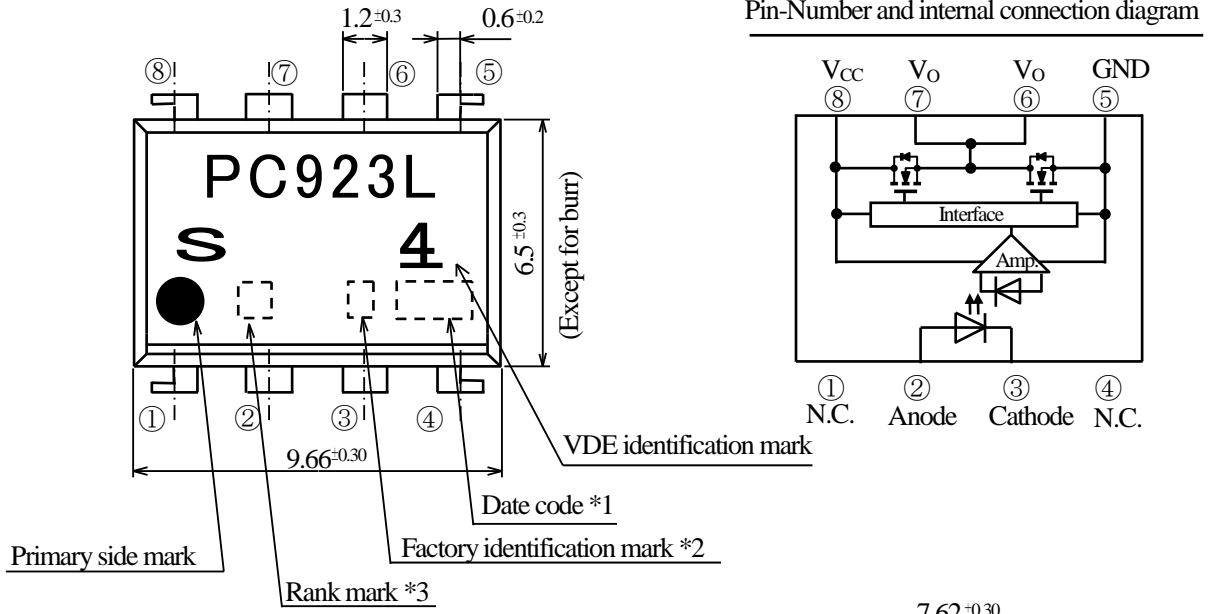

- *1 Date code : 3 digit indication according to production year, month and day
- *2 Factory identification mark is as follows.
H : YONGYAO ENSEI ELECTRONICS (SHANGQIU) CO., LTD. (CHINA products)
- *3 Rank mark shall be or shall not be marked.

Pin material: Copper Alloy
 Pin finish : Palladium (Au flash plating)
 Mark : Laser marking

Product mass: Approx. 0.55g

UNIT : 1/1 mm	
Name	PC923L Outline Dimensions (Business dealing name : PC923LRYSZ0F)

Method of Diagram 1: Breakdown test (Apply to type test and sampling test)

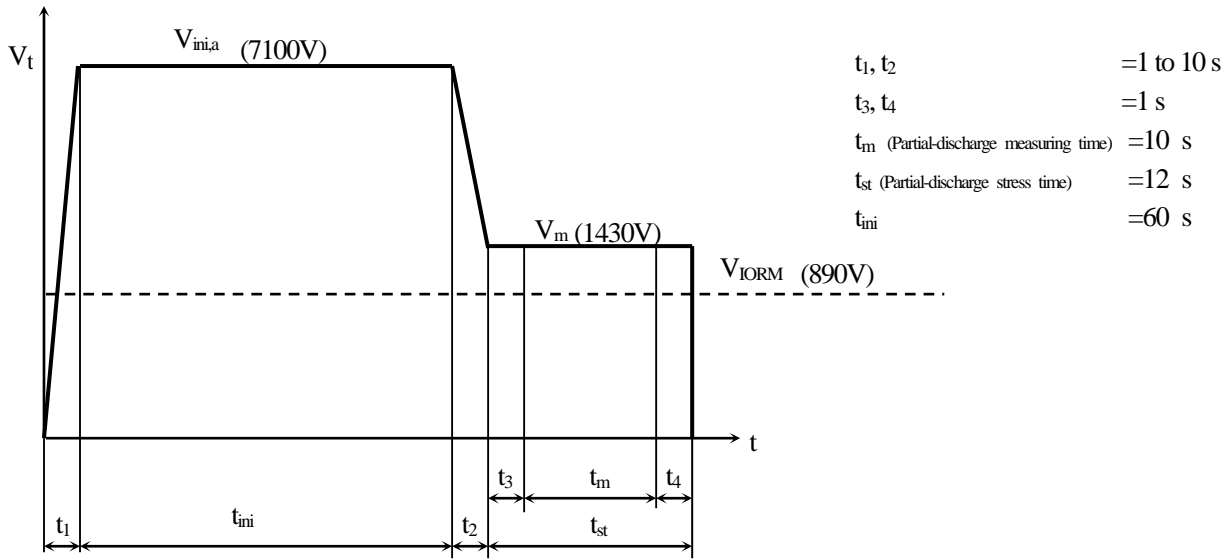

Method of Diagram 2: Non breakdown test (Apply to all device test)

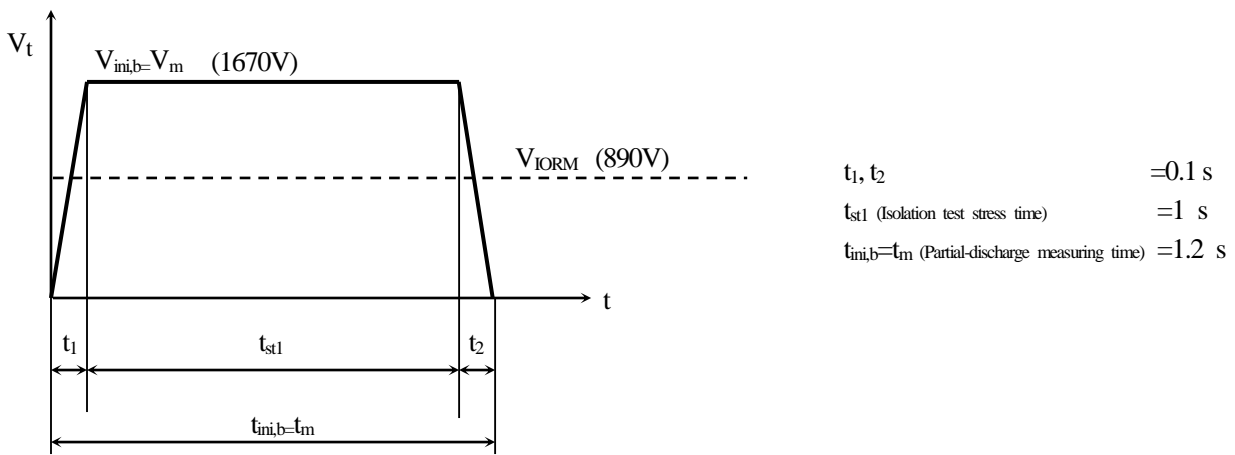

(Fig.13) Safety maximum power dissipation vs. ambient temperature (When failed)

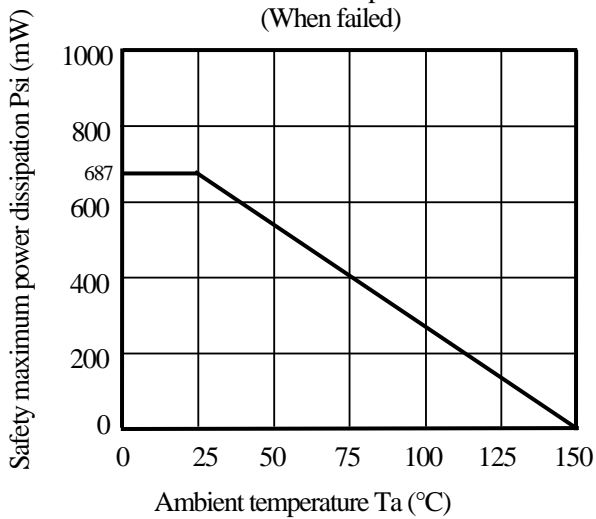

(Fig. 14) Safety maximum forward current vs. ambient temperature (When failed)

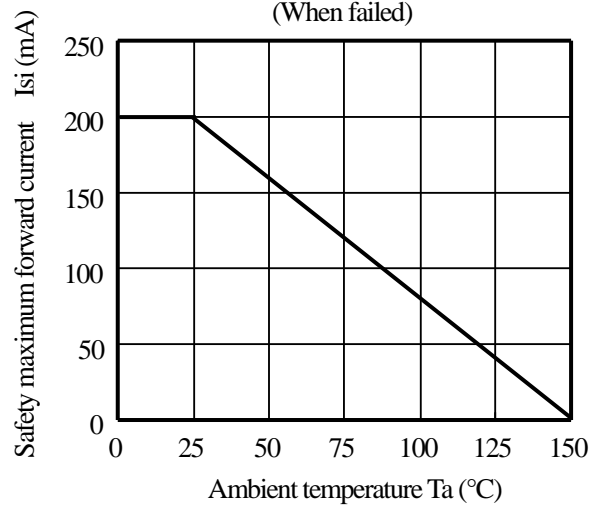

X-ON Electronics

Largest Supplier of Electrical and Electronic Components

Click to view similar products for [Logic Output Opto-couplers](#) category:

Click to view products by [Sharp](#) manufacturer:

Other Similar products are found below :

[CPC1590P](#) [TLP705A\(F\)](#) [VO3120-X019T](#) [TLP5772H\(TP4,E](#) [TLP5772H\(TP,E](#) [TLP5771H\(TP4,E](#) [TLP5771H\(D4,E](#) [TLP5774H\(D4,E](#)
[TLP5771H\(E](#) [TLP5772H\(D4LF4,E](#) [TLP5774H\(LF4,E](#) [TLP5771H\(D4LF4,E](#) [TLP5771H\(LF4,E](#) [TLP5214A\(E\(O](#) [FOD3125SD](#) [FOD8482T](#)
[LTV-3120S-TA1-H](#) [LTV-332J-TP1](#) [PC923LRNIP0F](#) [HCPL-0630-500E\(TOKMAS\)](#) [TLP719F\(D4-TP,F\)](#) [TLP5702\(D4-TP,E\(T](#)
[TLP105\(TPL,F\)](#) [TLP2301\(GB-TPL,E\(T](#) [TLP715\(D4-TP,F\)](#) [TLP2348\(TPL,E\(T](#) [6N137S](#) [KPC410 0E](#) [ELM600\(TA\)](#) [6N138M](#) [6N137M](#)
[ELS3120P\(TA\)-VG](#) [6N137-500E-JSM](#) [H11L1S-TA1-L](#) [CY4N33S\(TP1\)](#) [CY4N33](#) [PC923LRNSZ0F](#) [H11L1S\(TA\)](#) [H11L3SR2M](#) [HCPL-](#)
[0302-000E](#) [HCPL-6730](#) [HCPL-J312-000E](#) [LTV-3120S-TA1](#) [TLP155E\(TPL,E\)](#) [TLP2345\(E\(T](#) [TLP2348\(E\(T](#) [TLP350H\(F\)](#) [TLP5214\(E\(O](#)
[TLP701AF\(F\)](#) [5962-89785022A](#)