

PQ6CU11X1APQ

CMOS Step-up
Chopper Regulator

■ Features

- 1.High switching voltage :MAX.30V
(capable of driving max 4LEDs in series connection)
- 2.Switching current: 250mA
- 3.High frequency PWM control :1.2MHz
- 4.High efficiency(efficiency : 85%)
- 5.Built-in overheat, overcurrent protection functions
- 6.Built-in soft start function
- 7.RoHS directive compliant

■ Applications

- 1.Mobile phone
- 2.DSC
- 3.PDA

■ Absolute Maximum Ratings

(Ta=25°C)

Parameter	Symbol	Rating	Unit
Input voltage	V _{IN}	6	V
Output voltage	V _O	30	V
Switching voltage	V _{SW}	30	V
Control voltage	CTRL	V _{IN}	V
Feed back voltage	FB	6	V
Switching current	I _{SW}	250	mA
Power dissipation	P _d	350	mW
Junction temperature	T _j	150	°C
Operating temperature	T _{opr}	-40 to +85	°C
Storage temperature	T _{stg}	-40 to +150	°C
Soldering temperature	T _{sol}	260(10s)	°C

■ Operating conditions

Parameter	Symbol	Rating	Unit
Operating Junction temperature	T _j	-40 to +125	°C

■ Outline Dimensions

(Unit:mm)

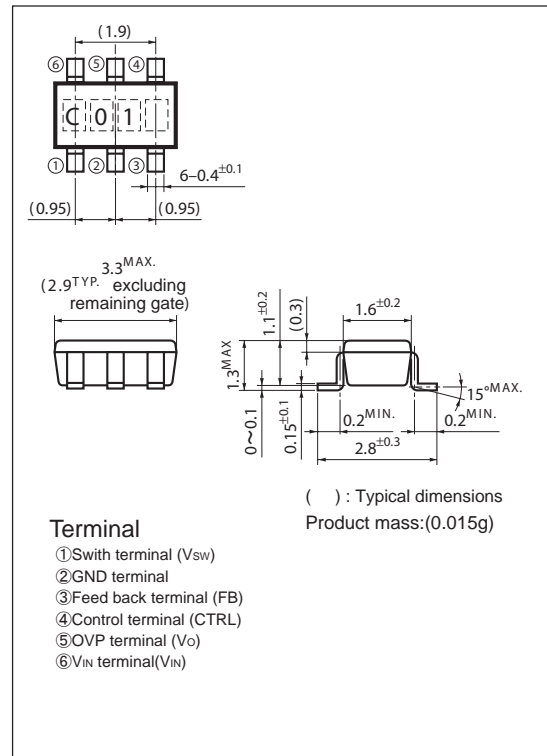

Terminal

- ① Switch terminal (V_{SW})
- ② GND terminal
- ③ Feed back terminal (FB)
- ④ Control terminal (CTRL)
- ⑤ OVP terminal (V_O)
- ⑥ V_{IN} terminal(V_{IN})

Lead finish:Lead-free solder plating
(Composition: Sn2Bi)

Notice The content of data sheet is subject to change without prior notice.

In the absence of confirmation by device specification sheets, SHARP takes no responsibility for any defects that may occur in equipment using any SHARP devices shown in catalogs, data books, etc. Contact SHARP in order to obtain the latest device specification sheets before using any SHARP device.

Electrical Characteristics

(Unless otherwise specified, condition shall be $V_{IN}=V_{CTRL}=3.6V, V_o=10V, I_o=20mA, T_a=25^{\circ}C$)

Parameter	Symbol	Conditions	MIN.	TYP.	MAX.	Unit
Input-output voltage range	V_{IN}	-	2.7	-	5.5	V
Overvoltage detecting level	OVP	5pin	26	28	30	V
Overvoltage detecting hysteresis level	OVP(hys)	5pin	-	2	-	V
Quiescent current	I_q	Switching, $I_o=0mA$	-	0.8	1.6	mA
Stand-by current	I_{SD}	$V_{CTRL}=0V$	-	0.1	1	μA
Efficiency	η	3 LEDs	-	90	-	%
Error amplifier						
Reference voltage	V_{REF}	-	86	95	104	mV
FB pin bias current	I_{FB}	-	-	30	100	nA
Oscillator						
Oscillation frequency	f_o	-	1	1.2	1.4	MHz
Maximum duty	D_{MAX}	$V_{IN}=3V$	85	-	-	%
Power switch						
Overcurrent detection level	I_L	DUTY=70%, Switching current peak	260	-	-	mA
On-resistance	R_{ON}	$I_{SW}=250mA$	-	1.7	2.5	Ω
Leakage current	I_{LEAK}	$V_{SW}=28V, V_{IN}=V_{CTRL}=0V$	-	0.05	1	μA
Control terminal						
ON-state voltage for control	$V_{C(ON)}$	-	1	-	-	V
OFF-state voltage for control	$V_{C(OFF)}$	-	-	-	0.4	V
CTRL pin bias current	I_{CTRL}	-	-	-	50	μA

Fig.1 Standard measuring circuit

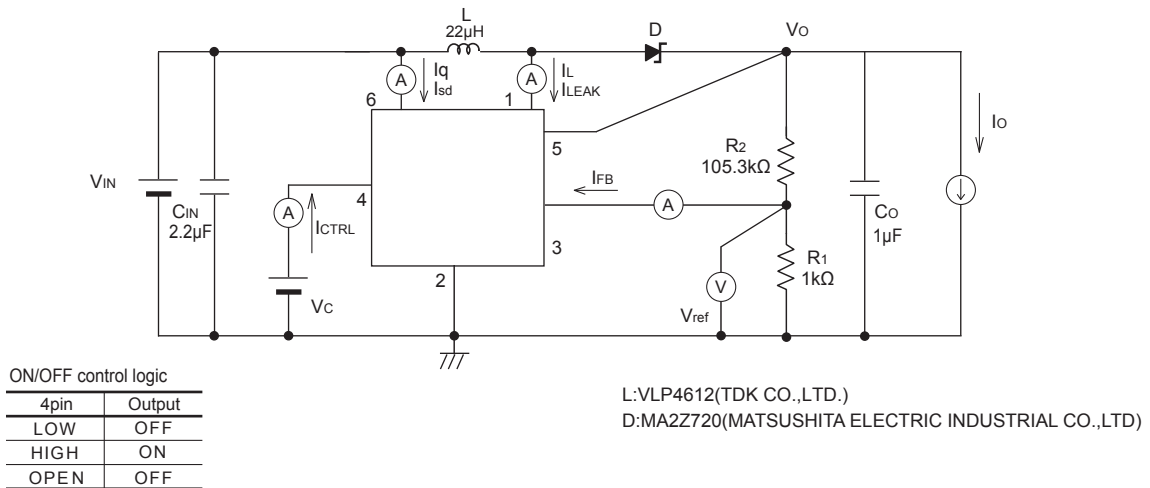

Fig.2 Power Dissipation vs. Ambient Temperature

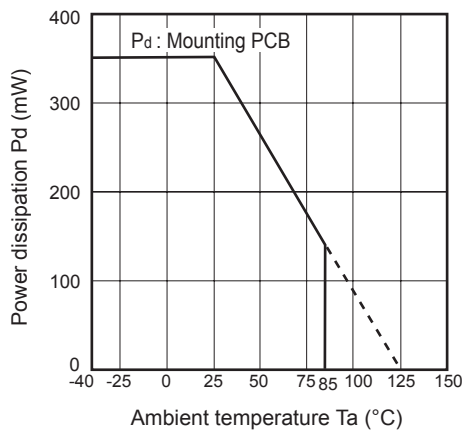

Fig.3 Reference Voltage Fluctuation vs. Junction Temperature

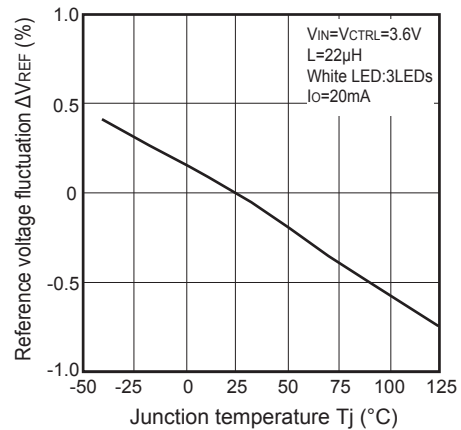

Fig.4 Reference Voltage Fluctuation vs. Input voltage

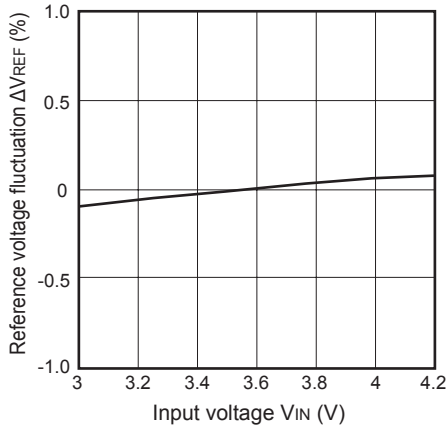

Fig.5 Efficiency vs. LED Current

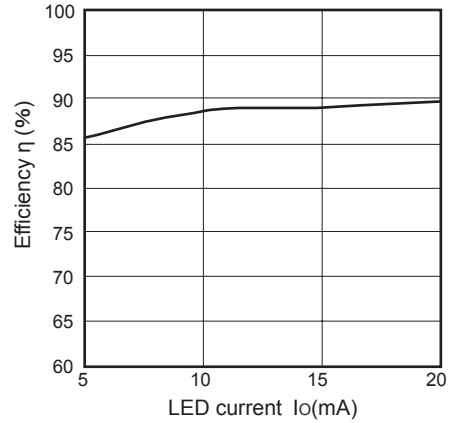

Fig.6 Efficiency vs. Input Voltage

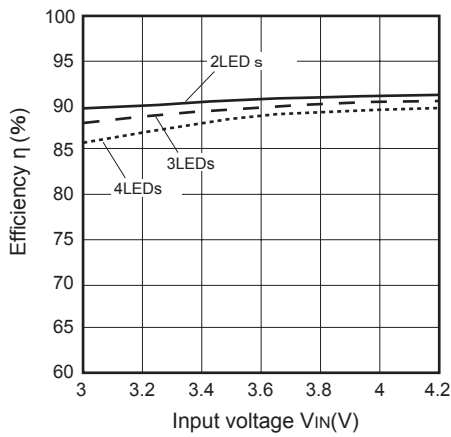

Fig.7 Oscillation Frequency Fluctuation vs. Junction Temperature

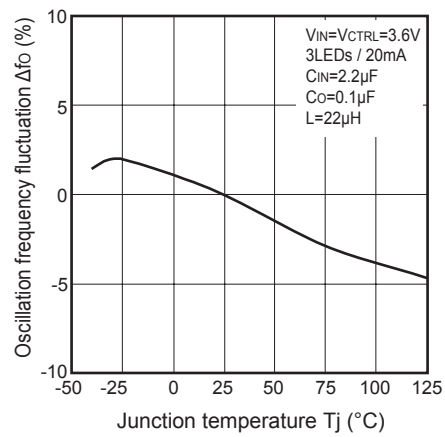

Fig.8 On-Resistance vs. Junction Temperature

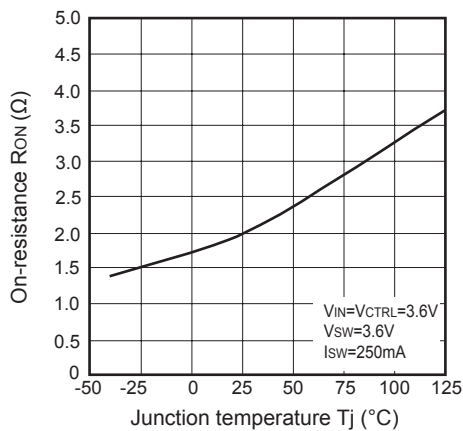
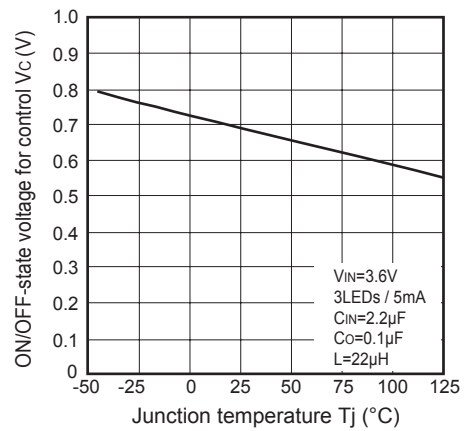
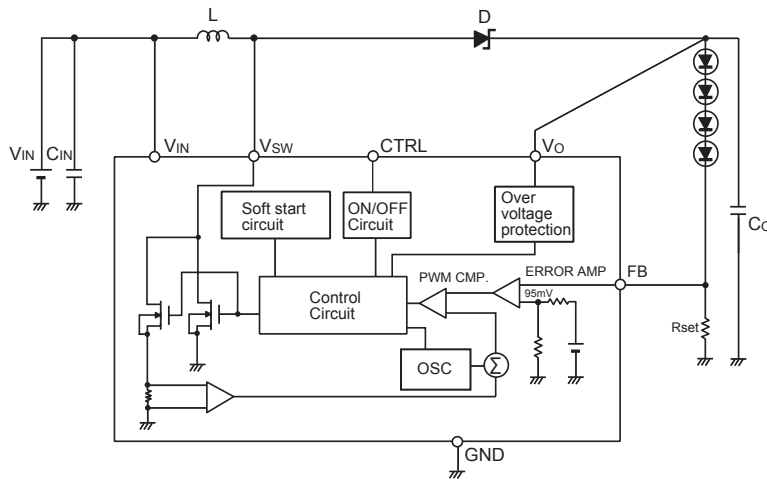

Fig.9 ON/OFF-state Voltage for Control vs. Junction Temperature



■ Block Diagram



■ Example of application

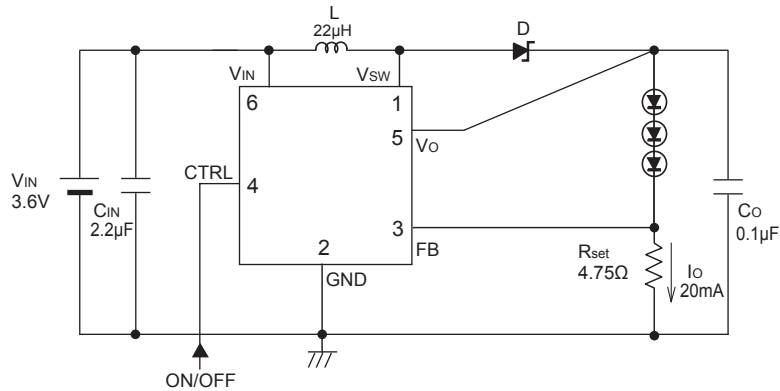

■ Current-limit

This product monitors the switch current at every cycle and limits the switch current not to exceed the overcurrent detection level.

Please set the white LED current under the maximum LED current shown in the graph indicated below within the range of input voltage (V_{IN}) you use.

Fig.10 Use Range of White LED

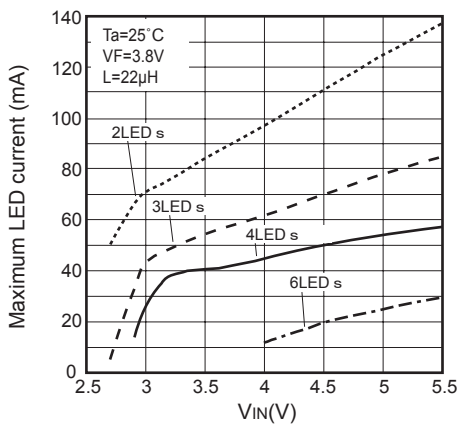

X-ON Electronics

Largest Supplier of Electrical and Electronic Components

Click to view similar products for [LED Lighting Drivers](#) category:

Click to view products by [Sharp](#) manufacturer:

Other Similar products are found below :

[LV5235V-MPB-H](#) [MB39C602PNF-G-JNEFE1](#) [FAN5701UMP20X](#) [FAN5702UMP30X](#) [MIC2871YMK-T5](#) [MP1518DJ-LF-P](#) [MP3202DG-LF-P](#) [MP3304BDD-LF-P](#) [MP3306EG-LF-P](#) [MP3398AGY](#) [MP4033GK](#) [AL1676-10BS7-13](#) [AL1676-20AS7-13](#) [MX877RTR](#)
[NCL30085BDR2G](#) [ICL8201](#) [IS31BL3506B-TTLS2-TR](#) [PAM2841GR](#) [A8519KLPTR-T](#) [FAN5701UMP08X](#) [FAN5702UMP20X](#) [AL3157F-7](#)
[AL8807BQMP-13](#) [LV52204MTTBG](#) [TLD1120EL](#) [MP2488DN-LF](#) [MP24893DQ-LF-P](#) [MP24894GJ-P](#) [MP24895GJ-P](#) [MP3308DL-LF-Z](#)
[MP3393EF-LF](#) [MP3394SGF](#) [MP3802DQ-LF-P](#) [MP4008GS](#) [MP4031GS](#) [MP4032-1GS](#) [MP4034GS](#) [MP46885DN-LF](#) [SLG7NT4082V](#)
[SLG7NT4082VTR](#) [PCA9955BTWQ900J](#) [TLD5095EL](#) [LED6001TR](#) [STP4CMPQTR](#) [BD1604MVV-E2](#) [MC10SX1130DG](#)
[MAX16832CASAT](#) [MAX16814CATP+](#) [NCL30086BDR2G](#) [NCL30088BDR2G](#)