



胜丰电子有限公司

APPROVAL SHEET

Customer :

Customer P/N: SF 4028B2H12V 3 线

Description: DC FAN

Model NO.: SF 4028B2H12V 3 线

Version.: A Issue NO.: 18SFH0901

Issue date: 2018-09-01 Quantity: 2PCS

*Please sign back this specification for our record upon your approval.

Thanks!

Company Stamp
.....
制作：黄梓洪
复核：田付安
核准：吴国旗

CUSTOMER APPROVAL Stamp
.....
承认：
核准：
日期：

地址：深圳市龙岗区坂田街道雅南路南坑第二工业区

电话：0755-82716358 82579709 传真：22636467

免费咨询和订购热线：**400-9920-988** 官方网站 <http://www.fancool.net/>

E-Mail: fancool18@163.com

1.0: 一般规格 (General Specification)

项目 (Item)		规格/条件 (Specification/Condition)	
1	型号 (Model No.)	SF 4028B2H12	
2	外型尺寸 (Outline Dimension)	40*40*28	
3	工作电压 (Operating Voltage)	DC 6.50-13.80V	
4	额定电压 (Rated voltage)	DC 12.0 V	
5	起动电压 (Starting Voltage)	DC ≤6.50V on/off	
6	额定电流 (Rated current)	0.33A	a. 额定电压(Rated .voltage) b.25°C 65% RH c.After testing for 5 minutes
7	消耗功率 (Power consumption)	3.96W	
8	转速 (Speed)	12000±10%RPM	
9	最大风量： (Max Airflow)	15.00CFM	a. 额定电压(Rated .voltage) b. AMCA 标准 (Standard) C. 额定电流(Rated current)
	最大静压： (Air .Static Pressure)	16.84mmAq	
10	最大噪音 (Max Noise)	Max:43.30Db-A	a. 额定电压 (Rated Voltage) b. 18dB无响室 (18dB Non-Echo Chamber) c. 标准 (Standard):CNS 8753 / ISO 3744 d. Test Condition :ISO 7779

			e. 距离 (Distance): 1.0 M
11	Life expectancy(期望寿命)	50000 hrs at temp 25°C Humidity5%-95%	MTTF (Mean Time To Failure) Conf. Level 90%)
12	扇叶数 (No.of.Blade)	5 叶	
13	极数 (No.of.Pole)	4 极	
14	运转方向 (Rotating Direction)	逆时针/运转方向是从扇叶面看	
15	锁住保护 Lock Protection	有 YES 1. 额定电压堵住 2-3 秒，自动断电。降低内部温升 (Auto power off after locked at rated voltage for 2-3 sec. Reduce internal temperature rise) 2. 自动断电后，2 至 6 秒自动尝试启动。 (After auto power off, circuit attempt to restart in 2 to 6 sec.)	
16	极性保护 Polarity Protection	<input type="checkbox"/> 无 NO	
17	过压保护 (Over voltage protect)	<input type="checkbox"/> 无 NO	
18	过流保护 (Overcurrent protection)	<input type="checkbox"/> 无 NO	
19	FG 功能 (FG function)	转速反馈 Tachometer Output	

2.0:主要材料/零件规格 (Main Materials/parts Specification)

材料/零件 (Materials/parts)		规格(Specification)		
1	塑料材料/扇叶 外框 (Plastic Material/Blade, Housing)	PBT 黑色方框 5 叶		
2	轴承 (Bearing Type)	滚珠轴承 (Ball Bearing)		
3	引线 (Lead Wire)	UL1007#24#330mm 红黑黄分线 锡头外露 5MM		
4	端子 (Connector)	红(VCC)	黑 (GND)	黄 (FG)

3.0 電性規格 (Electrical Specifically)

1	絕緣阻抗 Insulation Resistance	10MΩ/裸線与外框間測量，500VDC/min 10MΩ/between unshackled wire and frame at 500VDC/min
2	絕緣耐压 Dielectric Strength	5Ma Max./導線与外框間測量，500VAC/min 5Ma Max./Measured between lead wire(+)and frame at 500VAC/min
3	防水等级 Waterproof level	IP X0

4.0 环境测试 (Environmental Specification)

1	运转温/湿度范围 Operating Temp .Range	温度/Temperature:-10°C - +70°C 湿度/Humidity:5% - 95%RH
2	保存温/湿度范围 Storage Temperature	温度/Temperature:-40°C - +75°C 湿度/Humidity:5% - 95%RH
3	耐湿性 Humidity	电气规格依据 MIL-STD 202F Method 103B 湿度：95%RH 温度：40±2°C
4	热冲击 Thermal Shock	电气规格依据 MIL-STD 202F Method 107D Per MIL-STD 202F Method 107D,Condition D
5	绝缘阶段 Insulation Shock	UL: A 种 UL : Class A
6	包装耐振动试验 Packing Vibration Test	包装后，XYZ 三方向施 1.1G load vibration test for 30min .No serious damage
7	包装耐冲击试验 Packing Shock Proof Test	捆包后，高 60 公分，1 棱角 3 边 6 面自然落下，无严重损坏。 1comer,3edges, 6faces natural drop from 60cm high packing No serious damage

5.0 在无响室额定电压下之噪音测试

(NOISE IS MEASURED AT RATED VOLTAGE IN ANECHOIC)

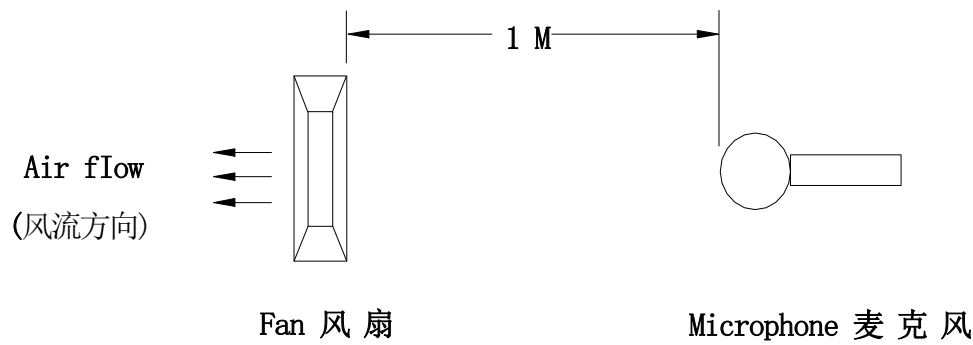

(在背景噪音不超过 18dB (A) 的无响室内, 将待测风扇通入额定的工作电压, 悬掉入空中, 将麦克风放于风扇同一平面且离待测风扇进风口一米处进行测试其 B&K 值)

Noise is measured rated voltage in free air in anechoic chamber with B&K sound level meter with microphone at a distance of one meter from the fan intake. The background noise is 18Db(A) max.

6.0 平均寿命说明 (Life Expectancy Explanation)

在指定恒温下持续工作后, 经检验, 90%能正常运转即可估算其平均使用寿命(The continuous duty life at given temperature after which, 90% of testing units shall still be running)。

Bearing System	Test Temperature	Test time (H)
Two ball Bearing	25°C	50000
Two ball Bearing	40°C	42000
Two ball Bearing	60°C	30000

5.0 在无响室额定电压下之噪音测试

(NOISE IS MEASURED AT RATED VOLTAGE IN ANECHOIC)

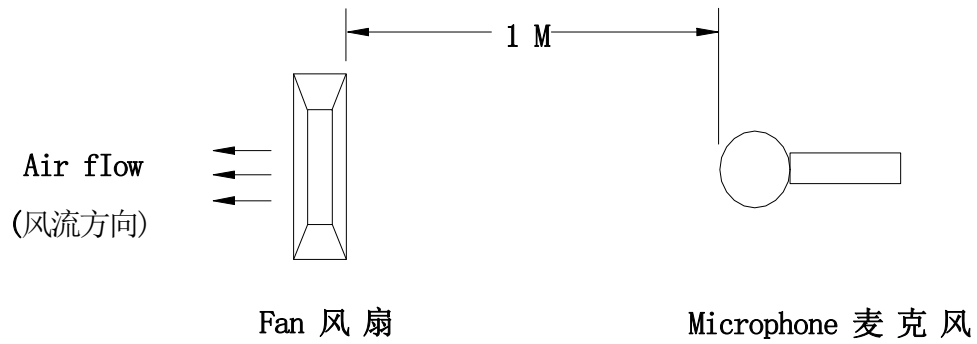

(在背景噪音不超过 18dB (A) 的无响室内, 将待测风扇通入额定的工作电压, 悬掉入空中, 将麦克风放于风扇同一平面且离待测风扇进风口一米处进行测试其 B&K 值)

Noise is measured rated voltage in free air in anechoic chamber with B&K sound level meter with microphone at a distance of one meter from the fan intake. The background noise is 18Db(A) max.

6.0 风扇框叶图

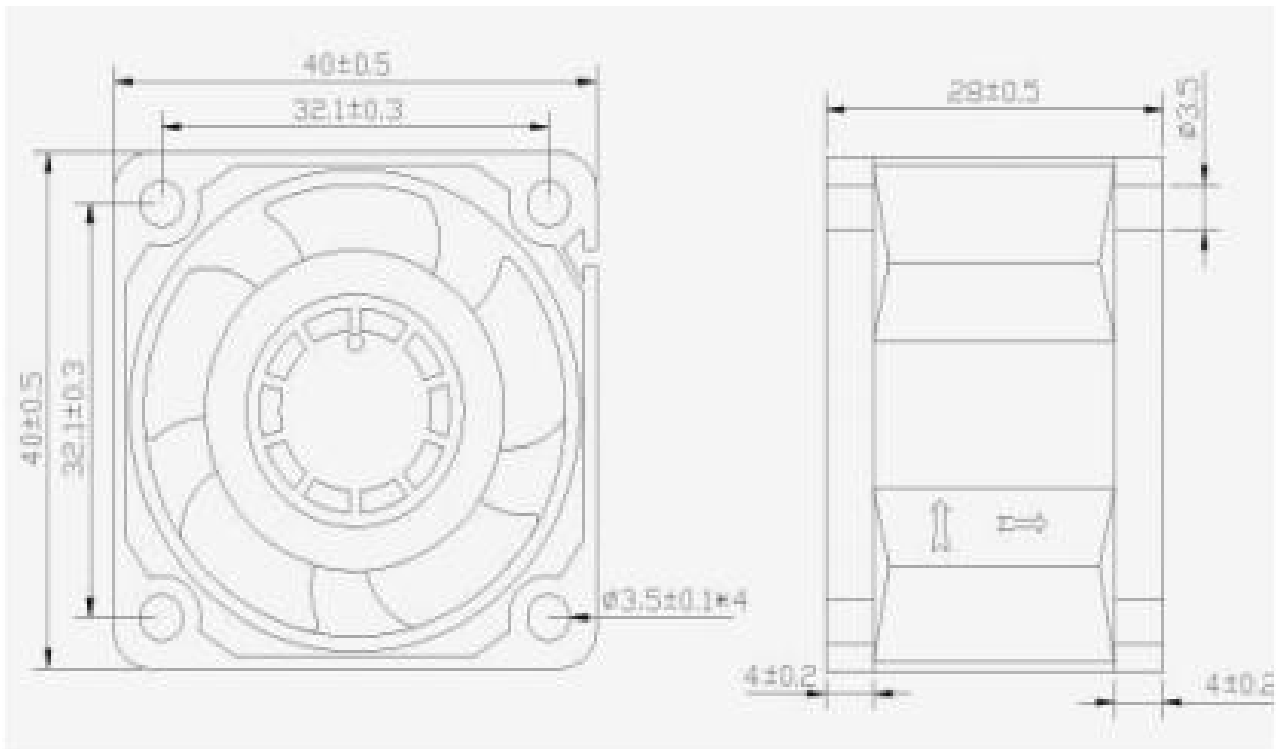

胜丰电子有限公司

SHENGFENG ELECTRONICS CO.,LTD

400-9920-988

制图：陈卿伟

www.fancool.net

审核：陈惠

注意事项 (NOTES)

1 Before use, make sure the supply voltage to meet the use of the product range, line-powered load exceeds the maximum power consumption of this product 120%.

And the voltage is stable without clutter

(使用前, 确认供电电压能满足本产品的使用范围, 供电电路负载超过本产品的最大功耗的 120%。且电压是稳定不含杂波干扰)

2 Please when ventilator circular telegram normal work do not use the hand to bump touches fan blade border

(请在风扇通电正常运转时不要用手碰触扇叶边沿)

3 Please do not touch the impeller and never carry the fan the lead wires. The bearings and the lead wires may be damaged. Additionally, static electricity may damage the internal circuits of the fan

(请不要碰触扇叶和拉扯线材, 以免损坏轴承及导线。此外, 静电可能损坏内部的风扇元件)

4 Please do not use the fan in the environment of corrosive gas or liquid.

(请不要将风扇置于腐蚀的气体和液体内)

5 Please do not store the an in the environmet of high humidity. Please avoid storage of the fan over 6months. For long term storage, please connect power to the fan shortly every 6 months even through the fan is stored in room temperature.

(请不要将风扇储存在高湿度的环境中, 请尽量避免将风扇储存期超过 6 个月。如果要长期储存, 请将其在室温的环境下。且每隔 6 个月须上电源让风扇短时间运转。)

Shenzhen BCTC Testing Co., Ltd.

BCTC Building & 1-2F, East of B Building, Pengzhou Industrial, Fuyuan 1st Road,
Qiaotou Community, Fuyong Street, Bao'an District, Shenzhen, China



Certificate of Compliance

Applicant : SHENGFENGHONG ELECTRONICS CO.,LTD.
No.1-2205 Yabao Rd., Bantian, Longgang Distict, Shenzhen, China

Manufacturer : SHENGFENGHONG ELECTRONICS CO.,LTD.
No.1-2205 Yabao Rd., Bantian, Longgang Distict, Shenzhen, China

Product : Draught fan*cooling fan
M/N : 12032 DC48V B2 BLOWER
SFH12032, SFH1504, SFH1805, SFH2006, SFH2010, SFH2507, SFH2510,
SFH3007, SFH3010, SFH3020, SFH3507, SFH3510, SFH4007, SFH4010,
SFH4015, SFH4020, SFH4028, SFH4056, SFH5010, SFH5012, SFH5015,
SFH5020, SFH5025, SFH6010, SFH6015, SFH6020, SFH6025, SFH6038,
SFH7010, SFH7015, SFH7020, SFH7025, SHF7030, SFH7038, SFH7530,
SFH8010, SFH8015, SFH8020, SFH8025, SFH8038, SFH9010, SFH9015,
SFH9020, SFH9025, SFH9038, SFH9210, SFH9215, SFH9220, SFH9225,
SFH9238, SFH10025, SFH11025, SFH12025, SFH12038, SFH14025,
SFH14038, SFH15050, SFH16050, SFH17238, SFH17251, SFH18060,
SFH20060, SFH22060, SFH25489

Test Standard : EN 55032: 2015, EN 55035:2017
EN 61000-3-2:2014, EN 61000-3-3:2013

Order No. / Report No. : BCTC-LH180601620C/BCTC-LH180601620E

The EUT described above has been tested according to the listed standards and found in compliance with the council EMC directive 2014/30/EU. The observations and test results referenced from this Certificate are relevant only to the sample tested. This Certificate is for the exclusive use of BCTC's Client and is provided pursuant to the agreement between BCTC and its Client. This Certificate is part of the full test report(s) and should be read in conjunction with it.



This certificate of conformity is based on a single evaluation of the submitted sample(s) of the above mentioned product. It does not imply an assessment of the whole product and relevant. Directives have to be observed.

Tel: 400-788-9558 0755-33019988
Http://www.bctc-lab.com Http://www.bctc-lab.com.cn



Shenzhen BCTC Testing Co., Ltd.

BCTC Building & 1-2F, East of B Building, Pengzhou Industrial, Fuyuan 1st Road,
Qiaotou Community, Fuyong Street, Bao'an District, Shenzhen, China



Verification of Conformity

Certificate Number: BCTC-LH180601621C

We herewith confirm the following designated product:

Applicant : SHENGFENGHONG ELECTRONICS CO.,LTD.
No.1-2205 Yabao Rd., Bantian, Longgang Distict, Shenzhen, China

Manufacturer : SHENGFENGHONG ELECTRONICS CO.,LTD.
No.1-2205 Yabao Rd., Bantian, Longgang Distict, Shenzhen, China

Product : Draught fan*cooling fan
M/N : 12032 DC48V B2 BLOWER
SFH12032, SFH1504, SFH1805, SFH2006, SFH2010, SFH2507, SFH2510,
SFH3007, SFH3010, SFH3020, SFH3507, SFH3510, SFH4007, SFH4010, SFH4015,
SFH4020, SFH4028, SFH4056, SFH5010, SFH5012, SFH5015, SFH5020, SFH5025,
SFH6010, SFH6015, SFH6020, SFH6025, SFH6038, SFH7010, SFH7015, SFH7020,
SFH7025, SHF7030, SFH7038, SFH7530, SFH8010, SFH8015, SFH8020, SFH8025,
SFH8038, SFH9010, SFH9015, SFH9020, SFH9025, SFH9038, SFH9210, SFH9215,
SFH9220, SFH9225, SFH9238, SFH10025, SFH11025, SFH12025, SFH12038,
SFH14025, SFH14038, SFH15050, SFH16050, SFH17238, SFH17251, SFH18060,
SFH20060, SFH22060, SFH25489

The submitted sample of the above equipment has been tested and found to comply with the following standards:

- FCC Part 15, Subpart B
- ANSI C63.4: 2014

This verification is part of the full test report(s) and should be read in conjunction with it. The referred Test report(s) show that the product complies with standard(s) recognized as giving presumption of compliance with the essential requirements in the specified FCC standard.

This Verification does not imply assessment of the production of the product.



This certificate of conformity is based on a single evaluation of the submitted sample(s) of the above mentioned product. It does not imply an assessment of the whole product and relevant. Directives have to be observed.

Tel: 400-788-9558 0755-33019988
Http://www.bctc-lab.com Http://www.bctc-lab.com.cn



X-ON Electronics

Largest Supplier of Electrical and Electronic Components

Click to view similar products for [AC Fans](#) category:

Click to view products by [SHENG FENG](#) manufacturer:

Other Similar products are found below :

[8850A](#) [A2D200-AA04-41](#) [A2E165-AA17-01](#) [AC430019H-012](#) [144LS-2282-010](#) [1500-FAN-01](#) [25.350.5253.0](#) [S2E250-AL06-70](#) [A2D210-AB10-05](#) [A2D240-AA02-02](#) [23241-3](#) [25.345.5353.0](#) [281DY-1LP14-000B](#) [344DY-1LP11-000](#) [39.703.0253.0](#) [USTF1203224VHW](#)
[3915100996-SA3](#) [3G2C7MC224](#) [W2D200-HH04-07](#) [W2S130-AA03-43](#) [S2E250-BB13-22](#) [8856N](#) [A2E170-AF23-11](#) [W4S250-CA20-56](#)
[W2S130-AB03-09](#) [5900](#) [C45-A7](#) [TAC12025230MT](#) [8550A](#) [8560N](#) [AD0405HB-G73\(9T\)](#) [CENT-2000-FFTM](#) [CENT-2000-RFTM](#) [W2D200-CA04-52](#) [W2S130-AB25-10](#) [A4E330-AB18-09](#) [W2E250-DB05-52](#) [W4E315-CS22-70](#) [W2E300-CP02-75](#) [S4S250-BA02-20](#) [S2D300-BP02-37](#) [W2S130-AB25-24](#) [W2D250-GA08-08](#) [A2E200-AH38-70](#) [TAC8025115HW](#) [F1238H24BT-FHR](#) [S2D300-CP02-34](#) [4118N/2H8PU-011](#)
[RLF100-1114-060](#) [AD3512MB-G5B](#)