



High speed, Low dropout, $\pm 2\%$ High output accuracy with On/Off circuit CMOS Voltage Regulator

Features

- Output voltage range: **0.8V~5.0V (selectable with a step of 0.05V)**
- Operating voltage range: **1.6V~6.0V**
- High accuracy output voltage: **$\pm 2\%$ ($V_{OUT} = 1.95V \sim 5.0V$) / $\pm 40mV$ ($V_{OUT} = 0.8V \sim 1.9V$)**
- Maximum output current: **300mA**
- Dropout voltage: **Typ. 90mV ($V_{OUT} = 3.0V, I_{OUT} = 100mA$)**
- Low current consumption: **Typ. 25 μ A**
- High ripple rejection: **Typ. 50dB at 1KHz**
- Low ESR capacitor: **1.0 μ F ceramic capacitor**
- Operating temperature range: **-40°C ~ +85°C**
- Built-in over-current protector: **300mA limited**
- Small package: SOT23; SOT23-5L; SOT23-6L; SOT89-3L; DFN 1*1-4L
- C_L high-speed auto-discharge
- Built-in On/Off circuit
- Pb free & RoHS Compliant

Description

The JY1103 series are positive voltage regulators with high speed, low voltage dropout and high accuracy output achieved by low current consumption. The output voltage is guaranteed within $\pm 2\%$ within the given temperature range by V_{ref} controlling the temperature characteristic. It corresponds to the low ESR capacitor as an output stabilization capacitor. The charged ESR capacitor can be discharged with an internal switch by making the $EN=V_{SS}$, as a result the V_{OUT} quickly returns to the V_{SS} level. To make the current capacity of the output transistor not exceeded, the over-current protection circuit is built in.

Applications

- Battery powered devices
- Cellular phone
- Digital / Video cameras
- Portable games
- Handheld instruments
- Wireless LANs
- Bluetooth Portable Radios
- GSM/GPRS/3G RF Transceiver

Typical Application Circuitry

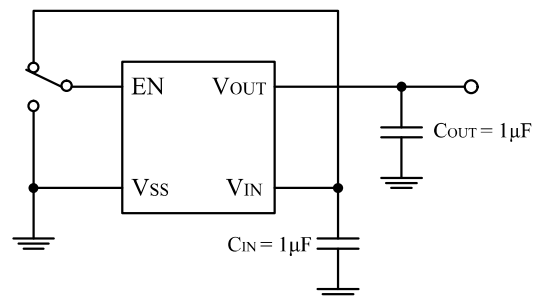



Pin Configuration & Marking Specification

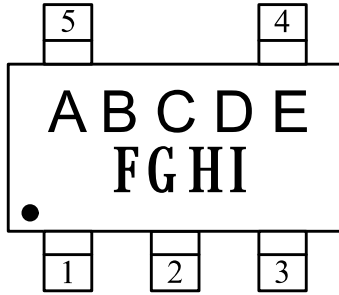

(SOT23-5L)

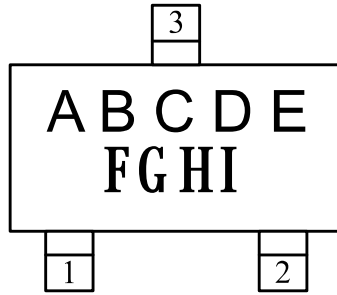

(SOT23)

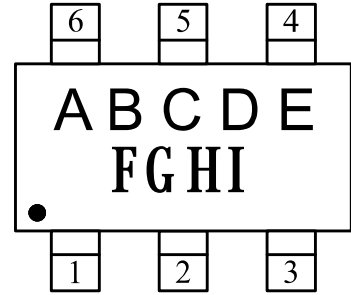

(SOT23-6L)

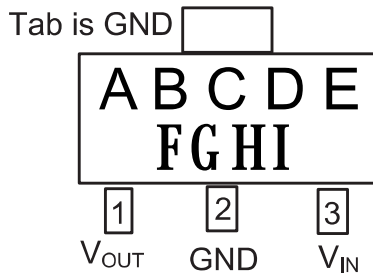

(SOT89-3L)

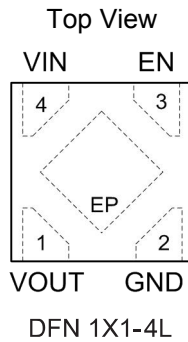

- Pin Configuration

SOT89-3L Pin No.	DFN 1X1 Pin No.	SOT23 Pin No.	SOT23-5L Pin No.	SOT23-6L Pin No.	Symbol	Description
3	4	3	1	1	V _{IN}	Voltage input
2	2	1	2	2	GND	Power ground
	3		3	3	EN	Chip enable
				4	NC	Non connection
				5	NC	Non connection
1	1	2	5	6	V _{OUT}	Output



- **Marking Specification**

Code	Marking	Contents
A	H/L	Function specification
BCD	090~500	Output voltage
E	A/B/C/F	Package type
F G	Year Code	Assembly year (last two number)
H I	Week Code	Assembly week in a year

(1)

Code	Marking	Contents
A	H/L	Function specification
BCD	090~500	Output voltage
E	A/B/C/F	Package type
F G H	Wafer Code	Wafer's Lot No
I	Internal Code	Internal Code

(2)

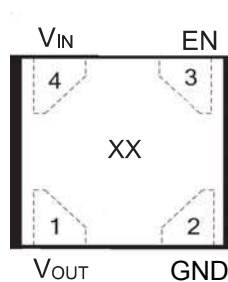

DFN1X1-4L

XX: 08-50 output voltage

08:0.8V,12:1.2V,18:1.8V,50:5.0V



Products Numbering Guide

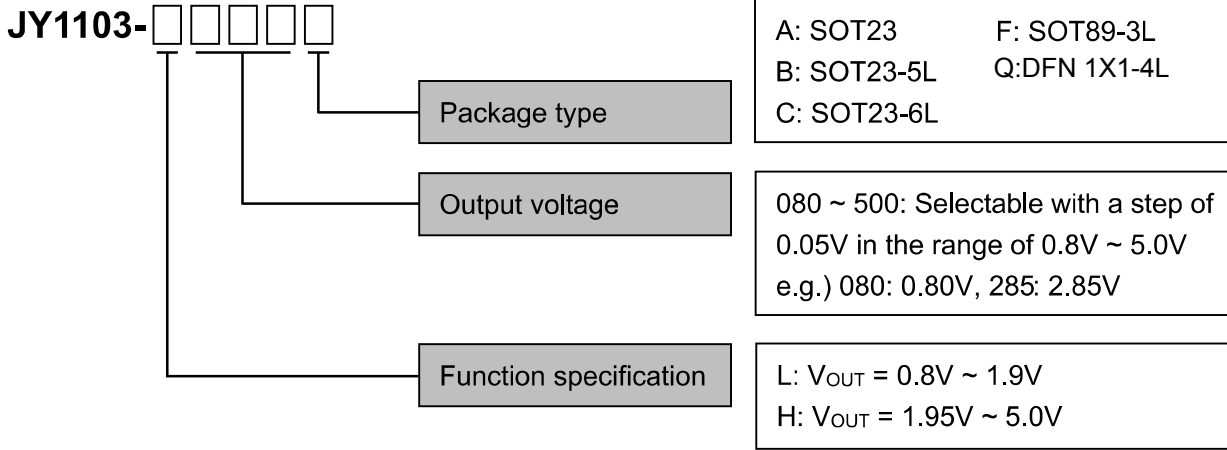

Part name	Packing	Quantity Per Reel
JY1103	SOT23-3	3000
	SOT89-3L	3000
	SOT23-5/6L	3000
	DFN 1X1-4L	10000



Circuit Diagram

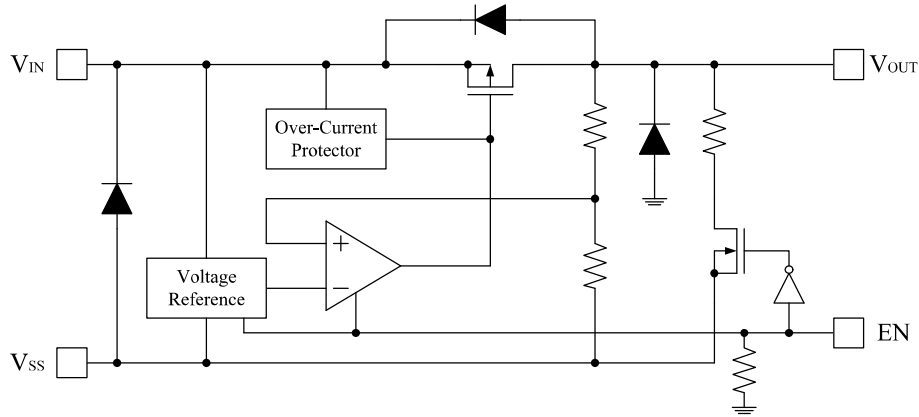

Absolute Maximum Rating

Symbol	Parameter	Value	Unit
V_{IN}	Input Voltage	-0.3 ~ +7.0	V
I_{OUT}	Output Current	300	mA
V_{OUT}	Output Voltage	$V_{SS} - 0.3 \sim V_{IN} + 0.3$	V
P_D	Power Dissipation ⁽¹⁾	400	mW
T_{Lead}	Lead Temperature(Soldering,10 Seconds)	260	°C
T_{OPT}	Operating Temperature	-40 ~ +85	°C
T_{STG}	Storage Temperature	-55 ~ +125	°C

Note:

(1) Power dissipation depends on conditions of mounting on boards.

PCB dimension is 50mm×50mm×1.6mm.



Electrical Characteristics

(T=25°C, unless otherwise specified)

Symbol	Parameter	Test Condition		Min.	Typ.	Max.	Unit	Test Circuit
V _{OUT}	Output voltage	V _{OUT} + 1.0V ≤ V _{IN} ≤ 6.0V I _{OUT} = 30mA T = -40°C ~ +80°C	V _{OUT} ≥ 1.95V	V _{OUT} × 0.99	V _{OUT}	V _{OUT} × 1.01	V	1
			V _{OUT} ≤ 1.90V	-20		+20	mV	
I _{OUT}	Output current	V _{IN} ≥ V _{OUT} + 1.0V	0.8V ≤ V _{OUT} ≤ 1.15V		300		mA	1
			1.2V ≤ V _{OUT} ≤ 1.65V		300		mA	
			1.7V ≤ V _{OUT} ≤ 2.25V		300		mA	
			2.3V ≤ V _{OUT} ≤ 2.85V		300		mA	
			2.9V ≤ V _{OUT} ≤ 3.45V		300		mA	
			3.5V ≤ V _{OUT} ≤ 4.05V		300		mA	
			4.0V ≤ V _{OUT} ≤ 5.00V		300		mA	
V _{DROP}	Dropout Voltage	I _{OUT} = 100mA	0.8V ≤ V _{OUT} ≤ 1.15V		480	730	mV	
			1.2V ≤ V _{OUT} ≤ 1.65V		210	340	mV	
			1.7V ≤ V _{OUT} ≤ 2.25V		130	205	mV	
			2.3V ≤ V _{OUT} ≤ 2.85V		100	150	mV	
			2.9V ≤ V _{OUT} ≤ 3.45V		90	137	mV	
			3.5V ≤ V _{OUT} ≤ 4.05V		85	115	mV	
			4.0V ≤ V _{OUT} ≤ 5.00V		80	85	mV	



Electrical Characteristics (Continued)

(T=25°C, unless otherwise specified)

Symbol	Parameter	Test Condition	Min.	Typ.	Max.	Unit	Test Circuit
I _{DD}	Current consumption	V _{IN} = V _{OUT} + 1.0V, V _{OUT} = Open, I _{OUT} = 0mA		25	40	μA	2
I _{STB}	Standby current	EN = V _{SS}		0.01	0.1	μA	2
V _{IN}	Input voltage		1.6		6.0	V	1
ΔV _{OUT}	Load regulation	V _{IN} = V _{OUT} + 1.0V, I _{OUT} = 0.1mA ~ 100mA		10	40	mV	1
$\frac{\Delta V_{OUT}}{\Delta V_{IN} \cdot V_{OUT}}$	Line regulation	V _{OUT} + 1.0V ≤ V _{IN} ≤ 6.0V, I _{OUT} = 30mA		0.01	0.2	%/V	1
R _r	Ripple rejection	V _{IN} = V _{OUT} + 1.0V, f = 1KHz, ΔV _{RIP} = 0.5V _{P-P} , I _{OUT} = 30mA		50		dB	3
I _{LIMIT}	Limit current	EN = V _{IN}	300			mA	1
I _{SHORT}	Short circuit current	V _{IN} = V _{OUT} + 1.0V, V _{OUT} = 0V		100		mA	1
$\frac{\Delta V_{OUT}}{\Delta T_a \cdot V_{OUT}}$	Output voltage temperature coefficient	V _{EN} = V _{IN} , I _{OUT} = 300mA, T _a = -40°C ~ +85°C		±20		ppm/°C	1
V _{ENH}	EN high level voltage		1.2		6.0	V	4
V _{ENL}	EN low level voltage				0.3	V	4
I _{ENH}	EN high level current	V _{EN} = V _{IN}	-0.1		0.1	μA	4
I _{ENL}	EN low level current	V _{EN} = V _{SS}	-0.1		0.1	μA	4
R _{DIS}	C _L auto-discharge resistance	V _{IN} = 6.0V, V _{OUT} = 4.0V, V _{EN} = V _{SS}		160		Ω	1



Test Circuits

- **Circuit (1):** Output voltage, Output current, Dropout voltage, Input voltage, Load regulation, Line regulation, Limit current, Short circuit current, Output voltage temperature coefficient, CL auto-discharge resistance

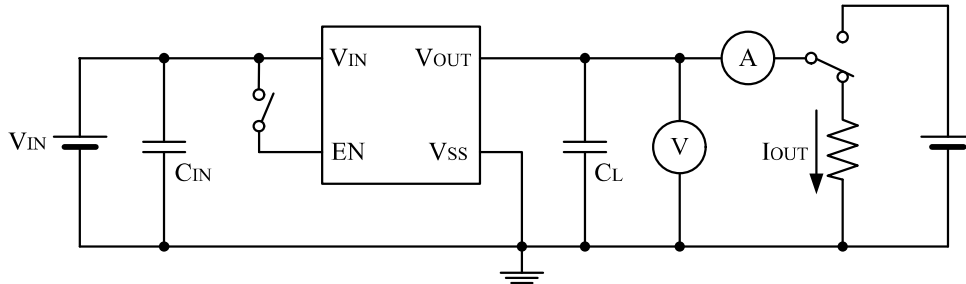

- **Circuit (2):** Output Current consumption, Standby current

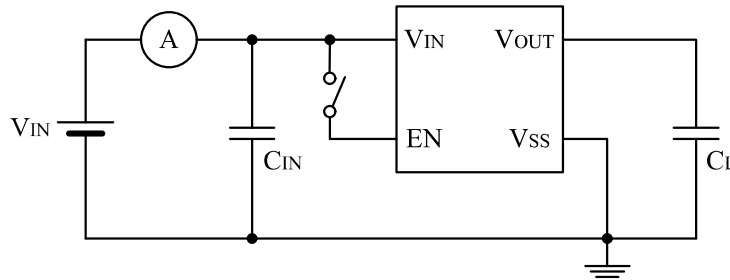

- **Circuit (3):** Ripple rejection

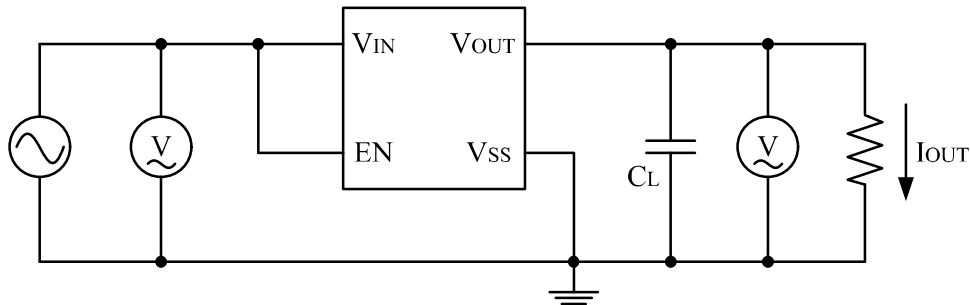

- **Circuit (4):** EN high level voltage, EN low level voltage, EN high level current, EN low level current

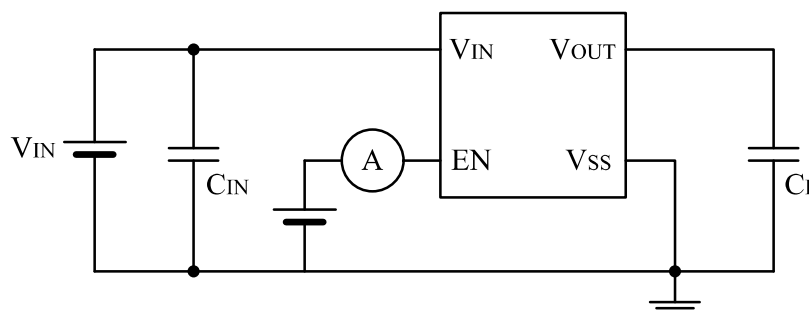



Description of Operation

- **General Operation**

In reference to following block diagram of the JY1103 series

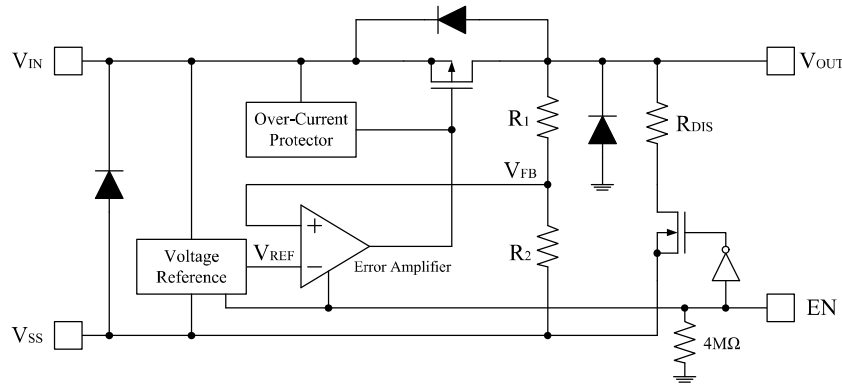

By the error amplifier, the reference voltage (V_{REF}) is compared with V_{FB} , which is divided by feedback resistors R_1 and R_2 . It supplies the output transistor to keep a stabilized output voltage against with any fluctuation of input voltage by negative feedback system.

The JY1103 series has P-channel MOSFET which is connected to the V_{OUT} terminal as the output transistor. To prevent the JY1103 series from being damaged due to inverse current from V_{OUT} terminal to V_{IN} terminal through a parasitic diode, V_{OUT} should not be exceeded $V_{IN} + 0.3V$.

- **EN terminal (shutdown function) & C_L auto-discharge**

The JY1103 series can be shutdown through EN terminal. The P-channel MOSFET is turned off and operation of all internal circuits stops to reduce the current consumption when the signal of EN terminal is set to the shutdown level. In shutdown mode, the JY1103 series enables the electric charge at the C_L to be discharged via the auto-discharge resistance ($R_{DIS} = 160\Omega$), and the V_{OUT} terminal can be rapidly returned to the V_{SS} level as a result.

- **Output capacitor (C_L)**

For phase compensation, an output capacitor (C_L) is required to connected between V_{OUT} terminal and V_{SS} terminal as close as possible. A ceramic capacitor with capacitance value of at least $1.0\mu F$ is recommended. Of course, the suitable capacitance value should be different by the condition of each application. In addition, an input capacitor (C_{IN}) with capacitance value of at least $1.0\mu F$ is also recommended between V_{IN} terminal and V_{SS} terminal for stable input power.

- **Output capacitor (C_L) Over current protection and short circuit protection**

Built-in over current protection circuit performs circuit protection from over current as a current limiter. When the load current reaches the limit level, the output voltage drops and output current also decreases accordingly. A current of typical 40mA will flow when output terminal is shorted.



TYPICAL CHARACTERISTICS – Output Voltage vs. Output Current

- JY1103-L120x ($V_{OUT} = 1.2V$)

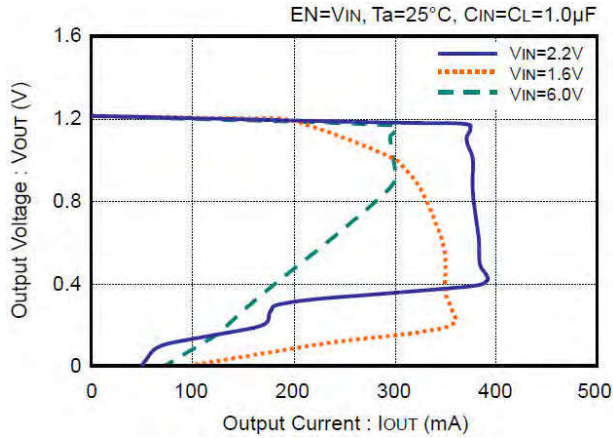

- JY1103-L120x ($V_{OUT} = 1.2V$)

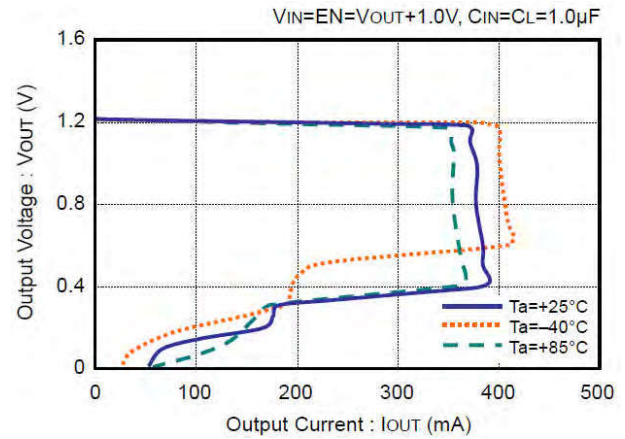

- JY1103-L180x ($V_{OUT} = 1.8V$)

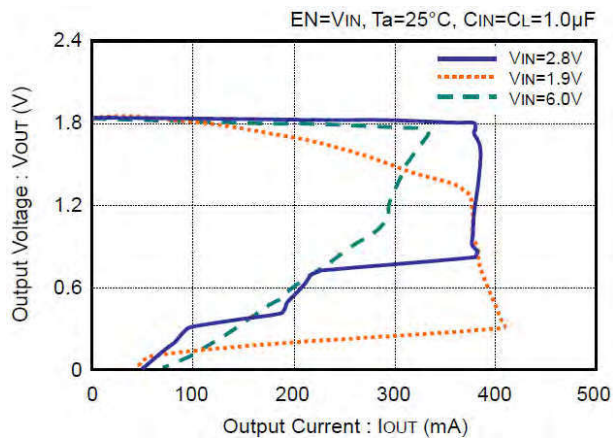

- JY1103-L180x ($V_{OUT} = 1.8V$)

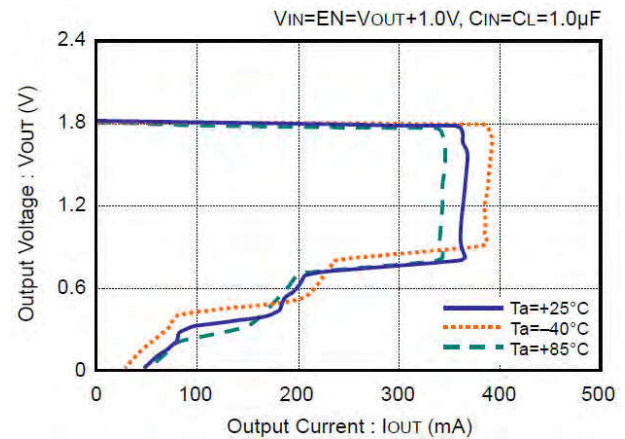

- JY1103-H330x ($V_{OUT} = 3.3V$)

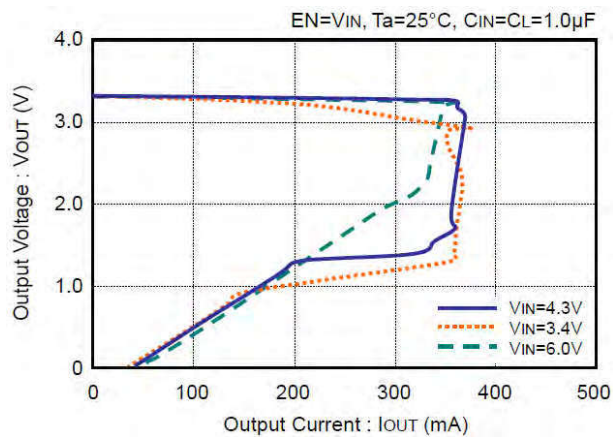

- JY1103-H330x ($V_{OUT} = 3.3V$)

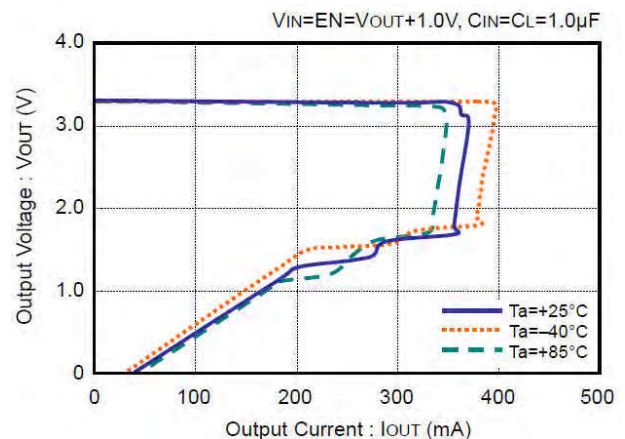



TYPICAL CHARACTERISTICS – Output Voltage vs. Input Voltage

- JY1103-L120x ($V_{OUT} = 1.2V$)

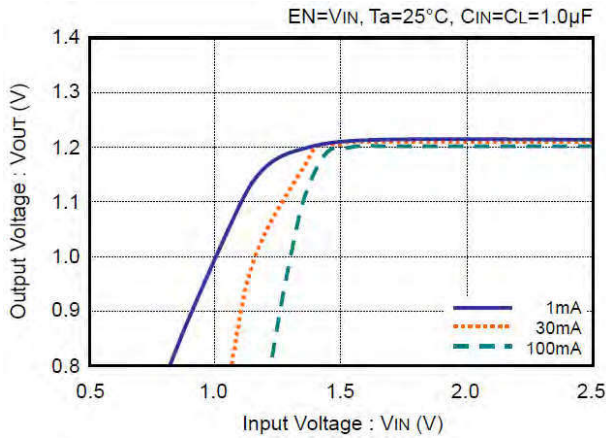

- JY1103-L120x ($V_{OUT} = 1.2V$)

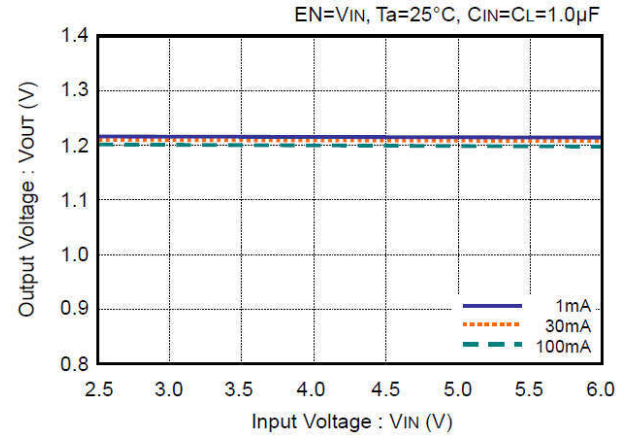

- JY1103-L180x ($V_{OUT} = 1.8V$)

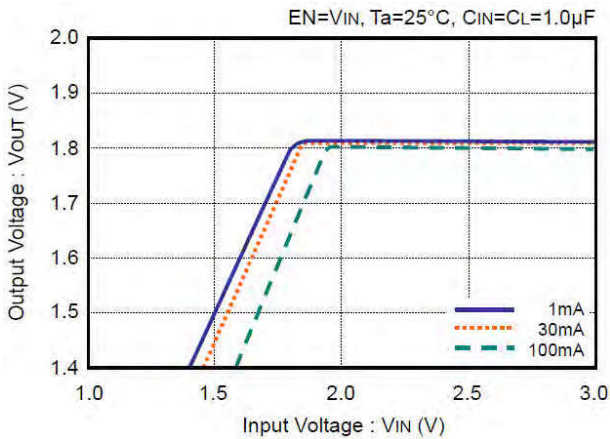

- JY1103-L180x ($V_{OUT} = 1.8V$)

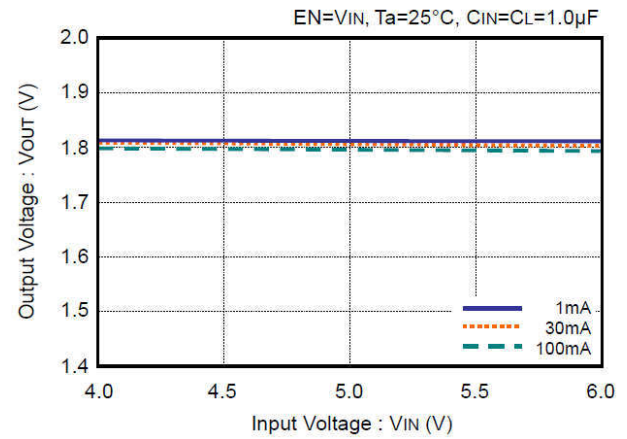

- JY1103-H330x ($V_{OUT} = 3.3V$)

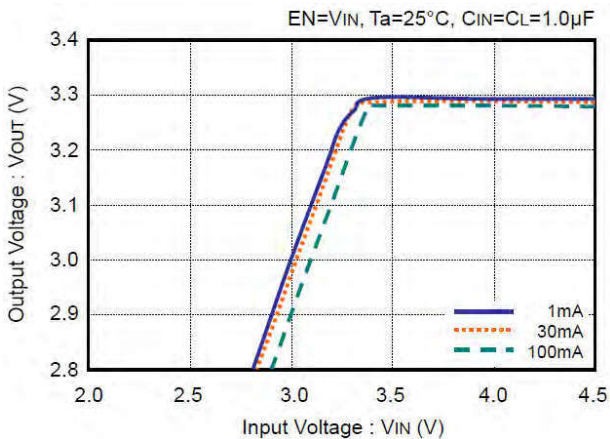

- JY1103-H330x ($V_{OUT} = 3.3V$)

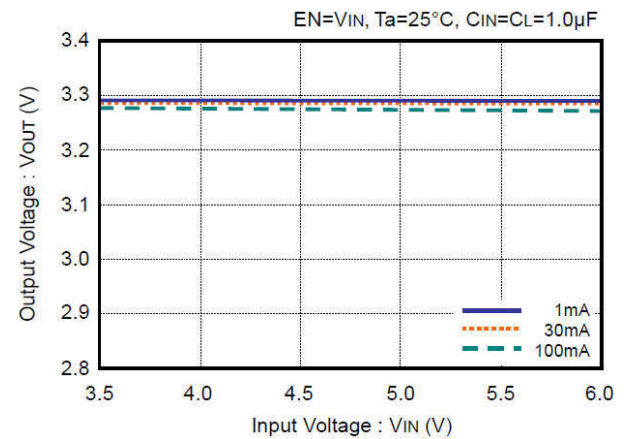



TYPICAL CHARACTERISTICS – Output Voltage vs. Ambient Temperature

- JY1103-L180x ($V_{OUT} = 1.8V$)

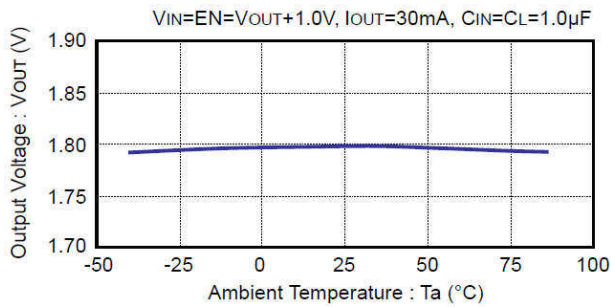

- JY1103-H330x ($V_{OUT} = 3.3V$)

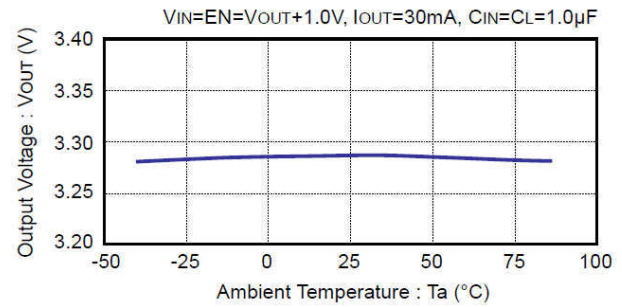

TYPICAL CHARACTERISTICS – C_L Discharge Resistance vs. Ambient Temperature

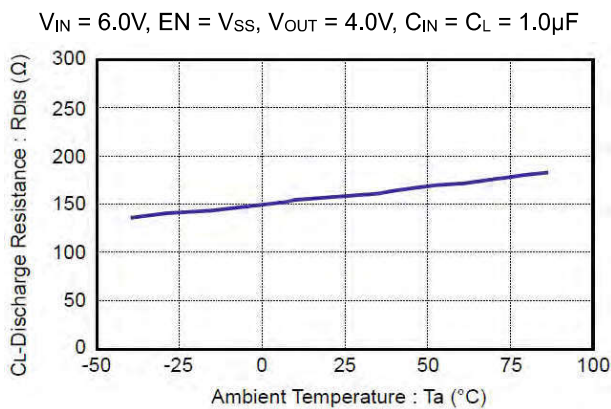

TYPICAL CHARACTERISTICS – Supply Current vs. Input Voltage

- JY1103-L180x ($V_{OUT} = 1.8V$)

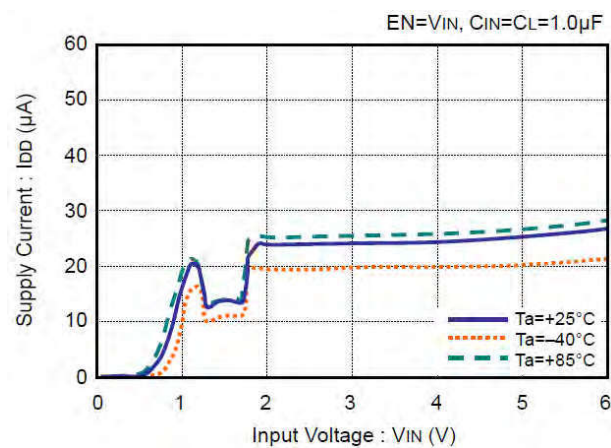

- JY1103-H330x ($V_{OUT} = 3.3V$)

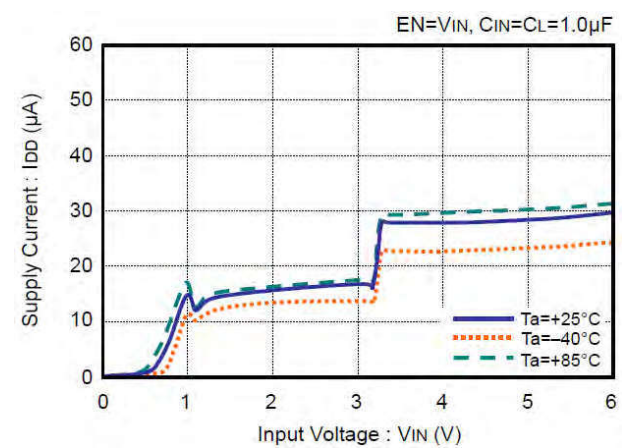



TYPICAL CHARACTERISTICS – Load Transient Response

- JY1103-L180x ($V_{OUT} = 1.8V$)

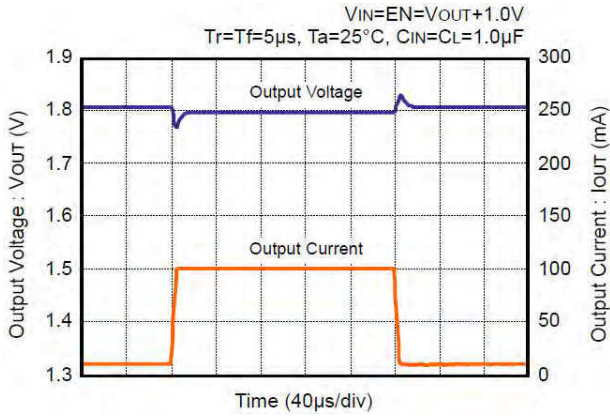

- JY1103-H330x ($V_{OUT} = 3.3V$)

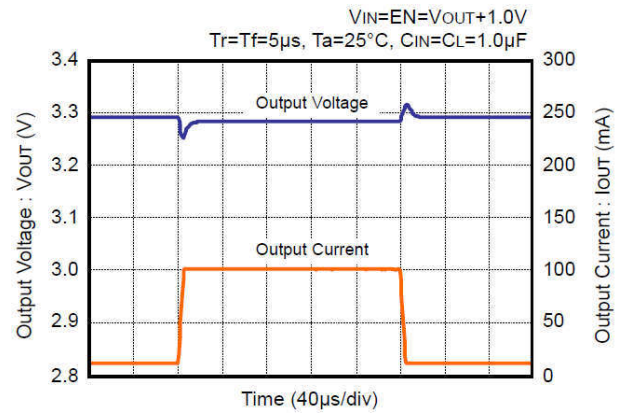

TYPICAL CHARACTERISTICS – Input Transient Response ($I_{OUT} = 100mA$)

- JY1103-L180x ($V_{OUT} = 1.8V$)

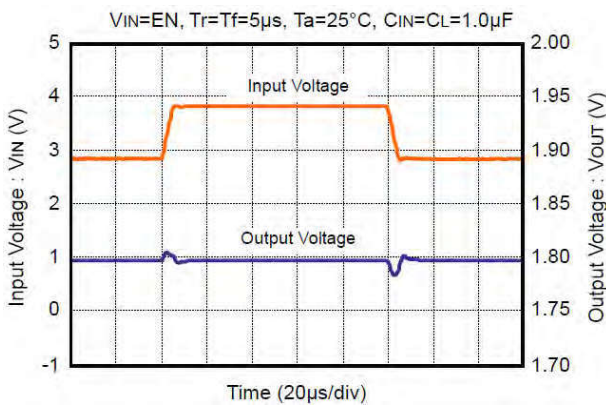

- JY1103-H330x ($V_{OUT} = 3.3V$)

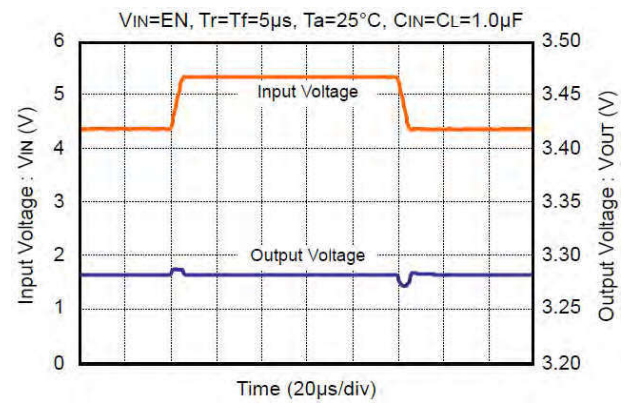

TYPICAL CHARACTERISTICS – EN Rise Time ($I_{OUT} = 100mA$)

- JY1103-L180x ($V_{OUT} = 1.8V$)

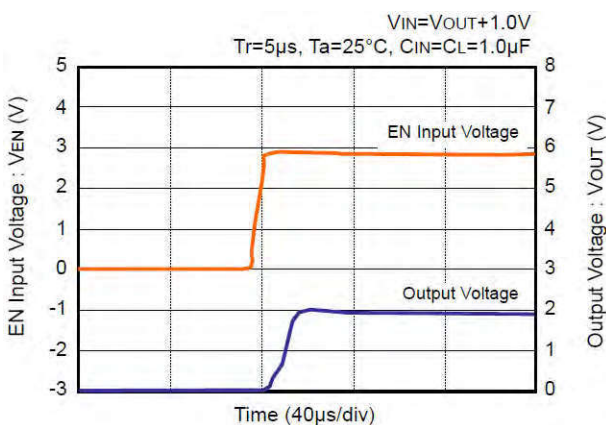

- JY1103-H330x ($V_{OUT} = 3.3V$)

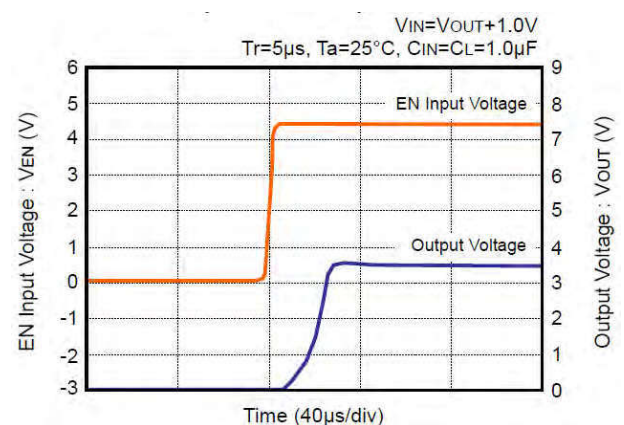



TYPICAL CHARACTERISTICS – Input Rise Time ($I_{OUT} = 100\text{mA}$)

- JY1103-L180x ($V_{OUT} = 1.8\text{V}$)

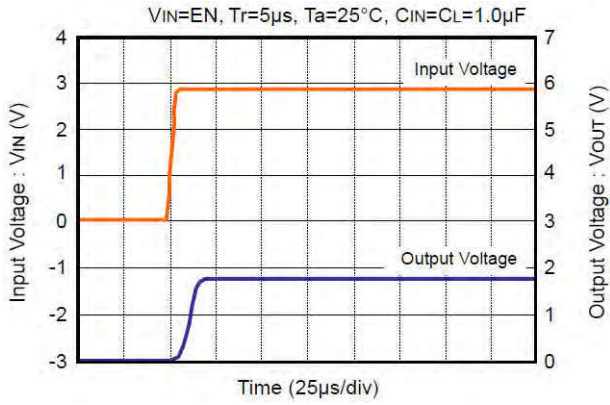

- JY1103-H330x ($V_{OUT} = 3.3\text{V}$)

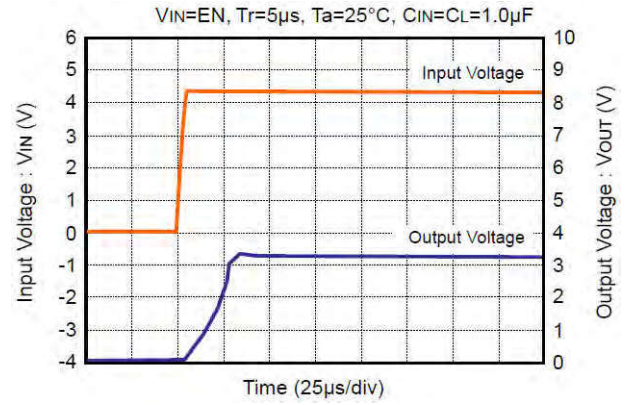



PACKAGE DIMENSIONS (SOT23)

MSL-3

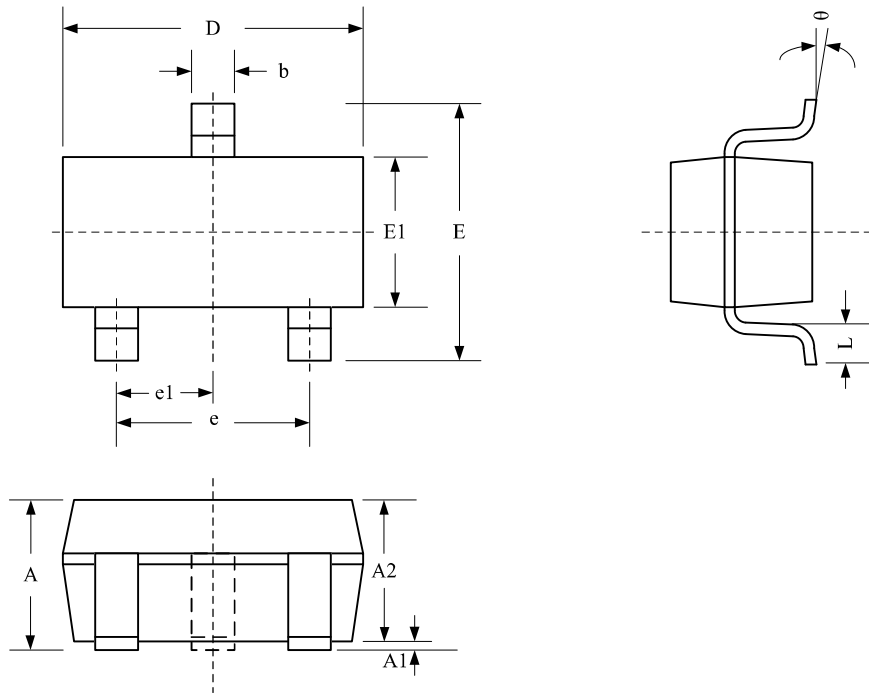

Package Dimensions (Controlling dimensions are in millimeters)

Symbol	Dimensions (mm)			Dimensions (Inches)		
	Minimum	Typical	Maximum	Minimum	Typical	Maximum
A	—	—	1.450	—	—	0.057
A1	0.000	—	0.150	0.000	—	0.006
A2	—	—	1.300	—	—	0.012
b	0.300	—	0.500	0.012	—	0.020
D	2.90 BSC			0.114 BSC		
e1	0.95 BSC			0.037 BSC		
e	1.90 BSC			0.075 BSC		
E	2.80 BSC			0.110 BSC		
E1	1.60 BSC			0.063 BSC		
L	0.300	0.450	0.600	0.012	0.018	0.024
θ	0°	4°	8°	0°	4°	8°



PACKAGE DIMENSIONS (SOT23-5L)

MSL-3

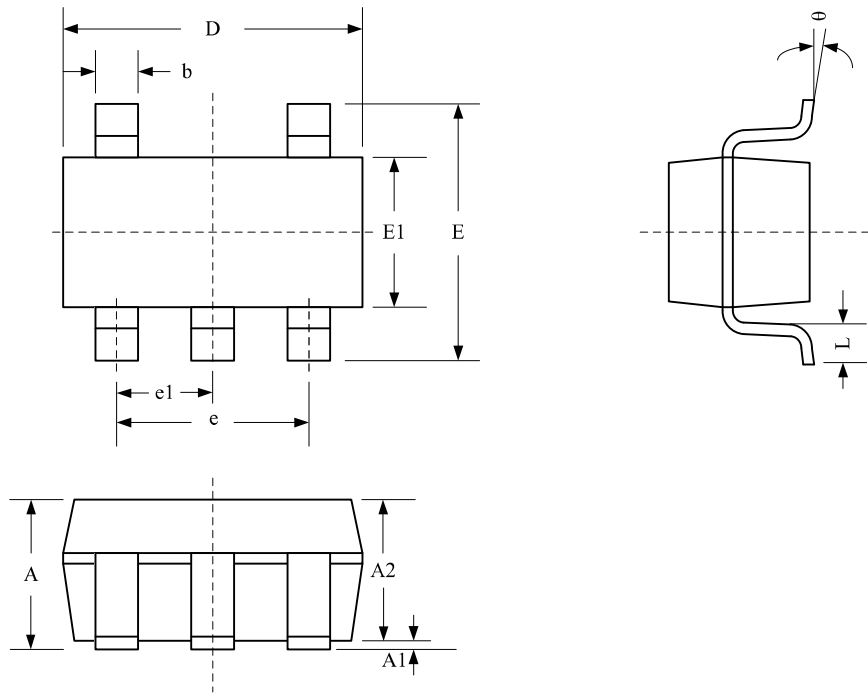

Package Dimensions (Controlling dimensions are in millimeters)

Symbol	Dimensions (mm)			Dimensions (Inches)		
	Minimum	Typical	Maximum	Minimum	Typical	Maximum
A	—	—	1.450	—	—	0.057
A1	0.000	—	0.150	0.000	—	0.006
A2	—	—	1.300	—	—	0.012
b	0.300	—	0.500	0.012	—	0.020
D	2.90 BSC			0.114 BSC		
e1	0.95 BSC			0.037 BSC		
e	1.90 BSC			0.075 BSC		
E	2.80 BSC			0.110 BSC		
E1	1.60 BSC			0.063 BSC		
L	0.300	0.450	0.600	0.012	0.018	0.024
θ	0°	4°	8°	0°	4°	8°



PACKAGE DIMENSIONS (SOT23-6L)

MSL-3

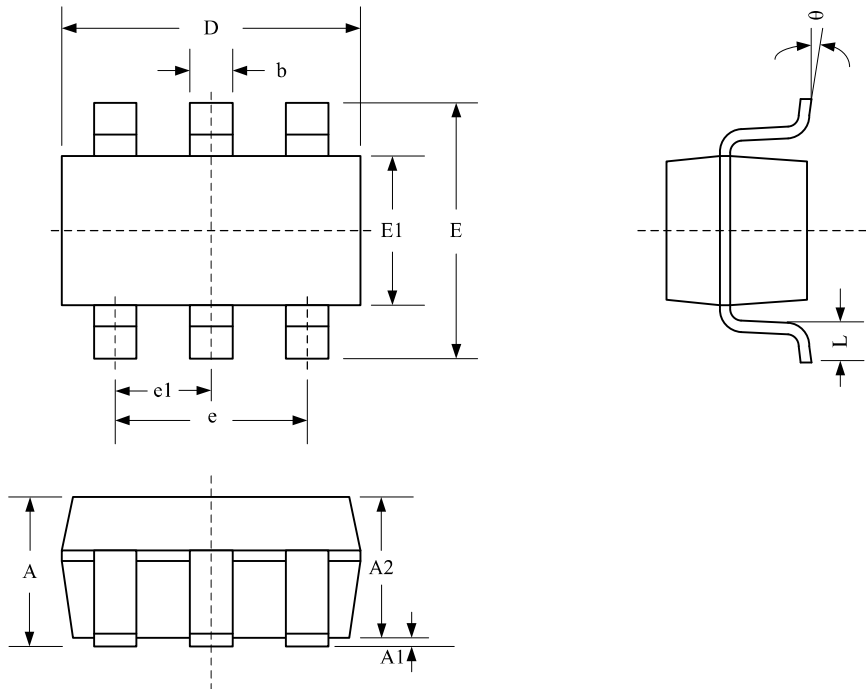

Package Dimensions (Controlling dimensions are in millimeters)

Symbol	Dimensions (mm)			Dimensions (Inches)		
	Minimum	Typical	Maximum	Minimum	Typical	Maximum
A	—	—	1.450	—	—	0.057
A1	0.000	—	0.150	0.000	—	0.006
A2	—	—	1.300	—	—	0.012
b	0.300	—	0.500	0.012	—	0.020
D	2.90 BSC			0.114 BSC		
e1	0.95 BSC			0.037 BSC		
e	1.90 BSC			0.075 BSC		
E	2.80 BSC			0.110 BSC		
E1	1.60 BSC			0.063 BSC		
L	0.300	0.450	0.600	0.012	0.018	0.024
θ	0°	4°	8°	0°	4°	8°



PACKAGE DIMENSIONS (SOT89-3L)

MSL-3

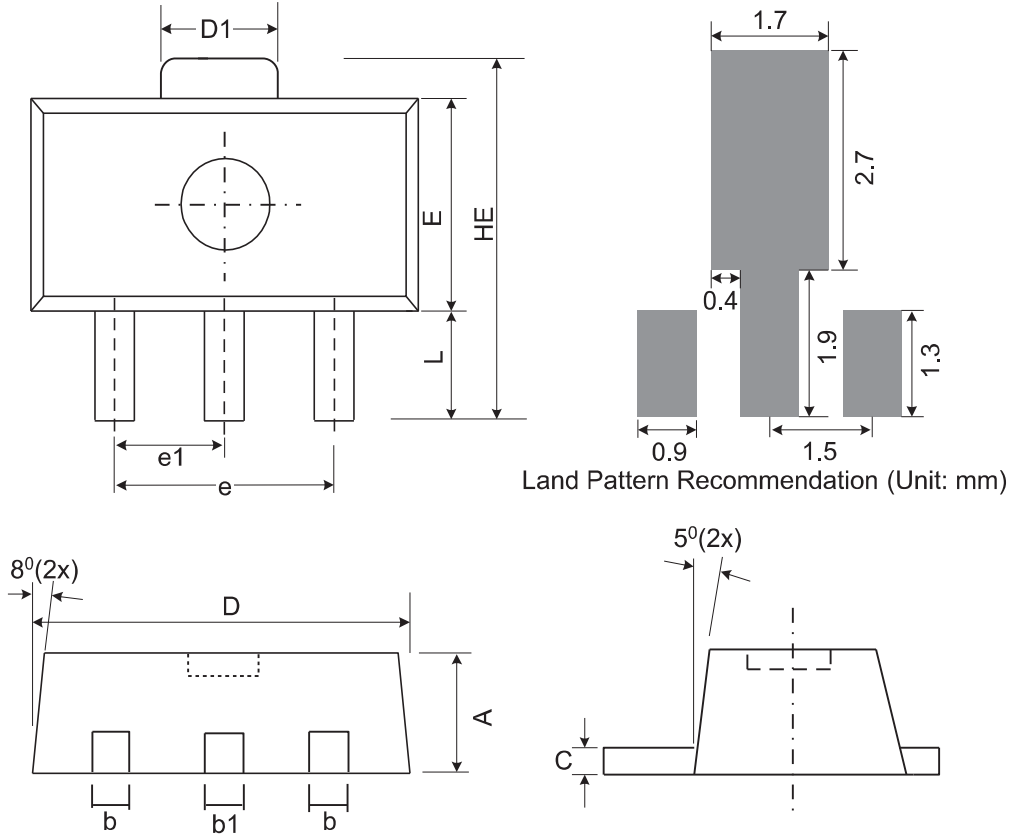

Symbol	Dimensions in Millimeters			Dimensions in Inches		
	Min.	Nom.	Max.	Min.	Nom.	Max.
A	1.40	1.50	1.60	0.055	0.059	0.063
b	0.36	0.42	0.48	0.014	0.017	0.019
b1	0.44	0.50	0.56	0.017	0.02	0.022
C	0.35	0.40	0.44	0.014	0.016	0.017
D	4.40	4.50	4.60	0.173	0.177	0.181
D1	1.35	1.59	1.83	0.053	0.063	0.072
e	3.0 BSC			0.118 BSC		
e1	1.5 BSC			0.059 BSC		
E	2.29	2.45	2.60	0.09	0.097	0.102
HE	3.94	4.10	4.25	0.155	0.161	0.167
L	0.80	1.00	1.20	0.031	0.04	0.047



TITAN MICRO

JY1103 Series

A high-speed low-dropout $\pm 2\%$ accuracy voltage regulator

PACKAGE DIMENSIONS

DFN 1X1-4L

MSL-1



Carrier Dimensions

SOT23-3L

PKG TYPE	W	P	E	F	D	D1	Po
SOT-23	8.00	4.00	1.75	3.50	1.50	1.00	4.00
Tolerance	+0.3/-0.1	± 0.1	± 0.1	± 0.1	± 0.1	± 0.1	± 0.1

Po10	P2	A0	B0	K0	T
40.00	2.00	3.15	2.77	1.22	0.20
± 0.2	± 0.05	± 0.1	± 0.1	± 0.1	± 0.02

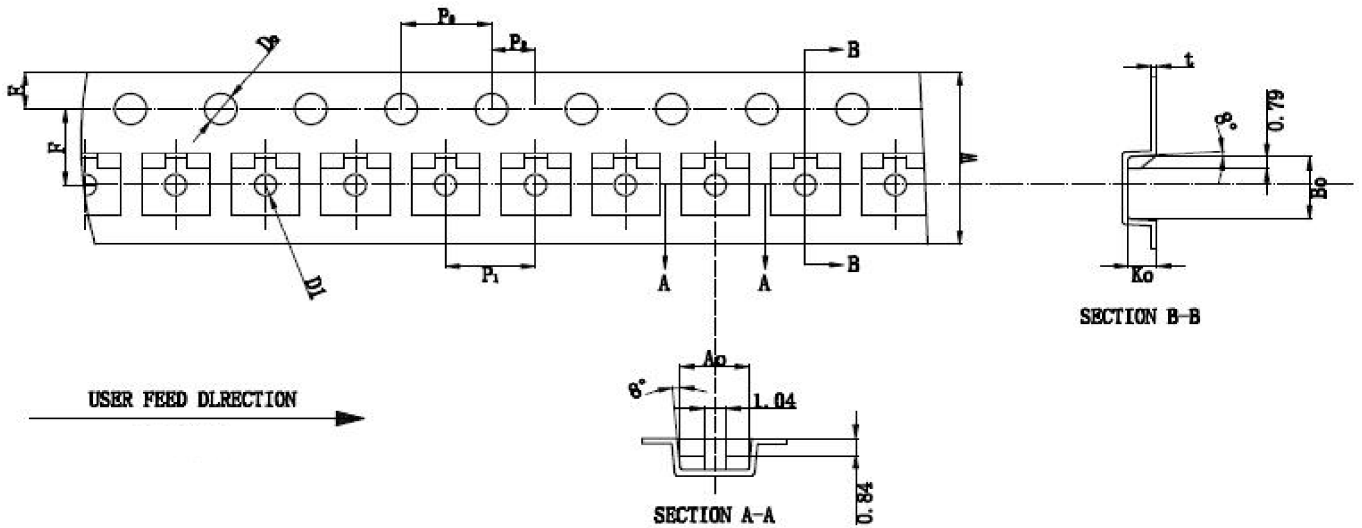



Carrier Dimensions

SOT23-5/6L

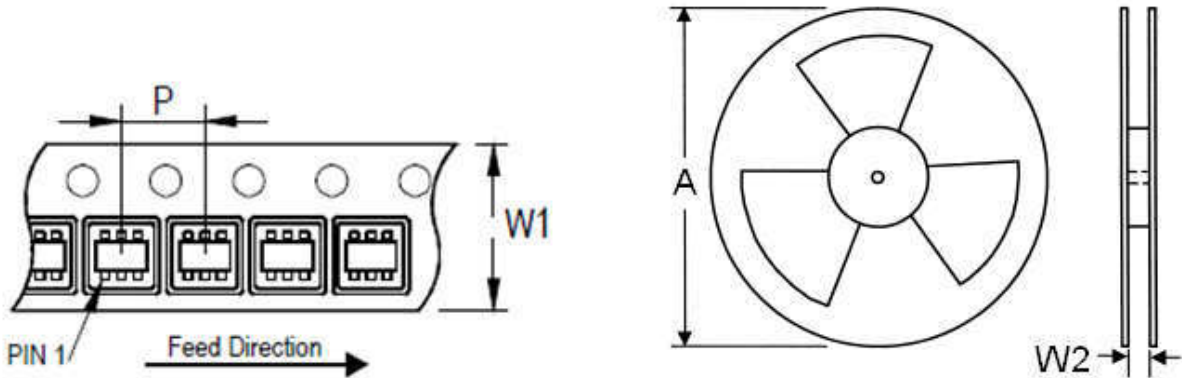

Tape Size (W1) mm	Pocket Pitch (P) mm	Reel Size (A)		Reel Width (W2) mm	Empty Cavity Length mm	Units per Reel
		in	mm			
8	4	7	180	8.4	300~1000	3,000



Carrier Dimensions

SOT89-3L

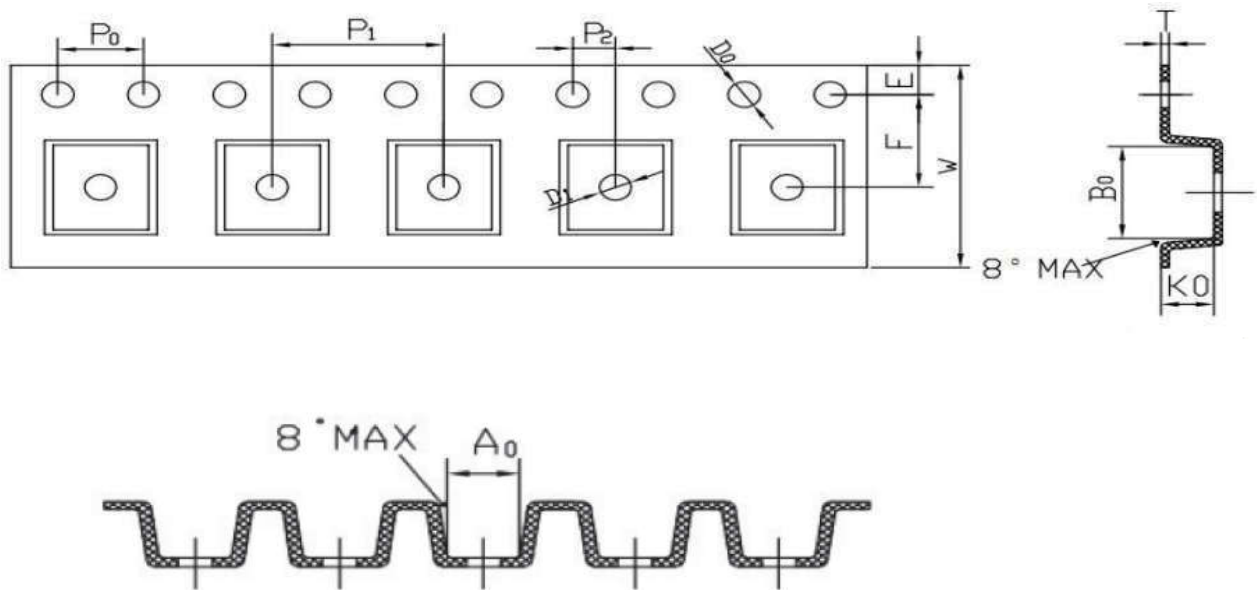

Symbol	Spec	Symbol	Spec
W	12.00 ± 0.10	A₀	4.90 ± 0.10
E	1.75 ± 0.10	B₀	4.50 ± 0.10
F	5.50 ± 0.05	K₀	1.85 ± 0.10
D₀	$1.50 (+0.10, -0)$		
D₁	$1.50 (+0.10, -0)$		
P₀	4.00 ± 0.10		
P₁	8.00 ± 0.10		
P₂	2.00 ± 0.05		
t	$0.25-0.28$		
t₁	0.05		

X-ON Electronics

Largest Supplier of Electrical and Electronic Components

Click to view similar products for [Linear Voltage Regulators](#) category:

Click to view products by [Shenzhen JingYang](#) manufacturer:

Other Similar products are found below :

[LV5684PVD-XH](#) [MCDTSA6-2R](#) [L7815ACV-DG](#) [714954EB](#) [ZMR500QFTA](#) [BA033LBSG2-TR](#) [LV5680P-E](#) [L79M05T-E](#) [L78LR05D-MA-E](#) [NCV317MBTG](#) [NTE7227](#) [MP2018GZD-33-P](#) [MP2018GZD-5-P](#) [LV5680NPVC-XH](#) [LT1054CN8](#) [ZTS6538SE](#) [UA78L09CLP](#) [UA78L09CLPR](#) [CAT6221-PPTD-GT3](#) [MC78M09CDTRK](#) [NCV51190MNTAG](#) [78M05](#) [HT7150-1](#) [UM1540DB-18](#) [XC6234H281VR-G](#) [WL2834CA-6/TR](#) [TPL730F33-5TR](#) [TLS850F1TA](#) [V50](#) [TPS549B22RVFR](#) [UM1540DB-33](#) [WL9200P3-50B](#) [WL9100P3-33B](#) [WL9005D4-33](#) [XC6219B152MR](#) [WL2855K33-3/TR](#) [PJ54BM33SE](#) [PJ9500M25SA](#) [MD7218E33PC1](#) [H7533-2PR](#) [SK7812AU](#) [SD1A30](#) [78L33](#) [TP78L33T3](#) [L78L33ACUTR](#) [SK6513ST3A-50](#) [SK6054D4-09](#) [SK6054D4-18](#) [SK6054D4-11](#) [SK6054D4-10](#) [LM79L12F](#)