



### **General Description**

The JY1106 is a low dropout linear regulator (LDO) family with 600mA output current. The output voltage can be fixed or adjustable, and are stable with 1.0uF or higher value ceramic capacitors.

The JY1106 family provides several protections, such as over current protection (OCP), short circuit protection (SCP) and over temperature protection (OTP) to protect themselves from fault application conditions.

This family of LDOs have many different packages and pin assignments. The users can refer the ordering information of this datasheet to choice the most suitable LDOs for their applications.

### **Features**

- Operating Input Voltage : 2.2V~5.5V
- Has Fixed Output Voltage (Fixed- $V_{OUT}$ ) And Adjustable Output Voltage (Adj- $V_{OUT}$ ) Options
- Output current is up to 600 mA
- Built-in Over Current Protection (OCP), Short Circuit Protection (SCP), and Over Temperature Protection (OTP)
- Package : SOT223-3L, SOT23-5L, SOP-8L and WDFN2020-6L Packages

### **Applications**

- Portable Electronics
- Wireless Applications
- Battery Power Devices



#### Block Diagram

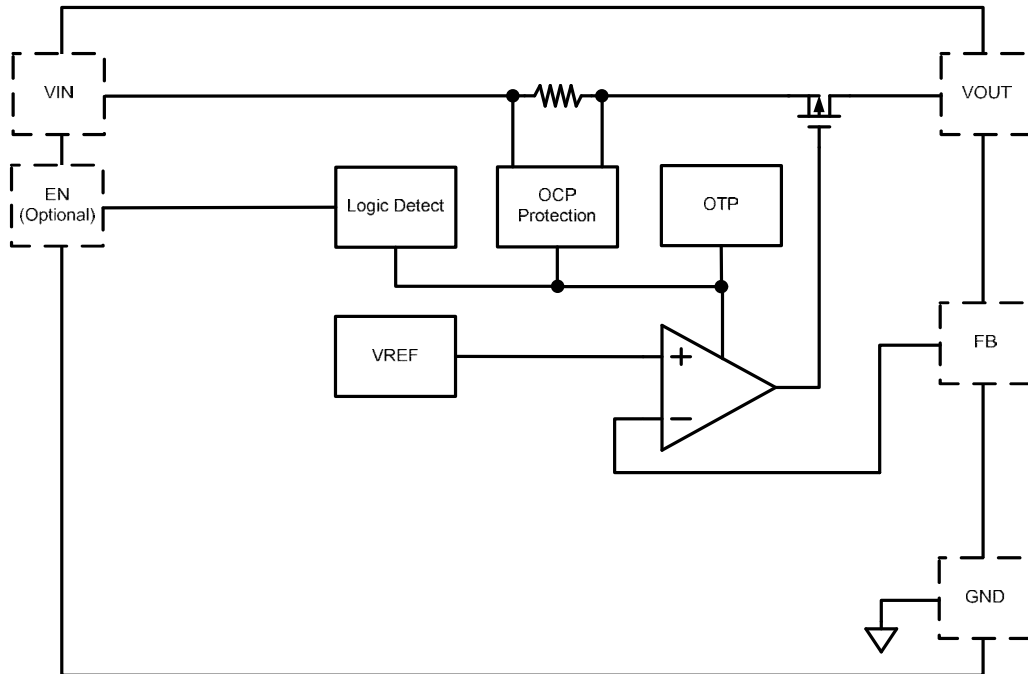

**Adjustable Output**

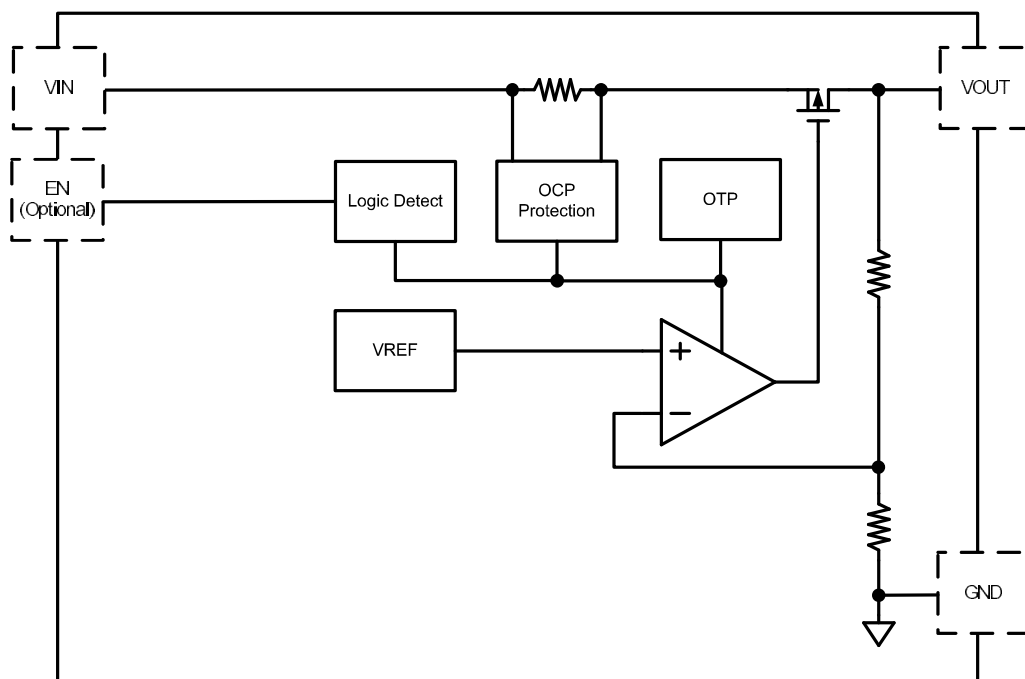

**Fixed Output**



### Pin Assignment (Contd.)

**SOT23-5L**  
Top View

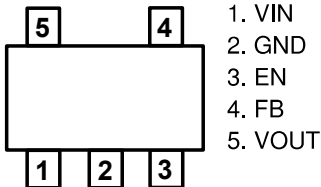

**WDFN2020-6L**

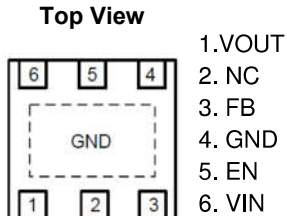

**SOP-8L**  
Top View

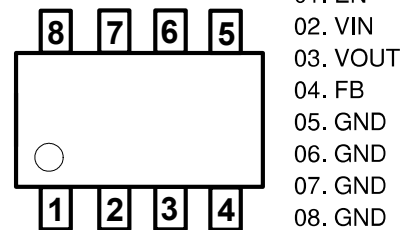

**SOT223-3L**  
Top View

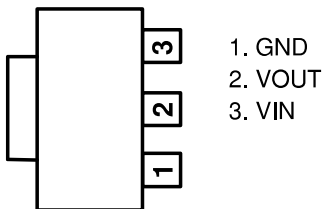

### Pin Descriptions

Pin Name	Pin Description
V <sub>IN</sub>	Voltage input. The input capacitor in the range of 1uF to 10uF is sufficient.
GND	Ground
V <sub>OUT</sub>	LDO Output
FB (Optional)	Feedback Input for Setting the Output Voltage. Connect to an external resistor divider for adjustable output operation.
EN (Optional)	<b>Enable pin (Active High)</b> A pull-high resistor is inside the IC. Need an external Logic-low source to disable the LDO.
NC	No connection



### Ordering Information

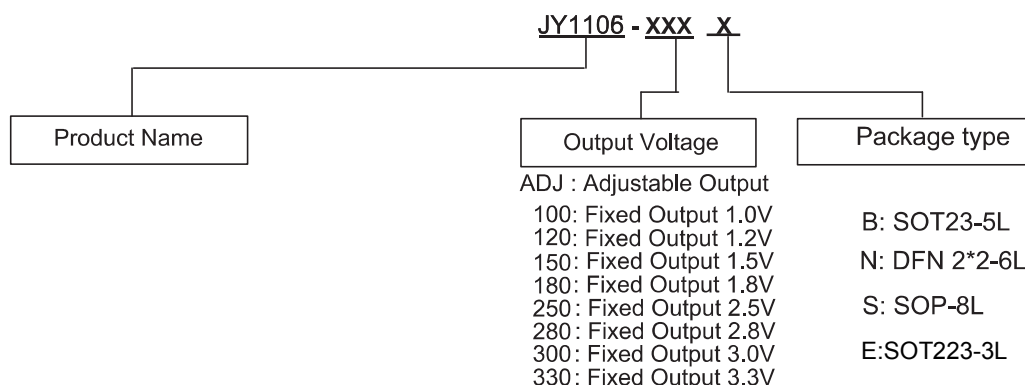

Part name	Packing	Quantity Per Reel
JY1106	SOT23-5	3000
	WDFN 2*2	3000
	SOP-8L	3000
	SOT223-3L	3000

### Marking Information

ADJ

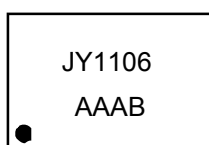

JY1106: Product Name

AAA: Wafer's Lot No

B: Internal Code

(1)

Fixed

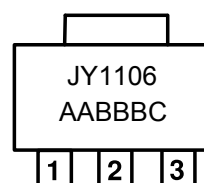

JY1106: Product Name

AA: Output voltage

eg: 12 - 1.2V

18 - 1.8V

33 - 3.3V

BBB: Wafer's Lot No

C: Internal Code

(2)



### Absolute Maximum Ratings

Operate over the “Absolute Maximum Ratings” may cause permanent damage to the device. Exposure to such conditions for extended time may still affect the reliability of the device.

Parameter	Symbol	Value	Unit
V <sub>IN</sub> Pin Voltage	V <sub>IN</sub>	GND - 0.3 to GND + 6	V
FB, EN and V <sub>OUT</sub> pin Voltages	V <sub>FB</sub> , V <sub>EN</sub> & V <sub>OUT</sub>	GND - 0.3 to V <sub>IN</sub> + 0.3	V
Maximum I <sub>OUT</sub> Current (Note 1)	I <sub>OUT</sub>	Internal Limit	mA
Junction Temperature Range	T <sub>J</sub>	-40 to +125	°C
Storage Temperature Range	T <sub>STR</sub>	-40 to +150	°C
Lead Temperature (Soldering, 10 Seconds)	T <sub>Lead</sub>	260	°C
ESD Withstand Voltage: -Human Body Model (HBM), Model = 2 -Machine Model (MM) Model = B	V <sub>ESD</sub>	2000 200	V V
Thermal Resistance (Junction to Ambient)	SOT23-5L	θ <sub>JA</sub>	°C/W
	SOP-8L		
	SOT223-3L		
	WDFN2020-6L		
Power Dissipation	SOT23-5L	P <sub>D</sub>	mW
	SOP-8L		
	SOT223-3L		
	WDFN2020-6L		
Moisture Sensitivity	MSL	Please refer the MSL label on the IC package bag/carton for detail	

Note 1 : The I<sub>OUT</sub> of the LDO will be limited by the thermal protection , if the PCB design can't dissipate the heat generated by the LDO

Note 2 : R<sub>θJA</sub> is highly dependent on the PCB heat sink area.



#### **Recommended Operating Conditions**

Characteristics	Symbol	Min	Max	Unit
Supply Input Voltage	$V_{IN}$	2.2	5.5	V
Junction Temperature Range	$T_J$	-40	125	°C
Ambient Temperature Range	$T_A$	-40	85	°C

Note 3 : If the IC experienced OTP, then the temperature may need to drop to < OTP recover temperature to let the IC recover.



## Electrical Characteristics

( $V_{IN} = V_{OUT} + 1V$  or  $V_{IN} = 2.5V$  whichever is greater,  $C_{IN} = C_{OUT} = 1\mu F$ ,  $T_A = 25^\circ C$ , unless otherwise noted)

Parameter	Symbol	Test Conditions	Min	Typ	Max	Units	
<b>Input Voltage (All Versions)</b>							
Input Voltage Range (Note 4)	$V_{IN}$		2.2	-	5.5	V	
<b>Feedback Voltage ( ADJ-<math>V_{OUT}</math> Versions)</b>							
FB Voltage	$V_{FB}$	$V_{IN} = V_{IN(min)}$ to 5.5V, $I_{OUT} = 1mA$ ( $T_A = 25^\circ C$ )	0.788	0.8	0.812	V	
FB Input Leakage Current	$I_{FB}$	$V_{FB} = 1.0V$ , $V_{IN} = V_{IN(min)}$ to 5.5V,	-100	-	100	nA	
Adjustable Output Voltage Range	$V_{OUT}$		$V_{FB}$	-	4.5	V	
<b><math>V_{OUT}</math> Voltage (Fixed-<math>V_{OUT}</math> Versions)</b>							
Output Voltage Accuracy	$\Delta V_{OUT}$	$V_{IN} = V_{IN(min)}$ to 5.5V, $I_{OUT} = 1mA$ ( $T_A = 25^\circ C$ )	-1.5	-	+1.5	%	
Quiescent Current	$I_Q$	$V_{IN} = 2.5V$ , When $V_{OUT} \leq 2V$	-	50	70	$\mu A$	
		$V_{IN} = V_{OUT} + 1V$ , When $V_{OUT} \geq 2V$	-	70	100		
Shutdown Current	$I_{SD}$	$V_{IN} = 5.5V$ , $V_{EN} = 0V$	-	-	1	$\mu A$	
Dropout Voltage (Note4)	$V_{DROP}$	$I_{OUT} = 600mA$	$1.0V \leq V_{OUT} \leq 2.0V$	-	-	1200	mV
			$2.0V < V_{OUT} \leq 2.5V$	-	-	600	
			$2.5V < V_{OUT} < 4.5V$	-	-	550	
Current Limit (Note 5)	$I_{LIMIT}$	$V_{OUT} = V_{OUT(NON)} \times 90\%$	600	800		mA	
Short Circuit Current	$I_{short}$	$V_{OUT} < 0.4V$		100	200	mA	
Line Regulation $\frac{\Delta V_{OUT}}{\Delta V_{IN}} \times 100\%$ $\frac{\Delta V_{OUT}}{V_{OUT}}$	$\Delta V_{LINE}$	$I_{OUT} = 1mA$ , $V_{IN} = V_{OUT} + 1V$ to 5.5V	-	0.1	0.2	%/V	
Load Regulation (Note 6) $\frac{\Delta V_{OUT}}{V_{OUT}} \times 100\%$	$\Delta V_{LOAD}$	$I_{OUT} = 1m \sim 600mA$ , $V_{IN} = V_{OUT} + 1V$ or $V_{IN} = 2.5V$ whichever is greater	-	1	1.5	%	



### Electrical Characteristics (Contd.)

( $V_{IN} = V_{OUT} + 1V$  or  $V_{IN} = 2.5V$  whichever is greater,  $C_{IN} = C_{OUT} = 1\mu F$ ,  $T_A = 25^\circ C$ , unless otherwise noted)

Parameter	Symbol	Test Conditions	Min	Typ	Max	Units
<b>LDO Basic Characteristics ( All Versions)</b>						
$V_{OUT}$ Temperature Coefficient (Note 7)	$T_C$	$I_{OUT} = 10mA$	-	30	-	ppm/°C
Ripple Rejection (Note 7)	PSRR	$I_{OUT} = 10mA, f = 1KHz$	-	60	-	db
Thermal Shutdown (Note 7)	$T_S$		-	155	-	°C
Thermal Shutdown Hysteresis (Note 7)	$T_{SH}$		-	30	-	°C
<b>Enable (EN, Optional)</b>						
Enable Input Threshold	$V_{ENH}$		1.4	-	$V_{IN}$	V
	$V_{ENL}$		0	-	0.4	
Enable Pin Current	$I_{ENH}$	$V_{EN} = V_{IN}$	-	-	0.1	uA

Note 4: Minimum  $V_{IN}$  voltage is defined by output adds a dropout voltage,  $V_{IN(min)} = V_{OUT} + V_{DROPOUT}$ .

Note 5. Current limit and short circuit current are measured at constant junction temperature by using pulsed testing with a low ON time.

Note 6. Load Regulation is measured at constant junction temperature by using pulsed testing with a low ON time.

Note 7. Guarantee by design. Not test when manufacture.

### Application Circuit

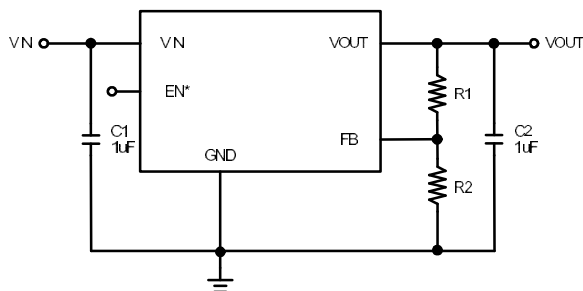

Adjustable Output

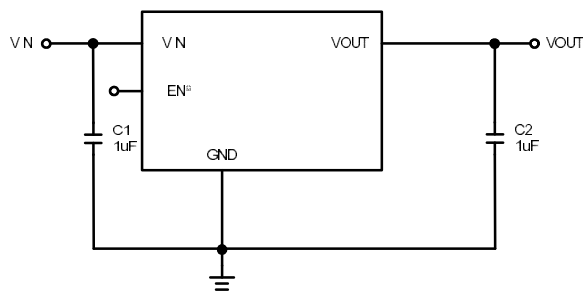

Fixed Output





#### PACKAGE DIMENSIONS

##### (1) SOT23-5L

MSL-3

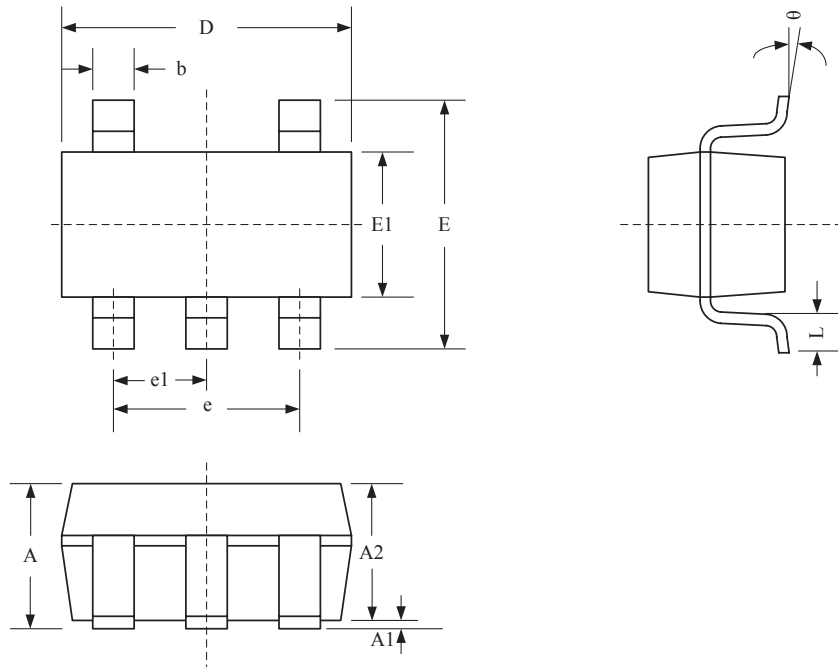

Package Dimensions (Controlling dimensions are in millimeters)

Symbol	Dimensions (mm)			Dimensions (Inches)		
	Minimum	Typical	Maximum	Minimum	Typical	Maximum
A	—	—	1.450	—	—	0.057
A1	0.000	—	0.150	0.000	—	0.006
A2	—	—	1.300	—	—	0.012
b	0.300	—	0.500	0.012	—	0.020
D	2.90 BSC			0.114 BSC		
e1	0.95 BSC			0.037 BSC		
e	1.90 BSC			0.075 BSC		
E	2.80 BSC			0.110 BSC		
E1	1.60 BSC			0.063 BSC		
L	0.300	0.450	0.600	0.012	0.018	0.024
$\theta$	0	4	8	0	4	8



#### PACKAGE DIMENSIONS

(2) SOP-8L  
MSL-3

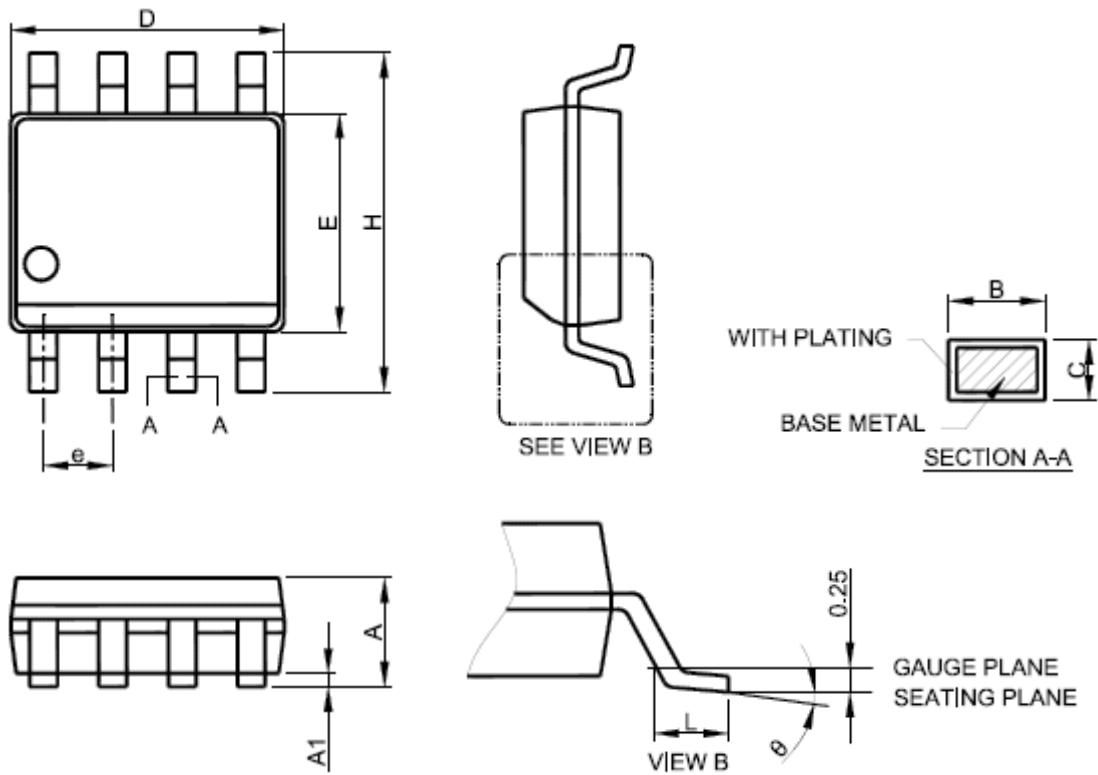

Symbol	Dimensions In Millimeters	
	Min	Max
A	1.35	1.75
A1	0.10	0.25
B	0.33	0.51
C	0.19	0.25
D	4.70	5.10
E	3.70	4.10
E	1.27BSC	
H	5.80	6.20
L	0.40	1.27
$\theta$	0	8°



#### PACKAGE DIMENSIONS

#### (3) WDFN2020-6L

MSL-1

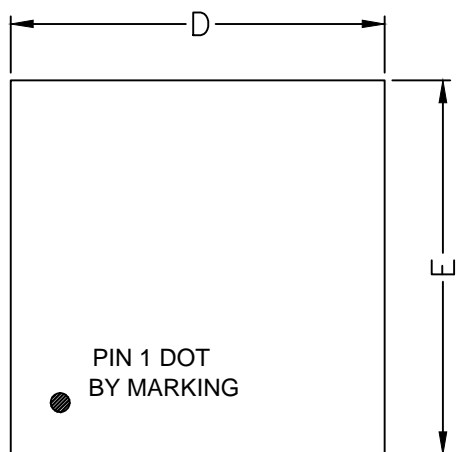

TOP VIEW

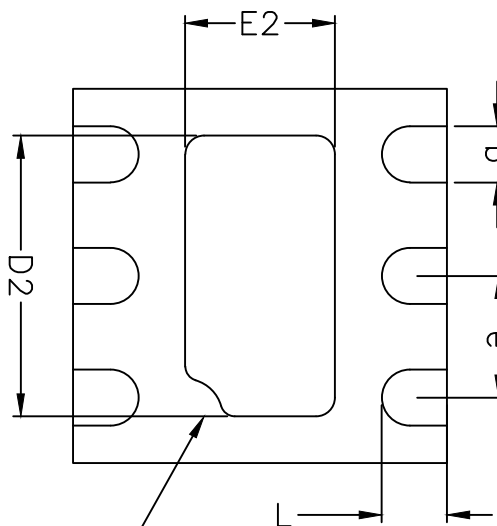

PIN 1 IDENTIFICATION  
CHAMFER C 0.3mm  
BOTTOM VIEW

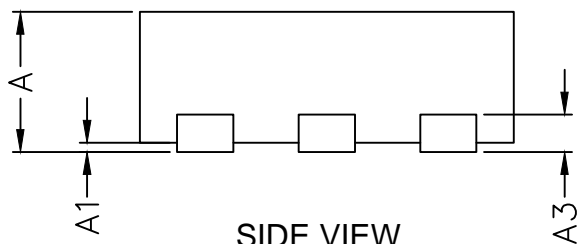

SIDE VIEW

PKG	COMMON DIMENSIONS(MM)		
	X1:EXTREME THIN		
REF	MIN	NOM	MAX
A	0.7	0.75	0.8
A1		—	0.05
A3	0.2REF		
D	1.95	2.00	2.05
E	1.95	2.00	2.05
b	0.25	0.3	0.35
L	0.25	0.35	0.45
D2	1.35	1.5	1.6
E2	0.65	0.8	0.9
e	0.65 BSC		



#### PACKAGE DIMENSIONS

#### (4) SOT223-3L

MSL-3

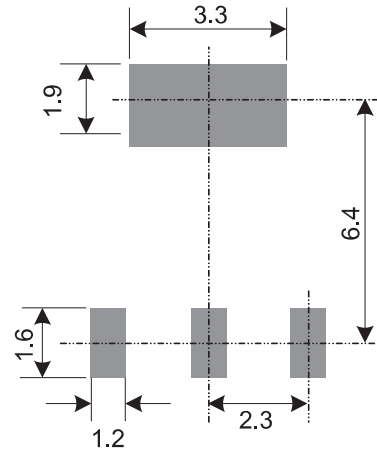
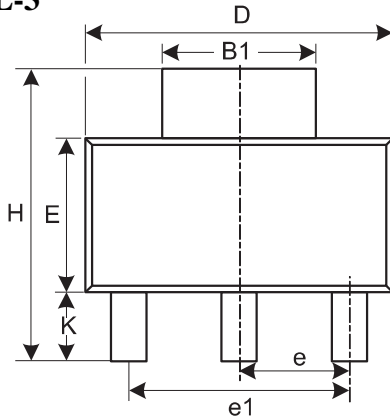

Land Pattern Recommendation (Unit: mm)

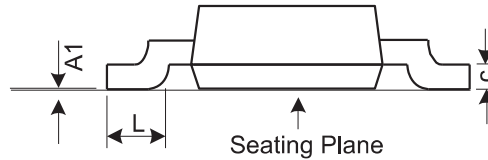
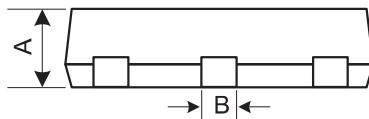

Symbol	Dimensions in Millimeters			Dimensions in Inches		
	Min.	Nom.	Max.	Min.	Nom.	Max.
A	-	-	1.8	-	-	0.071
A1	0.02	0.06	0.1	0.001	0.002	0.004
B	0.66	0.75	0.84	0.026	0.03	0.033
B1	2.9	3	3.1	0.114	0.118	0.122
C	0.23	0.315	0.35	0.009	0.012	0.014
D	6.3	6.5	6.7	0.248	0.256	0.264
E	3.3	3.5	3.7	0.13	0.138	0.146
H	6.7	7	7.3	0.264	0.278	0.287
L	0.75	-	-	0.03	-	-
K	1.5	1.75	2	0.059	0.069	0.079
e	2.3 Basic			0.091 Basic		
e1	4.6 Basic			0.181 Basic		



### Carrier Dimensions

### SOT23-5

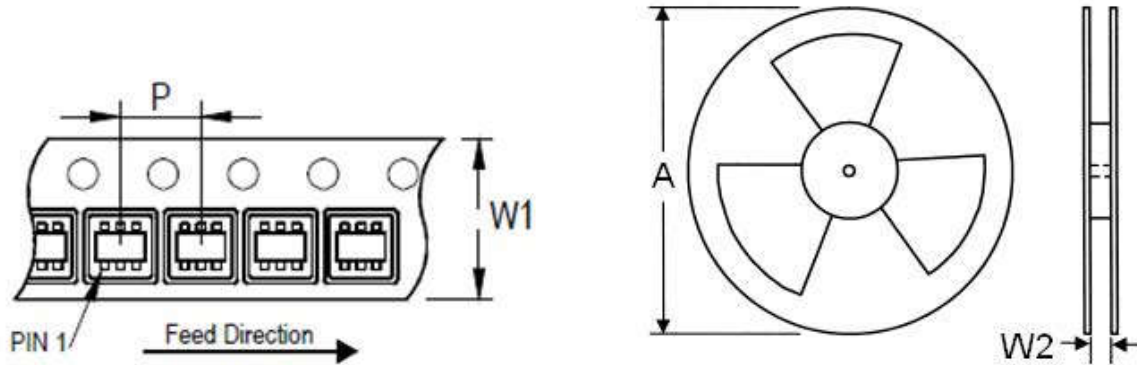

Tape Size (W1) mm	Pocket Pitch (P) mm	Reel Size (A)		Reel Width (W2) mm	Empty Cavity Length mm	Units per Reel
		in	mm			
8	4	7	180	8.4	300~1000	3,000



Carrier Dimensions

SOP-8L

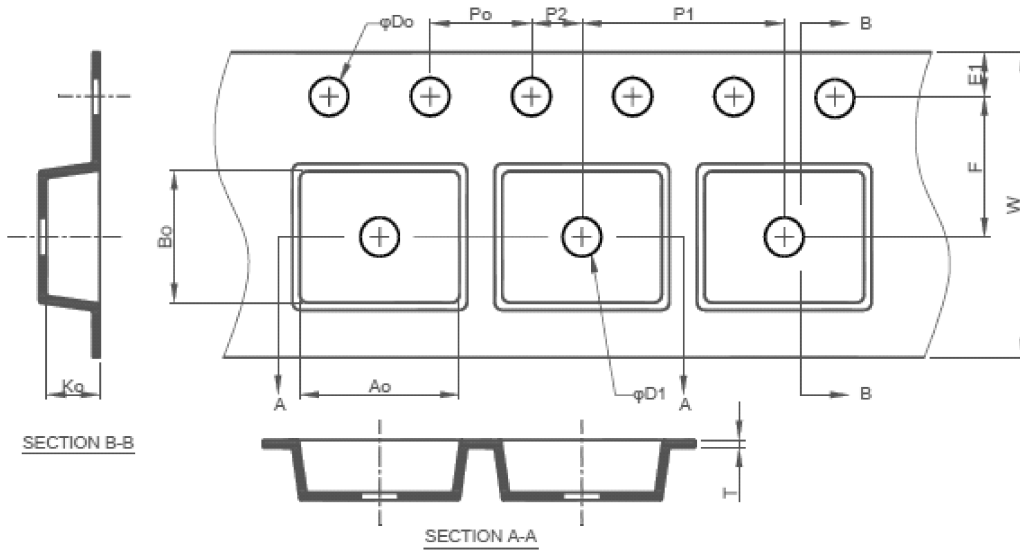

- Note: 1. Refer to EIA-481-B  
 2. 10 sprocket hole pitch cumulative tolerance  $\pm 0.2$   
 3. Material: conductive polystyrene  
 4. A0 and B0 measured on a plane 0.3mm above the bottom of the pocket  
 5. K0 measured from a plane on the inside bottom of the pocket to the top surface of the carrier

SYMBOL	A0	B0	K0	T	D0	D1
SPEC	6.400±0.100	5.350±0.100	2.000±0.100	0.250±0.020	1.550±0.050	1.550±0.100
SYMBOL	P0	P1	P2	E1	F	W
SPEC	4.000±0.100	8.000±0.100	2.000±0.050	1.750±0.100	5.500±0.050	12.000±0.30

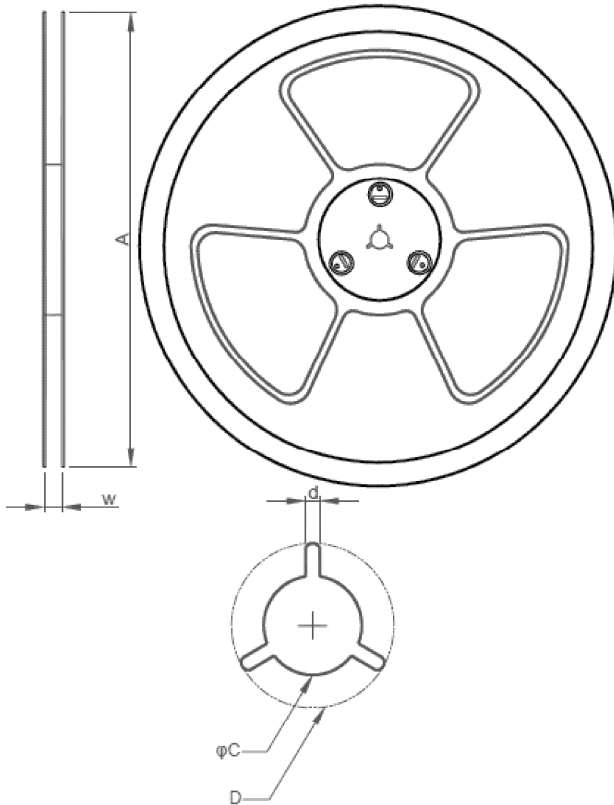

SOP-8	330±2	12.4	+2.0 -0.0	13.0	+0.5 -0.2	1.5 MIN.	20.2 MIN.
-------	-------	------	--------------	------	--------------	----------	-----------



### Carrier Dimensions

### SOT223-3L

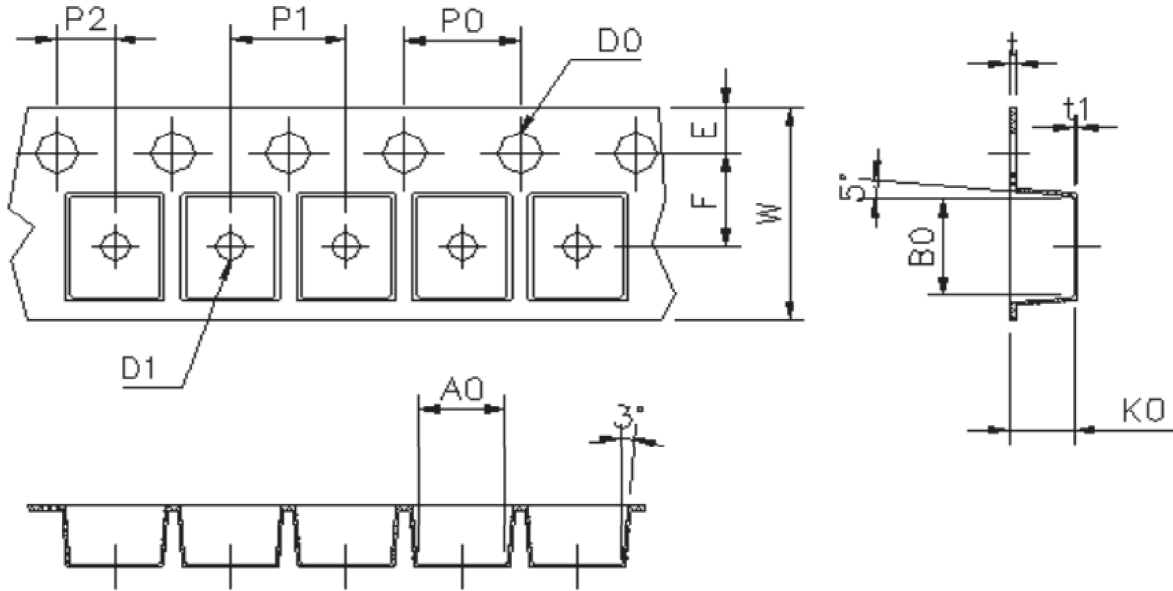

Symbol	Spec	Symbol	Spec
<b>W</b>	12.00±0.10	<b>A<sub>0</sub></b>	7.00±0.10
<b>E</b>	1.75±0.10	<b>B<sub>0</sub></b>	7.27±0.10
<b>F</b>	5.50±0.10	<b>K<sub>0</sub></b>	1.85±0.10
<b>D<sub>0</sub></b>	1.50 (+0.10; -0)	<b>10*p<sub>0</sub></b>	40.00±0.20
<b>D<sub>1</sub></b>	1.50 (+0.10; -0)		
<b>P<sub>0</sub></b>	4.00±0.10		
<b>P<sub>1</sub></b>	8.00±0.10		
<b>P<sub>2</sub></b>	2.00±0.10		
<b>t</b>	0.25-0.28		
<b>t<sub>1</sub></b>	0.05		



## MSL (Moisture Sensitive Level) Information

IPC/JEDEC J-STD-020D.1 Moisture Sensitivity Levels Table

LEVEL	FLOOR LIFE		SOAK REQUIREMENTS				
			Standard		Accelerated Equivalent <sup>1</sup>		
					eV 0.40-0.48	eV 0.30-0.39	CONDITION
TIME	CONDITION	TIME (hours)	CONDITION	TIME (hours)	TIME (hours)		
1	Unlimited	≤30 °C /85% RH	168 +5/-0	85 °C /85% RH	NA	NA	NA
2	1 year	≤30 °C /60% RH	168 +5/-0	85 °C /60% RH	NA	NA	NA
2a	4 weeks	≤30 °C /60% RH	696 <sup>2</sup> +5/-0	30 °C /60% RH	120 -1/+0	168 -1/+0	60 °C/ 60% RH
3	168 hours	≤30 °C /60% RH	192 <sup>2</sup> +5/-0	30 °C /60% RH	40 -1/+0	52 -1/+0	60 °C/ 60% RH
4	72 hours	≤30 °C /60% RH	96 <sup>2</sup> +2/-0	30 °C /60% RH	20 +0.5/-0	24 +0.5/-0	60 °C/ 60% RH
5	48 hours	≤30 °C /60% RH	72 <sup>2</sup> +2/-0	30 °C /60% RH	15 +0.5/-0	20 +0.5/-0	60 °C/ 60% RH
a	24 hours	≤30 °C /60% RH	48 <sup>2</sup> +2/-0	30 °C /60% RH	10 +0.5/-0	13 +0.5/-0	60 °C/ 60% RH
6	Time on Label (TOL)	≤30 °C /60% RH	TOL	30 °C /60% RH	NA	NA	NA

**Note 1:** CAUTION - To use the “accelerated equivalent” soak conditions, correlation of damage response (including electrical, after soak and reflow), should be established with the “standard” soak conditions. Alternatively, if the known activation energy for moisture diffusion of the package materials is in the range of 0.40 - 0.48 eV or 0.30 - 0.39 eV, the “accelerated equivalent” may be used. Accelerated soak times may vary due to material properties (e.g .mold compound, encapsulant, etc.). JEDEC document JESD22-A120 provides a method for determining the diffusion coefficient.

**Note 2:** The standard soak time includes a default value of 24 hours for semiconductor manufacturer’s exposure time (MET) between bake and bag and includes the maximum time allowed out of the bag at the distributor’s facility. If the actual MET is less than 24 hours the soak time may be reduced. For soak conditions of 30 °C/60% RH, the soak time is reduced by 1 hour for each hour the MET is less than 24 hours. For soak conditions of 60 °C/60% RH, the soak time is reduced by 1 hour for each 5 hours the MET is less than 24 hours. If the actual MET is greater than 24 hours the soak time must be increased. If soak conditions are 30 °C/60% RH, the soak time is increased 1 hour for each hour that the actual MET exceeds 24 hours. If soak conditions are 60 °C/60% RH, the soak time is increased 1 hour for each 5 hours that the actual MET exceeds 24 hours.



## X-ON Electronics

Largest Supplier of Electrical and Electronic Components

*Click to view similar products for [Linear Voltage Regulators](#) category:*

*Click to view products by [Shenzhen JingYang](#) manufacturer:*

Other Similar products are found below :

[LV5684PVD-XH](#) [MCDTSA6-2R](#) [L7815ACV-DG](#) [714954EB](#) [ZMR500QFTA](#) [BA033LBSG2-TR](#) [LV5680P-E](#) [L79M05T-E](#) [L78LR05D-MA-E](#) [NCV317MBTG](#) [NTE7227](#) [MP2018GZD-33-P](#) [MP2018GZD-5-P](#) [LV5680NPVC-XH](#) [LT1054CN8](#) [ZTS6538SE](#) [UA78L09CLP](#) [UA78L09CLPR](#) [CAT6221-PPTD-GT3](#) [MC78M09CDTRK](#) [NCV51190MNTAG](#) [78M05](#) [HT7150-1](#) [UM1540DB-18](#) [XC6234H281VR-G](#) [WL2834CA-6/TR](#) [TPL730F33-5TR](#) [TLS850F1TA](#) [V50](#) [TPS549B22RVFR](#) [UM1540DB-33](#) [WL9200P3-50B](#) [WL9100P3-33B](#) [WL9005D4-33](#) [XC6219B152MR](#) [WL2855K33-3/TR](#) [PJ54BM33SE](#) [PJ9500M25SA](#) [MD7218E33PC1](#) [H7533-2PR](#) [SK7812AU](#) [SD1A30](#) [78L33](#) [TP78L33T3](#) [L78L33ACUTR](#) [SK6513ST3A-50](#) [SK6054D4-09](#) [SK6054D4-18](#) [SK6054D4-11](#) [SK6054D4-10](#) [LM79L12F](#)