

N-Channel Trench Power MOSFET

General Description

The JY2312X uses advanced trench technology to provide excellent $R_{DS(ON)}$, low gate charge and operation with gate voltages as low as 2.5V. This device is suitable for use as a battery protection or in other switching application.

Features

- $V_{DS} = 20V, I_D = 6A$
 $R_{DS(ON)} < 26m\Omega @ V_{GS} = 4.5V$
 $R_{DS(ON)} < 34m\Omega @ V_{GS} = 2.5V$
- High Power and current handing capability
- Lead free product is acquired
- Surface Mount Package

Application

- Battery protection
- Load switch
- Power management

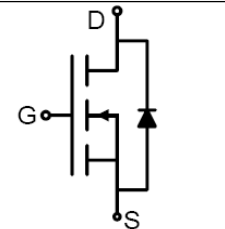

Schematic Diagram

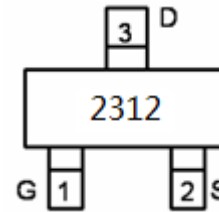

Marking and pin Assignment

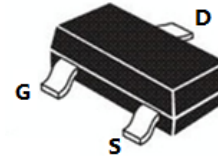

SOT23 top view

Package Marking and Ordering Information

Device Marking	Device	Device Package	Reel Size	Tape width	Quantity
2312	JY2312X	SOT23	Ø180mm	8mm	3000 units

Table 1. Absolute Maximum Ratings ($T_A=25^\circ C$)

Symbol	Parameter	Value	Unit
V_{DS}	Drain-Source Voltage ($V_{GS}=0V$)	20	V
V_{GS}	Gate-Source Voltage ($V_{DS}=0V$)	± 12	V
I_D	Drain Current-Continuous	6	A
$I_{DM (pluse)}$	Drain Current-Continuous@ Current-Pulsed (Note 1)	16	A
P_D	Maximum Power Dissipation	1.3	W
T_J, T_{STG}	Operating Junction and Storage Temperature Range	-55 To 150	$^\circ C$

Notes 1.Repetitive Rating: Pulse width limited by maximum junction temperature

Table 2. Thermal Characteristic

Symbol	Parameter	Value	Unit
$R_{\theta JA}$	Thermal Resistance, Junction-to-Ambient	96	$^\circ C/W$

Table 3. Electrical Characteristics (T_A=25°C unless otherwise noted)

Symbol	Parameter	Conditions	Min	Typ	Max	Unit
On/Off States						
B _V DSS	Drain-Source Breakdown Voltage	V _{GS} =0V, I _D =250μA	20	22		V
I _{DSS}	Zero Gate Voltage Drain Current	V _{DS} =20V, V _{GS} =0V			1	μA
I _{GSS}	Gate-Body Leakage Current	V _{GS} =±12V, V _{DS} =0V			±100	nA
V _{GS(th)}	Gate Threshold Voltage	V _{DS} =V _{GS} , I _D =250μA	0.5	0.7	1.1	V
g _{FS}	Forward Transconductance	V _{DS} =5V, I _D =5A	4	8		S
R _{DS(ON)}	Drain-Source On-State Resistance	V _{GS} =4.5V, I _D =5A		18	26	mΩ
		V _{GS} =2.5V, I _D =4A		23	34	mΩ
Dynamic Characteristics						
C _{iss}	Input Capacitance	V _{DS} =10V, V _{GS} =0V, f=1.0MHz		500		pF
C _{oss}	Output Capacitance			300		pF
C _{rss}	Reverse Transfer Capacitance			140		pF
Switching Times						
t _{d(on)}	Turn-on Delay Time	V _{DD} =10V, I _D =1A, R _L =2.8Ω V _{GS} =4.5V, R _G =6Ω		20		nS
t _r	Turn-on Rise Time			19		nS
t _{d(off)}	Turn-Off Delay Time			65		nS
t _f	Turn-Off Fall Time			25		nS
Q _g	Total Gate Charge	V _{DS} =10V, I _D =5A, V _{GS} =4.5V		10		nC
Q _{gs}	Gate-Source Charge			2.3		nC
Q _{gd}	Gate-Drain Charge			2.9		nC
Source-Drain Diode Characteristics						
I _{SD}	Source-Drain Current(Body Diode)				5	A
V _{SD}	Forward on Voltage ^(Note 1)	V _{GS} =0V, I _S =5A			1.2	V

Notes 1. Repetitive Rating: Pulse width limited by maximum junction temperature.

Switch Time Test Circuit and Switching Waveforms:

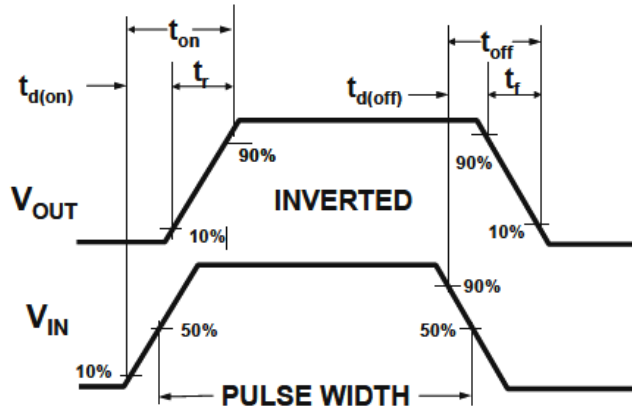
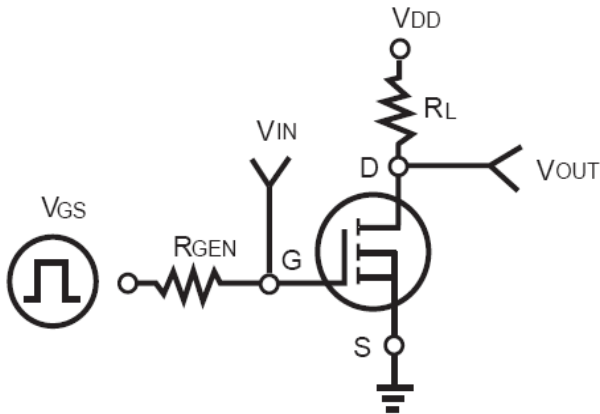

TYPICAL ELECTRICAL AND THERMAL CHARACTERISTICS (Curves)

Figure1. Power Dissipation

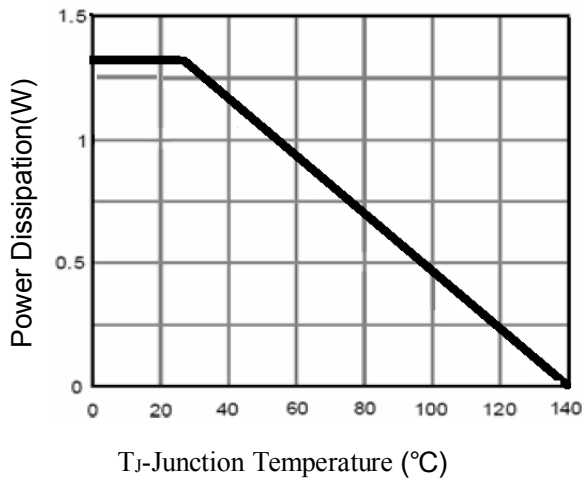

Figure2. Drain Current

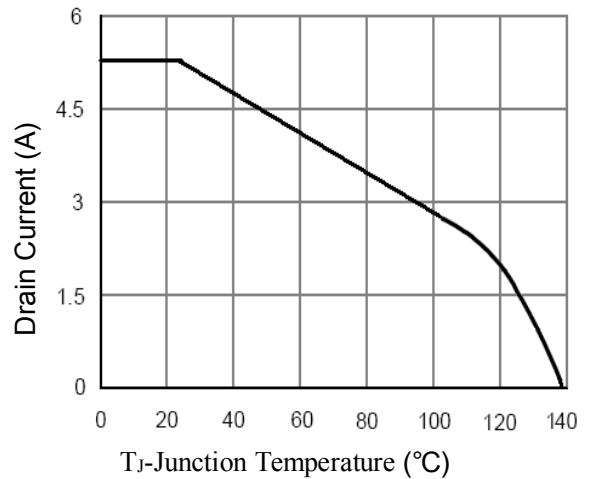

Figure3. Output Characteristics

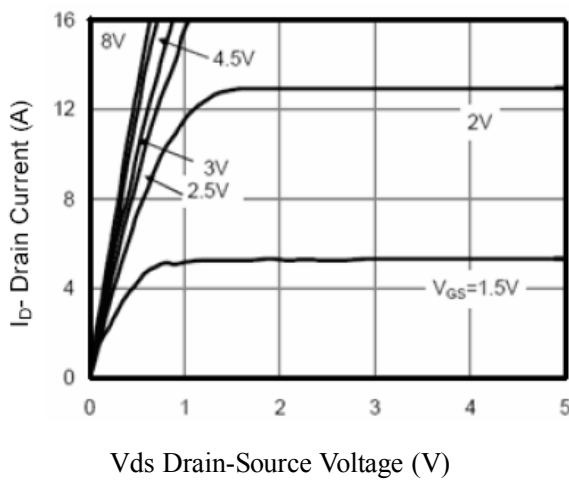

Figure4. Transfer Characteristics

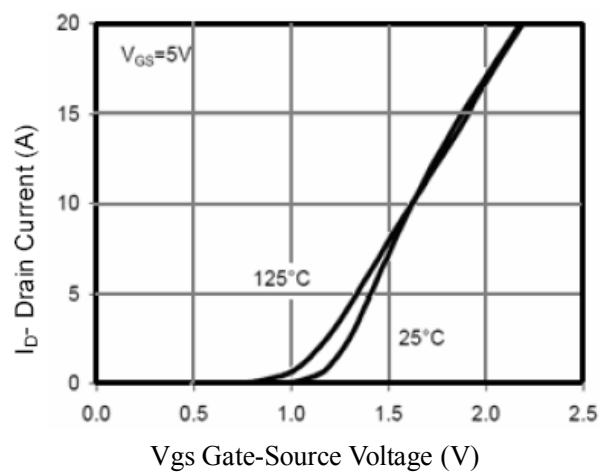

Figure5. Capacitance

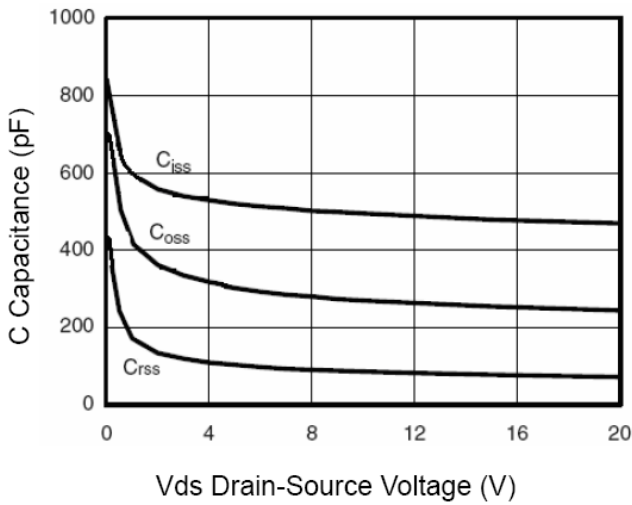

Figure6. $R_{DS(ON)}$ vs Junction Temperature

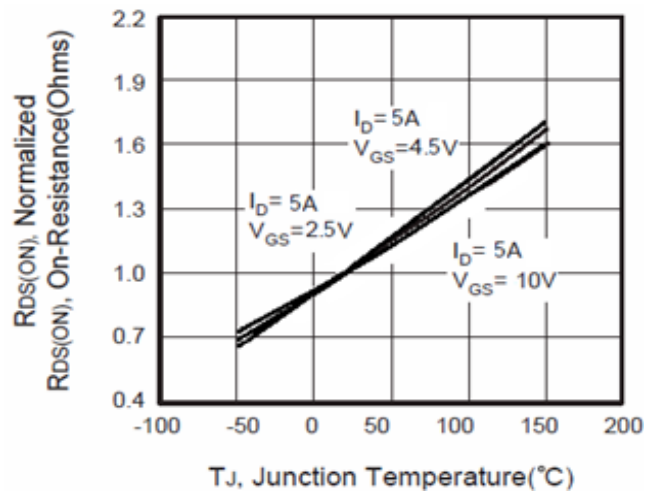

Figure7. Max BV_{DSS} vs Junction Temperature

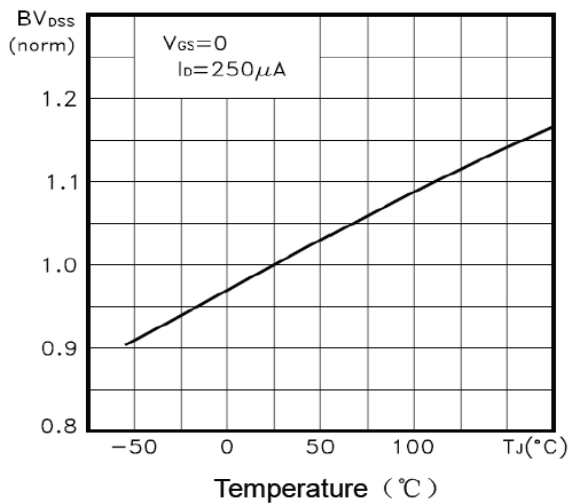

Figure8. $V_{GS(th)}$ vs Junction Temperature

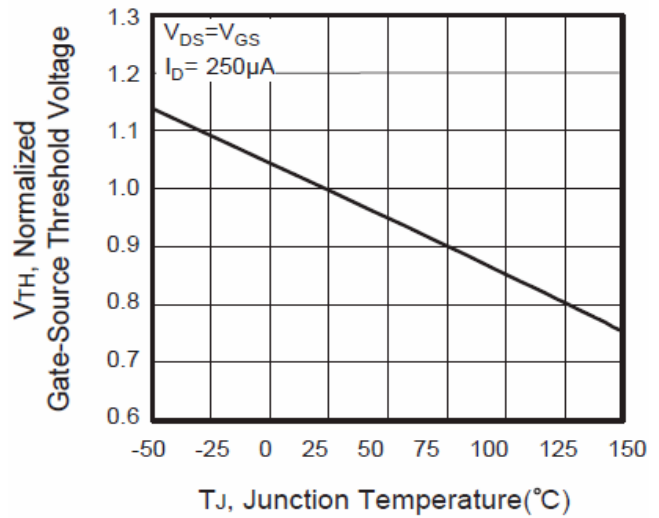

Figure9. Gate Charge Waveforms

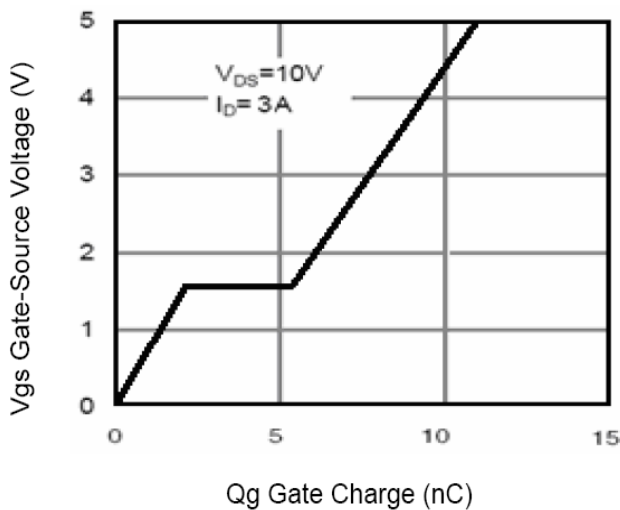

Figure10. Maximum Safe Operating Area

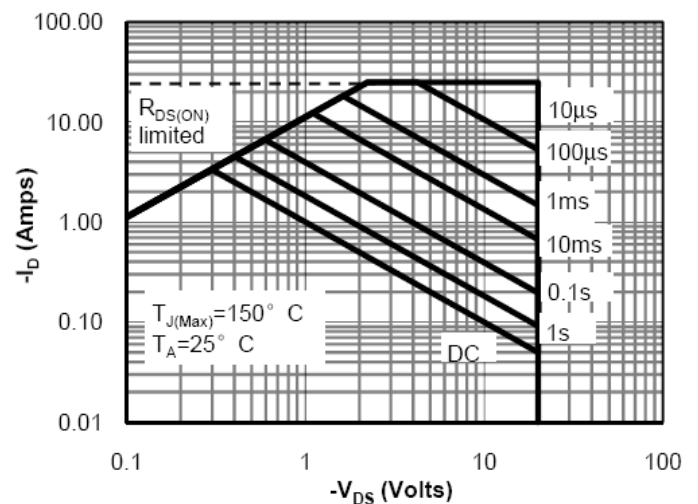
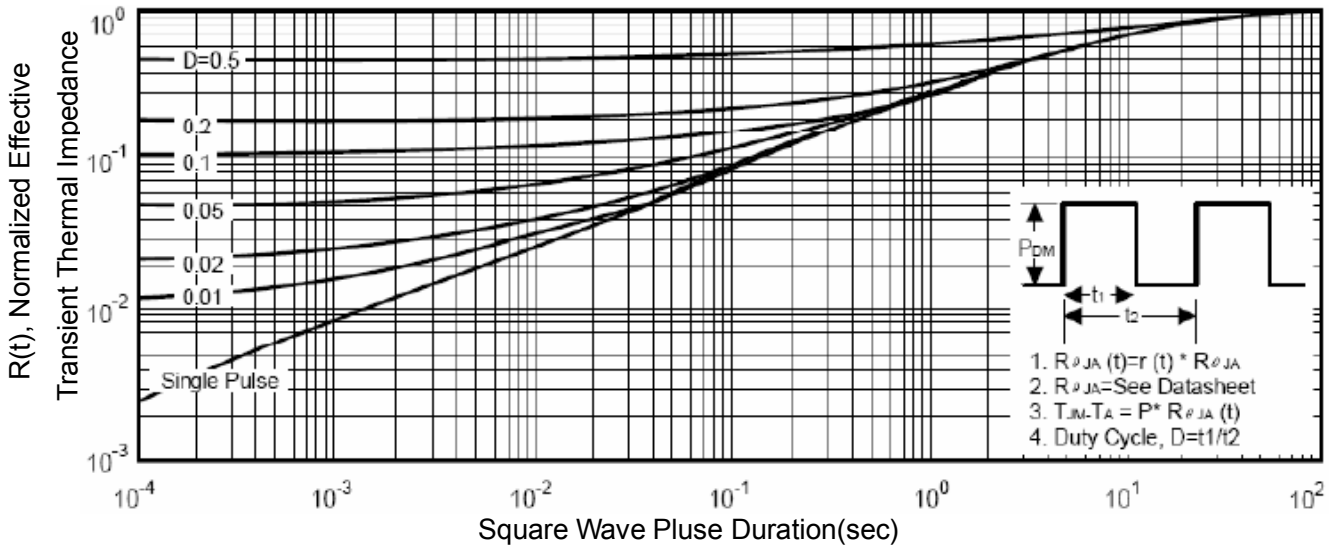
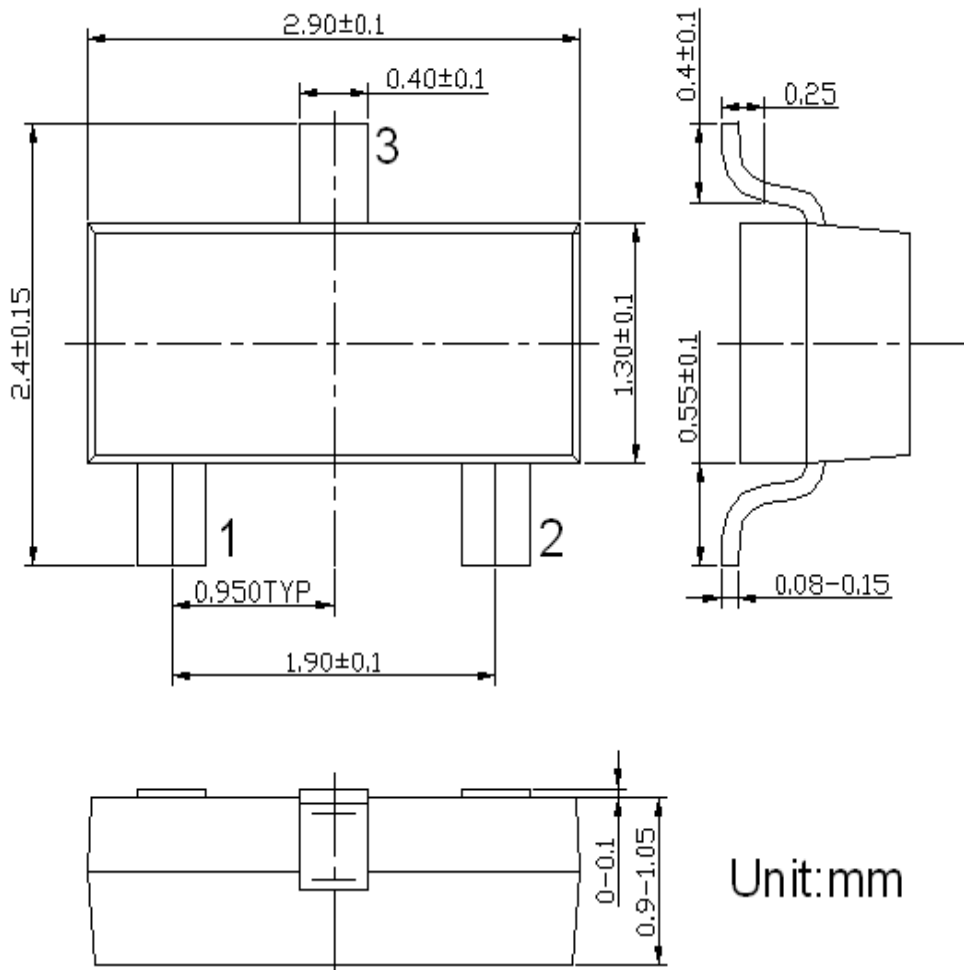

Figure11. Normalized Maximum Transient Thermal Impedance

SOT23 Package Information



Carrier Dimensions

PKG TYPE	W	P	E	F	D	D1	Po	Po10	P2
SOT23	8.00	4.00	1.75	3.50	1.50	1.00	4.00	40.00	2.00
Tolerance	+0.3/-0.1	±0.1	±0.1	±0.1	±0.1	±0.1	±0.1	±0.2	±0.05

A0	B0	K0	T
3.15	2.77	1.22	0.20
±0.1	±0.1	±0.1	±0.02

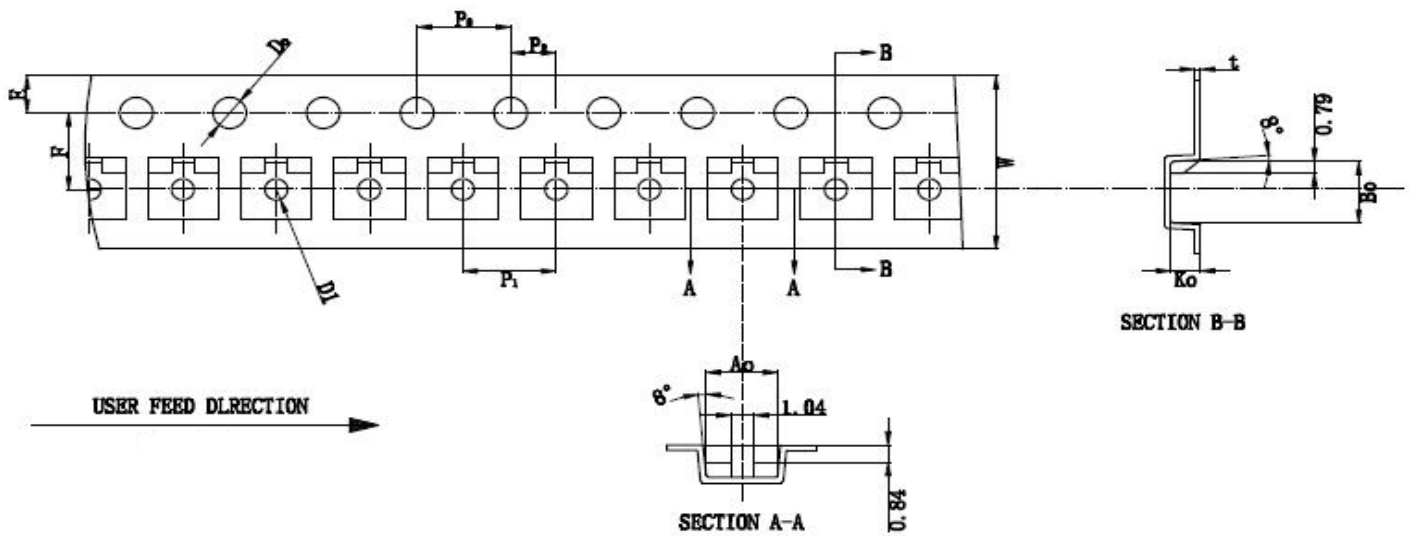

X-ON Electronics

Largest Supplier of Electrical and Electronic Components

Click to view similar products for [MOSFET](#) category:

Click to view products by [Shenzhen JingYang](#) manufacturer:

Other Similar products are found below :

[IRFD120](#) [JANTX2N5237](#) [BUK455-60A/B](#) [MIC4420CM-TR](#) [VN1206L](#) [NDP4060](#) [SI4482DY](#) [IPS70R2K0CEAKMA1](#) [SQD23N06-31L-GE3](#)
[TK16J60W,S1VQ\(O](#) [2SK2614\(TE16L1,Q\)](#) [DMN1017UCP3-7](#) [DMN1053UCP4-7](#) [SQJ469EP-T1-GE3](#) [NTE2384](#) [DMC2700UDMQ-7](#)
[DMN2080UCB4-7](#) [DMN61D9UWQ-13](#) [US6M2GTR](#) [DMN31D5UDJ-7](#) [DMP22D4UFO-7B](#) [DMN1006UCA6-7](#) [DMN16M9UCA6-7](#)
[STF5N65M6](#) [IRF40H233XTMA1](#) [STU5N65M6](#) [DMN6022SSD-13](#) [DMN13M9UCA6-7](#) [DMTH10H4M6SPS-13](#) [DMN2990UFB-7B](#)
[IPB80P04P405ATMA2](#) [2N7002W-G](#) [MCAC30N06Y-TP](#) [MCQ7328-TP](#) [NTMC083NP10M5L](#) [NVMFS2D3P04M8LT1G](#) [BXP7N65D](#)
[BXP4N65F](#) [AOL1454G](#) [WMJ80N60C4](#) [BXP2N20L](#) [BXP2N65D](#) [BXT1150N10J](#) [BXT1700P06M](#) [TSM60NB380CP](#) [ROG](#) [RQ7L055BGTCR](#)
[DMNH15H110SK3-13](#) [SLF10N65ABV2](#) [BSO203SP](#) [BSO211P](#)