



### Features

- ❑ IEC61000-4-2 (ESD) +/-30kV (air),  
+/-30KV(contact)
- IEC61000-4-4 (EFT) 40A (5/50ns)
- IEC61000-4-5 (EOS) 30A(1.2/50uS, 8/20uS)
- ❑ Peak Pulse Current(tp=8/20us) 450W
- ❑ Protects one I/O line (bidirectional)
- ❑ Working voltages : 3.3V
- ❑ Low leakage current
- ❑ ROHS compliant

### Description

The PESD3V3L1BA is designed for applications requiring transient overvoltage protection capability. They are intended for use in voltage and ESD sensitive equipment such as computers, printers, business machines, communication systems, medical equipment and other applications. These devices are ideal for situations where board space is at a premium.

This series has been specifically designed to protect sensitive components which are connected to power data and transmission lines from overvoltage caused by ESD(electrostatic discharge), CDE (Cable Discharge Events), and EFT (electrical fast transients).

### Applications

- ❑ Cell Phone Handsets and Accessories
- ❑ Microprocessor based equipment
- ❑ Personal Digital Assistants (PDA's)
- ❑ Notebooks, Desktops, and Servers
- ❑ Portable Instrumentation
- ❑ Networking and Telecom
- ❑ Serial and Parallel Ports.
- ❑ Peripherals

### Mechanical Characteristics

- ❑ SOD-323 package
- ❑ Flammability Rating: UL 94V-0
- ❑ Packaging: Tape and Reel
- ❑ High temperature soldering guaranteed:260°C/10s
- ❑ Reel size: 7 inch

### Circuit Diagram



### Pin Configuration

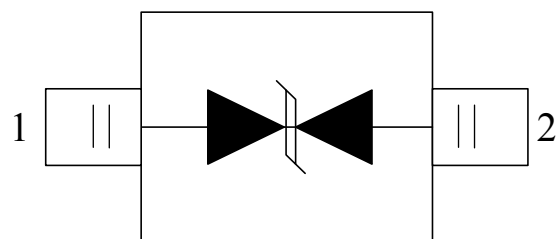

SOD-323  
(Top View)



**Absolute Maximum Rating**

Symbol	Parameter	Value	Units
$I_{PP}$	Peak Pulse Current (8/20 $\mu$ s)	30	A
$P_{PK}$	Peak Pulse Power (8/20 $\mu$ s)	450	Watts
$V_{ESD}$	ESD per IEC 61000-4-2 (Air) ESD per IEC 61000-4-2 (Contact)	$\pm 30$ $\pm 30$	kV
$T_{OPT}$	Operating Temperature	-55 to +125	$^{\circ}$ C
$T_{STG}$	Storage Temperature	-55 to +150	$^{\circ}$ C

**Electrical Characteristics (T = 25 $^{\circ}$ C)**

Symbol	Parameter
$V_{RWM}$	Nominal Reverse Working Voltage
$I_R$	Reverse Leakage Current @ $V_{RWM}$
$V_{BR}$	Reverse Breakdown Voltage @ $I_T$
$I_T$	Test Current for Reverse Breakdown
$V_C$	Clamping Voltage @ $I_{PP}$
$I_{PP}$	Maximum Peak Pulse Current
$C_{ESD}$	Parasitic Capacitance
$V_R$	Reverse Voltage
f	Small Signal Frequency

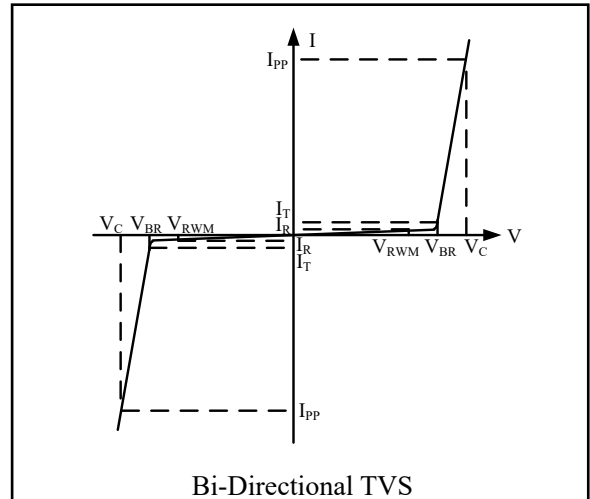

Symbol	Test Condition	Minimum	Typical	Maximum	Units
$V_{RWM}$				3.3	V
$I_R$	$V_{RWM} = 3.3, T = 25^{\circ}C$ Between I/O_1 and I/O_2		0.1	1.0	$\mu$ A
$V_{BR}$	$I_T = 1mA$ Between I/O_1 and I/O_2	3.6			V
$V_C$	$I_{PP} = 30A, t_p = 8/20\mu s$ Between I/O_1 and I/O_2			15	V
$C_{ESD}$	$V_R = 0V, f = 1MHz$ Between I/O_1 and I/O_2		40	80	pF

### Typical Characteristics

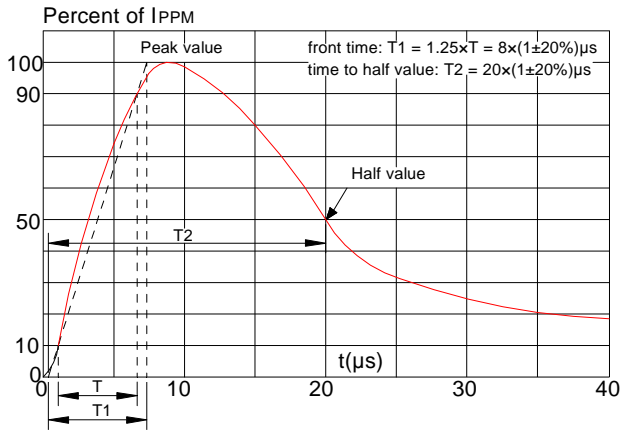

Fig 1. Pulse Waveform

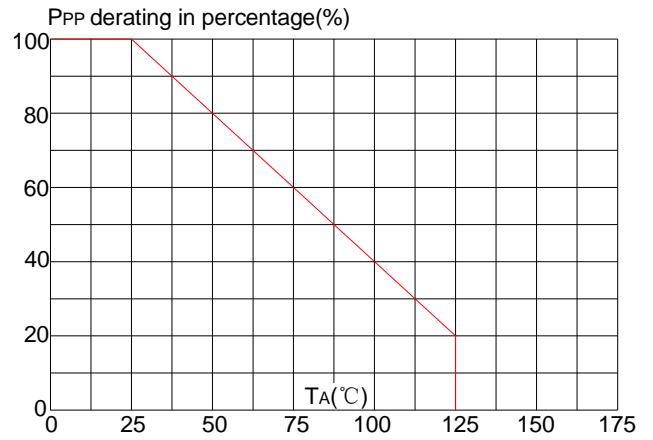
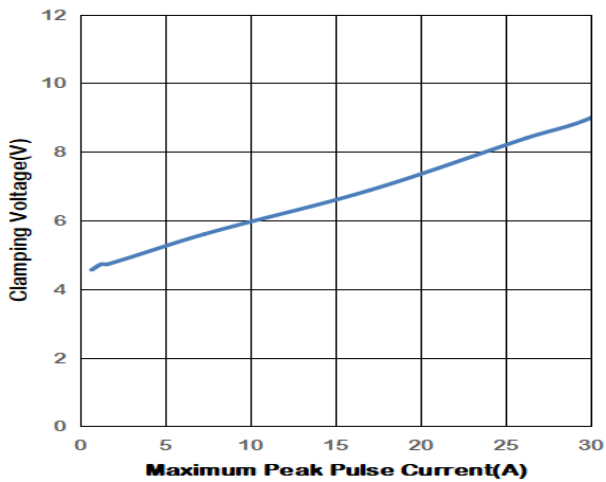

Fig 2. Power Derating Curve

### IEC61000-4-5 EOS Test (1.2/50uS, 8/20uS)





**SOLDERING PARAMETERS**

Reflow Condition		Pb-Free assembly (see figure at right)
Pre Heat	-Temperature Min ( $T_{s(min)}$ )	+150°C
	-Temperature Max( $T_{s(max)}$ )	+200°C
	-Time (Min to Max) ( $t_s$ )	60-180 secs.
Average ramp up rate (Liquidus Temp ( $T_L$ ) to peak)		3°C/sec. Max
$T_{s(max)}$ to $T_L$ - Ramp-up Rate		3°C/sec. Max
Reflow	-Temperature( $T_L$ )(Liquidus)	+217°C
	-Temperature( $t_L$ )	60-150 secs.
Peak Temp ( $T_P$ )		+260(+0/-5)°C
Time within 5°C of actual Peak Temp ( $t_p$ )		20-40secs.
Ramp-down Rate		6°C/sec. Max
Time 25°C to Peak Temp ( $T_P$ )		8 min. Max
Do not exceed		+260°C

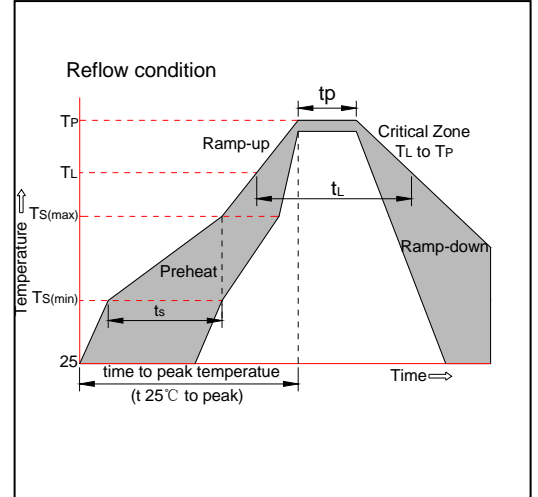

**Package Outline**

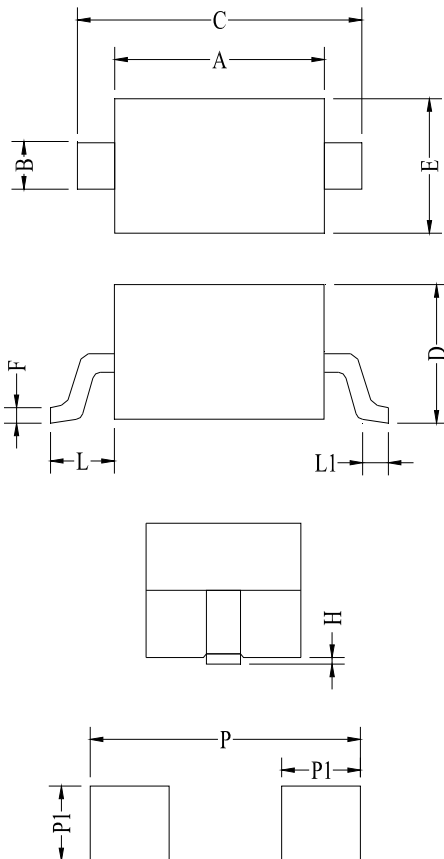

**Land Pattern**

Symbol	Millimeters			Inches		
	Min	Typ	Max	Min	Typ	Max
A	1.60	1.70	1.80	0.063	0.067	0.071
B	0.25	0.32	0.40	0.010	0.013	0.016
C	2.30	2.60	2.80	0.091	0.102	0.110
D	0.80	0.95	1.10	0.031	0.037	0.043
E	1.20	1.30	1.40	0.047	0.051	0.055
F	0.08	0.13	0.18	0.003	0.005	0.007
L	0.475REF			0.019REF		
L1	0.25	0.33	0.40	0.010	0.013	0.016
H	0.00	0.06	0.14	0.000	0.002	0.006
P	3.00			0.118		
P1	0.80			0.031		



**Tape and Reel Specification**

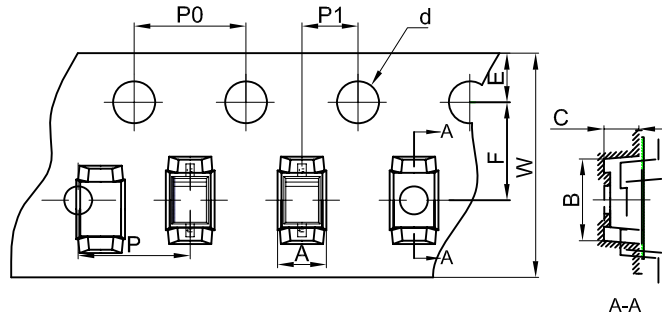

Dimensions are in millimeter										
Pkg type	A	B	C	d	E	F	P0	P	P1	W
SOD-323	1.46	2.90	1.25	Ø1.50	1.75	3.50	4.00	4.00	2.00	8.00
(Tolerance)	+/-0.05	+/-0.05	+/-0.05	+/-0.1	+/-0.1	+/-0.1	+/-0.1	+/-0.1	+/-0.1	+0.3/-0.1

**SOD-323 Tape Leader and Trailer**

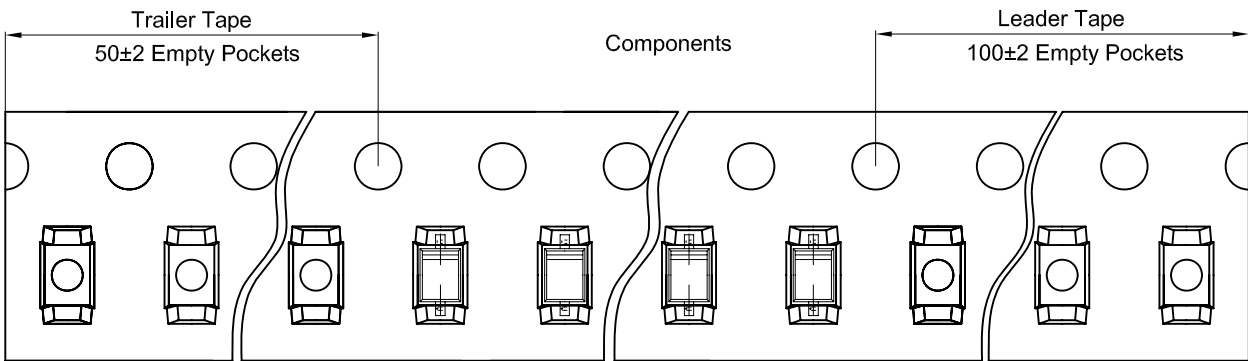

**SOD-323 Reel**

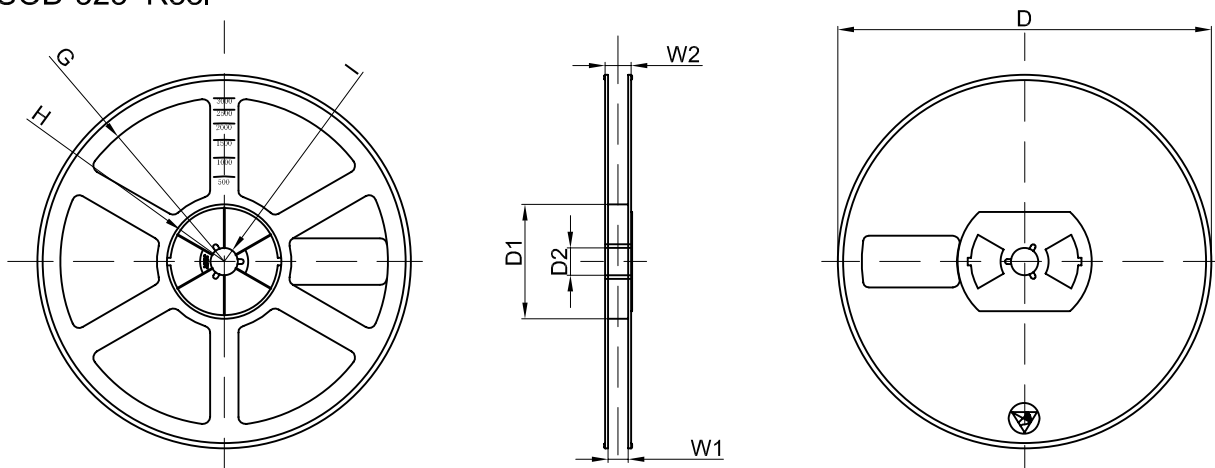

Dimensions are in millimeter								
Reel Option	D	D1	D2	G	H	I	W1	W2
7" Dia	Ø178.00	54.40	13.00	R78.00	R25.60	R6.50	9.50	12.30
Tolerance	+/-2	+/-1	+/-1	+/-1	+/-1	+/-1	+/-1	+/-1

REEL	Reel Size	Box	Box Size(mm)	Carton	Carton Size(mm)	G.W.(kg)
3000 pcs	7 inch	45,000 pcs	203×203×195	180,000 pcs	438×438×220	



**Ordering Information**

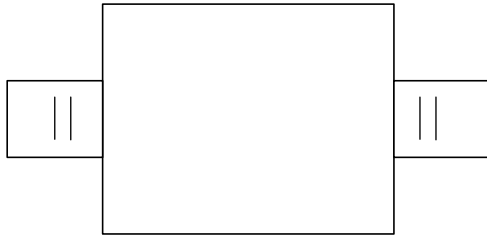

Part Number	Working Voltage	Quantity Per Reel	Reel Size
PESD3V3L1BA	3.3V	3,000	7 Inch

## X-ON Electronics

Largest Supplier of Electrical and Electronic Components

*Click to view similar products for [ESD Suppressors / TVS Diodes](#) category:*

*Click to view products by [Shenzhen JingYang](#) manufacturer:*

Other Similar products are found below :

[60KS200C](#) [D18V0L1B2LP-7B](#) [D5V0F4U5P5-7](#) [NTE4902](#) [P4KE27CA](#) [P6KE11CA](#) [P6KE8.2A](#) [SA60CA](#) [SA64CA](#) [SMBJ12CATR](#)  
[SMBJ33CATR](#) [SMBJ6.5A](#) [SMBJ8.0A](#) [ESD101-B1-02ELS E6327](#) [ESD112-B1-02EL E6327](#) [ESD7451N2T5G](#) [19180-510](#) [CPDT-5V0USP-](#)  
[HF](#) [3.0SMCJ33CA-F](#) [3.0SMCJ36A-F](#) [HSPC16701B02TP](#) [JANTX1N6126A](#) [D3V3Q1B2DLP3-7](#) [D55V0M1B2WS-7](#) [SCM1293A-04SO](#)  
[ESD200-B1-CSP0201 E6327](#) [SM12-7](#) [CEN955 W/DATA](#) [VESD12A1A-HD1-GS08](#) [CPDQC5V0-HF](#) [D1213A-01LP4-7B](#) [ESD101-B1-02EL](#)  
[E6327](#) [AOZ8808DI-03](#) [5KP15A](#) [5KP48A](#) [5KP90A](#) [ESD3V3D7-TP](#) [15KPA36A-LF](#) [P4KE56CA](#) [P4KE68A](#) [P4KE91CATR](#) [P6KE120A](#)  
[P6KE13CA](#) [P6KE43CA](#) [P6KE6.8CA](#) [P6KE8.2](#) [P6SMBJ20CA](#) [JANTX1N6072A](#) [SR2835ESKG](#) [SA90CA](#)