



### Features

- 2A Output Current
- Wide 4.5V to 27V Operating Input Range
- Integrated Power MOSFET switches
- Output Adjustable from 0.925V to 0.8Vin
- Up to 96% Efficiency
- Programmable Soft-Start
- Stable with Low ESR Ceramic Output Capacitors
- Fixed 340KHZ Frequency
- Cycle-by-Cycle Over Current Protection
- Short Circuit Protection
- Input Under Voltage Lockout
- Package : SOP-8L

### General Description

The TD8202 is a monolithic synchronous buck regulator. The device integrates 95 mΩ MOSFETS that provide 2A continuous load current over a wide operating input voltage of 4.5V to 27V. Current mode control provides fast transient response and cycle-by-cycle current limit. An adjustable soft-start prevents inrush current at turn on.

### Applications

- Distributed Power Systems
- Networking Systems
- FPGA, DSP, ASIC Power Supplies
- Green Electronics/ Appliances
- Notebook Computers

### Typical Application Circuit

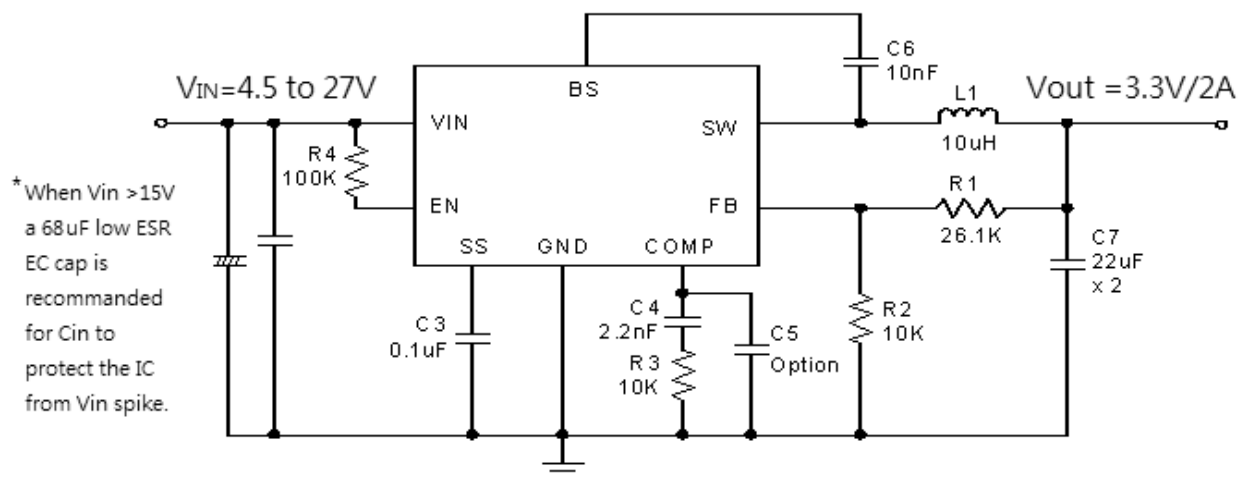



### Ordering Information

#### TD8202-X X X

Output Voltage :  
Blank : ADJ

Package :  
S8 : SOP-8L

Packing :  
A : Tape & Reel

Part Number	Package Code	Package	Tape & Reel	
			Quantity	Part Number Suffix
TD8202-S8A	S8	SOP-8L	3000	A

### Pin Assignments

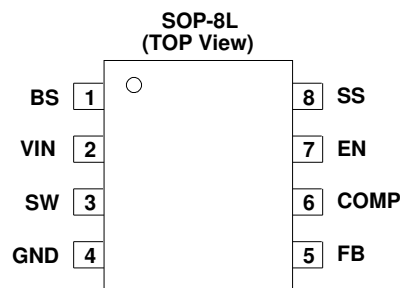

### Pin Descriptions

Pin Number	Name	Description
1	BS	Bootstrap. This pin acts as the positive rail for the high-side switch's gate driver. Connect a 0.01uF capacitor between BS and SW.
2	VIN	Input Supply. Bypass this pin to GND with a low ESR capacitor. See Input Capacitor in the Application Information section.
3	SW	Switch Output. Connect this pin to the switching end of the inductor.
4	GND	Ground.
5	FB	Feedback Input. The voltage at this pin is regulated to 0.925V. Connect to the resistor divider between output and ground to set output voltage.
6	COMP	Compensation Pin. See Stability Compensation in the Application Information section.
7	EN	Enable Input. When higher than 2.7V, this pin turns the IC on. When lower than 1.1V, this pin turns the IC off. Output voltage is discharged when the IC is off. This pin should not be left open. Recommend to put a 100KΩ pull up resistor to Vin for start up.
8	SS	Soft-Start Control Input. SS controls the soft-start period. Connect a capacitor from SS to GND to set the soft-start period. A 0.1uF capacitor sets the soft-start period to 15ms. To disable the soft-start feature, leave SS unconnected.



### Block Diagram

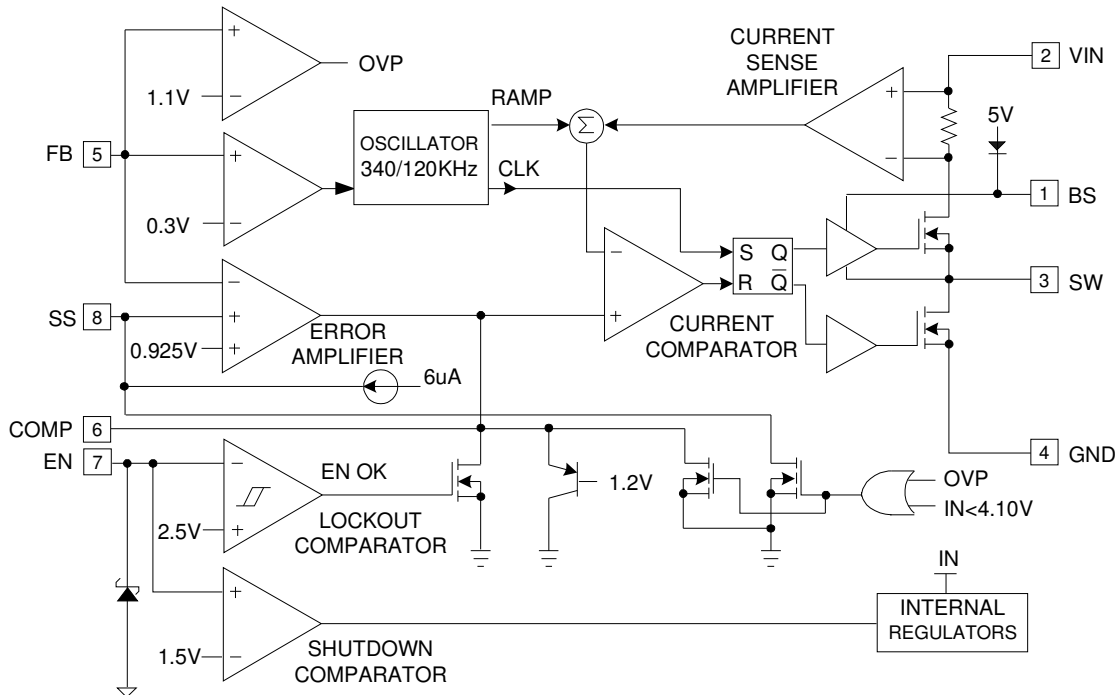

### Absolute Maximum Ratings

Parameter	Value	Unit
Input Supply Voltage	-0.3 to 30	V
SW Voltage	-0.3 to $V_{IN} + 0.3$	V
BS Voltage	$V_{SW} - 0.3$ to $V_{SW} + 6$	V
EN, FB, COMP Voltage	-0.3 to 5.	V
Continuous SW Current	Internally limited	A
Junction to Ambient Thermal Resistance ( $\theta_{JA}$ ) (Test on Approximately 3 in <sup>2</sup> Copper Area 1oz copper FR4 board)	87	°C/W
SOP-8L Power Dissipation	Internal limit	W
Maximum Junction Temperature	150	°C
Storage Temperature Range	-65 to 150	°C
Moisture Sensitivity (MSL)	Please refer the MSL label on the IC package bag/carton for detail	

(Note: Exceeding these limits may damage the device., Even the duration of exceeding is very short. Exposure to absolute maximum rating conditions for long periods may affect device reliability.)

**Recommended Operating Conditions**

Parameter	Min	Max	Unit
Input Supply Voltage	4.5	27 <sup>(1)</sup>	V
Operating Junction Temperature	-20	+125 <sup>(2)</sup>	°C

(Note (1): Operating the IC over this voltage is very easy to cause over voltage condition to VIN pin, SW pin, BS pin & EN pin)

(Note (2): If the IC experienced OTP, then the temperature may need to drop to <125 degree C to let the IC recover.)

**Electrical Characteristics**

(V<sub>IN</sub> = 12V, T<sub>A</sub> = 25°C unless otherwise specified.)

Parameter	Symbol	Test Conditions	Min	Typ	Max	Unit
Feedback Voltage	V <sub>FB</sub>	4.5V ≤ V <sub>IN</sub> ≤ 27V	0.900	0.925	0.950	V
Feedback Overvoltage Threshold				1.1		V
High-Side Switch-On Resistance*				95		mΩ
Low-Side Switch-On Resistance*				95		mΩ
High-Side Switch Leakage		V <sub>EN</sub> = 0V, V <sub>SW</sub> = 0V			10	uA
Upper Switch Current Limit*		Minimum Duty Cycle	2.7	3.5		A
COMP to Current Limit Transconductance	G <sub>COMP</sub>			3.3		A/V
Error Amplifier Transconductance	G <sub>EA</sub>	ΔI <sub>COMP</sub> = ±10uA		920		uA/V
Error Amplifier DC Gain*	A <sub>VEA</sub>			480		V/V
Switching Frequency	f <sub>SW</sub>			340		KHz
Short Circuit Switching Frequency		V <sub>FB</sub> = 0		120		KHz
Maximum Duty Cycle	D <sub>MAX</sub>	V <sub>FB</sub> = 0.8V		92		%
Minimum On Time*				220		nS
EN Shutdown Threshold Voltage		V <sub>EN</sub> Rising	1.1	1.4	2	V
EN Shutdown Threshold Voltage Hysteresis				180		mV
EN Lockout Threshold Voltage			2.2	2.5	2.7	V
EN Lockout Hysteresis				130		mV
Supply Current in Shutdown		V <sub>EN</sub> = 0		0.3	3.0	uA
IC Supply Current in Operation		V <sub>EN</sub> = 3V, V <sub>FB</sub> = 1.0V		1.3	1.5	mA
Input UVLO Threshold Rising	UVLO	V <sub>EN</sub> Rising	3.80	4.05	4.40	V
Input UVLO Threshold Hysteresis				100		mV
Soft-start Current		V <sub>SS</sub> = 0V		6		uA
Soft-start Period		C <sub>SS</sub> = 0.1uF		15		mS
Thermal Shutdown Temperature*		Hysteresis = 25°C		160		°C

Note: \* Guaranteed by design, not tested



### Application Description

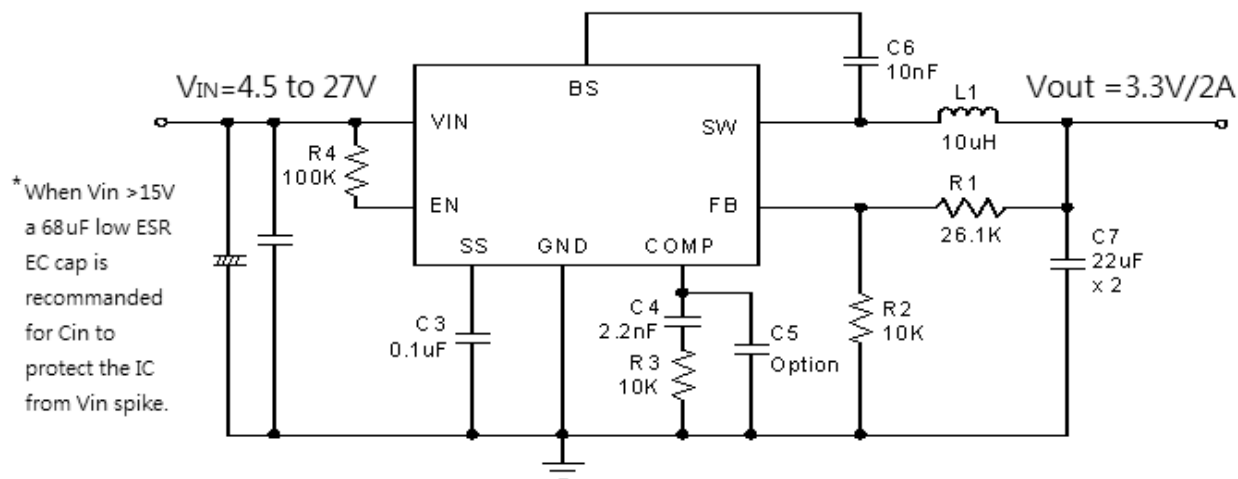

TD8202 Circuit, 3.3V/2A output

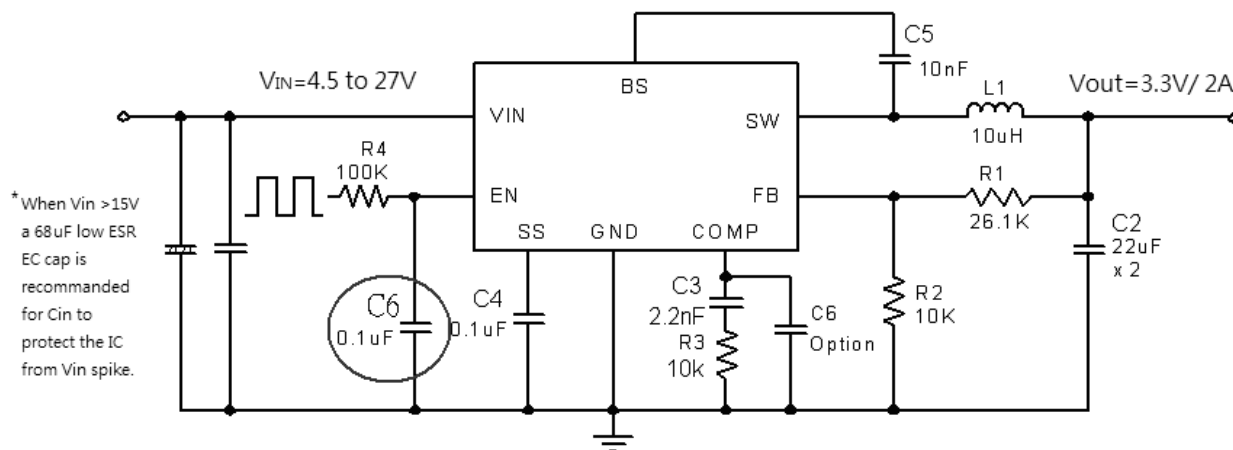

TD8202 Circuit, 3.3V/2A output with EN function

Note: C6 is required for separate EN signal.



### Output Voltage Setting

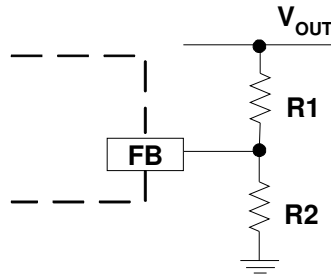

Figure1. Output Voltage Setting

Figure 1 shows the connections for setting the output voltage. Select the proper ratio of the two feedback resistors R1 and R2 based on the output voltage. Typically, use R2 ≈ 10KΩ and determine R1 from the following equation:

$$R1 = R2 \left( \frac{V_{OUT}}{0.925V} - 1 \right) \quad (1)$$

Table1 – Recommended Resistance Values

VOUT	R1	R2
1.0V	1.0 KΩ	12 KΩ
1.2V	3.0 KΩ	10 KΩ
1.8V	9.53 KΩ	10 KΩ
2.5V	16.9 KΩ	10 KΩ
3.3V	26.1 KΩ	10 KΩ
5V	44.2 KΩ	10 KΩ
12V	121 KΩ	10 KΩ

### Inductor Selection

The inductor maintains a continuous current to the output load. This inductor current has a ripple that is dependent on the inductance value: higher inductance reduces the peak-to-peak ripple current. The trade off for high inductance value is the increase in inductor core size and series resistance, and the reduction in current handling capability. In general, select an inductance value L based on the ripple current requirement:

$$L = \frac{V_{OUT} \cdot (V_{IN} - V_{OUT})}{V_{IN} f_{SW} I_{OUTMAX} K_{RIPPLE}} \quad (2)$$

Where V<sub>IN</sub> is the input voltage, V<sub>OUT</sub> is the output voltage, f<sub>SW</sub> is the switching frequency, I<sub>OUTMAX</sub> is the maximum output current, and K<sub>RIPPLE</sub> is the ripple factor. Typically, choose K<sub>RIPPLE</sub> ≈ 30% to correspond to the peak-to-peak ripple current being ~30% of the maximum output current.

With this inductor value, the peak inductor current is I<sub>OUT</sub> • (1 + K<sub>RIPPLE</sub> / 2). Make sure that this peak inductor current is less than the upper switch current limit. Finally, select the inductor core size so that it does not saturate at the current limit. Typical inductor values for various output voltages are shown in Table 2.

V <sub>OUT</sub>	1.0V	1.2V	1.5V	1.8V	2.5V	3.3V	5V	9V
L	4.7uH	4.7uH	10uH	10uH	10uH	10uH	10uH	33uH

Table 2. Typical Inductor Values



### Input Capacitor

The input capacitor needs to be carefully selected to maintain sufficiently low ripple at the supply input of the converter. A low ESR **Electrolytic capacitor** is highly recommended. Since large current flows in and out of this capacitor during switching, its ESR also affects efficiency.

The input capacitance needs to be higher than 68uF. The RMS ripple current rating needs to be higher than 50% of the output current. The input capacitor should be placed close to the VIN and GND pins of the IC, with the shortest traces possible. The input capacitor can be placed a little bit away if a small parallel 0.1uF ceramic capacitor is placed right next to the IC,

**When Vin is >15V, pure ceramic Cin (\* no EC cap) is not recommended.** This is because the ESR of a ceramic cap is often too small, Pure ceramic Cin will work with the parasite inductance of the input trace and forms a Vin resonant tank. When Vin is hot plug in/out, this resonant tank will boost the Vin spike to a very high voltage and damage the IC.

### Output Capacitor

The output capacitor also needs to have low ESR to keep low output voltage ripple. In the case of ceramic output capacitors,  $R_{ESR}$  is very small and does not contribute to the ripple. Therefore, a lower capacitance value can be used for ceramic capacitors. In the case of tantalum or electrolytic capacitors, the ripple is dominated by  $R_{ESR}$  multiplied by the ripple current. In that case, the output capacitor is chosen to have sufficiently low ESR.

For ceramic output capacitors, typically choose of about 22uF. For tantalum or electrolytic capacitors, choose a capacitor with less than 50mΩ ESR.

### Optional Schottky Diode

During the transition between high-side switch and low-side switch, the body diode of the low side power MOSFET conducts the inductor current. The forward voltage of this body diode is high. An optional Schottky diode may be paralleled between the SW pin and GND pin to improve overall efficiency. Table 3 lists example Schottky diodes and their Manufacturers.

Table 3 – Diode Selection Guide

Vin max	Part Number	Voltage/Current Rating	Vendor
<20V	B130	30V, 1A	titan micro
<20V	SS13	30V, 1A	titan micro
>20V	B140	40V, 1A	titan micro
>20V	SS14	30V, 1A	titan micro



### Stability Compensation

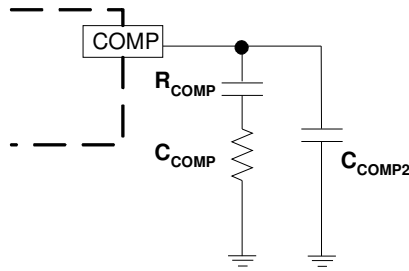

$C_{COMP2}$  is needed only for high ESR output capacitor

**Figure 2. Stability Compensation**

The feedback loop of the IC is stabilized by the components at the COMP pin, as shown in Figure 2. The DC loop gain of the system is determined by the following equation:

$$A_{VDC} = \frac{0.925V}{I_{OUT}} A_{VEA} G_{COMP} \quad (4)$$

The dominant pole P1 is due to  $C_{COMP}$ :

$$f_{P1} = \frac{G_{EA}}{2\pi A_{VEA} C_{COMP}} \quad (5)$$

The second pole P2 is the output pole:

$$f_{P2} = \frac{I_{OUT}}{2\pi V_{OUT} C_{OUT}} \quad (6)$$

The first zero Z1 is due to  $R_{COMP}$  and  $C_{COMP}$ :

$$f_{Z1} = \frac{1}{2\pi R_{COMP} C_{COMP}} \quad (7)$$

And finally, the third pole is due to  $R_{COMP}$  and  $C_{COMP2}$  (if  $C_{COMP2}$  is used):

$$f_{P3} = \frac{1}{2\pi R_{COMP} C_{COMP2}} \quad (8)$$

The following steps should be used to compensate the IC:

**STEP1. Set the crossover frequency at 1/10 of the switching frequency via  $R_{COMP}$ :**

$$R_{COMP} = \frac{2\pi V_{OUT} C_{OUT} f_{SW}}{10 G_{EA} G_{COMP} \cdot 0.925V} \quad (9)$$

but limit  $R_{COMP}$  to 10K $\Omega$  maximum.





**STEP2.** Set the zero  $f_{Z1}$  at 1/4 of the crossover frequency. If  $R_{COMP}$  is less than 10K $\Omega$ , the equation for  $C_{COMP}$  is:

$$C_{COMP} = \frac{0.637}{R_{COMP} \times f_c} (F) \quad (10)$$

**STEP3.** If the output capacitor's ESR is high enough to cause a zero at lower than 4 times the crossover frequency, an additional compensation capacitor  $C_{COMP2}$  is required. The condition for using  $C_{COMP2}$  is:

$$\pi \times C_{OUT} \times R_{ESR} \times f_s \geq 1 \quad (11)$$

And the proper value for  $C_{COMP2}$  is:

$$C_{COMP2} = \frac{C_{OUT} R_{ESR} C_{OUT}}{R_{COMP}} \quad (12)$$

Though  $C_{COMP2}$  is unnecessary when the output capacitor has sufficiently low ESR, a small value  $C_{COMP2}$  such as 100pF may improve stability against PCB layout parasitic effects

**Table 4— Component Selection Guide for Stability Compensation**

Vin Range (V)	Vout (V)	Cout	Rcomp (R3) (k $\Omega$ )	Ccomp (C4) (nF)	Ccomp2 (C5) (pF)	Inductor (uH)
5 – 12	1.0	22uF x2 Ceramic	3.3	5.6	none	4.7
5 - 15	1.2		3.9	4.7	none	4.7
5 - 15	1.8		5.6	3.3	none	10
5 - 15	2.5		8.2	2.2	none	10
5 - 15	3.3		10	2	none	10
5 - 15	5		10	3.3	none	10
5 - 12	1.0	470uF/ 6.3V/ 120m $\Omega$	10	6.8	680	4.7
5 - 15	1.2					10
5 - 23	1.8					
5 - 27	2.5					
5 -27	3.3					
5 -27	5					

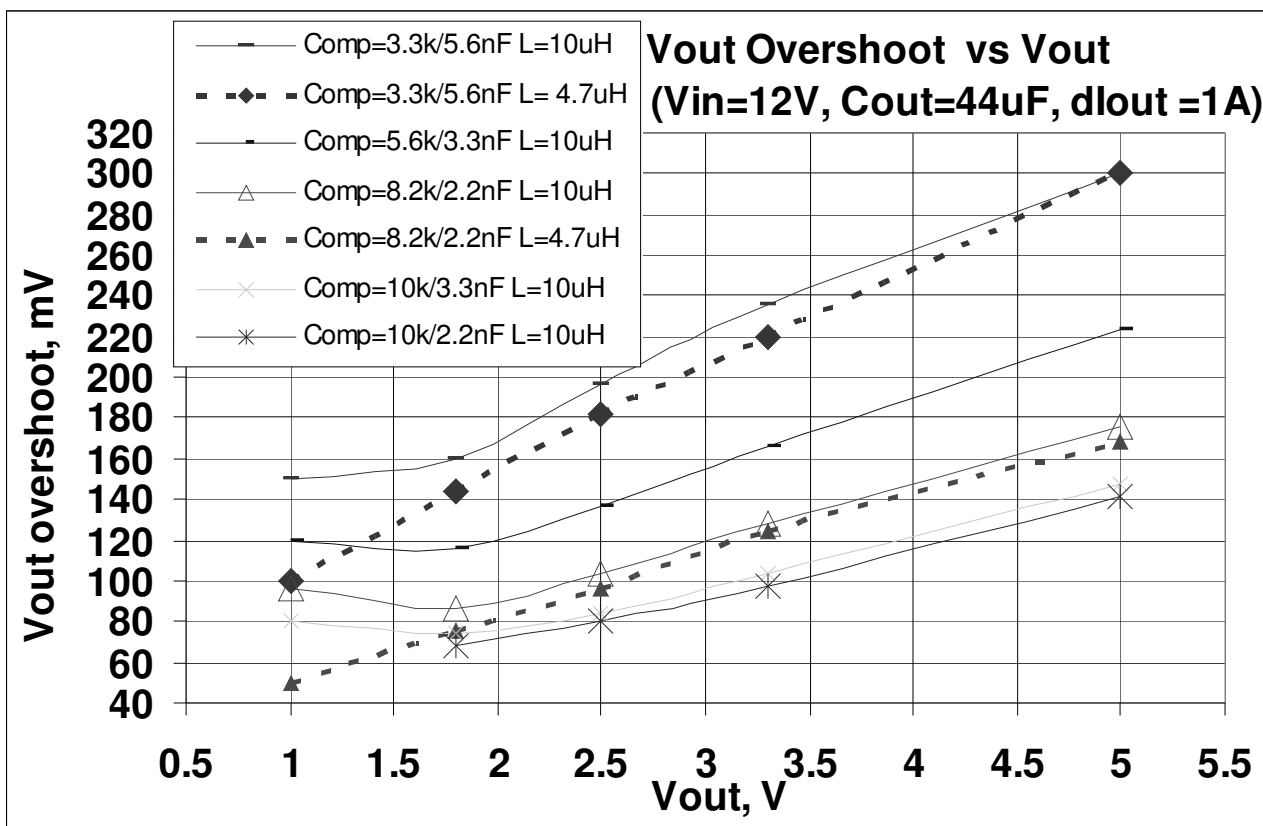

Figure 3. Load Transient Testing vs Compensation Value



### Typical Performance Characteristics

#### Light Load Operation (No load)

Vin=12V, Iin=8.2 mA, Vout=3.3V

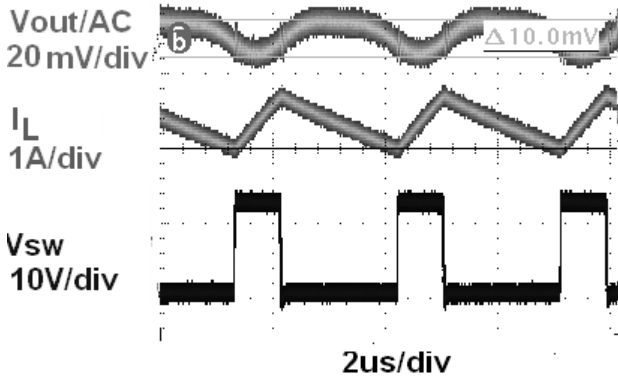

#### Heavy Load Operation (2A Load)

Vin=12V, Vout=3.3V

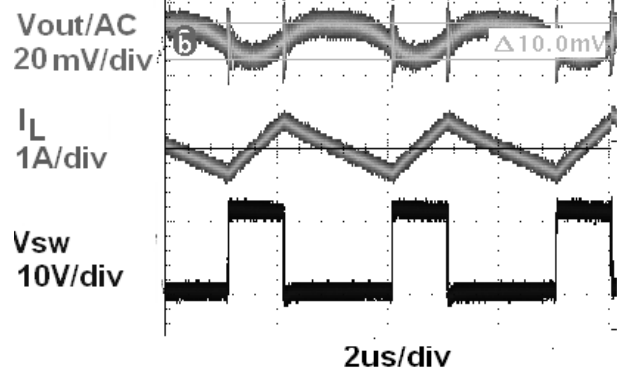

#### Startup Vin=12V, Vout=3.3V, Iout=1A

through Vin.

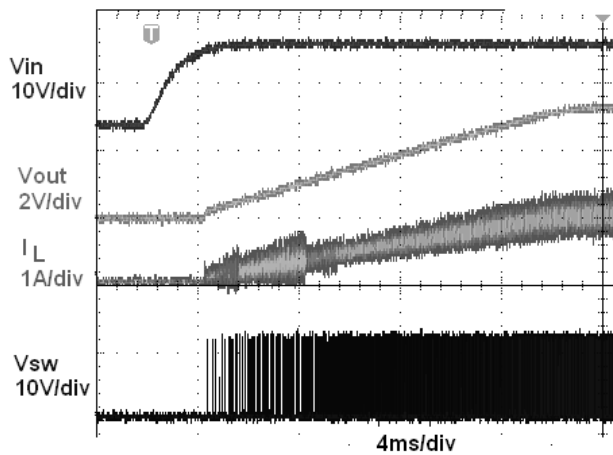

through Enable.

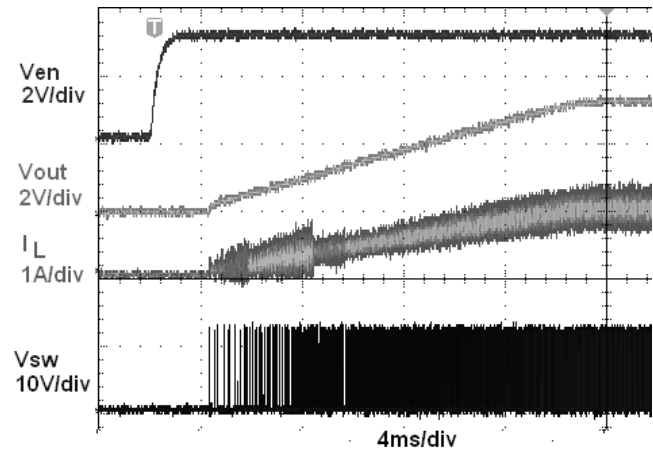

#### Short Circuit Protection Vin=12V

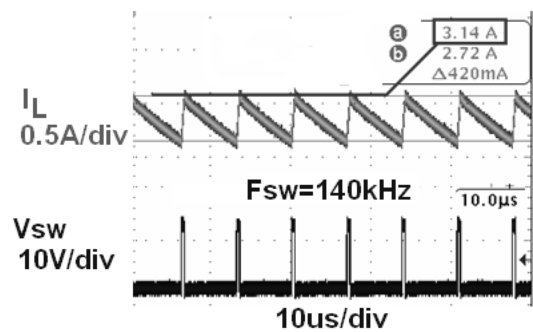
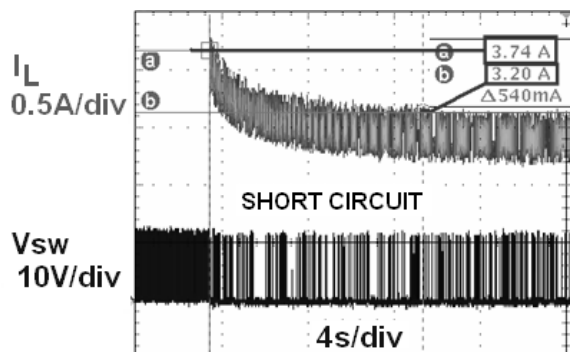

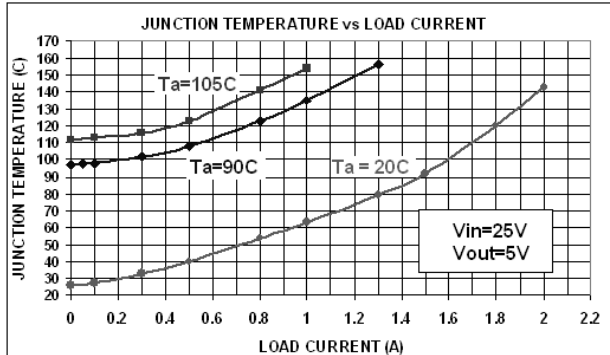
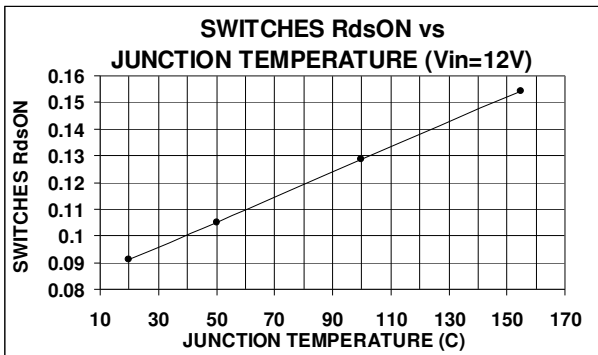
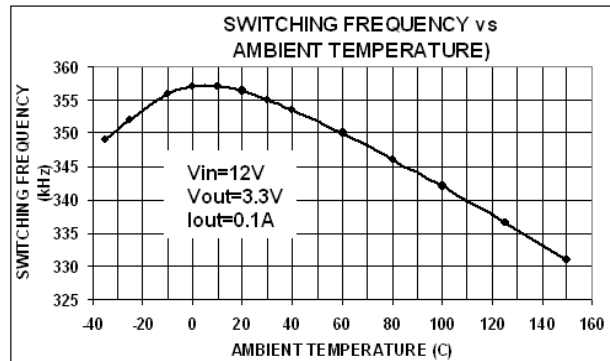
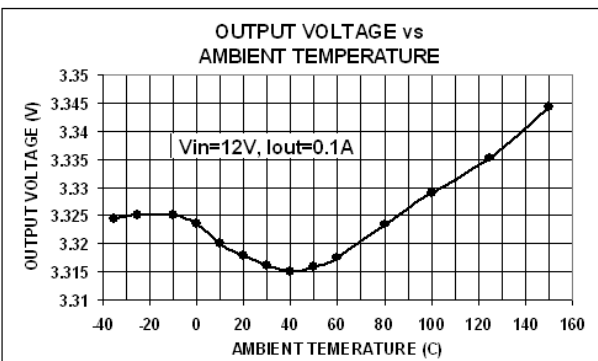
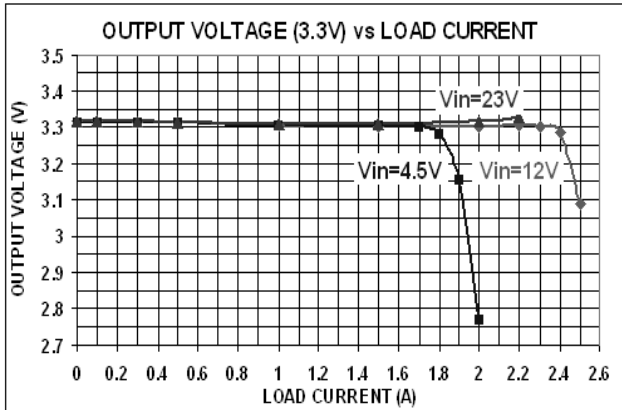
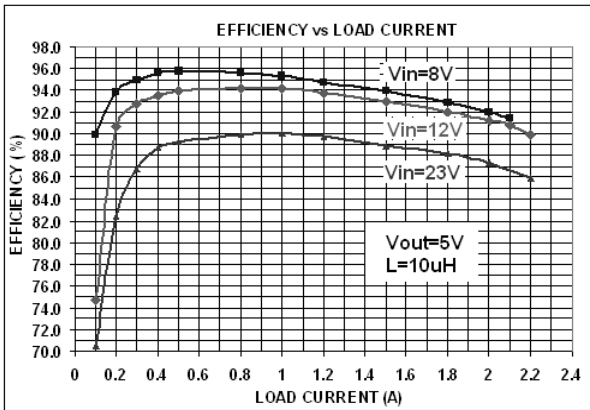



### Marking Information

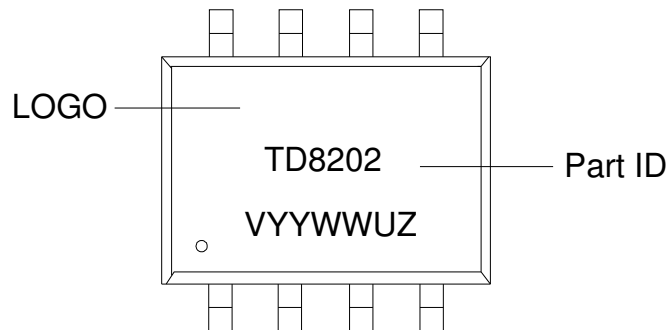

(1)

V YYWW UZ

Internal Code

Date code

YY : Year(09=2009,10=2010,11=2011,12=2012...)

WW : Week(01~53)

Output Voltage

Blank : ADJ

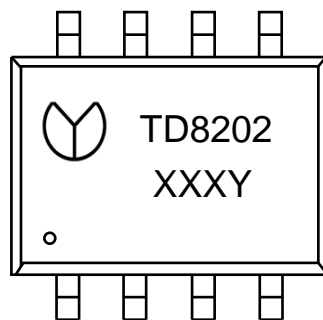

(2)

(1) TD8202: Part number, fixed

(2) XXX: Wafer's Lot No

Y: Internal Code



### Package Information (All Dimensions in mm)

#### SOP-8L

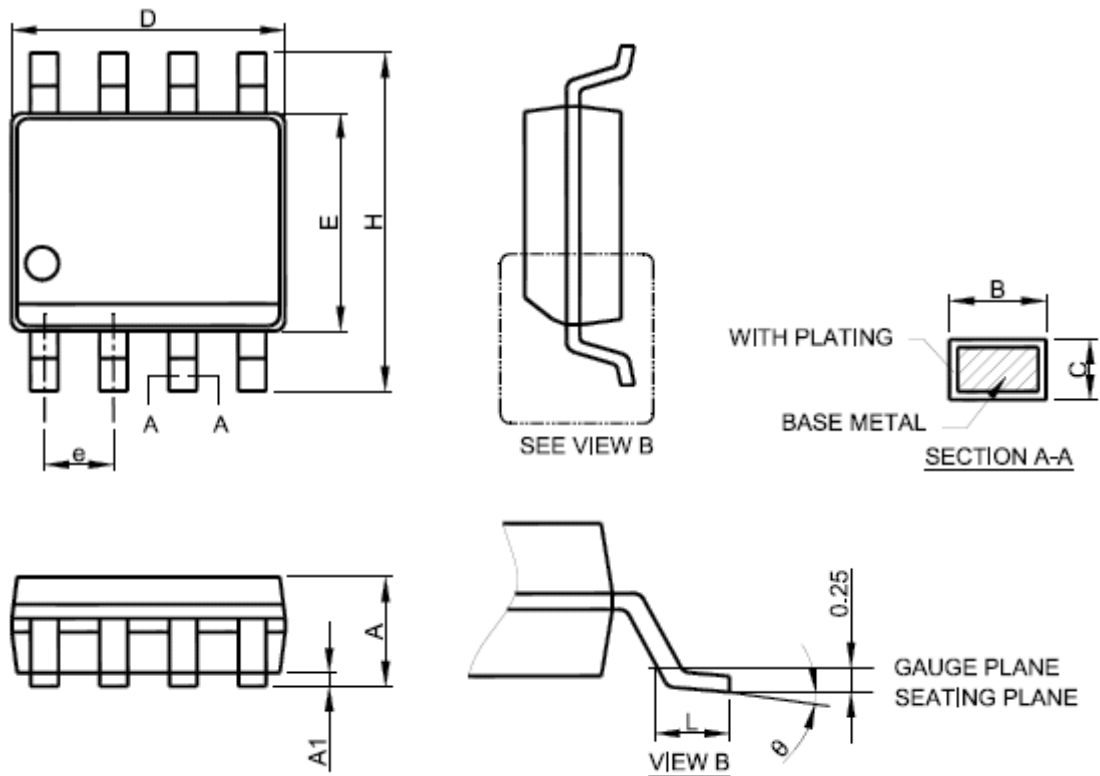

Symbol	Dimensions In Millimeters	
	Min	Max
A	1.35	1.75
A1	0.10	0.25
B	0.33	0.51
C	0.19	0.25
D	4.70	5.10
E	3.70	4.10
E	1.27BSC	
H	5.80	6.20
L	0.40	1.27
$\theta$	0	8°



### Tape/Reel

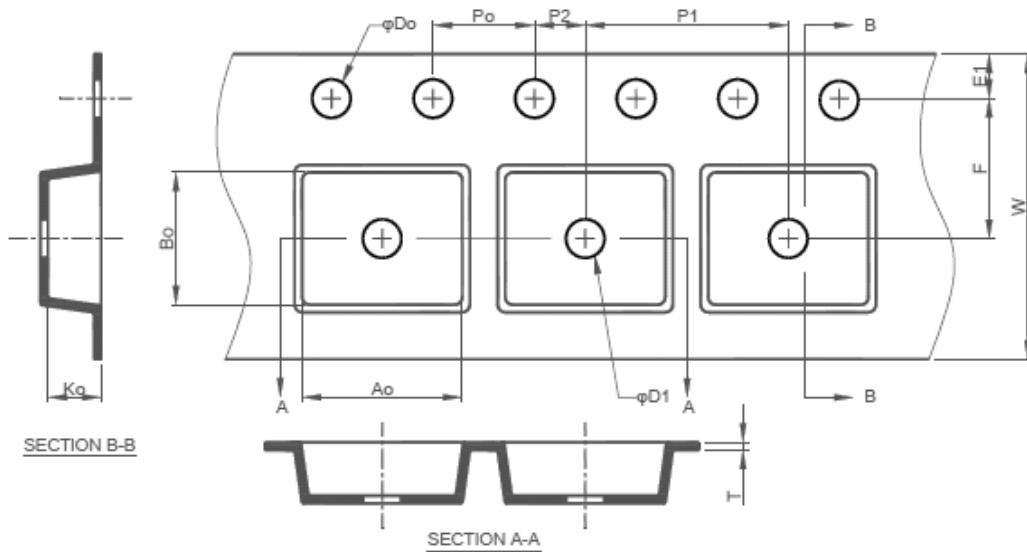

- Note: 1. Refer to EIA-481-B  
 2. 10 sprocket hole pitch cumulative tolerance  $\pm 0.2$   
 3. Material: conductive polystyrene  
 4.  $A_0$  and  $B_0$  measured on a plane 0.3mm above the bottom of the pocket  
 5.  $K_0$  measured from a plane on the inside bottom of the pocket to the top surface of the carrier

SYMBOL	$A_0$	$B_0$	$K_0$	$T$	$D_0$	$D_1$
SPEC	$6.400 \pm 0.100$	$5.350 \pm 0.100$	$2.000 \pm 0.100$	$0.250 \pm 0.020$	$1.550 \pm 0.050$	$1.550 \pm 0.100$
SYMBOL	$P_0$	$P_1$	$P_2$	$E_1$	$F$	$W$
SPEC	$4.000 \pm 0.100$	$8.000 \pm 0.100$	$2.000 \pm 0.050$	$1.750 \pm 0.100$	$5.500 \pm 0.050$	$12.000 \pm 0.30$

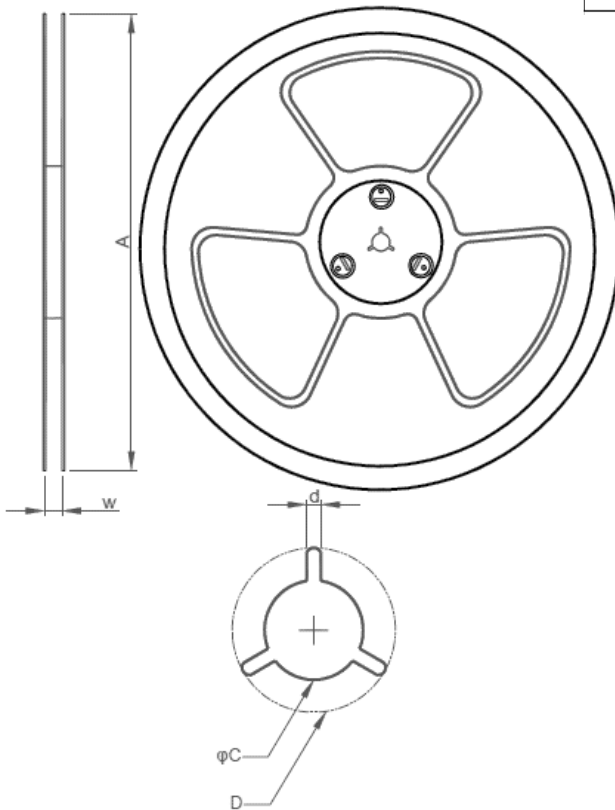

Package Type	A	W	C	d	D
TO-252-3L	$330 \pm 2$	$16.4 \begin{smallmatrix} +2.0 \\ -0.0 \end{smallmatrix}$	$13.0 \begin{smallmatrix} +0.5 \\ -0.2 \end{smallmatrix}$	1.5 MIN.	20.2 MIN.
SOP-8 SOT-223	$330 \pm 2$	$12.4 \begin{smallmatrix} +2.0 \\ -0.0 \end{smallmatrix}$	$13.0 \begin{smallmatrix} +0.5 \\ -0.2 \end{smallmatrix}$	1.5 MIN.	20.2 MIN.
SOT-89-3L	$178 \pm 2$	$12.4 \begin{smallmatrix} +2.0 \\ -0.0 \end{smallmatrix}$	$13.0 \begin{smallmatrix} +0.5 \\ -0.2 \end{smallmatrix}$	1.5 MIN.	20.2 MIN.

Note: Refer to EIA-481-B



### IPC/JEDEC J-STD-020D.1 Moisture Sensitivity Levels Table

LEVEL	FLOOR LIFE		SOAK REQUIREMENTS				
			Standard		Accelerated Equivalent <sup>1</sup>		
					eV 0.40-0.48	eV 0.30-0.39	CONDITION
TIME	CONDITION	TIME (hours)	CONDITION	TIME (hours)	TIME (hours)	CONDITION	
1	Unlimited	≤30 °C /85% RH	168 +5/-0	85 °C /85% RH	NA	NA	NA
2	1 year	≤30 °C /60% RH	168 +5/-0	85 °C /60% RH	NA	NA	NA
2a	4 weeks	≤30 °C /60% RH	696 <sup>2</sup> +5/-0	30 °C /60% RH	120 -1/+0	168 -1/+0	60 °C/ 60% RH
3	168 hours	≤30 °C /60% RH	192 <sup>2</sup> +5/-0	30 °C /60% RH	40 -1/+0	52 -1/+0	60 °C/ 60% RH
4	72 hours	≤30 °C /60% RH	96 <sup>2</sup> +2/-0	30 °C /60% RH	20 +0.5/-0	24 +0.5/-0	60 °C/ 60% RH
5	48 hours	≤30 °C /60% RH	72 <sup>2</sup> +2/-0	30 °C /60% RH	15 +0.5/-0	20 +0.5/-0	60 °C/ 60% RH
5a	24 hours	≤30 °C /60% RH	48 <sup>2</sup> +2/-0	30 °C /60% RH	10 +0.5/-0	13 +0.5/-0	60 °C/ 60% RH
6	Time on Label (TOL)	≤30 °C /60% RH	TOL	30 °C /60% RH	NA	NA	NA

Note 1: CAUTION - To use the “accelerated equivalent” soak conditions, correlation of damage response (including electrical, after soak and reflow), should be established with the “standard” soak conditions. Alternatively, if the known activation energy for moisture diffusion of the package materials is in the range of 0.40 - 0.48 eV or 0.30 - 0.39 eV, the “accelerated equivalent” may be used. Accelerated soak times may vary due to material properties (e.g .mold compound, encapsulant, etc.). JEDEC document JESD22-A120 provides a method for determining the diffusion coefficient.

Note 2: The standard soak time includes a default value of 24 hours for semiconductor manufacturer’s exposure time (MET) between bake and bag and includes the maximum time allowed out of the bag at the distributor’s facility. If the actual MET is less than 24 hours the soak time may be reduced. For soak conditions of 30 °C/60% RH, the soak time is reduced by 1 hour for each hour the MET is less than 24 hours. For soak conditions of 60 °C/60% RH, the soak time is reduced by 1 hour for each 5 hours the MET is less than 24 hours. If the actual MET is greater than 24 hours the soak time must be increased. If soak conditions are 30 °C/60% RH, the soak time is increased 1 hour for each hour that the actual MET exceeds 24 hours. If soak conditions are 60 °C/60% RH, the soak time is increased 1 hour for each 5 hours that the actual MET exceeds 24 hours.



## X-ON Electronics

Largest Supplier of Electrical and Electronic Components

*Click to view similar products for [Isolated DC/DC Converters](#) category:*

*Click to view products by [Shenzhen JingYang](#) manufacturer:*

Other Similar products are found below :

[PSL486-7LR](#) [Q48T30020-NBB0](#) [JAHW100Y1](#) [SPB05C-12](#) [SQ24S15033-PS0S](#) [CE-1003](#) [CE-1004](#) [MAU228](#) [J80-0041NL](#) [DFC15U48D15](#)  
[XGS-1205](#) [06322](#) [SPB05B-15](#) [L-DA20](#) [DCG40-5G](#) [XKS-2405](#) [DPA423R](#) [vi-m13-cw-03](#) [VI-L53-CV](#) [24IBX15-50-0ZG](#) [HZZ01204-G](#)  
[SPU02L-09](#) [SPU02M-09](#) [SPU02N-09](#) [QUINT4-BUFFER/24DC/40](#) [QUINT4-CAP/24DC/5/4KJ](#) [73-551-5039I](#) [DFC15U48D15G](#) [SEN-6471-](#)  
[1EM](#) [AHV2815DF/HBB](#) [MI-LC21-IX](#) [PAH-48/8.5-D48NB1-C](#) [BM3020-7A](#) [QRS2050P025R06](#) [QRS2050P025K00](#) [CM2320-9EG](#)  
[SKMW15F-05](#) [V300A28H400BF3](#) [TEN 15-1223](#) [TEQ 100-2418WIR](#) [TEQ 160-7218WIR](#) [R05C05TE05S-R](#) [HQA2W085W033V-N07-S](#)  
[AM1SS-2405SJZ](#) [AM2DS-1224SJZ](#) [AM2DS-2405DJZ](#) [AM10SBO-4824SNZ-B](#) [AM15E-2405S-NZ](#) [AM2DS-1212SJZ](#) [AM30SBO-](#)  
[4805SNZ-B](#)