

Features

- ❑ Transient protection for high-speed data lines
 - IEC 61000-4-2 (ESD) ±30kV (Air)
 - ±30kV (Contact)
 - IEC 61000-4-4 (EFT) 40A (5/50 ns)
 - Cable Discharge Event (CDE)
- ❑ Package optimized for high-speed lines
- ❑ Ultra-small package (1.0mm × 0.6mm × 0.4mm)
- ❑ Protects one data, control or power line
- ❑ Low capacitance: 15pF (Typical)
- ❑ Low leakage current: 0.1μA @ V_{RWM} (Typical)
- ❑ Low clamping voltage
- ❑ Each I/O pin can withstand over 1000 ESD strikes for ±8kV contact discharge
- ❑ ROHS compliant

Description

TT0501MCX is a low-capacitance Transient Voltage Suppressor (TVS) designed to provide electrostatic discharge (ESD) protection for high-speed data interfaces. With typical capacitance of 15pF only, TT0501MC is designed to protect parasitic-sensitive systems against over-voltage and over-current transient events. It complies with IEC 61000-4-2 (ESD), Level 4 (±15kV air, ±8kV contact discharge), IEC 61000-4-4 (electrical fast transient - EFT) (40A, 5/50 ns), very fast charged device model (CDM) ESD and cable discharge event (CDE), etc.

TT0501MCX uses ultra-small SOD923 package. Each TT0501MCX device can protect one data line. It offers system designers flexibility to protect single data line where space is a premium concern.

Applications

- ❑ Portable Electronics
- ❑ Desktops, Servers and Notebooks
- ❑ Cellular Phones
- ❑ MP3 Ports
- ❑ Digital Camera Ports

Mechanical Characteristics

- ❑ SOD-923 package
- ❑ Flammability Rating: UL 94V-0
- ❑ Marking: Part number
- ❑ Packaging: Tape and Reel

Circuit Diagram



Pin Configuration

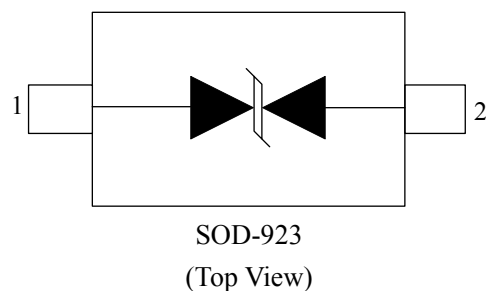

Absolute Maximum Rating

Symbol	Parameter	Value	Units
V_{ESD}	ESD per IEC 61000-4-2 (Air)	±30	kV
	ESD per IEC 61000-4-2 (Contact)	±30	
T_{OPT}	Operating Temperature	-55/+125	°C
T_{STG}	Storage Temperature	-55/+150	°C

Electrical Characteristics (T = 25°C)

Symbol	Parameter
V_{RWM}	Nominal Reverse Working Voltage
I_R	Reverse Leakage Current @ V_{RWM}
V_{BR}	Reverse Breakdown Voltage @ I_T
I_T	Test Current for Reverse Breakdown
V_C	Clamping Voltage @ I_{PP}
I_{PP}	Maximum Peak Pulse Current
C_{ESD}	Parasitic Capacitance
V_R	Reverse Voltage
f	Small Signal Frequency

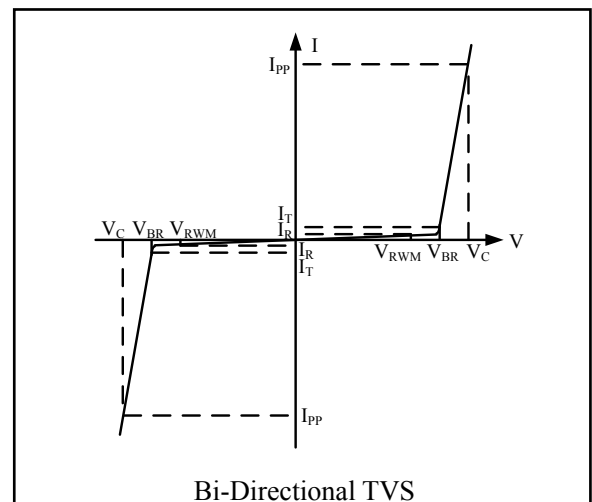

Symbol	Test Condition	Minimum	Typical	Maximum	Units
V_{RWM}				5.0	V
I_R	$V_{RWM} = 5V, T = 25^\circ C$ Between I/O_1 and I/O_2		0.1	1.0	μA
V_{BR}	$I_T = 1mA$ Between I/O_1 and I/O_2	5.5	6.0	8.0	V
V_C	$I_{PP} = 1A, t_p = 8/20\mu s$ Between I/O_1 and I/O_2			10	V
V_C	$I_{PP} = 4A, t_p = 8/20\mu s$ Between I/O_1 and I/O_2			15	V
C_{ESD}	$V_R = 0V, f = 1MHz$ Between I/O_1 and I/O_2		15	17	pF

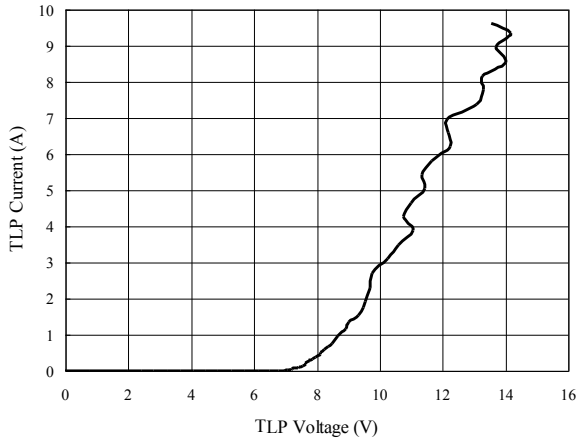
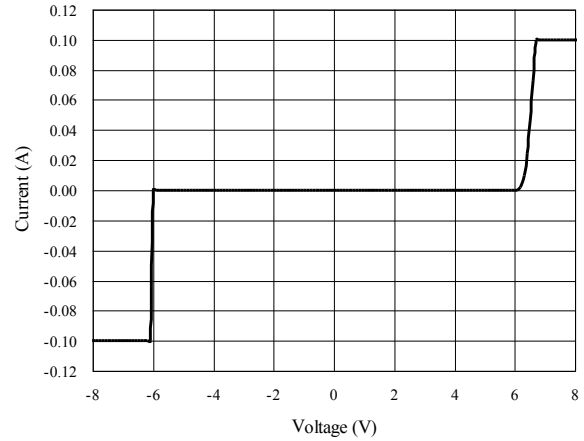
TLP Measurement of I/O_1 to I/O_2

Voltage Sweeping of I/O_1 to I/O_2

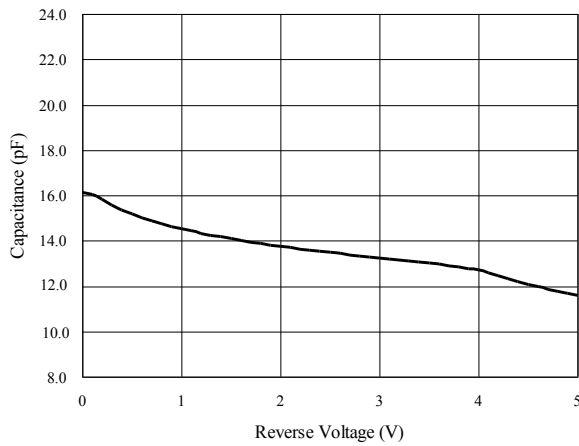
Capacitance vs. Voltage of I/O_1 to I/O_2 (f = 1MHz)

Capacitance vs. Reverse Voltage

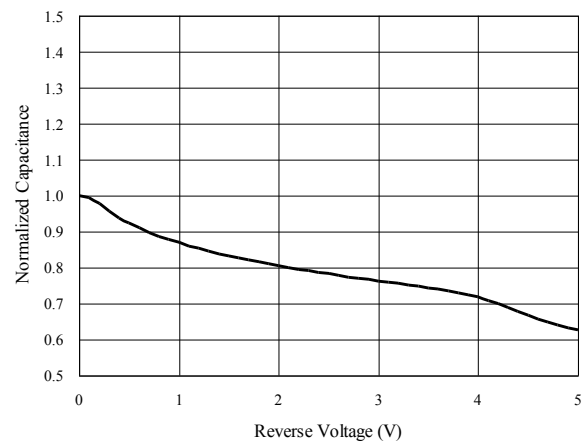
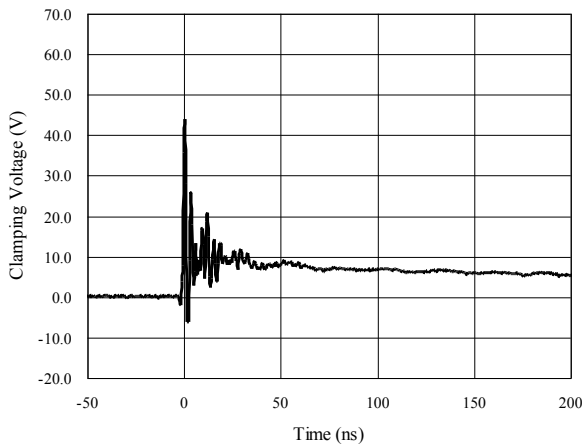
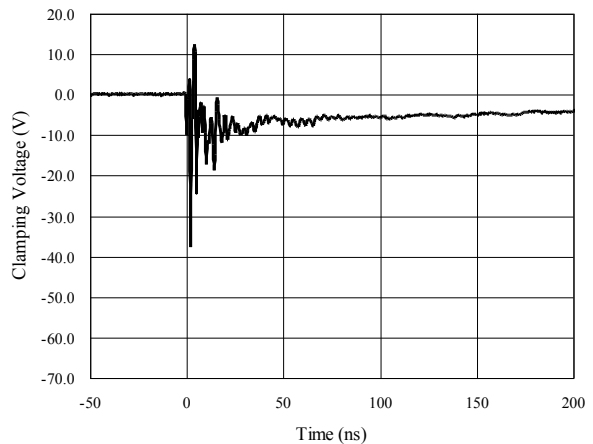

Normalized Capacitance vs. Reverse Voltage

**ESD Clamping of I/O_1 to I/O_2
(+8kV Contact per IEC 61000-4-2)**

**ESD Clamping of I/O_1 to I/O_2
(-8kV Contact per IEC 61000-4-2)**

Package Outline

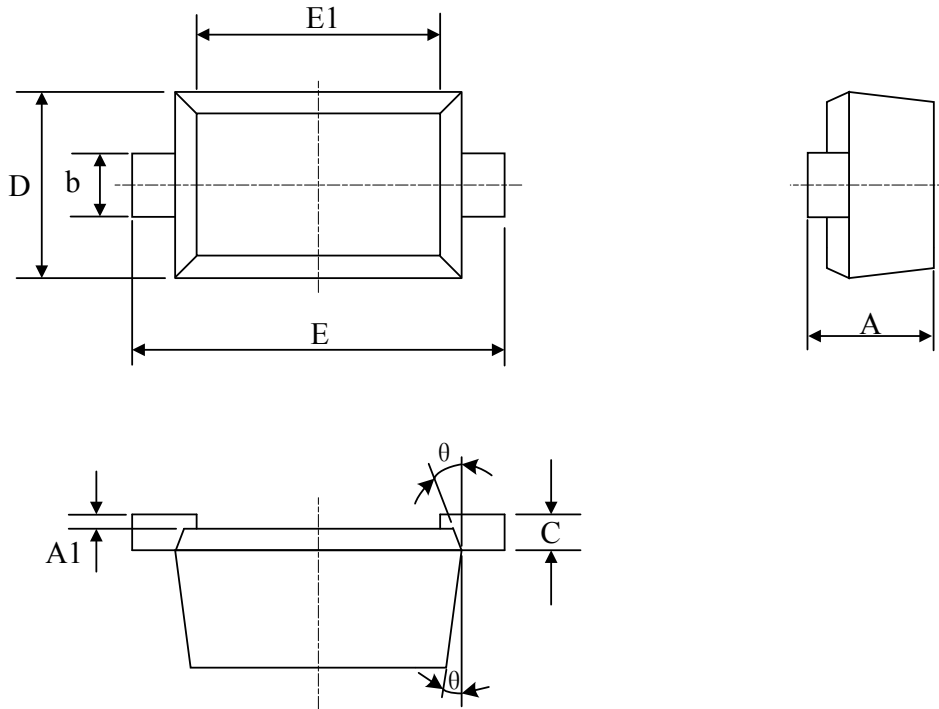
- ❑ SOD-923 package
- ❑ 2 leads, very small package
- ❑ MSL-1



Package Dimensions (Controlling dimensions are in millimeters)

Symbol	Dimensions (mm)		Dimensions (Inches)	
	Minimum	Maximum	Minimum	Maximum
A	0.350	0.430	0.014	0.017
A1	0.000	0.050	0.000	0.002
b	0.170	0.270	0.007	0.011
C		0.150		0.006
D	0.550	0.650	0.022	0.026
E	0.900	1.100	0.035	0.043
E1	0.750	0.850	0.030	0.033
θ	7° REF.		7° REF.	

Tape and Reel Specification

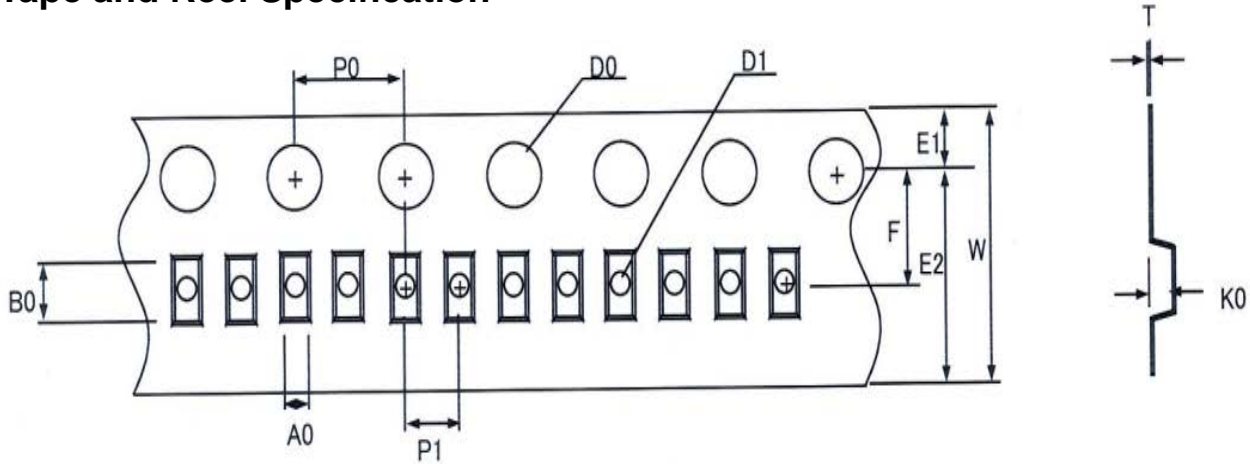

ITEM	Dimensions (mm)
A0	0.67 +/- 0.05
B0	1.12 +/- 0.05
W	8.0 +/- 0.2
D0	1.55 +/- 0.05
D1	0.50 +/- 0.05
E1	1.75 +/- 0.10
E2	6.25 MIN
F	3.50 +/- 0.10
P0	4.0 +/- 0.05
P1	2.0 +/- 0.05
K0	0.52 +/- 0.05 *1
T	0.20 +/- 0.020

Marking Codes

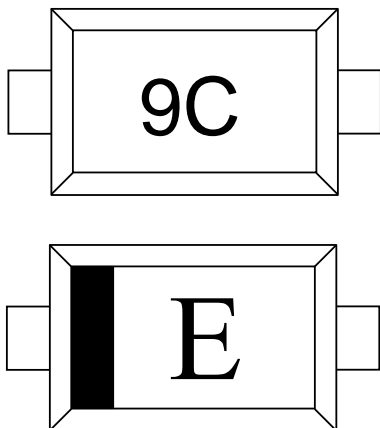

Ordering Information

Part Number	Working Voltage	Quantity Per Reel	Reel Size
TT0501MCX	5V	8,000	7 Inch

Note:

(1) "9C/E" is part number, fixed.

X-ON Electronics

Largest Supplier of Electrical and Electronic Components

Click to view similar products for [ESD Suppressors / TVS Diodes](#) category:

Click to view products by [Shenzhen JingYang](#) manufacturer:

Other Similar products are found below :

[60KS200C](#) [D18V0L1B2LP-7B](#) [D5V0F4U5P5-7](#) [NTE4902](#) [P4KE27CA](#) [P6KE11CA](#) [P6KE8.2A](#) [SA60CA](#) [SA64CA](#) [SMBJ12CATR](#)
[SMBJ33CATR](#) [SMBJ6.5A](#) [SMBJ8.0A](#) [ESD101-B1-02ELS](#) [E6327](#) [ESD112-B1-02EL](#) [E6327](#) [ESD7451N2T5G](#) [19180-510](#) [CPDT-5V0USP-](#)
[HF](#) [3.0SMCJ33CA-F](#) [3.0SMCJ36A-F](#) [HSPC16701B02TP](#) [JANTX1N6126A](#) [D3V3Q1B2DLP3-7](#) [D55V0M1B2WS-7](#) [SCM1293A-04SO](#)
[ESD200-B1-CSP0201](#) [E6327](#) [SM12-7](#) [CEN955](#) [W/DATA](#) [VESD12A1A-HD1-GS08](#) [CPDQC5V0-HF](#) [D1213A-01LP4-7B](#) [ESD101-B1-02EL](#)
[E6327](#) [AOZ8808DI-03](#) [5KP15A](#) [5KP48A](#) [5KP90A](#) [ESD3V3D7-TP](#) [15KPA36A-LF](#) [P4KE56CA](#) [P4KE68A](#) [P4KE91CATR](#) [P6KE120A](#)
[P6KE13CA](#) [P6KE43CA](#) [P6KE6.8CA](#) [P6KE8.2](#) [P6SMBJ20CA](#) [JANTX1N6072A](#) [SR2835ESKG](#) [SA90CA](#)