

Features

- ❑ Transient protection for high-speed data lines
 - IEC 61000-4-2 (ESD) ±27kV (Air)
 - ±17kV (Contact)
 - IEC 61000-4-4 (EFT) 40A (5/50 ns)
 - Cable Discharge Event (CDE)
- ❑ Small package (2.9mm × 2.8mm × 1.4mm)
- ❑ Protects four data lines
- ❑ Low capacitance: 0.3pF Typical (I/O-I/O)
- ❑ Low leakage current: 0.1μA @ V_{RWM} (Typical)
- ❑ Low clamping voltage
- ❑ Each I/O pin can withstand over 1000 ESD strikes for ±8kV contact discharge
- ❑ Green Part

Description

TT0554TLX is an ultra-low capacitance Transient Voltage Suppressor (TVS) designed to provide electrostatic discharge (ESD) protection for high-speed data interfaces. With typical capacitance of 0.3pF only, TT0554TLX is designed to protect parasitic-sensitive systems against over-voltage and over-current transient events. It complies with IEC 61000-4-2 (ESD), Level 4 (±15kV air, ±8kV contact discharge), IEC 61000-4-4 (electrical fast transient - EFT) (40A, 5/50 ns), very fast charged device model (CDM) ESD and cable discharge event (CDE), etc.

TT0554TLX uses small SOT23-6L package. Each TT0554TLX device can protect four high-speed data lines. The combined features of low capacitance, small size and high ESD robustness make TT0554TLX ideal for high-speed data ports and high-frequency lines (e.g., HDMI & DVI) applications. The low clamping voltage of the TT0554 TLX guarantees a minimum stress on the protected IC.

Applications

- ❑ Serial ATA
- ❑ PCI Express
- ❑ Desktops, Servers and Notebooks
- ❑ MDDI Ports
- ❑ USB 2.0/3.0 Power and Data Line Protection
- ❑ Display Ports
- ❑ High Definition Multi-Media Interface (HDMI)
- ❑ Digital Visual Interfaces (DVI)

Mechanical Characteristics

- ❑ SOT23-6L package
- ❑ Flammability Rating: UL 94V-0
- ❑ Marking: Part number
- ❑ Packaging: Tape and Reel

Circuit Diagram

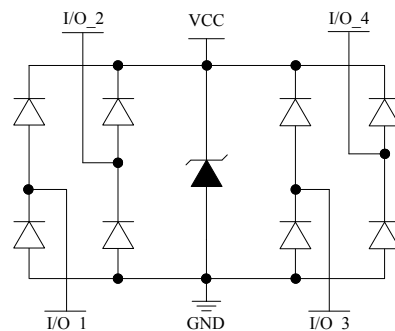

Pin Configuration

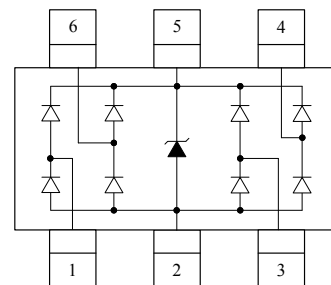

SOT23-6L
(Top View)

Absolute Maximum Rating

Symbol	Parameter	Value	Units
P_{PP}	Peak Pulse Power (8/20 μ s) (I/O pins)	60	W
I_{PP}	Peak Pulse Current($t_p=8/20\mu s$) (I/O pins)	6	A
V_{ESD}	ESD per IEC 61000-4-2(Air) ESD per IEC 61000-4-2 (Contact)	± 25 ± 17	kV
T_{OPT}	Operating Temperature	-55/+125	$^{\circ}C$
T_{STG}	Storage Temperature	-55/+150	$^{\circ}C$

Electrical Characteristics (T = 25 $^{\circ}C$)

Symbol	Parameter
V_{RWM}	Nominal Reverse Working Voltage
I_R	Reverse Leakage Current @ V_{RWM}
V_{BR}	Reverse Breakdown Voltage @ I_T
I_T	Test Current for Reverse Breakdown
V_C	Clamping Voltage @ I_{PP}
I_{PP}	Maximum Peak Pulse Current
C_{ESD}	Parasitic Capacitance
V_R	Reverse Voltage
f	Small Signal Frequency
I_F	Forward Current
V_F	Forward Voltage @ I_F

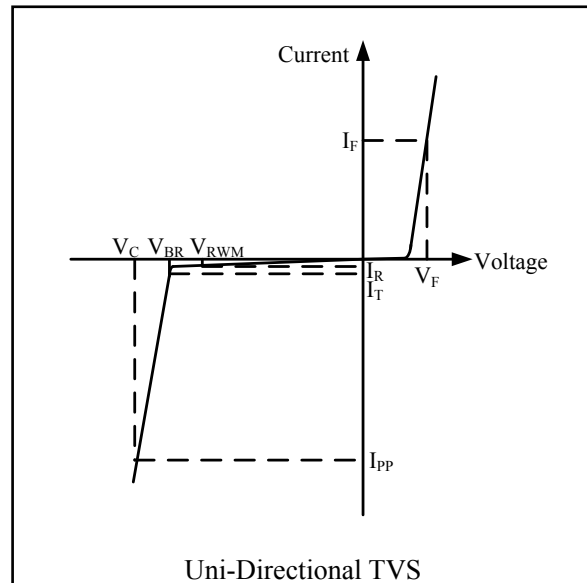

Symbol	Test Condition	Minimum	Typical	Maximum	Units
V_{RWM}				5.0	V
I_R	$V_{RWM} = 5V, T = 25^{\circ}C$ Between I/O and GND , Between VCC and GND		0.1	1.0	μA
V_{BR}	$I_T = 1mA$ Between I/O and GND , Between VCC and GND	6.0		9.0	V
V_C	$I_{PP} = 6A, t_p = 8/20\mu s$ Between I/O and GND			11.0	V
C_{ESD}	$V_R = 0V, f = 1MHz$ Between I/O and GND		0.6	0.8	pF
C_{ESD}	$V_R = 0V, f = 1MHz$ Between I/O and I/O		0.3	0.4	pF

TLP Measurement of I/O to GND

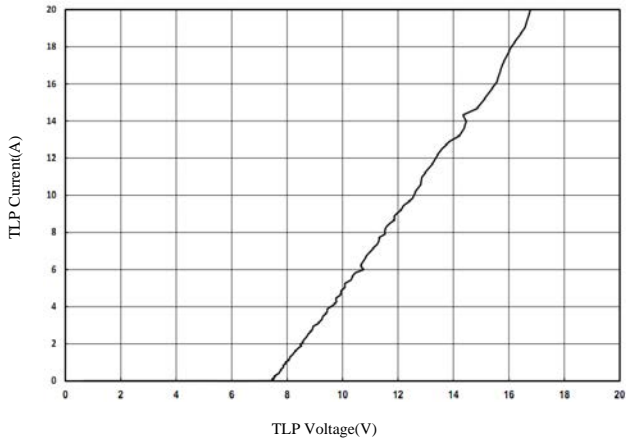

Insertion Loss S21 of I/O to GND

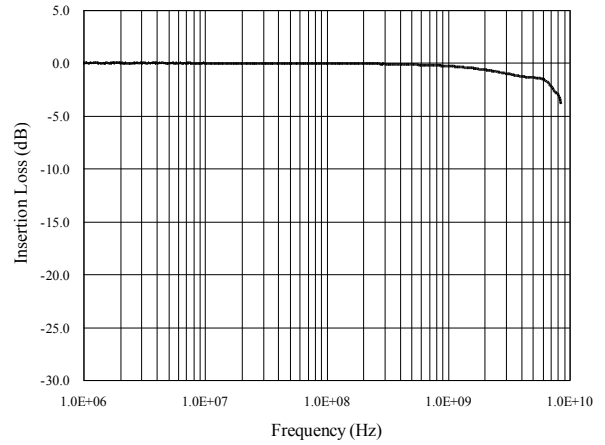

Capacitance vs. Voltage of I/O to GND (f = 1MHz)

Capacitance vs. Reverse Voltage

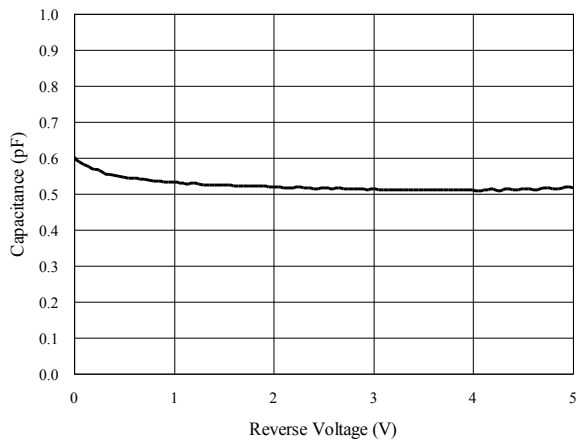

Normalized Capacitance vs. Reverse Voltage

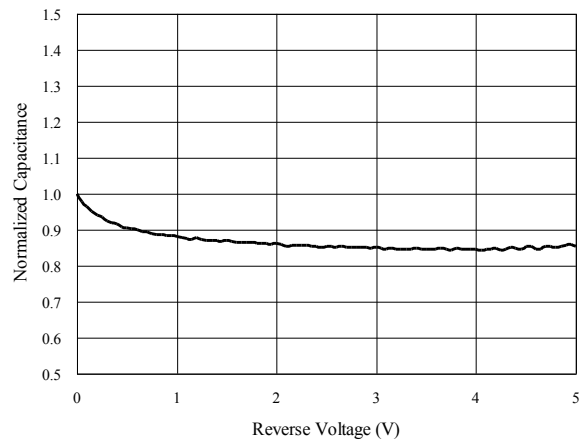

ESD Clamping of I/O to GND (+8kV Contact per IEC 61000-4-2)

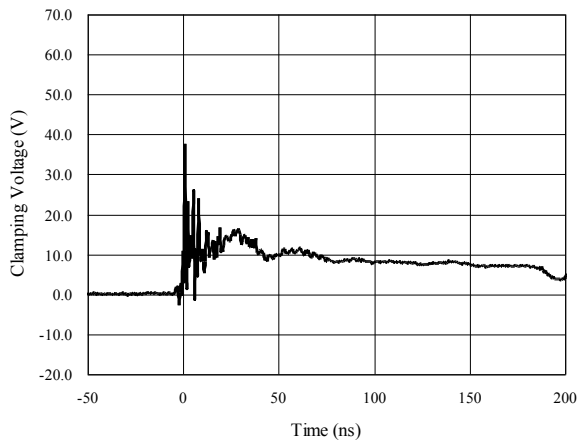

ESD Clamping of I/O to GND (-8kV Contact per IEC 61000-4-2)

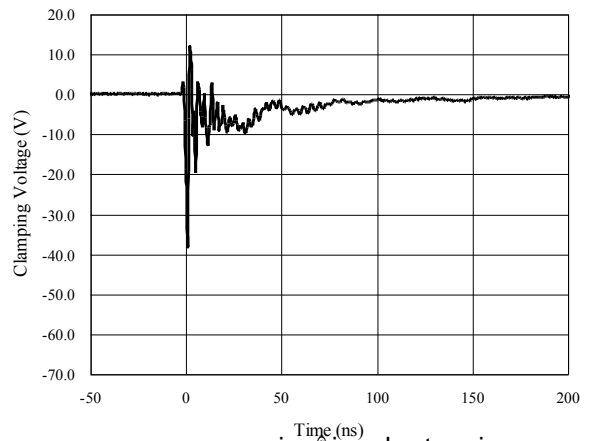

Application Information

Pin Connection in PCB

TT0554TLX is capable to provide ESD protection for four data lines simultaneously. The pin connection is shown in Figure 1.

Four parallel data lines, from inner IC to I/O port connector, could connect to TT0554TLX four I/O pins directly. Pin 2 of TT 0554 TLX is the negative reference pin, which should connect to the GND of PCB. The connection wires should be as short as possible in order to minimize the parasitic inductance.

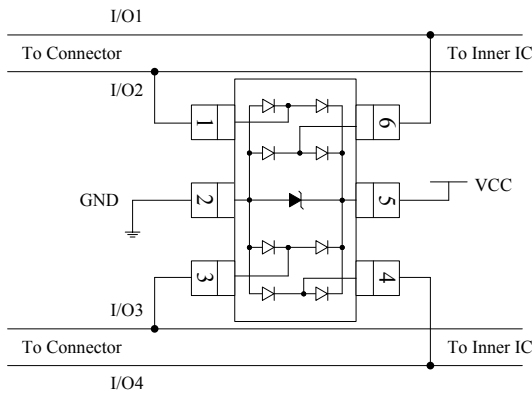

Figure 1 TT0554TLX pin connection in PCB

PCB Layout Guidelines

For optimum ESD protection and the whole circuit performance, the following PCB layout guidelines are recommended:

- ❑ TT0554 TLX GND pin to the PCB GND rail path should be as short as possible. It could reduce the ESD transient return path to GND.
- ❑ The vias connecting TT0554TLX VCC & GND pins to the PCB VCC & GND should be wide.
- ❑ Place TT0554TLX as close to the connector port as possible. It could reduce the parasitic inductance and restrict ESD coupling into adjacent traces.
- ❑ Avoid running critical signals near board edges.

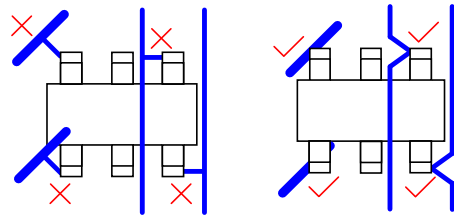
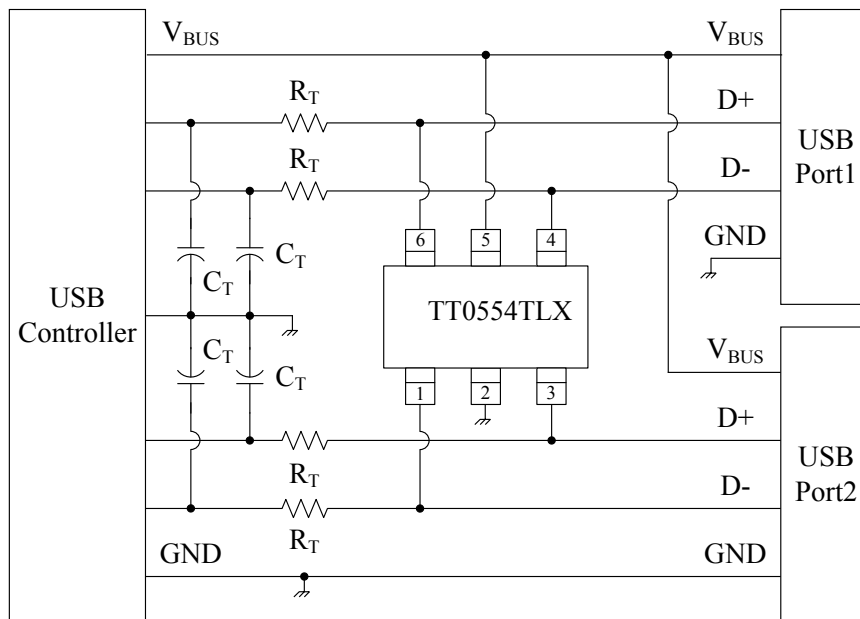

Figure 2 TT0554TLX Layout Guideline

Universal Serial Bus ESD Protection



service@jy-electronics.com.cn

Application Information (continued)

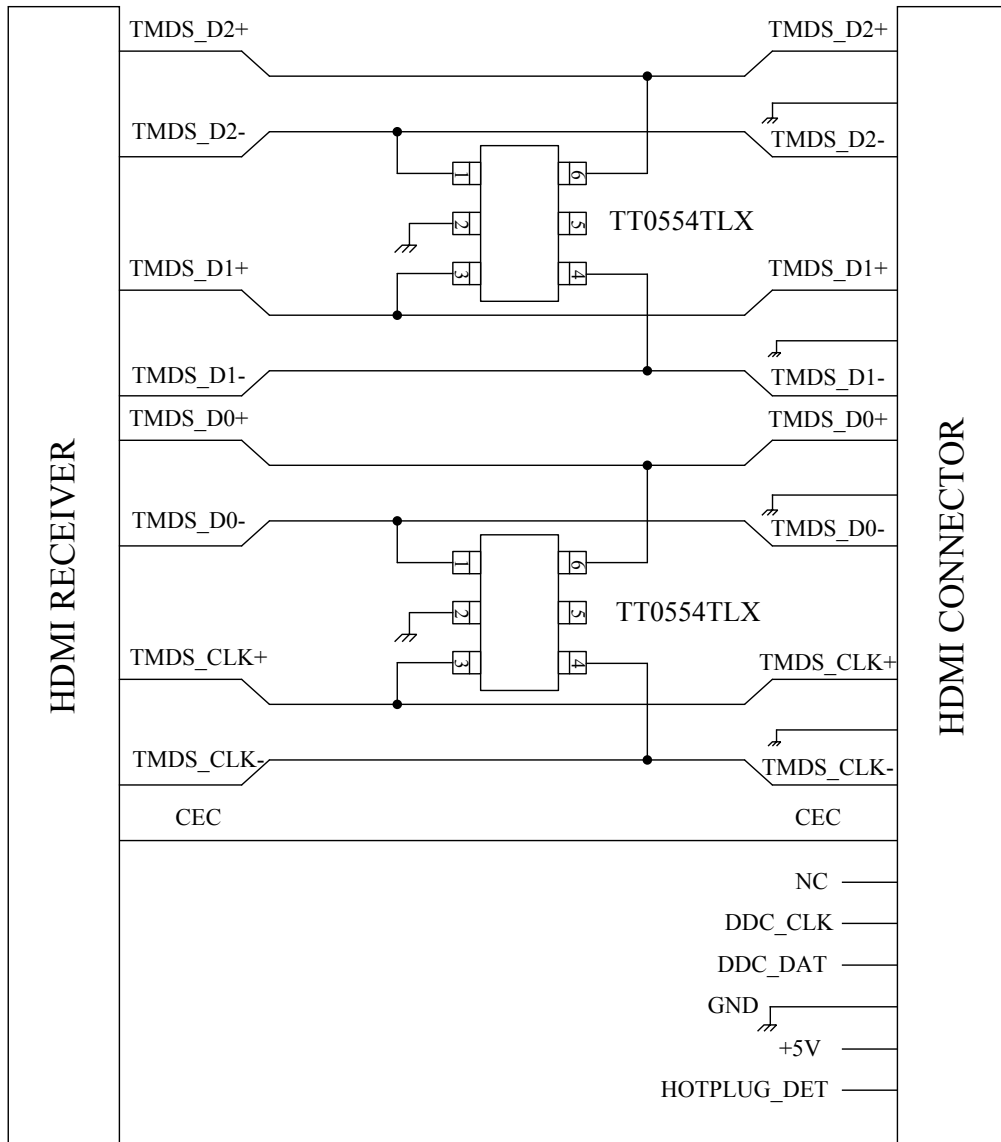

Layout Top View for HDMI Interface with TT0554TLX



Package Outline

□ SOT23-6L package

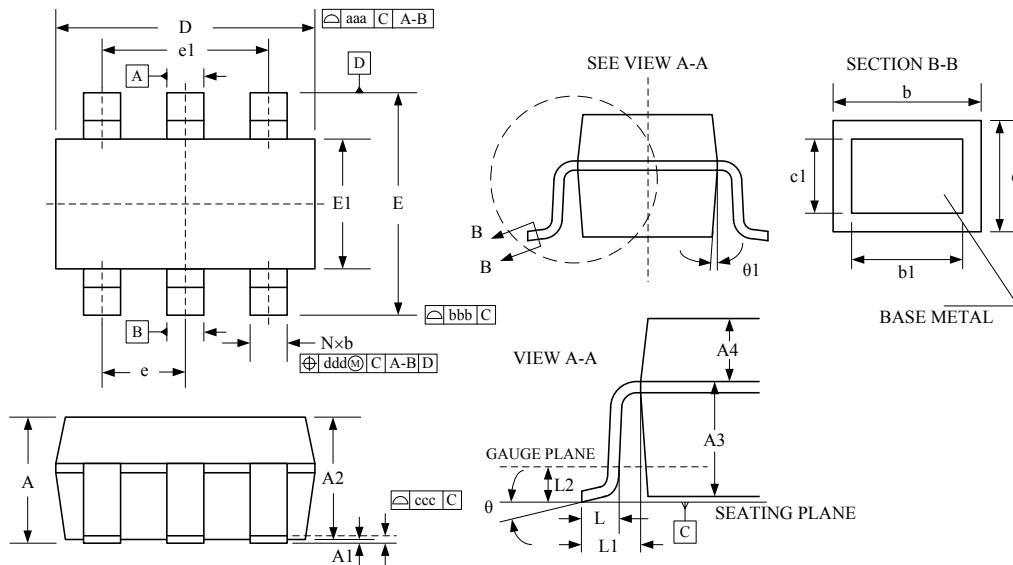

Package Dimensions (Controlling dimensions are in millimeters)

Symbol	Dimensions (mm)			Dimensions (Inches)		
	Minimum	Typical	Maximum	Minimum	Typical	Maximum
A	—	—	1.450	—	—	0.057
A1	0.000	—	0.150	0.000	—	0.006
A2	0.900	1.200	1.300	0.035	0.047	0.012
A3	0.637	0.787	0.837	0.025	0.031	0.033
A4	0.263	0.413	0.463	0.010	0.016	0.018
b	0.300	—	0.500	0.012	—	0.020
b1	0.300	0.400	0.450	0.012	0.016	0.018
c	0.080	—	0.220	0.003	—	0.009
c1	0.080	0.130	0.200	0.003	0.005	0.008
D	2.90 BSC			0.114 BSC		
e	0.95 BSC			0.037 BSC		
e1	1.90 BSC			0.075 BSC		
E	2.80 BSC			0.110 BSC		
E1	1.60 BSC			0.063 BSC		
L	0.300	0.450	0.600	0.012	0.018	0.024
L1	0.600 REF			0.024 REF		
L2	0.250 BSC			0.010 BSC		
θ	0°	4°	8°	0°	4°	8°
θ1	5°	10°	15°	5°	10°	15°
aaa	0.150			0.006		
bbb	0.200			0.008		
ccc	0.100			0.004		
ddd	0.100			0.004		

Tape and Reel Specification

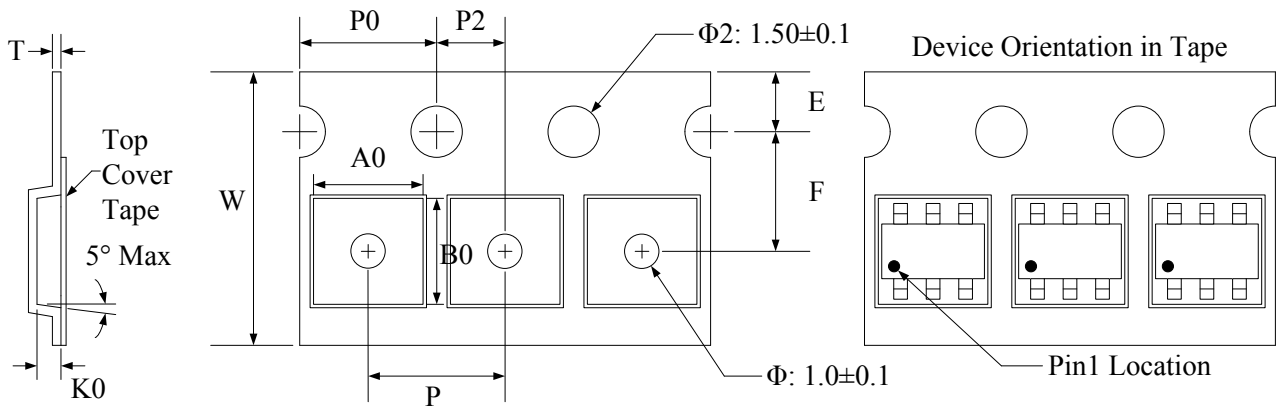

Symbol	W	A0	B0	K0	E	F	P	P0	P2	T
Dimensions (mm)	8.00+0.3 -0.1	3.23±0.05	3.17±0.05	1.37±0.05	1.75±0.1	3.5±0.05	4.0±0.1	4.0±0.1	2.0±0.05	0.25±0.02

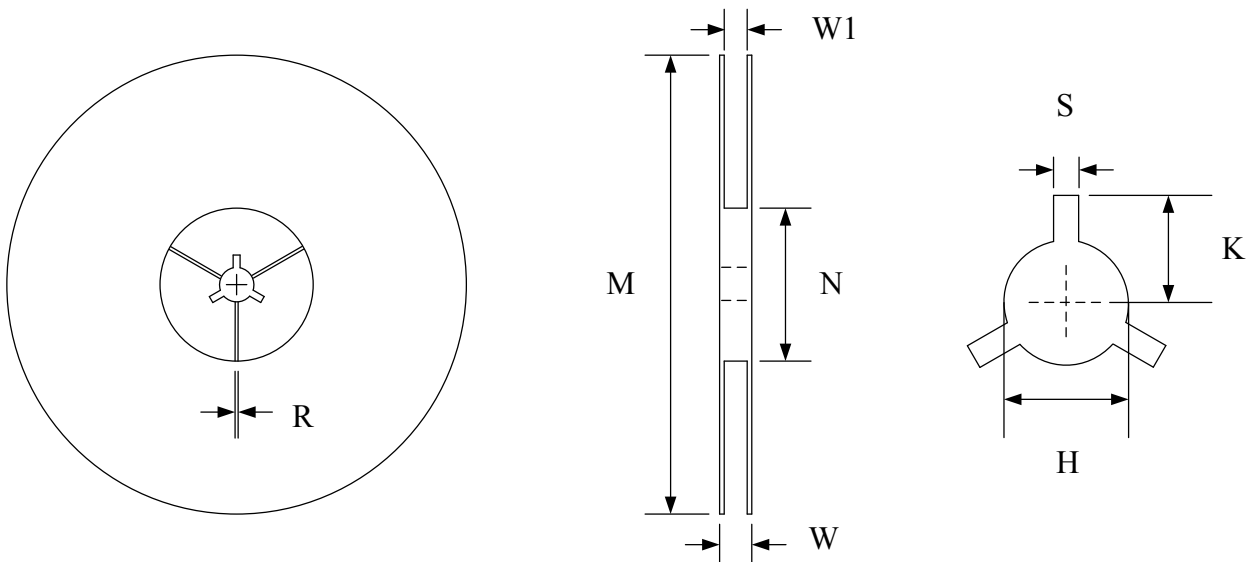

Symbol	Reel Size	M	N	W	W1	H	S	K	R
Dimensions (mm)	$\Phi 178$	178.0±1.0	60.0±1.0	11.5±0.5	9.0±0.5	13.0±0.5	2.0±0.1	11.0±0.2	1.0±0.05

Marking Codes

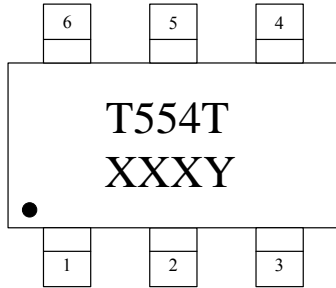

Note:

- (1) "T554T" is the part number, fixed.
- (2) "XXX" is the last 3 characters of the wafer's Lot No.,
 "Y" is the internal code.

Ordering Information

Part Number	Working Voltage	Quantity Per Reel	Reel Size
TT0554TLX	5V	3,000	7 Inch

Footprint: SOT23-6L

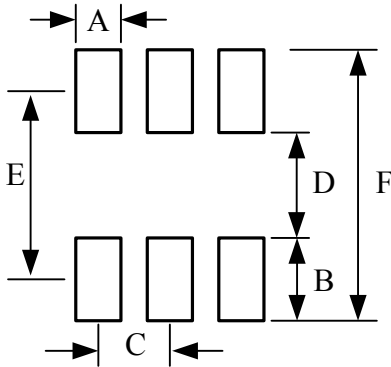

Symbol	Dimensions	
	Millimeters	Inches
A	0.60	0.024
B	1.10	0.043
C	0.95	0.037
D	1.40	0.055
E	2.50	0.098
F	3.60	0.141

X-ON Electronics

Largest Supplier of Electrical and Electronic Components

Click to view similar products for [ESD Suppressors / TVS Diodes](#) category:

Click to view products by [Shenzhen JingYang](#) manufacturer:

Other Similar products are found below :

[60KS200C](#) [D18V0L1B2LP-7B](#) [D5V0F4U5P5-7](#) [NTE4902](#) [P4KE27CA](#) [P6KE11CA](#) [P6KE8.2A](#) [SA60CA](#) [SA64CA](#) [SMBJ12CATR](#)
[SMBJ33CATR](#) [SMBJ6.5A](#) [SMBJ8.0A](#) [ESD101-B1-02ELS](#) [E6327](#) [ESD112-B1-02EL](#) [E6327](#) [ESD7451N2T5G](#) [19180-510](#) [CPDT-5V0USP-](#)
[HF](#) [3.0SMCJ33CA-F](#) [3.0SMCJ36A-F](#) [HSPC16701B02TP](#) [JANTX1N6126A](#) [D3V3Q1B2DLP3-7](#) [D55V0M1B2WS-7](#) [SCM1293A-04SO](#)
[ESD200-B1-CSP0201](#) [E6327](#) [SM12-7](#) [CEN955](#) [W/DATA](#) [VESD12A1A-HD1-GS08](#) [CPDQC5V0-HF](#) [D1213A-01LP4-7B](#) [ESD101-B1-02EL](#)
[E6327](#) [AOZ8808DI-03](#) [5KP15A](#) [5KP48A](#) [5KP90A](#) [ESD3V3D7-TP](#) [15KPA36A-LF](#) [P4KE56CA](#) [P4KE68A](#) [P4KE91CATR](#) [P6KE120A](#)
[P6KE13CA](#) [P6KE43CA](#) [P6KE6.8CA](#) [P6KE8.2](#) [P6SMBJ20CA](#) [JANTX1N6072A](#) [SR2835ESKG](#) [SA90CA](#)