

NPN-Silicon General use Transistors

1W 、 1.5A、 25V

Applications: Can be used for switching and amplifying in various electrical and electronic circuit.

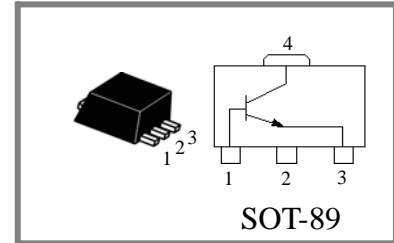

1 Base 2/4 Collector 3 Emitter

Maximum ratings

Parameters	Symbol	Rating	Unit
Collector-emitter voltage ($I_B=0$)	V_{CEO}	25	V
Collector-base voltage ($I_E=0$)	V_{CBO}	40	V
Emitter-base voltage ($I_C=0$)	V_{EBO}	6	V
Collector current	I_C	1.5	A
Total dissipation power($T_A=25^\circ\text{C}$)*	P_{tot}	1	W
Junction temperature	T_{jm}	150	$^\circ\text{C}$
Storage temperature	T_{stg}	-55~150	$^\circ\text{C}$

* Device is mounted on a printed circuit board.

Electrical characteristics (Unless otherwise specified, $T_A=25^\circ\text{C}$)

Parameters		Symbol	Test condition	Min.	typ	Max.	Unit
Collector-emitter breakdown voltage		$V_{(BR)CEO}$	$I_C=2\text{mA}$, $I_B=0$	25	—	—	V
Collector-base breakdown voltage		$V_{(BR)CBO}$	$I_C=100\mu\text{A}$, $I_E=0$	40	—	—	V
Emitter-base breakdown voltage		$V_{(BR)EBO}$	$I_E=100\mu\text{A}$, $I_C=0$	6	—	—	V
Forward current transfer ratio	X M	h_{FE}	$V_{CE}=1\text{V}$; $I_C=100\text{mA}$	135	—	270	—
	X L			200	—	400	—
Collector-base current		I_{CBO}	$V_{CB}=35\text{V}$, $I_E=0$	—	—	100	nA
Collector-emitter saturation voltage		$V_{CE(sat)}$	$I_C=800\text{mA}$, $I_B=80\text{mA}$	—	—	0.5	V
Characteristic frequency		f_T	$I_C=50\text{mA}$, $V_{CE}=10\text{V}$, $f=100\text{MHz}$	—	100	—	MHz

Typical characteristics

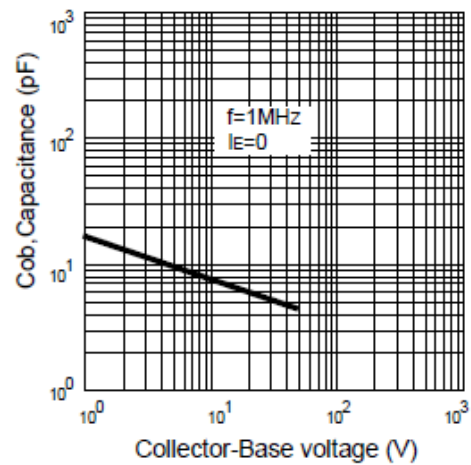
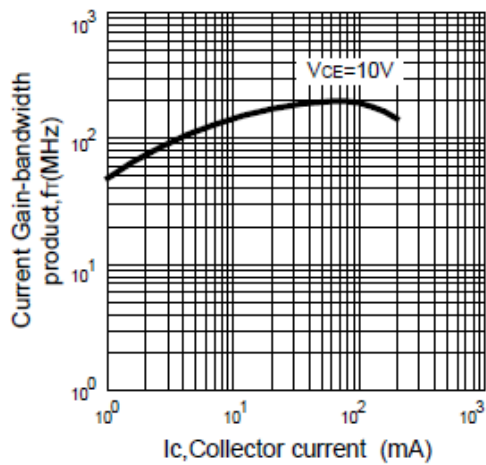
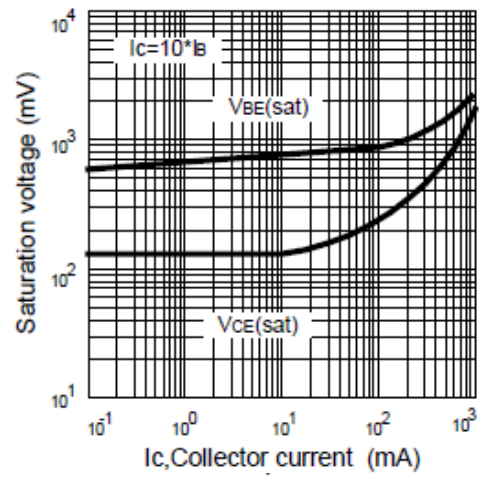
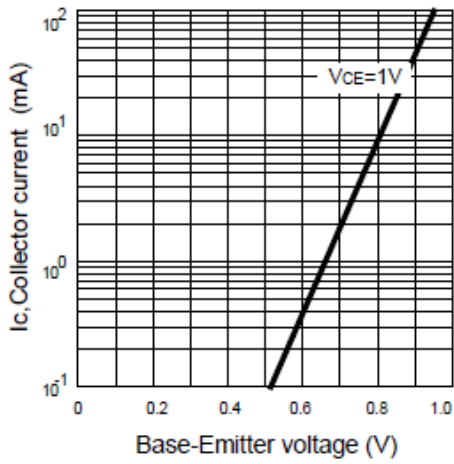
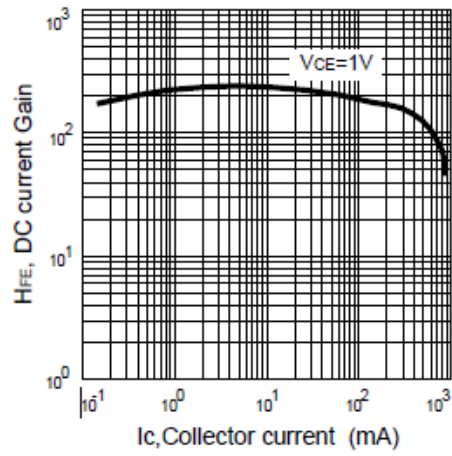
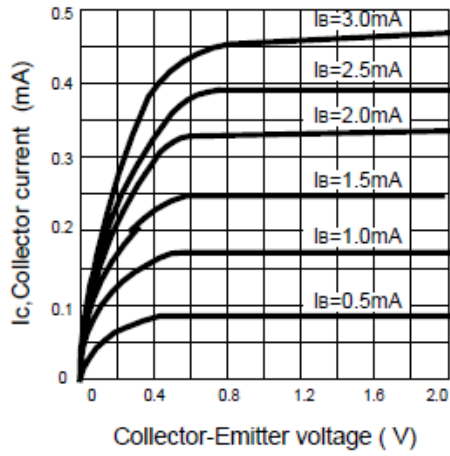

Outline dimensions (see fig.1)

Unit: mm

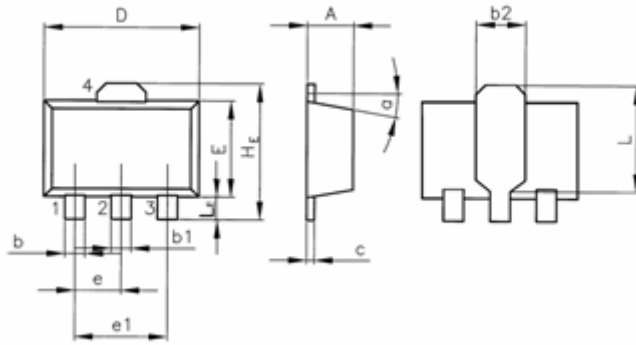

Dimensions Symbol	SOT-89		
	min	type	max
A	1.4		1.6
b	0.35		0.55
b1	0.4		0.65
b2		1.6	
c	0.35		0.45
D	4.4		4.6
E	2.35		2.55
e		1.5	
e1		3	
HE		4.15	
L		2.7	
LE		1.0	
α		5 $^{\circ}$	

Fig.1 Outline Dimensions

X-ON Electronics

Largest Supplier of Electrical and Electronic Components

Click to view similar products for [Bipolar Transistors - BJT category](#):

Click to view products by [Shikues manufacturer](#):

Other Similar products are found below :

[619691C](#) [MCH4017-TL-H](#) [MJ15024/WS](#) [MJ15025/WS](#) [BC546/116](#) [BC556/FSC](#) [BC557/116](#) [BSW67A](#) [HN7G01FU-A\(T5L,F,T](#)
[NJVMJD148T4G](#) [NSVMMBT6520LT1G](#) [NTE187A](#) [NTE195A](#) [NTE2302](#) [NTE2330](#) [NTE2353](#) [NTE316](#) [IMX9T110](#) [NTE63](#) [NTE65](#)
[C4460](#) [SBC846BLT3G](#) [2SA1419T-TD-H](#) [2SA1721-O\(TE85L,F\)](#) [2SA1727TLP](#) [2SA2126-E](#) [2SB1202T-TL-E](#) [2SB1204S-TL-E](#) [2SC5488A-](#)
[TL-H](#) [2SD2150T100R](#) [SP000011176](#) [FMC5AT148](#) [2N2369ADCSM](#) [2SB1202S-TL-E](#) [2SC2412KT146S](#) [2SC4618TLN](#) [2SC5490A-TL-H](#)
[2SD1816S-TL-E](#) [2SD1816T-TL-E](#) [CMXT2207 TR](#) [CPH6501-TL-E](#) [MCH4021-TL-E](#) [BC557B](#) [TTC012\(Q\)](#) [BULD128DT4](#) [JANTX2N3810](#)
[Jantx2N5416](#) [US6T6TR](#) [KSF350](#) [068071B](#)