

● FEATURES

- Low turn-on voltage.
- Fast switching.
- Ultra-small surface mount package.
- PN junction guard ring for transient and ESD protection.

● APPLICATIONS

- Schottky barrier detector and switching diodes.

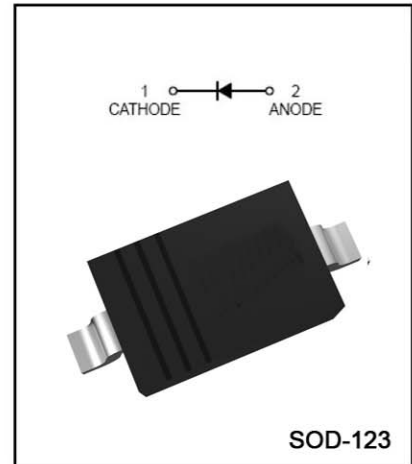

● MAXIMUM RATING @ Ta=25°C unless otherwise specified

Parameter	Symbol	Limits	Unit
Non-Repetitive Peak reverse voltage	V_{RM}	30	V
DC Reverse Voltage	V_R	21	V
Average Rectified Output Current	I_O	100	mA
Forward continuous Current	I_F	200	mA
Repetitive peak Forward Current	I_{FRM}	300	mA
Forward Surge Current	I_{FSM}	600	mA
Power Dissipation	P_d	200	mW
Thermal resistance, junction to ambient air	$R_{\theta JA}$	625	°C/W
Junction temperature	T_j	125	°C
Storage temperature range	T_{stg}	-65-150	°C

● ELECTRICAL CHARACTERISTICS @ Ta=25°C unless otherwise specified

Parameter	Symbol	Conditions	Min.	Typ.	Max.	Unit
Reverse Breakdown Voltage	$V_{(BR)R}$	$I_R=100\mu A$	30			V
Forward voltage	V_{F1}	$I_F=0.1mA$			240	mV
	V_{F2}	$I_F=1.0mA$			320	mV
	V_{F3}	$I_F=10mA$			400	mV
	V_{F4}	$I_F=30mA$			500	mV
	V_{F5}	$I_F=100mA$			1000	mV
Reverse current	I_R	$V_R=25v$			2.0	μA
Reverse recovery time	t_{rr}	$I_F=10mA, I_R=10mA$ to $1mA, R_L=100\Omega$			5.0	ns
Capacitance between terminals	C_T	$V_R=0, f=1MHz$			10	pF

TYPICAL CHARACTERISTICS @ Ta=25°C unless otherwise specified

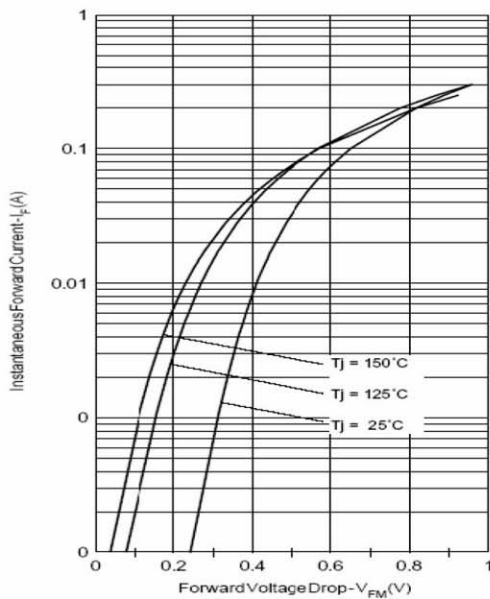

Fig. 1 - Max. Forward Voltage Drop Characteristics (Per Leg)

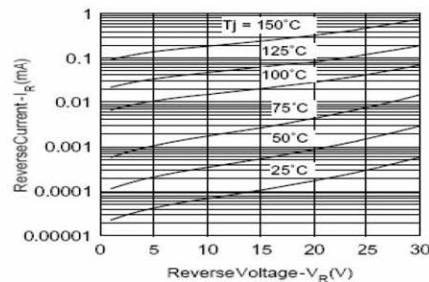

Fig. 2 - Typical Values Of Reverse Current Vs. Reverse Voltage (Per Leg)

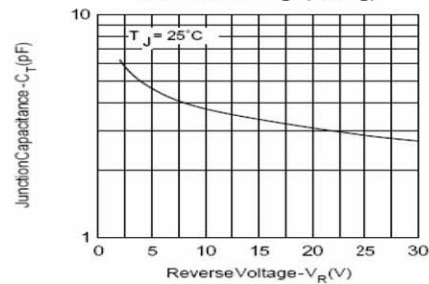

Fig. 3 - Typical Junction Capacitance Vs. Reverse Voltage (Per Leg)

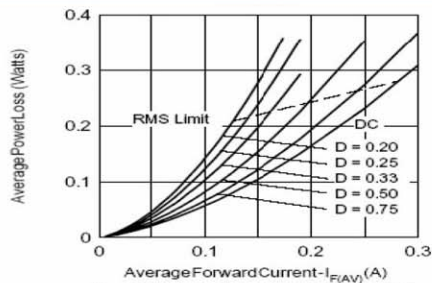

Fig. 4 - Forward Power Loss Characteristics

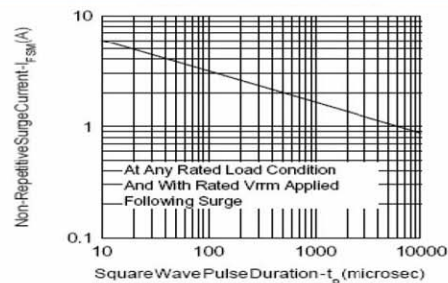
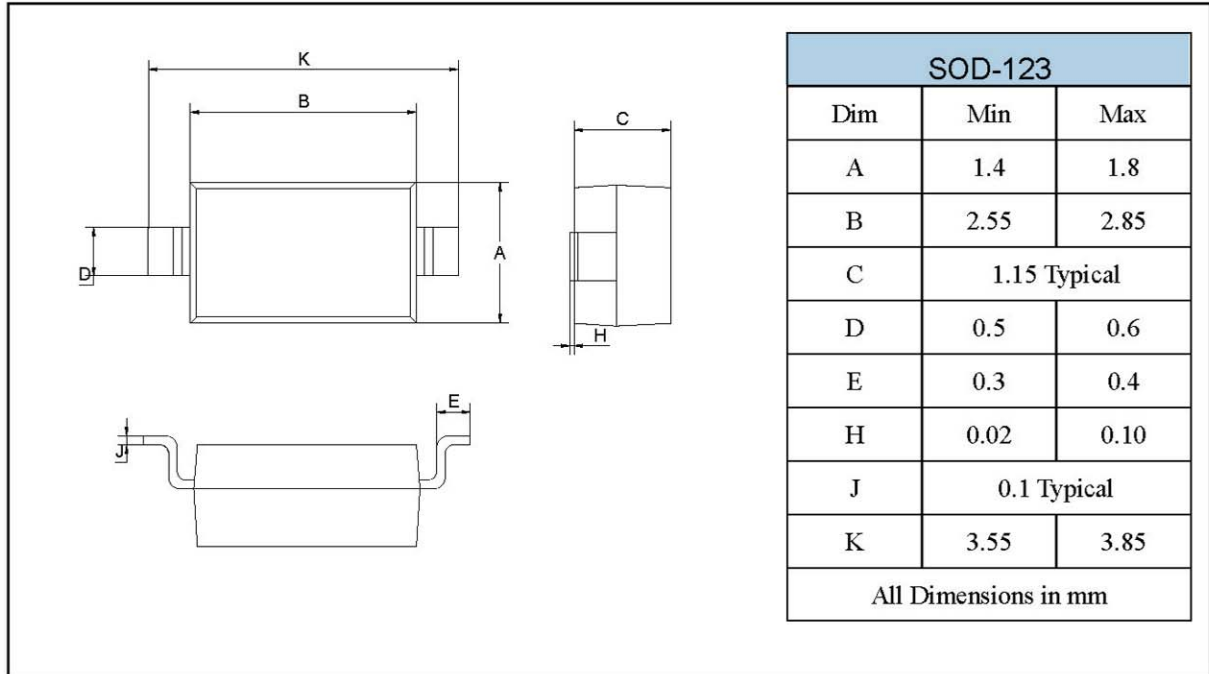

Fig. 5 - Max. Non-Repetitive Surge Current

PACKAGE OUTLINE

Plastic surface mounted package



SOLDERING FOOTPRINT

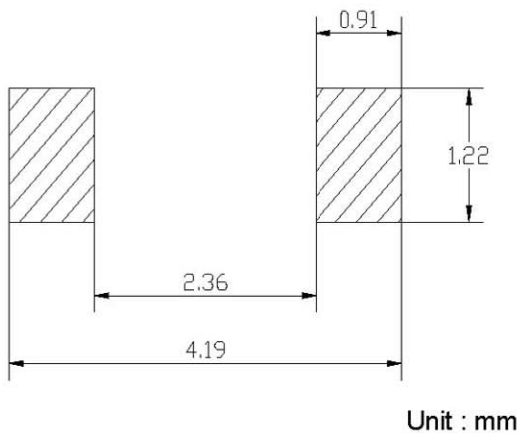

PACKAGE INFORMATION

Device	Package	Shipping
BAT54T	SOD-123	3000/Tape&Reel

X-ON Electronics

Largest Supplier of Electrical and Electronic Components

Click to view similar products for [Schottky Diodes & Rectifiers](#) category:

Click to view products by [Shikues](#) manufacturer:

Other Similar products are found below :

[CUS06\(TE85L,Q,M\)](#) [MA4E2039](#) [D1FH3-5063](#) [MBR0530L-TP](#) [MBR10100CT-BP](#) [MBR30H100MFST1G](#) [MMBD301M3T5G](#) [PMAD1103-LF](#) [PMAD1108-LF](#) [RB160M-50TR](#) [RB520S-30](#) [RB551V-30](#) [DD350N18K](#) [DZ435N40K](#) [DZ600N16K](#) [BAS16E6433HTMA1](#) [BAS 3010S-02LRH E6327](#) [BAT 54-02LRH E6327](#) [IDL02G65C5XUMA1](#) [NSR05F40QNXT5G](#) [NSVR05F40NXT5G](#) [JANS1N6640](#) [SB07-03C-TB-H](#) [SB1003M3-TL-W](#) [SBAT54CWT1G](#) [SBM30-03-TR-E](#) [SBS818-TL-E](#) [SK32A-LTP](#) [SK33A-TP](#) [SK34A-TP](#) [SK34B-TP](#) [SMD1200PL-TP](#) [ACDBN160-HF](#) [SS3003CH-TL-E](#) [STPS30S45CW](#) [PDS3100Q-7](#) [GA01SHT18](#) [CRS10I30A\(TE85L,QM\)](#) [MBR1240MFST1G](#) [MBRB30H30CT-1G](#) [BAS28E6433HTMA1](#) [BAS 70-02L E6327](#) [HSB123JTR-E](#) [JANTX1N5712-1](#) [VS-STPS40L45CW-N3](#) [DD350N12K](#) [SB007-03C-TB-E](#) [SB10015M-TL-E](#) [SB1003M3-TL-E](#) [SK110-LTP](#)