

Low Capacitance TVS /ESD Protection Diode

DESCRIPTION

The ESD5L5.0C is designed to protect voltage sensitive components from ESD and transient voltage events. Excellent clamping capability, low leakage, and fast response time, make these parts ideal for ESD protection on designs where board space is at a premium. Because of its small size, it is suited for use in cellular phones, portable devices, digital cameras, power supplies and many other portable applications where board space comes at a premium. Also because of its low capacitance, it is suited for use in high frequency designs such as USB 2.0 high speed, VGA, DVI, SDI and other high speed line applications.

This device has been specifically designed to protect sensitive components which are connected to data and transmission lines from overvoltage caused by ESD (electrostatic discharge), and EFT (electrical fast transients).

ORDERING INFORMATION

- ✧ Device: ESD5L5.0C
- ✧ Package: SOD-523
- ✧ Marking: D5
- ✧ Material: RoHS compliant, Halogen free
- ✧ Packing: Tape & Reel
- ✧ Quantity per reel: 10,000pcs

CIRCUIT DIAGRAM

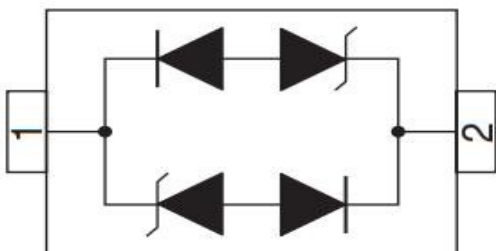

FEATURES

- ✧ Transient protection for high-speed datalines
IEC 61000-4-2 (ESD) ±15kV (Air)
±8kV (Contact)
IEC 61000-4-4 (EFT) 40A (5/50 ns)
Cable Discharge Event (CDE)
- ✧ Package optimized for high-speed lines
- ✧ Ultra-small package (1.0mm×0.6mm×0.4mm)
- ✧ Protects one data, control or power line
- ✧ Low capacitance
- ✧ Low leakage current
- ✧ Low clamping voltage
- ✧ Each I/O pin can withstand over 1000 ESD strikes for ±8kV contact discharge

MACHANICAL DATA

- ✧ SOD-523 package
- ✧ Flammability Rating: UL 94V-0
- ✧ Packaging: Tape and Reel
- ✧ High temperature soldering guaranteed: 260°C/10s
- ✧ Reel size: 7 inch
- ✧ MSL3

APPLICATIONS

- ✧ High Speed Line : USB1.0/2.0, VGA, DVI, SDI
- ✧ Serial and Parallel Ports
- ✧ Notebooks, Desktops, Servers
- ✧ Projection TV
- ✧ Cellular handsets and accessories
- ✧ Portable instrumentation
- ✧ Peripherals



ABSOLUTE MAXIMUM RATING			
Symbol	Parameter	Value	Units
P_{PP}	Peak Pulse Power (8/20 μ s)	100	W
I_{PP}	Peak Pulse Current (8/20 μ s)	4.5	A
V_{ESD}	ESD per IEC 61000-4-2 (Air) ESD per IEC 61000-4-2 (Contact)	± 25 ± 22	kV
T_{OPT}	Operating Temperature	-55/+125	$^{\circ}$ C
T_{STG}	Storage Temperature	-55/+150	$^{\circ}$ C

ELECTRICAL CHARACTERISTICS ($T_{amb}=25$)						
Symbol	Parameter	Test Condition	Min	Typ	Max	Units
V_{RWM}	Reverse Working Voltage				5.0	V
V_{BR}	Reverse Breakdown Voltage	$I_T = 1mA$	7.0		11.0	V
I_R	Reverse Leakage Current	$V_{RWM} = 5V$		0.01	1.0	μ A
V_C	Clamping Voltage	$I_{PP} = 1A, t_p = 8/20\mu s$			12	V
V_C	Clamping Voltage	$I_{PP} = 4A, t_p = 8/20\mu s$			20	V
C_J	Junction Capacitance	$V_R = 0V, f = 1MHz$		0.25	0.40	pF

Clamping Voltage vs. Peak Pulse Current

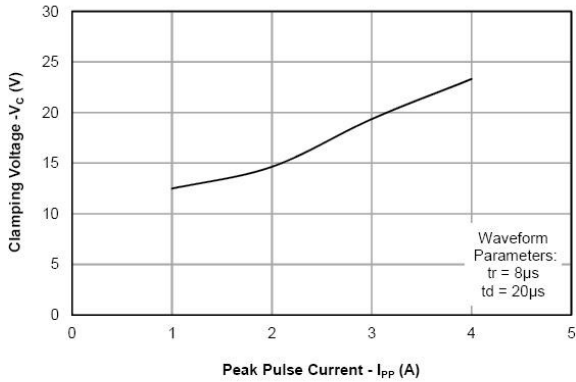

Typical Capacitance vs. Reverse Voltage

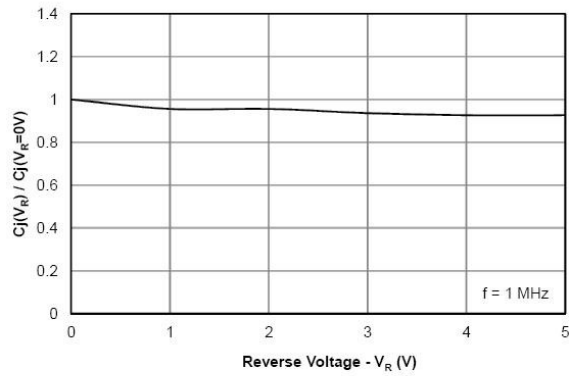

Typical Insertion Loss (S21)

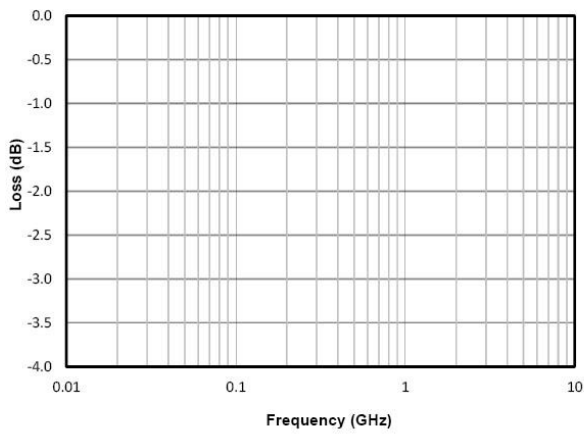

TLP Characteristic

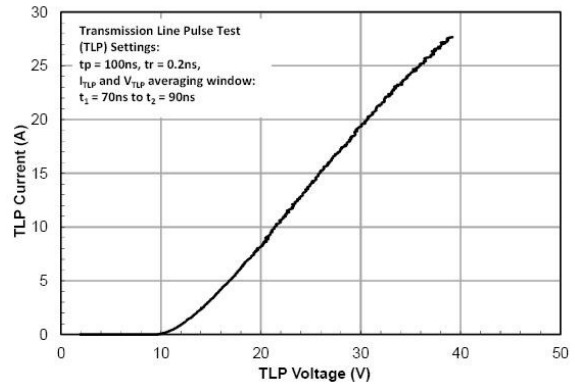

ESD Clamping (+8kV Contact per IEC 61000-4-2)

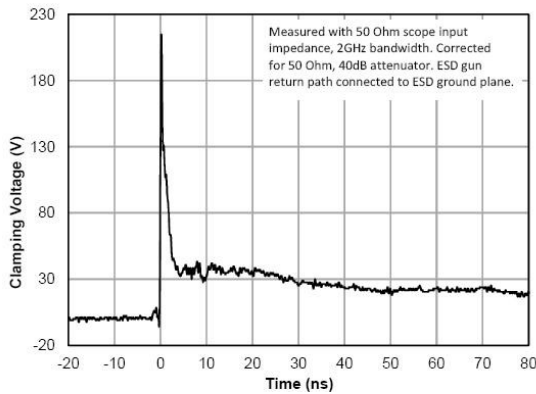

ESD Clamping (-8kV Contact per IEC 61000-4-2)

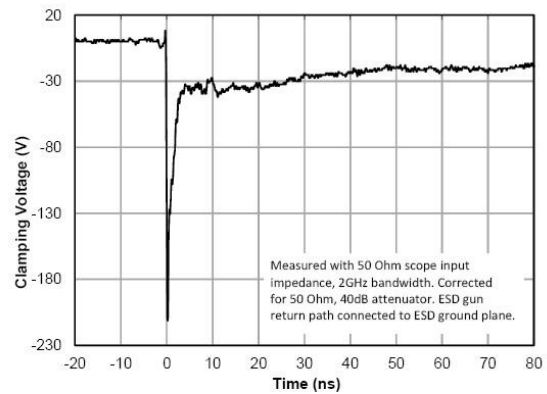

PACKAGE OUTLINE

Plastic surface mounted package; 2 leads

SOD523

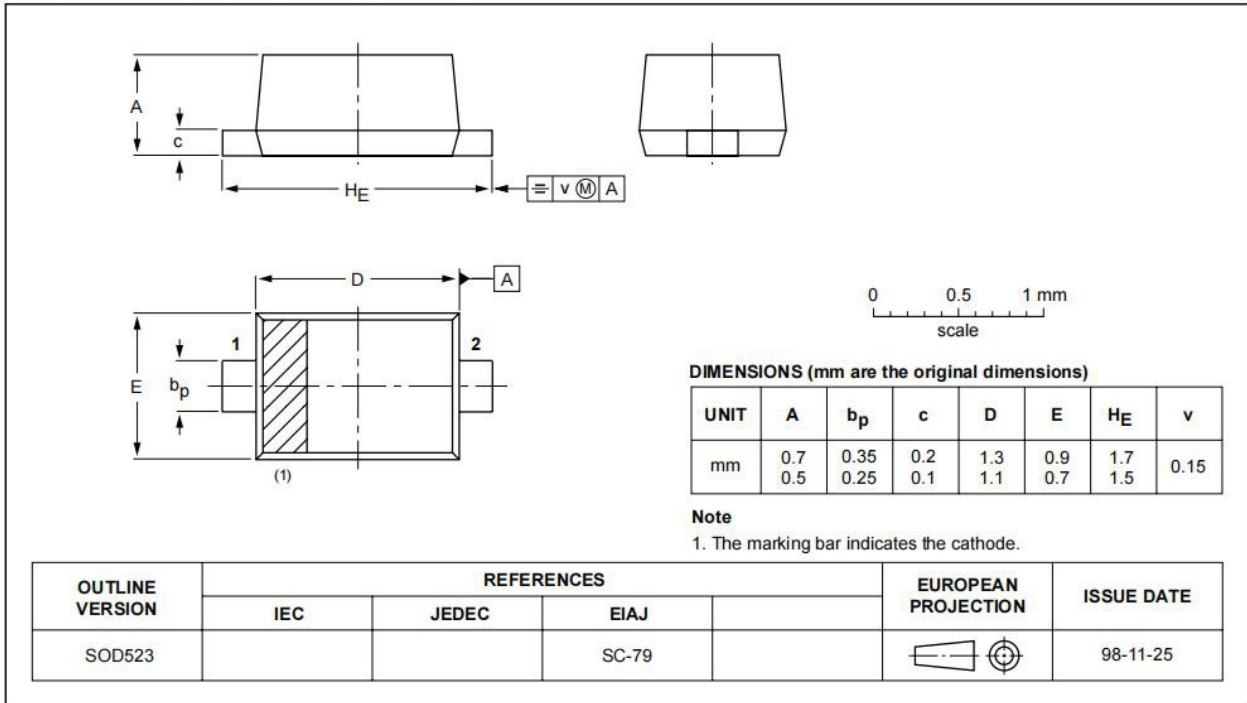

X-ON Electronics

Largest Supplier of Electrical and Electronic Components

Click to view similar products for [ESD Suppressors / TVS Diodes](#) category:

Click to view products by [Shikues](#) manufacturer:

Other Similar products are found below :

[60KS200C](#) [D18V0L1B2LP-7B](#) [D5V0F4U5P5-7](#) [NTE4902](#) [P4KE27CA](#) [P6KE11CA](#) [P6KE8.2A](#) [SA60CA](#) [SA64CA](#) [SMBJ12CATR](#)
[SMBJ33CATR](#) [SMBJ6.5A](#) [SMBJ8.0A](#) [ESD101-B1-02ELS](#) [E6327](#) [ESD112-B1-02EL](#) [E6327](#) [ESD7451N2T5G](#) [19180-510](#) [CPDT-5V0USP-](#)
[HF](#) [3.0SMCJ33CA-F](#) [3.0SMCJ36A-F](#) [HSPC16701B02TP](#) [JANTX1N6126A](#) [D3V3Q1B2DLP3-7](#) [D55V0M1B2WS-7](#) [SCM1293A-04SO](#)
[ESD200-B1-CSP0201](#) [E6327](#) [SM12-7](#) [CEN955](#) [W/DATA](#) [VESD12A1A-HD1-GS08](#) [CPDQC5V0-HF](#) [D1213A-01LP4-7B](#) [ESD101-B1-02EL](#)
[E6327](#) [AOZ8808DI-03](#) [5KP15A](#) [5KP48A](#) [5KP90A](#) [ESD3V3D7-TP](#) [15KPA36A-LF](#) [P4KE56CA](#) [P4KE68A](#) [P4KE91CATR](#) [P6KE120A](#)
[P6KE13CA](#) [P6KE43CA](#) [P6KE6.8CA](#) [P6KE8.2](#) [P6SMBJ20CA](#) [JANTX1N6072A](#) [SR2835ESKG](#) [SA90CA](#)