

800V N-Channel MOSFET

General Features

- Proprietary New Planar Technology
- $R_{DS(ON),typ.}=1.5\ \Omega@V_{GS}=10V$
- Low Gate Charge Minimize Switching Loss
- Fast Recovery Body Diode

BV_{DSS}	$R_{DS(ON),typ.}$	I_D
800V	1.5 Ω	7.0A

Applications

- Adaptor
- LCD Panel Power
- Other Applications

Ordering Information

Part Number	Package
	TO-220F

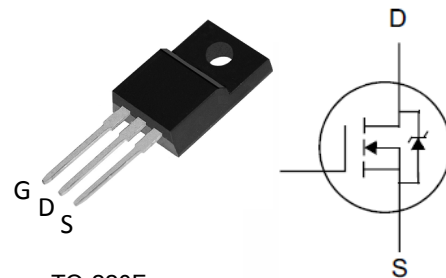

TO-220F

Package Not to Scale

Absolute Maximum Ratings

$T_C=25$ unless otherwise specified

Symbol	Parameter	TO-220F	Unit
V_{DSS}	Drain-to-Source Voltage ^[1]	800	V
V_{GSS}	Gate-to-Source Voltage	± 30	
I_D	Continuous Drain Current	7.0	A
$I_D @ T_C=100^\circ C$	Continuous Drain Current @ $T_C=100^\circ C$	Figure 3	
I_{DM}	Pulsed Drain Current at $V_{GS}=10V^{[2]}$	Figure 6	
E_{AS}	Single Pulse Avalanche Energy	580	mJ
dv/dt	Peak Diode Recovery $dv/dt^{[3]}$	5.0	V/ns
P_D	Power Dissipation	40	W
	Derating Factor above 25 $^\circ C$	0.32	W/ $^\circ C$
T_L T_{PAK}	Maximum Temperature for Soldering Leads at 0.063in (1.6mm) from Case for 10 seconds, Package Body for 10 seconds	300 260	$^\circ C$
T_J & T_{STG}	Operating and Storage Temperature Range	-55 to 150	

Caution: Stresses greater than those listed in the "Absolute Maximum Ratings" may cause permanent damage to the device.

Thermal Characteristics

Symbol	Parameter	TO-220F	Unit
$R_{\theta JC}$	Thermal Resistance, Junction-to-Case	3.125	$^\circ C/W$
$R_{\theta JA}$	Thermal Resistance, Junction-to-Ambient	100	

Electrical Characteristics

OFF Characteristics $T_J = 25^\circ\text{C}$ unless otherwise specified

Symbol	Parameter	Min.	Typ.	Max.	Unit	Test Conditions
BV_{DSS}	Drain-to-Source Breakdown Voltage	800	--	--	V	$V_{GS}=0V, I_D=250\mu A$
I_{DSS}	Drain-to-Source Leakage Current	--	--	1	μA	$V_{DS}=800V, V_{GS}=0V$
		--	--	100		$V_{DS}=640V, V_{GS}=0V, T_J=125^\circ\text{C}$
I_{GSS}	Gate-to-Source Leakage Current	1 of 8	--	+100	nA	$V_{GS}=+30V, V_{DS}=0V$
		--	--	-100		$V_{GS}=-30V, V_{DS}=0V$

ON Characteristics

 $T_J = 25^\circ\text{C}$ unless otherwise specified

Symbol	Parameter	Min.	Typ.	Max.	Unit	Test Conditions
$R_{DS(ON)}$	Static Drain-to-Source On-Resistance ^[4]	--	1.5	1.8	Ω	$V_{GS}=10V, I_D=3.5A$
$V_{GS(TH)}$	Gate Threshold Voltage	2.0	--	4.0	V	$V_{DS}=V_{GS}, I_D=250\mu A$
gfs	Forward Transconductance ^[4]	--	5.5	--	S	$V_{DS}=30V, I_D=7.0A$

Dynamic Characteristics

Essentially independent of operating temperature

Symbol	Parameter	Min.	Typ.	Max.	Unit	Test Conditions
C_{iss}	Input Capacitance	--	1350	--	pF	$V_{GS}=0V, V_{DS}=25V, f=1.0MHz$
C_{rss}	Reverse Transfer Capacitance	--	12	--		
C_{oss}	Output Capacitance	--	120	--		
Q_g	Total Gate Charge	--	34	--	nC	$V_{DD}=400V, I_D=7.0A, V_{GS}=0 \text{ to } 10V$
Q_{gs}	Gate-to-Source Charge	--	6.0	--		
Q_{gd}	Gate-to-Drain (Miller) Charge	--	14	--		

Resistive Switching Characteristics

Essentially independent of operating temperature

Symbol	Parameter	Min.	Typ.	Max.	Unit	Test Conditions
$t_{d(ON)}$	Turn-on Delay Time	--	15	--	nS	$V_{DD}=400V, I_D=7.0A, V_{GS}=10V, R_G=12\Omega$
t_{rise}	Rise Time	--	25	--		
$t_{d(OFF)}$	Turn-Off Delay Time	--	50	--		
t_{fall}	Fall Time	--	30	--		

Source-Drain Body Diode Characteristics

$T_J=25^{\circ}\text{C}$ unless otherwise specified

Symbol	Parameter	Min	Typ.	Max.	Unit	Test Conditions
I_{SD}	Continuous Source Current ^[4]	--	--	7.0	A	Integral PN-diode in MOSFET
I_{SM}	Pulsed Source Current ^[4]	--	--	28		
V_{SD}	Diode Forward Voltage	--	--	1.5	V	$I_S=7.0\text{A}$, $V_{GS}=0\text{V}$
trr	Reverse recovery time	--	185	--	ns	$V_{GS}=0\text{V}$, $I_F=7.0\text{A}$, $di_F/dt=100\text{A}/\mu\text{s}$
Qrr	Reverse recovery charge	--	0.85	--	uC	

Typical Characteristics

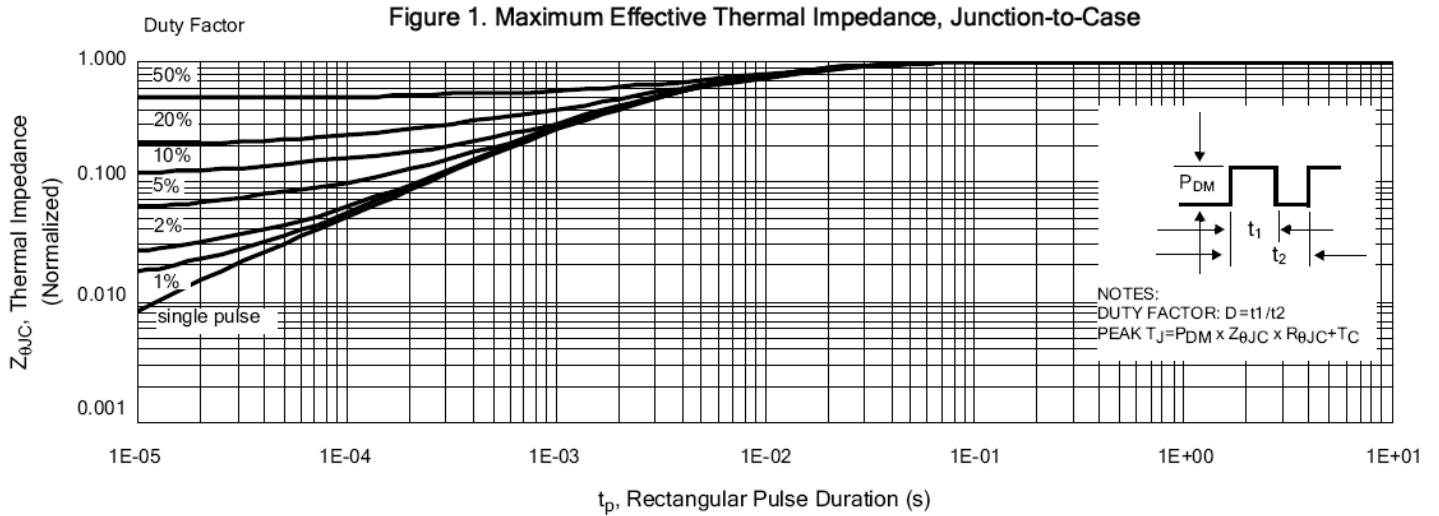

Figure 2. Maximum Power Dissipation vs Case Temperature

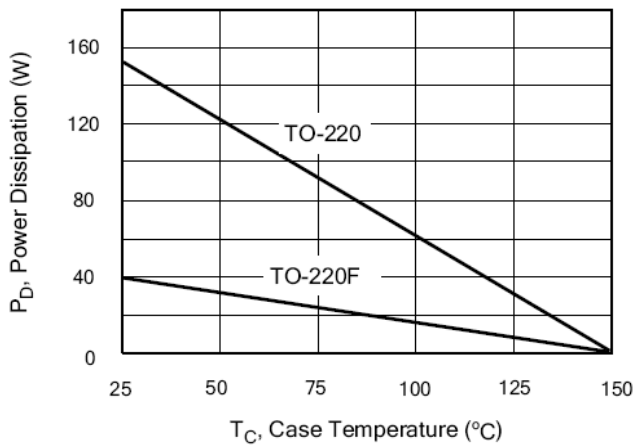

Figure 3. Maximum Continuous Drain Current vs Case Temperature

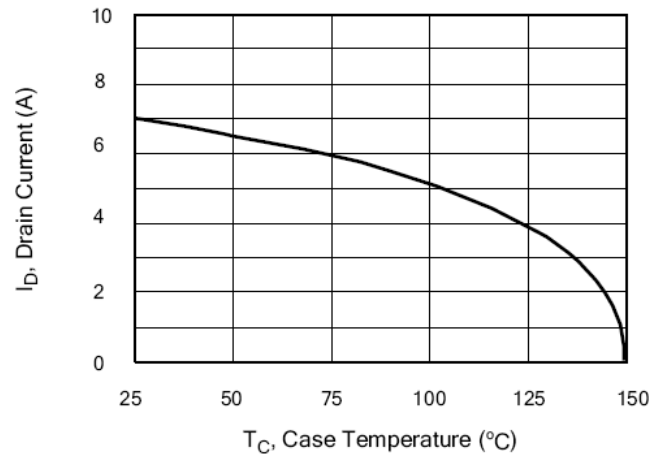

Figure 4. Typical Output Characteristics

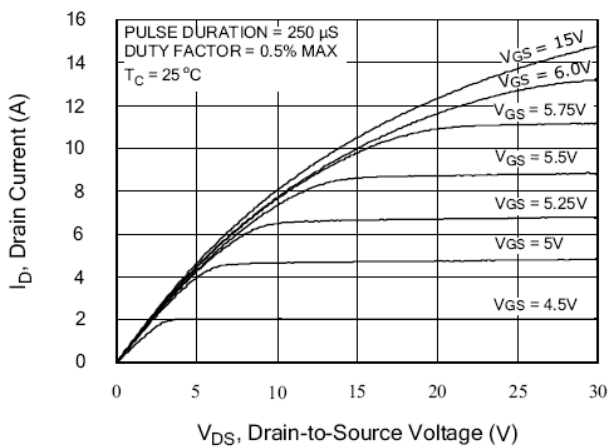
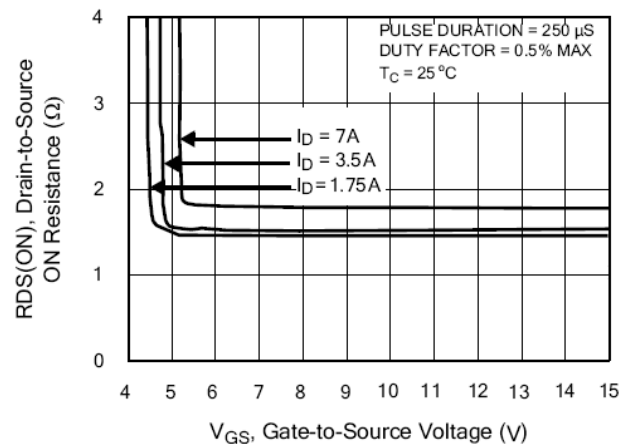

Figure 5. Typical Drain-to-Source ON Resistance vs Gate Voltage and Drain Current



Typical Characteristics(Cont.)

Figure 6. Maximum Peak Current Capability

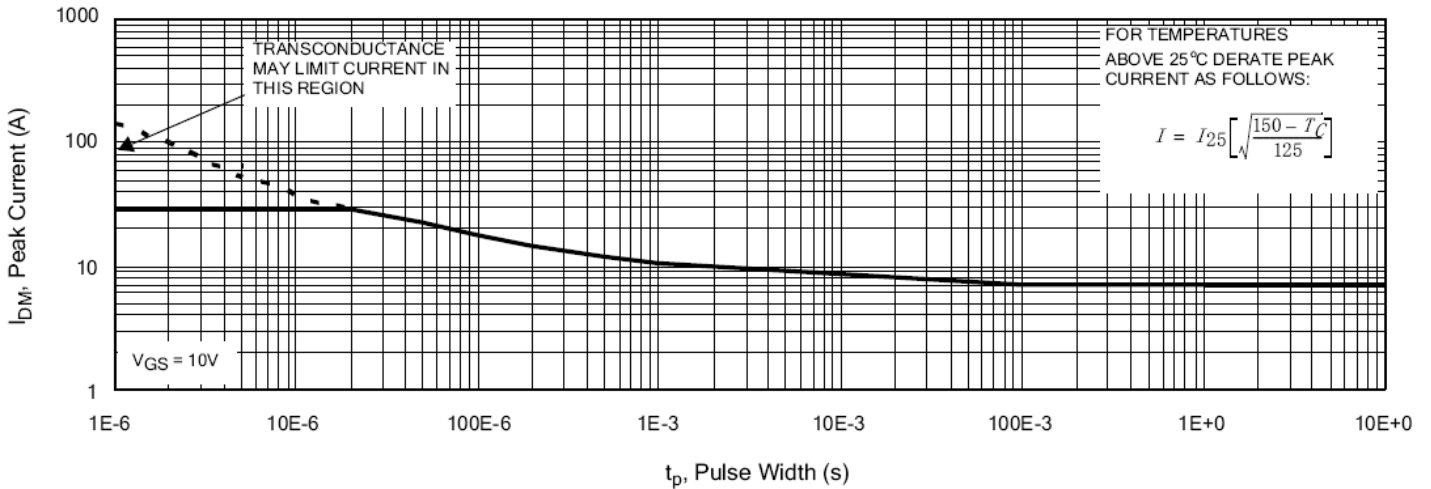

Figure 7. Typical Transfer Characteristics

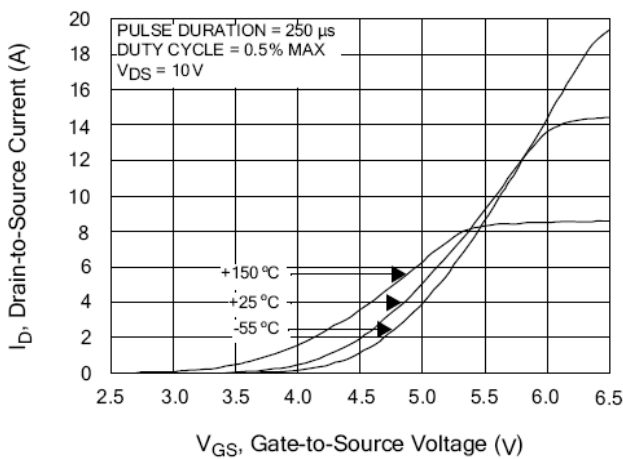

Figure 8. Unclamped Inductive Switching Capability

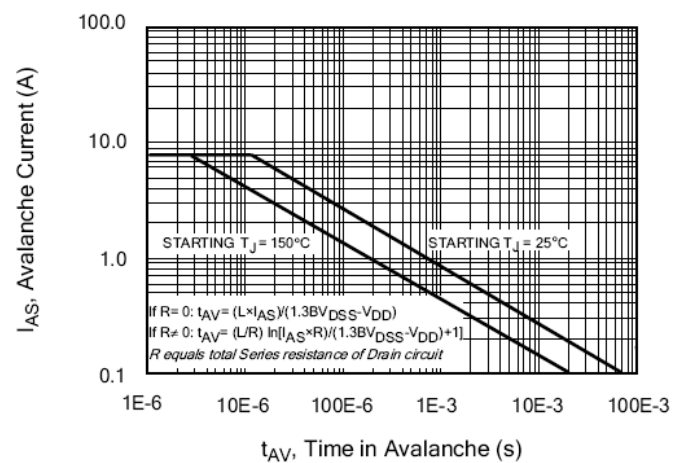

Figure 9. Typical Drain-to-Source ON Resistance vs Drain Current

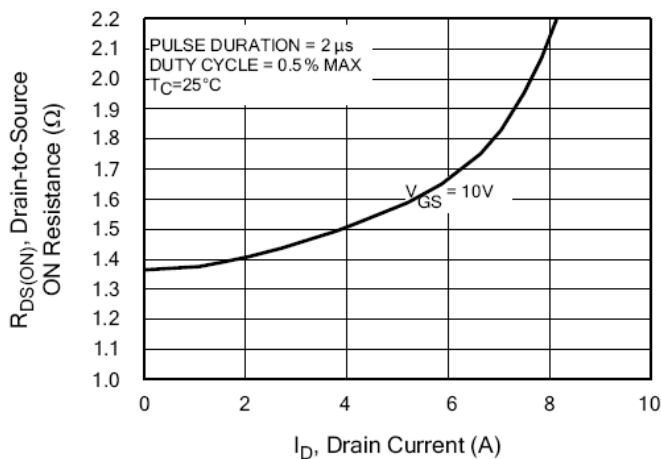
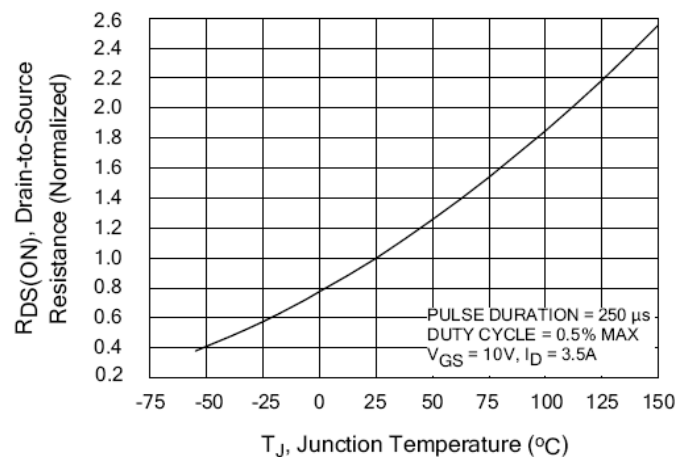

Figure 10. Typical Drain-to-Source ON Resistance vs Junction Temperature



Typical Characteristics(Cont.)

Figure 11. Typical Breakdown Voltage vs Junction Temperature

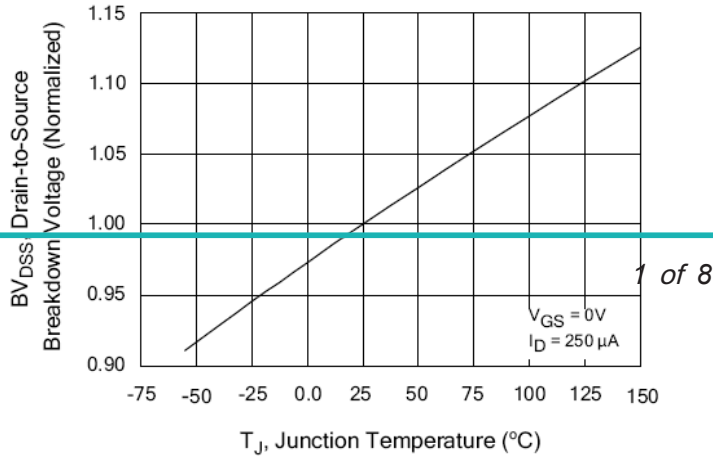

Figure 12. Typical Threshold Voltage vs Junction Temperature

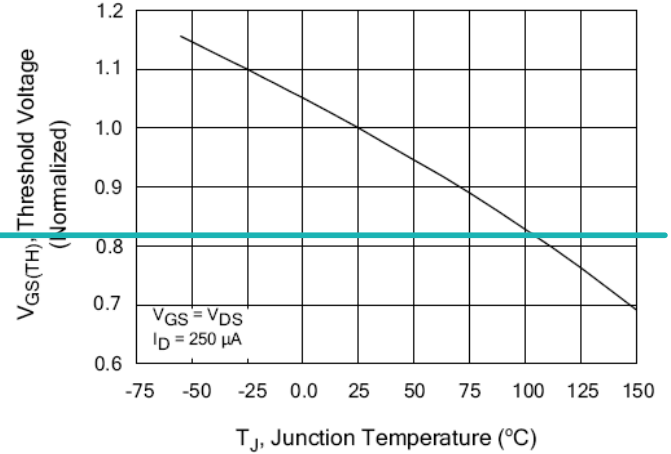

Figure 13. Maximum Forward Bias Safe Operating Area

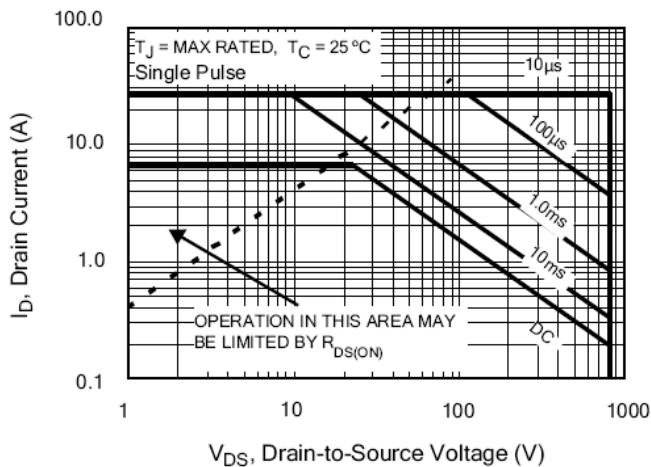

Figure 14. Typical Capacitance vs Drain-to-Source Voltage

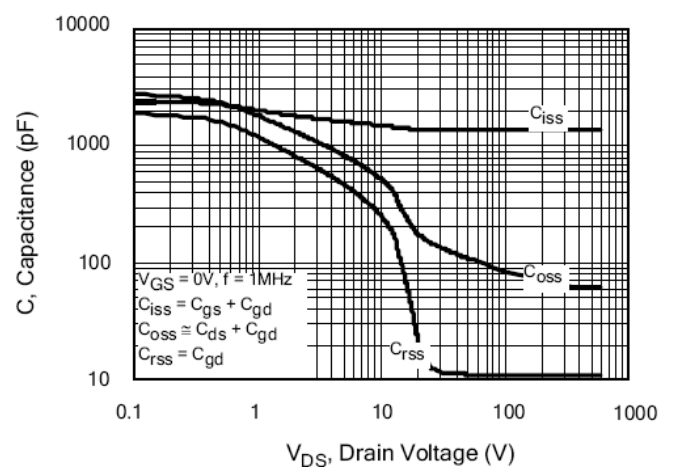

Figure 15. Typical Gate Charge vs Gate-to-Source Voltage

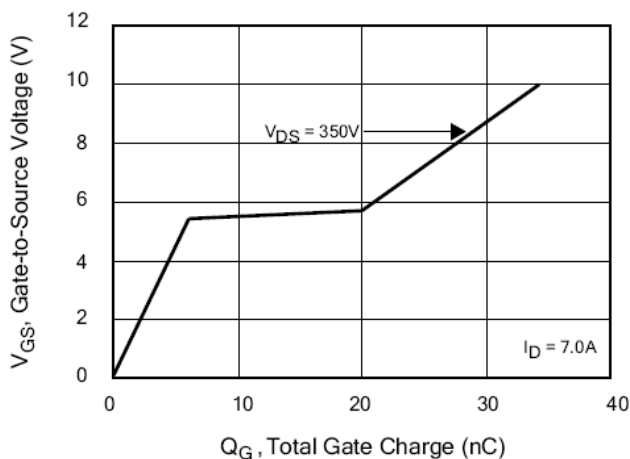
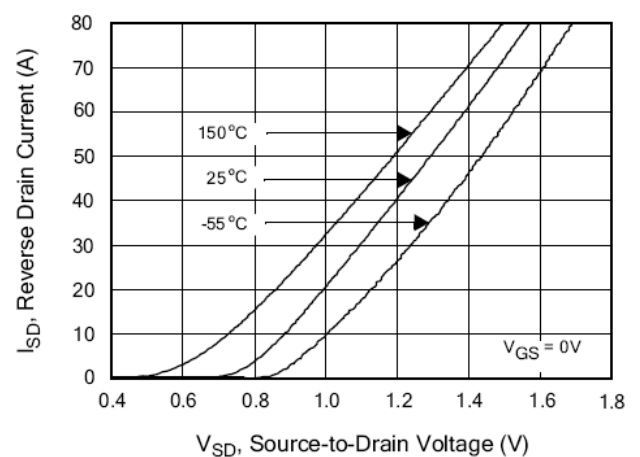

Figure 16. Typical Body Diode Transfer Characteristics



Test Circuits and Waveforms

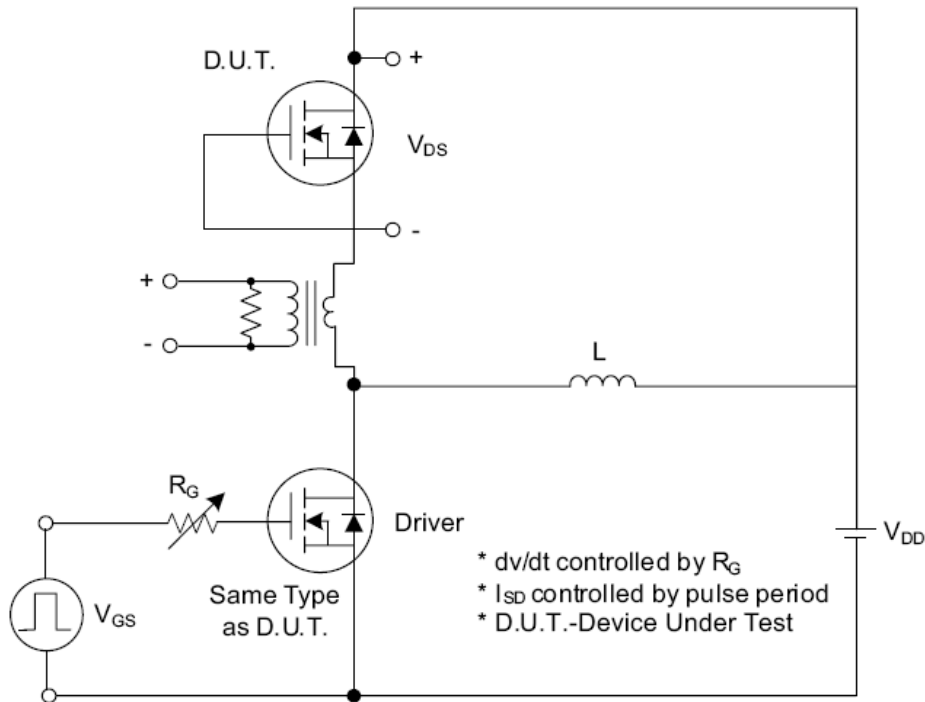

Fig. 1.1 Peak Diode Recovery dv/dt Test Circuit

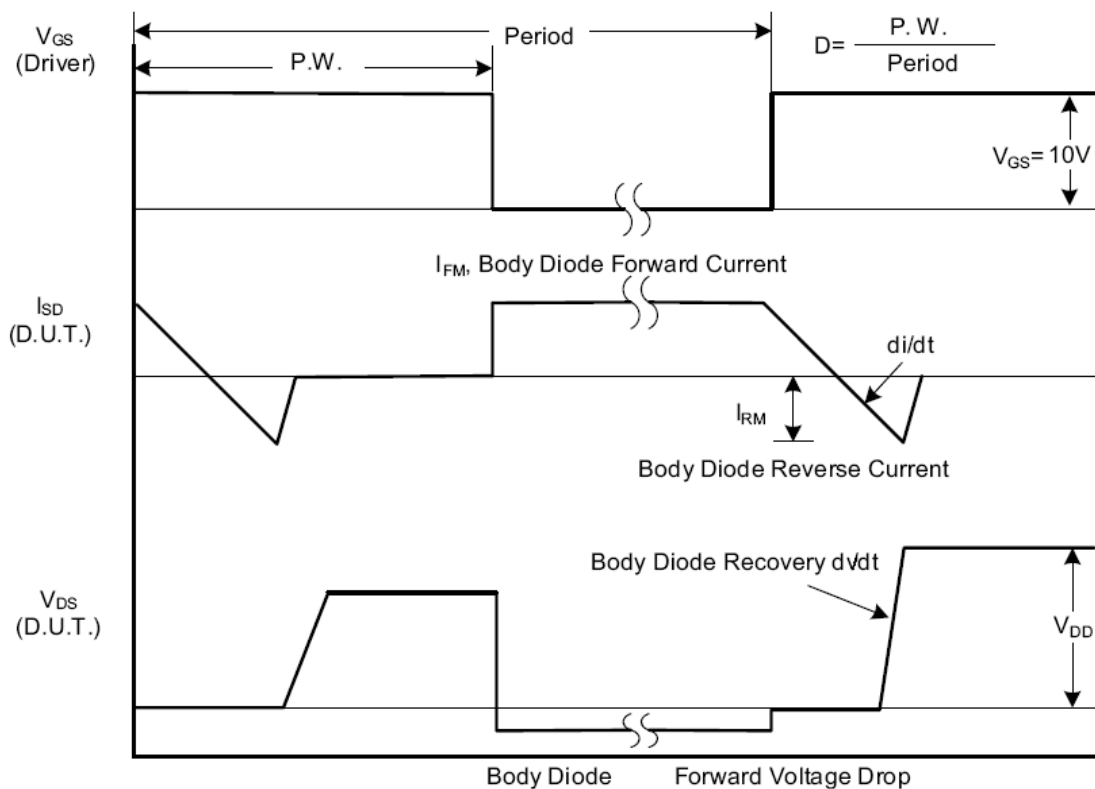

Fig. 1.2 Peak Diode Recovery dv/dt Waveforms

Test Circuits and Waveforms (Cont.)

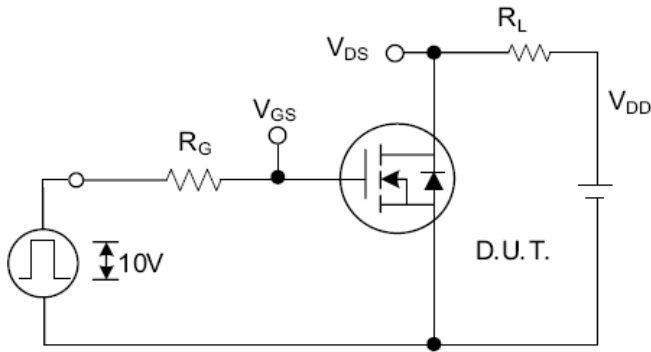

Fig. 2.1 Switching Test Circuit

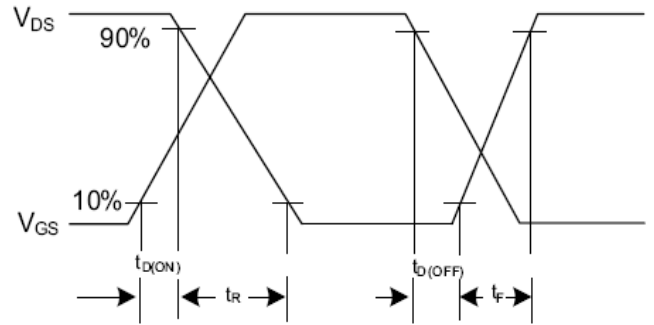

Fig. 2.2 Switching Waveforms

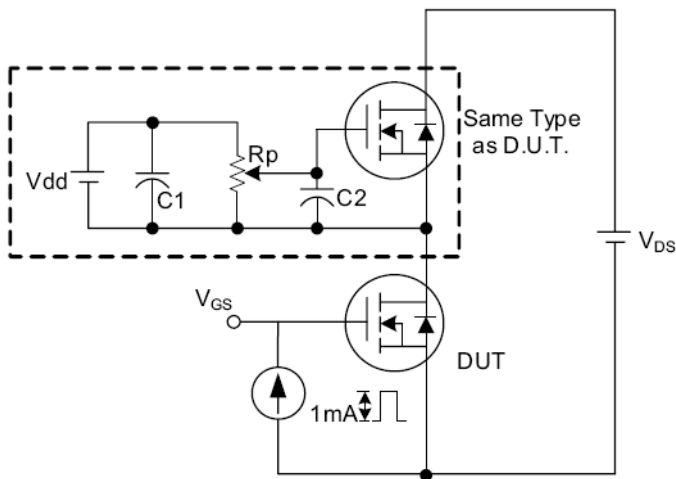

Fig. 3.1 Gate Charge Test Circuit

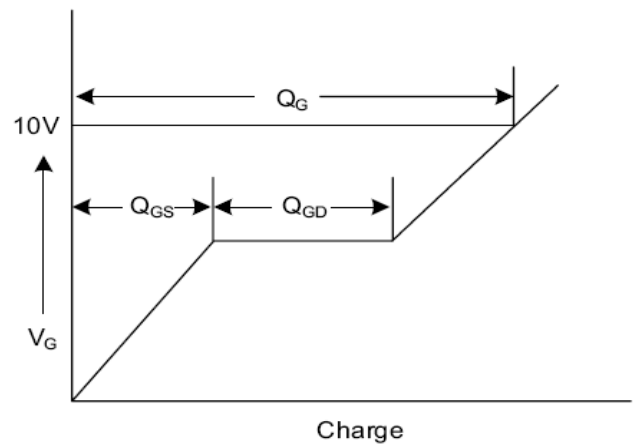

Fig. 3.2 Gate Charge Waveform

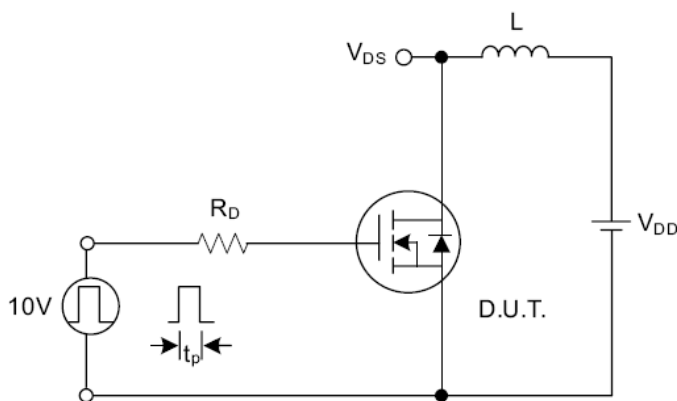

Fig. 4.1 Unclamped Inductive Switching Test Circuit

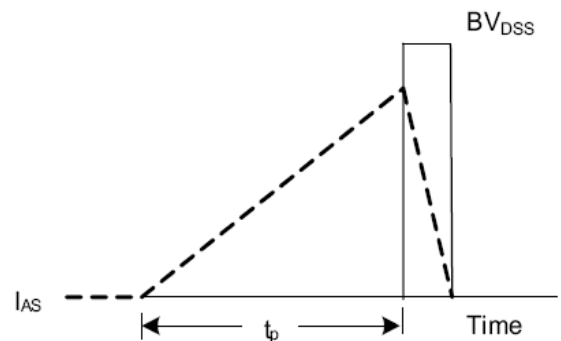

Fig. 4.2 Unclamped Inductive Switching Waveforms

X-ON Electronics

Largest Supplier of Electrical and Electronic Components

Click to view similar products for [MOSFET](#) category:

Click to view products by [Shikues](#) manufacturer:

Other Similar products are found below :

[IRFD120](#) [JANTX2N5237](#) [BUK455-60A/B](#) [MIC4420CM-TR](#) [VN1206L](#) [NDP4060](#) [SI4482DY](#) [IPS70R2K0CEAKMA1](#) [SQD23N06-31L-GE3](#)
[TK16J60W,S1VQ\(O](#) [2SK2614\(TE16L1,Q\)](#) [DMN1017UCP3-7](#) [DMN1053UCP4-7](#) [SQJ469EP-T1-GE3](#) [NTE2384](#) [DMC2700UDMQ-7](#)
[DMN2080UCB4-7](#) [DMN61D9UWQ-13](#) [US6M2GTR](#) [DMN31D5UDJ-7](#) [DMP22D4UFO-7B](#) [DMN1006UCA6-7](#) [DMN16M9UCA6-7](#)
[STF5N65M6](#) [IRF40H233XTMA1](#) [STU5N65M6](#) [DMN6022SSD-13](#) [DMN13M9UCA6-7](#) [DMTH10H4M6SPS-13](#) [DMN2990UFB-7B](#)
[IPB80P04P405ATMA2](#) [2N7002W-G](#) [MCAC30N06Y-TP](#) [MCQ7328-TP](#) [NTMC083NP10M5L](#) [BXP7N65D](#) [BXP4N65F](#) [AOL1454G](#)
[WMJ80N60C4](#) [BXP2N20L](#) [BXP2N65D](#) [BXT1150N10J](#) [BXT1700P06M](#) [TSM60NB380CP](#) [ROG](#) [RQ7L055BGTGR](#) [DMNH15H110SK3-13](#)
[SLF10N65ABV2](#) [BSO203SP](#) [BSO211P](#) [IPA60R230P6](#)