

30V N-Channel MOSFET

BV_{DSS}	$R_{DS(ON),typ.}$	I_D
30V	3.7m Ω	120A

General Features

- Proprietary New Trench Technology
- $R_{DS(ON),typ.}=3.7m\Omega@V_{GS}=10V$
- Low Gate Charge Minimize Switching Loss
- Fast Recovery Body Diode

Applications

- High efficiency DC/DC Converters
- Motor Bridge Switch
- Oring FET/Load Switching

Ordering Information

Part Number	Package
SK120N03B	TO-252

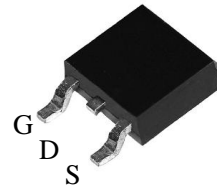

TO-252

Package No to Scale

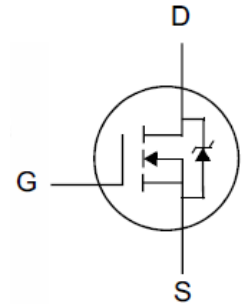

Absolute Maximum Ratings $T_C=25^\circ\text{C}$ unless otherwise specified

Symbol	Parameter	SK120N03B	Unit
V_{DSS}	Drain-to-Source Voltage ^[1]	30	V
V_{GSS}	Gate-to-Source Voltage	± 20	
I_D	Continuous Drain Current $T_C=25^\circ\text{C}$	120	A
I_{DM}	Pulsed Drain Current at $V_{GS}=10V$	480	
E_{AS}	Single Pulse Avalanche Energy	200	mJ
dv/dt	Peak Diode Recovery dv/dt ^[3]	5.0	V/ns
P_D	Power Dissipation $T_C=25^\circ\text{C}$	120	W
	Power Dissipation $T_A=25^\circ\text{C}$	0.8	
	Derating Factor above 25 $^\circ\text{C}$	0.031	
T_L T_{PAK}	Maximum Temperature for Soldering Leads at 0.063in (1.6mm) from Case for 10 seconds, Package Body for 10 seconds	300 260	$^\circ\text{C}$
T_J & T_{STG}	Operating and Storage Temperature Range	-55 to 150	

Caution: Stresses greater than those listed in the "Absolute Maximum Ratings" may cause permanent damage to the device.

Thermal Characteristics

Symbol	Parameter	SK120N03B	Unit
$R_{\theta JC}$	Thermal Resistance, Junction-to-Case	1.25	$^\circ\text{C/W}$
$R_{\theta JA}$	Thermal Resistance, Junction-to-Ambient	75	

Electrical Characteristics

OFF Characteristics $T_J=25^\circ\text{C}$ unless otherwise specified

Symbol	Parameter	Min.	Typ.	Max.	Unit	Test Conditions
BV_{DSS}	Drain-to-Source Breakdown Voltage	30	--	--	V	$V_{GS}=0V, I_D=250\mu A$
I_{DSS}	Drain-to-Source Leakage Current	--	--	1	μA	$V_{DS}=30V, V_{GS}=0V$
I_{GSS}	Gate-to-Source Leakage Current	--	--	+100	nA	$V_{GS}=+20V, V_{DS}=0V$
		--	--	-100		$V_{GS}=-20V, V_{DS}=0V$

ON Characteristics

 $T_J=25^\circ\text{C}$ unless otherwise specified

Symbol	Parameter	Min.	Typ.	Max.	Unit	Test Conditions
$R_{DS(ON)}$	Static Drain-to-Source On-Resistance	--	3.7	4	m Ω	$V_{GS}=10V, I_D=20A$
		--	3.9	6		$V_{GS}=4.5V, I_D=20A$
$V_{GS(TH)}$	Gate Threshold Voltage	1.0	1.7	3.0	V	$V_{DS}=V_{GS}, I_D=250\mu A$

Dynamic Characteristics

Essentially independent of operating temperature

Symbol	Parameter	Min.	Typ.	Max.	Unit	Test Conditions	
C_{iss}	Input Capacitance	--	3385	--	pF	$V_{GS}=0V,$ $V_{DS}=25V,$ $f=1.0MHz$	
C_{rss}	Reverse Transfer Capacitance	--	338	--			
C_{oss}	Output Capacitance	--	469	--			
Q_g	Total Gate Charge	--	81	--	nC	$V_{DD}=20V,$ $I_D=30A,$ $V_{GS}=0$ to 10V	
		--	43	--			
Q_{gs}	Gate-to-Source Charge	--	12	--			$V_{GS}=0$ to 4.5V
Q_{gd}	Gate-to-Drain (Miller) Charge	--	20	--			

Resistive Switching Characteristics

Essentially independent of operating temperature

Symbol	Parameter	Min.	Typ.	Max.	Unit	Test Conditions
$t_{d(ON)}$	Turn-on Delay Time	--	16	--	ns	$V_{DD}=20V,$ $I_D=30A,$ $V_{GS}=10V$ $R_G=3.0\Omega$
t_{rise}	Rise Time	--	12	--		
$t_{d(OFF)}$	Turn-Off Delay Time	--	89	--		
t_{fall}	Fall Time	--	37	--		

Source-Drain Body Diode Characteristics

$T_J=25^{\circ}\text{C}$ unless otherwise specified

Symbol	Parameter	Min	Typ.	Max.	Unit	Test Conditions
I_{SD}	Continuous Source Current	--	--	120	A	Integral PN-diode in MOSFET
I_{SM}	Pulsed Source Current	--	--	480		
V_{SD}	Diode Forward Voltage	--	--	1.2	V	$I_S=30\text{A}$, $V_{GS}=0\text{V}$
trr	Reverse recovery time	--	30	--	ns	$V_{GS}=0\text{V}$, $I_F=30\text{A}$, $di_F/dt=100\text{A}/\mu\text{s}$
Qrr	Reverse recovery charge	--	5	--	nC	

Note:

-
- [1] $T_J=+25^{\circ}\text{C}$ to $+150^{\circ}\text{C}$.
 - [2] Silicon limited current only.
 - [3] Package limited current.
 - [4] Repetitive rating; pulse width limited by maximum junction temperature.
 - [5] Pulse width $\leq 380\mu\text{s}$; duty cycle $\leq 2\%$.

Typical Characteristics

Figure 1. Transient Thermal Impedance

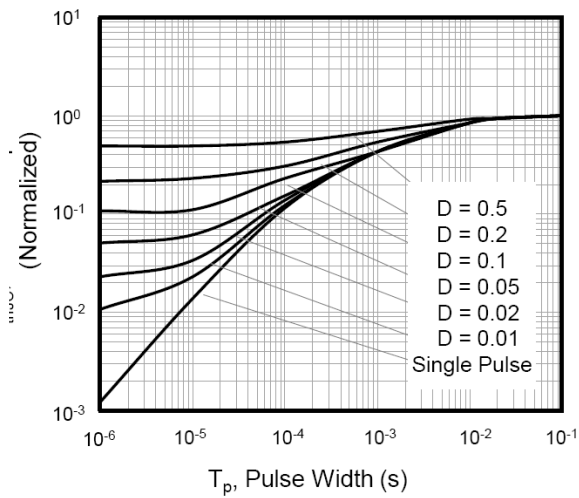

Figure 2. Output Characteristics

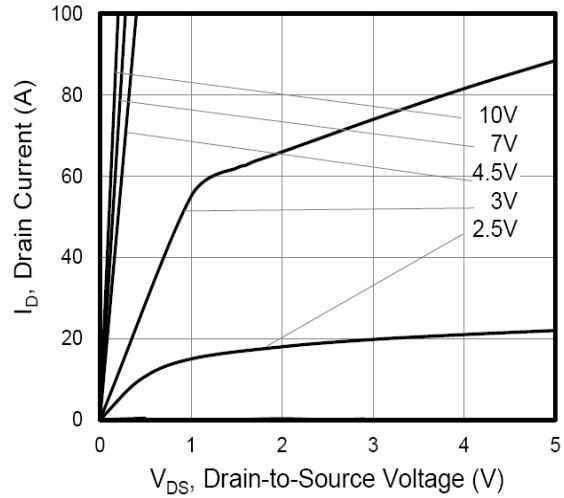

Figure 3. On-Resistance vs. Drain Current

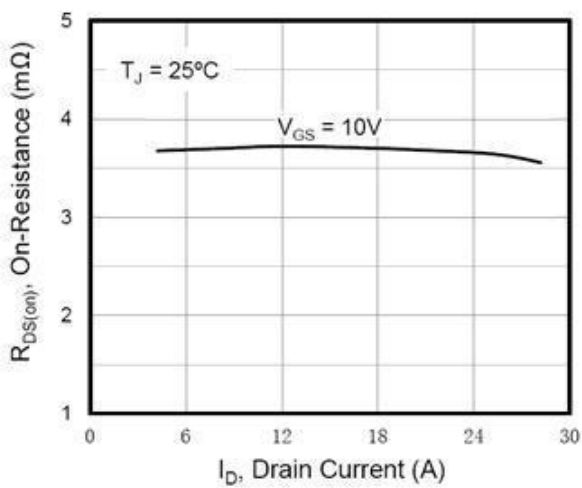

Figure 4. Capacitance

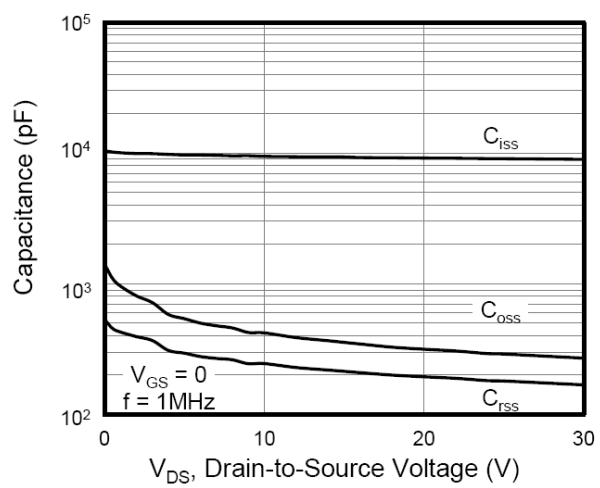

Figure 5. Gate Charge

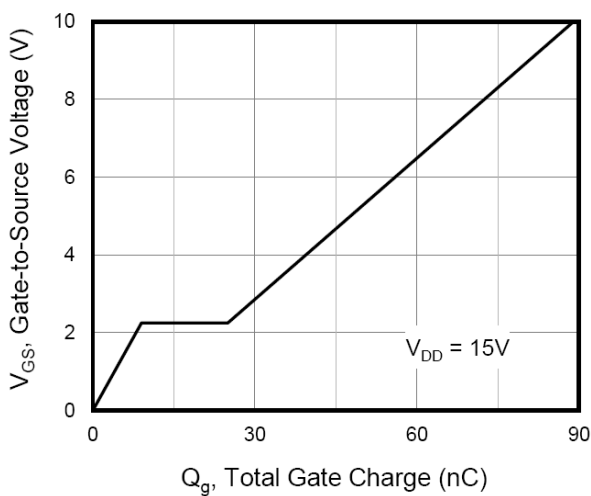
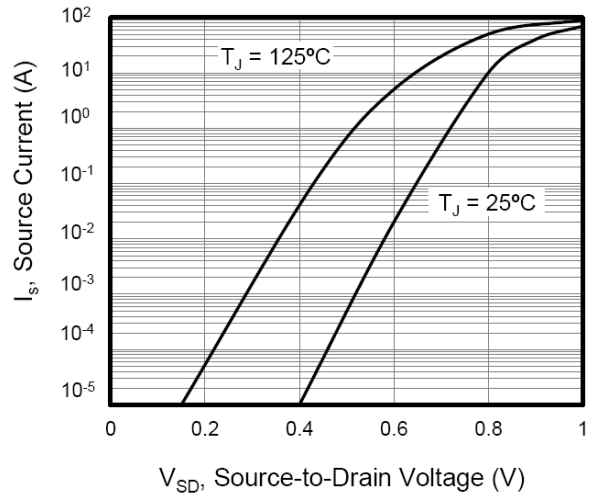
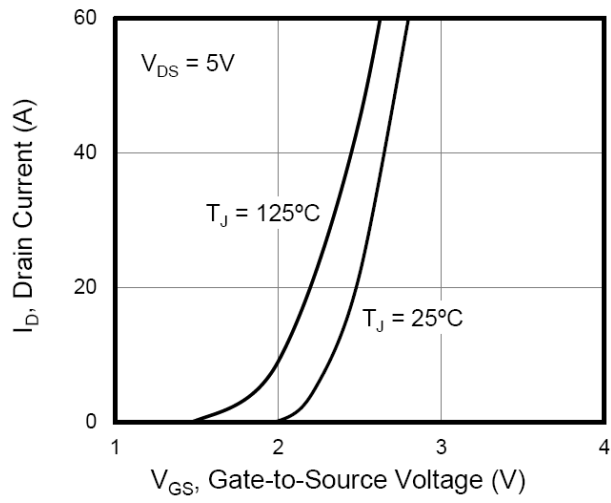

Figure 6. Body Diode Forward Voltage



Typical Characteristics

Figure 7 Transfer Characteristics



Test Circuits and Waveforms

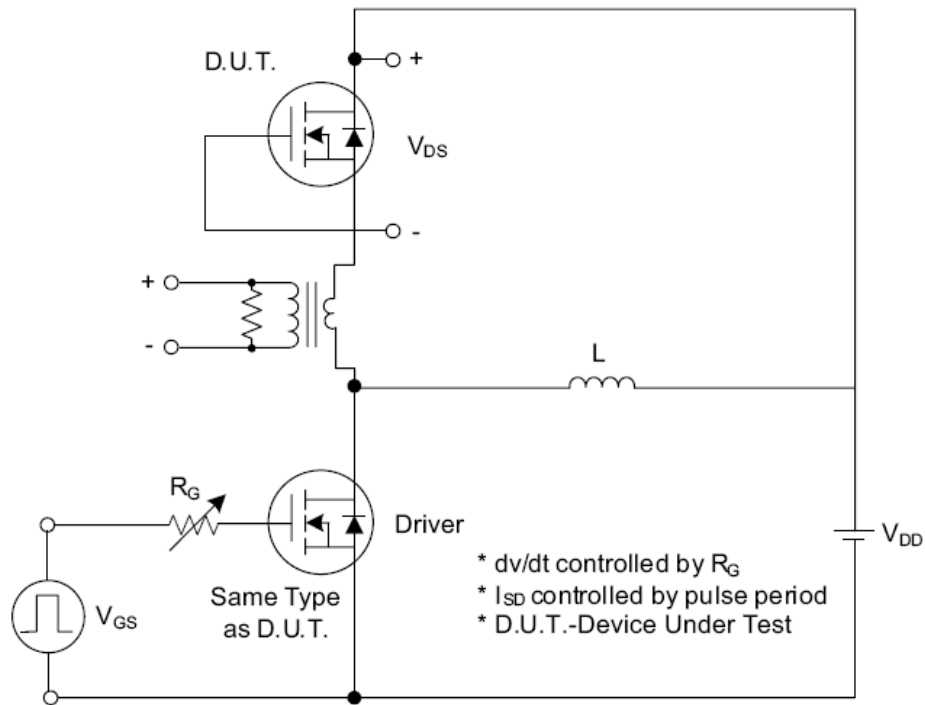

Fig. 1.1 Peak Diode Recovery dv/dt Test Circuit

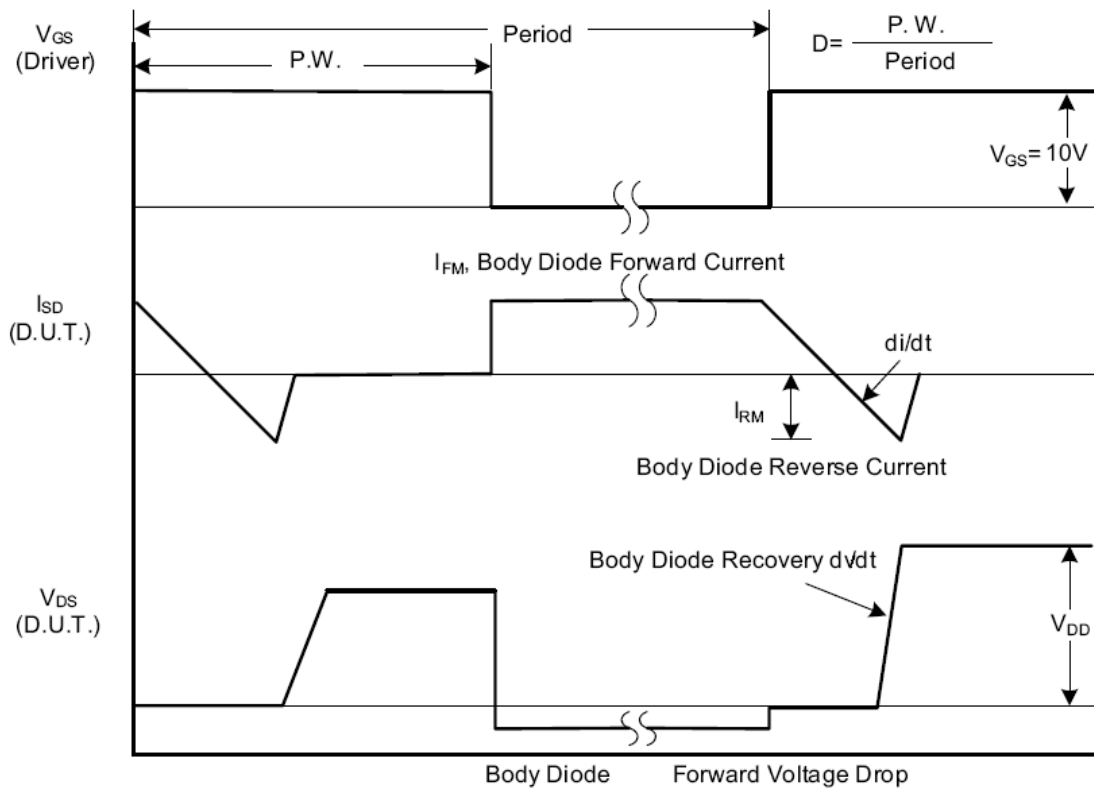

Fig. 1.2 Peak Diode Recovery dv/dt Waveforms

Test Circuits and Waveforms (Cont.)

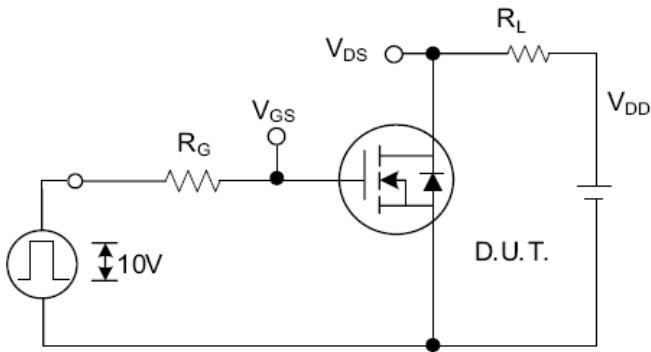

Fig. 2.1 Switching Test Circuit

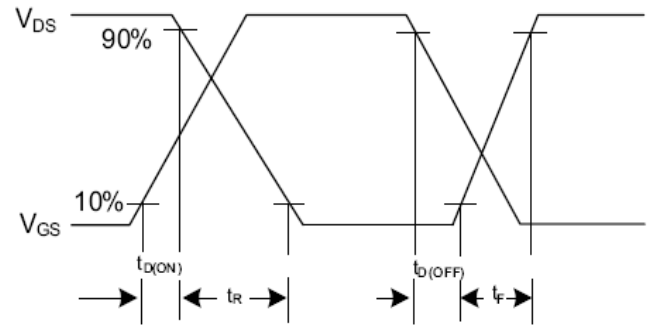

Fig. 2.2 Switching Waveforms

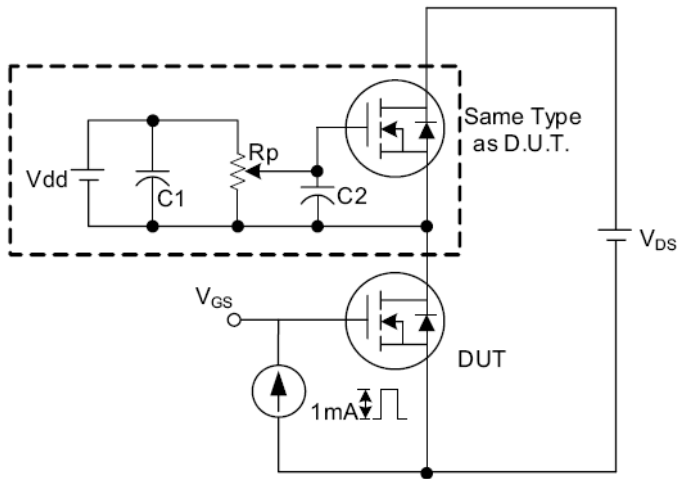

Fig. 3.1 Gate Charge Test Circuit

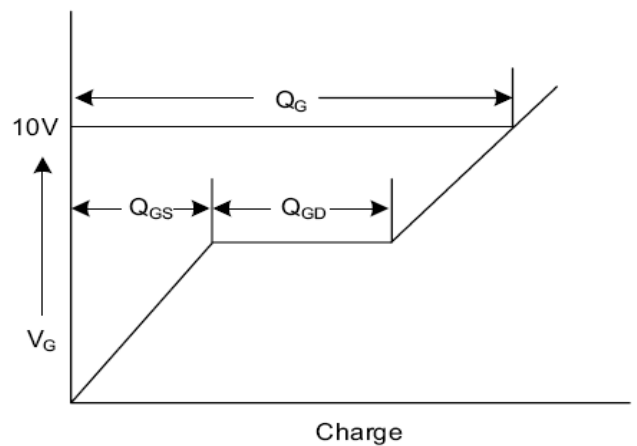

Fig. 3.2 Gate Charge Waveform

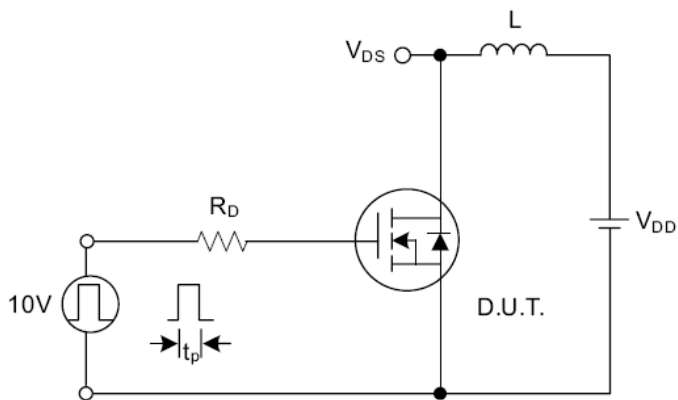

Fig. 4.1 Unclamped Inductive Switching Test Circuit

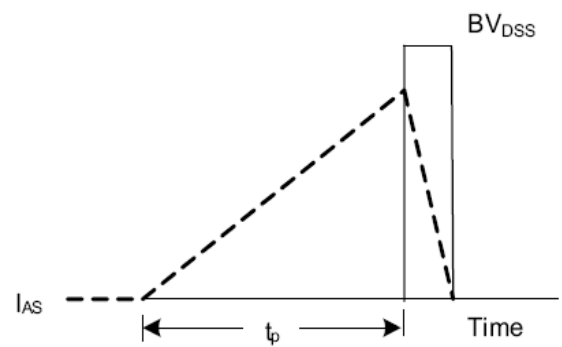

Fig. 4.2 Unclamped Inductive Switching Waveforms

X-ON Electronics

Largest Supplier of Electrical and Electronic Components

Click to view similar products for [MOSFET](#) category:

Click to view products by [Shikues](#) manufacturer:

Other Similar products are found below :

[IRFD120](#) [JANTX2N5237](#) [2SK2267\(Q\)](#) [BUK455-60A/B](#) [TK100A10N1,S4X\(S](#) [MIC4420CM-TR](#) [VN1206L](#) [NDP4060](#) [SI4482DY](#)
[IRS2092STRPBF-EL](#) [IPS70R2K0CEAKMA1](#) [TK31J60W5,S1VQ\(O](#) [TK31J60W,S1VQ\(O](#) [TK16J60W,S1VQ\(O](#) [2SK2614\(TE16L1,Q\)](#)
[DMN1017UCP3-7](#) [EFC2J004NUZTDG](#) [P85W28HP2F-7071](#) [DMN1053UCP4-7](#) [NTE2384](#) [DMC2700UDMQ-7](#) [DMN2080UCB4-7](#)
[DMN61D9UWQ-13](#) [US6M2GTR](#) [DMN31D5UDJ-7](#) [DMP22D4UFO-7B](#) [IPS60R3K4CEAKMA1](#) [DMN1006UCA6-7](#) [DMN16M9UCA6-7](#)
[STF5N65M6](#) [IRF40H233XTMA1](#) [STU5N65M6](#) [DMN6022SSD-13](#) [DMN13M9UCA6-7](#) [DMTH10H4M6SPS-13](#) [IPS60R360PFD7SAKMA1](#)
[DMN2990UFB-7B](#) [SSM3K35CT,L3F](#) [IPLK60R1K0PFD7ATMA1](#) [2N7002W-G](#) [MCAC30N06Y-TP](#) [IPWS65R035CFD7AXKSA1](#)
[MCQ7328-TP](#) [SSM3J143TU,LXHF](#) [DMN12M3UCA6-7](#) [PJMF280N65E1_T0_00201](#) [PJMF380N65E1_T0_00201](#)
[PJMF280N60E1_T0_00201](#) [PJMF600N65E1_T0_00201](#) [PJMF900N65E1_T0_00201](#)