

650V N-ch Planar MOSFET

BV_{DSS}	$R_{DS(ON),typ.}$	I_D
650V	0.60Ω	12A

General Features

- RoHS Compliant
- $R_{DS(ON),typ.}=0.60\ \Omega@V_{GS}=10V$
- Low Gate Charge Minimize Switching Loss
- Fast Recovery Body Diode

Applications

- Adaptor
- Charger
- SMPS Standby Power

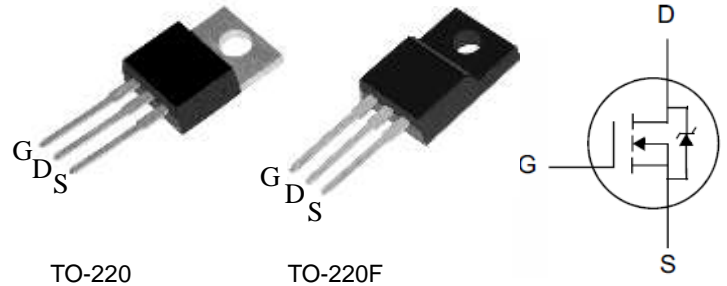

Ordering Information

Package No to Scale

PART NUMBE	SK12N65B-T	SK12N65B-TF
PACKAGE	TO-220	TO-220F

Absolute Maximum Ratings

$T_C=25^\circ\text{C}$ unless otherwise specified

Symbol	Parameter	SK12N65B-T	SK12N65B-TF	Unit
V_{DSS}	Drain-to-Source Voltage	650		V
V_{GSS}	Gate-to-Source Voltage	±30		
I_D	Continuous Drain Current	12		A
I_{DM}	Pulsed Drain Current at $V_{GS}=10V$	48		
E_{AS}	Single Pulse Avalanche Energy	450		mJ
P_D	Power Dissipation	125	73	W
	Derating Factor above 25°C	1.0	0.58	W/°C
T_L	Soldering Temperature Distance of 1.6mm from case for 10 seconds	300		°C
T_J & T_{STG}	Operating and Storage Temperature Range	-55 to 150		

Caution: Stresses greater than those listed in the "Absolute Maximum Ratings" may cause permanent damage to the device.

Thermal Characteristics

Symbol	Parameter	SK12N65B-T	SK12N65B-TF	Unit
$R_{\theta JC}$	Thermal Resistance, Junction-to-Case	1.0	1.71	°C/W
$R_{\theta JA}$	Thermal Resistance, Junction-to-Ambient	62	100	

Electrical Characteristics

OFF Characteristics

$T_J = 25^\circ\text{C}$ unless otherwise specified

Symbol	Parameter	Min.	Typ.	Max.	Unit	Test Conditions
BV_{DSS}	Drain-to-Source Breakdown Voltage	650	--	--	V	$V_{GS}=0V, I_D=250\mu A$
I_{DSS}	Drain-to-Source Leakage Current	--	--	1	uA	$V_{DS}=650V, V_{GS}=0V$
		--	--	100		$V_{DS}=520V, V_{GS}=0V, T_J=125^\circ\text{C}$
I_{GSS}	Gate-to-Source Leakage Current	--	--	+100	nA	$V_{GS}=+30V, V_{DS}=0V$
		--	--	-100		$V_{GS}=-30V, V_{DS}=0V$

ON Characteristics

$T_J = 25^\circ\text{C}$ unless otherwise specified

Symbol	Parameter	Min.	Typ.	Max.	Unit	Test Conditions
$R_{DS(ON)}$	Static Drain-to-Source On-Resistance	--	0.60	0.75	Ω	$V_{GS}=10V, I_D=6.0A$
$V_{GS(TH)}$	Gate Threshold Voltage	2.0	--	4.0	V	$V_{DS}=V_{GS}, I_D=250\mu A$
gfs	Forward Transconductance	--	5.2	--	S	$V_{DS}=15V, I_D=6.0A$

Dynamic Characteristics

Essentially independent of operating temperature

Symbol	Parameter	Min.	Typ.	Max.	Unit	Test Conditions
C_{iss}	Input Capacitance	--	1900	--	pF	$V_{GS}=0V, V_{DS}=25V, f=1.0\text{MHz}$
C_{rSS}	Reverse Transfer Capacitance	--	33	--		
C_{oss}	Output Capacitance	--	150	--		
Q_g	Total Gate Charge	--	52	--	nC	$V_{DD}=480V, I_D=12A, V_{GS}=0 \text{ to } 10V$
Q_{gs}	Gate-to-Source Charge	--	9	--		
Q_{gd}	Gate-to-Drain (Miller) Charge	--	20	--		

Resistive Switching Characteristics

Essentially independent of operating temperature

Symbol	Parameter	Min.	Typ.	Max.	Unit	Test Conditions
$t_{d(ON)}$	Turn-on Delay Time	--	25	--	nS	$V_{DD}=300V, I_D=12A, V_{GS}=10V, R_g=25\Omega$
t_{rise}	Rise Time	--	40	--		
$t_{d(OFF)}$	Turn-Off Delay Time	--	150	--		
t_{fall}	Fall Time	--	60	--		

Source-Drain Body Diode Characteristics $T_J=25^\circ\text{C}$ unless otherwise specified

Symbol	Parameter	Min	Typ.	Max.	Unit	Test Conditions
I_{SD}	Continuous Source Current ^[2]	--	--	12	A	Integral pn-diode in MOSFET
I_{SM}	Pulsed Source Current ^[2]	--	--	48		
V_{SD}	Diode Forward Voltage	--	--	1.4	V	$I_S=12\text{A}$, $V_{GS}=0\text{V}$
t_{rr}	Reverse Recovery Time	--	420	--	ns	$V_{GS}=0\text{V}$ $I_F=I_S$, $di/dt=100\text{A}/\mu\text{s}$
Q_{rr}	Reverse Recovery Charge	--	6.0	--	μC	

Note:

[1] $T_J=+25^\circ\text{C}$ to $+150^\circ\text{C}$

[2] Pulse width $\leq 380\mu\text{s}$; duty cycle $\leq 2\%$.

Typical Characteristics

Figure 1. Output Characteristics ($T_J = 25^\circ\text{C}$)

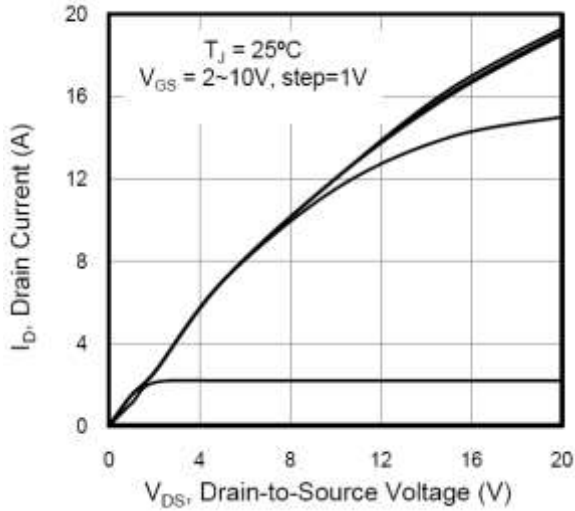

Figure 2. On-Resistance vs. Drain Current

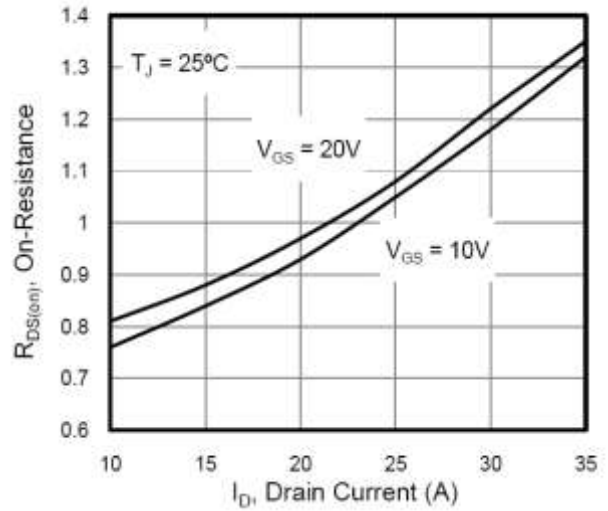

Figure 3. BV_{DSS} vs. Temperature

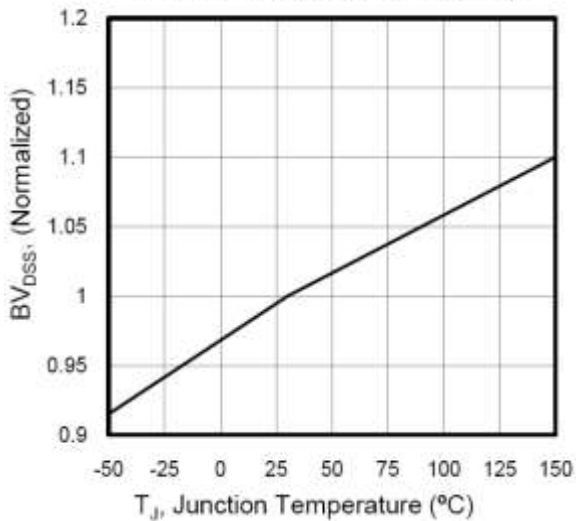

Figure 4. On-Resistance vs. Temperature

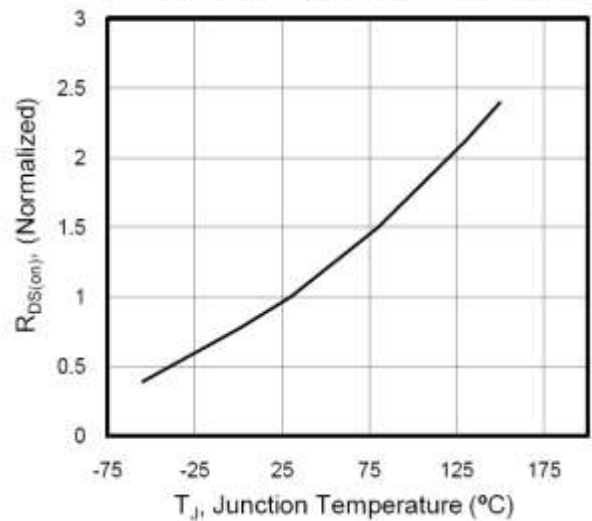

Figure 5. Gate Charge

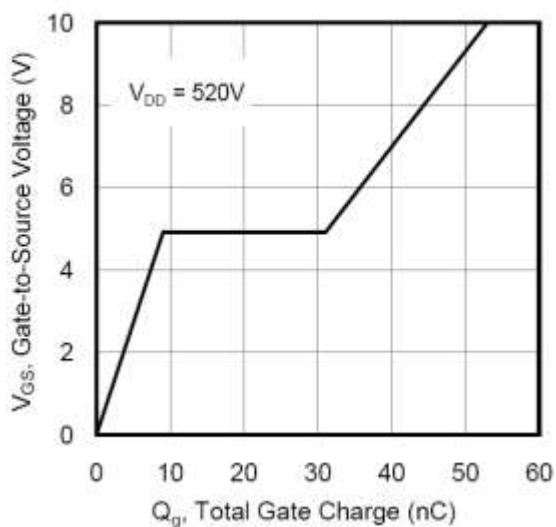
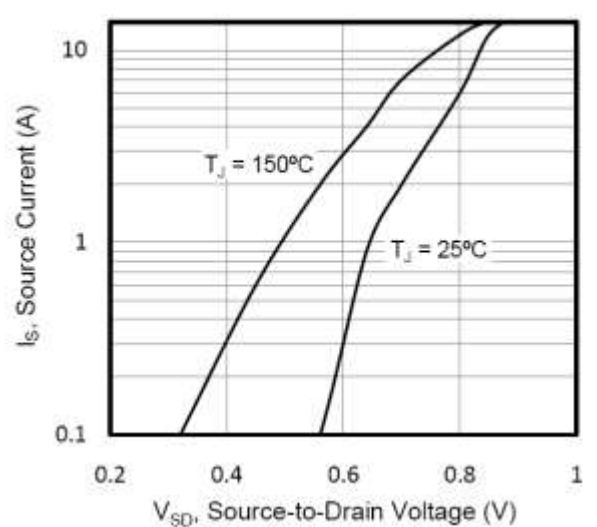

Figure 6. Body Diode Forward Voltage



Typical Characteristics

Figure 7. Safe Operating Area

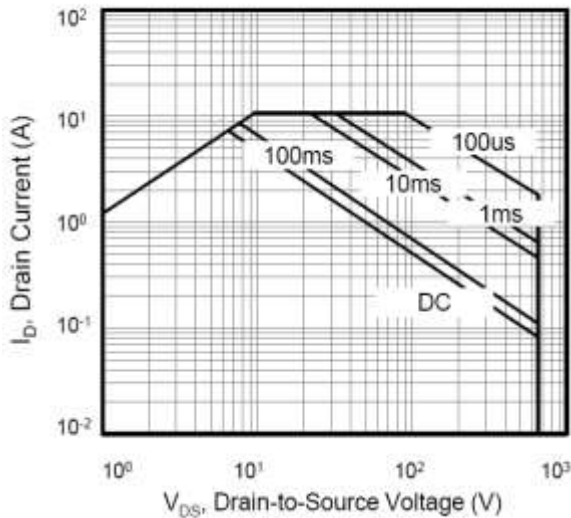

Figure 8. Transient Thermal Impedance

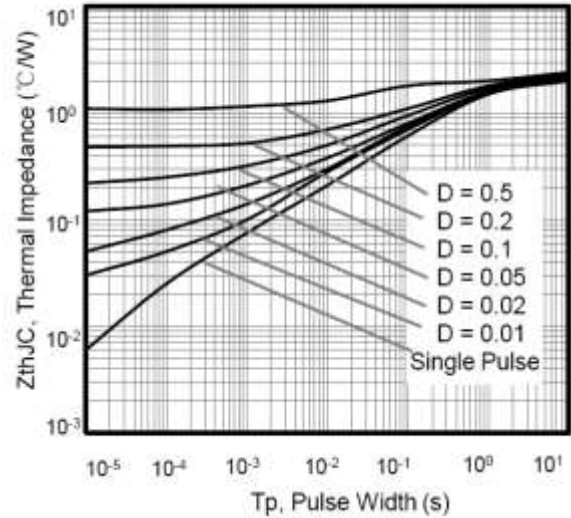

Figure 9. Maximum Continuous Drain Current vs T_c

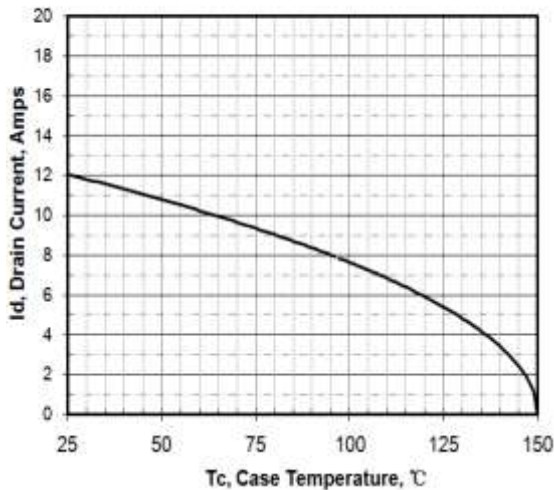

Figure 10. Max. Power Dissipation vs T_c

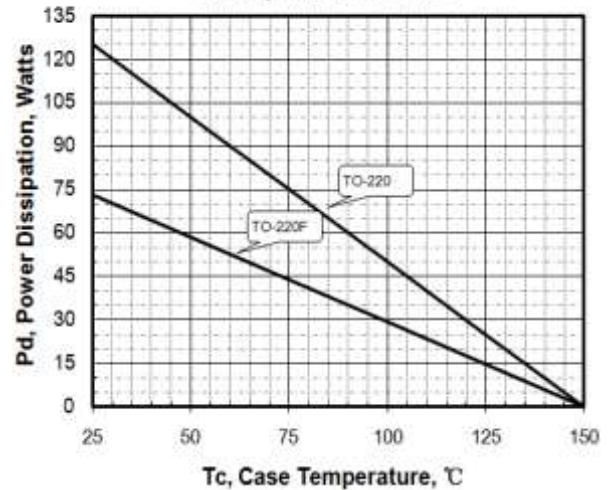
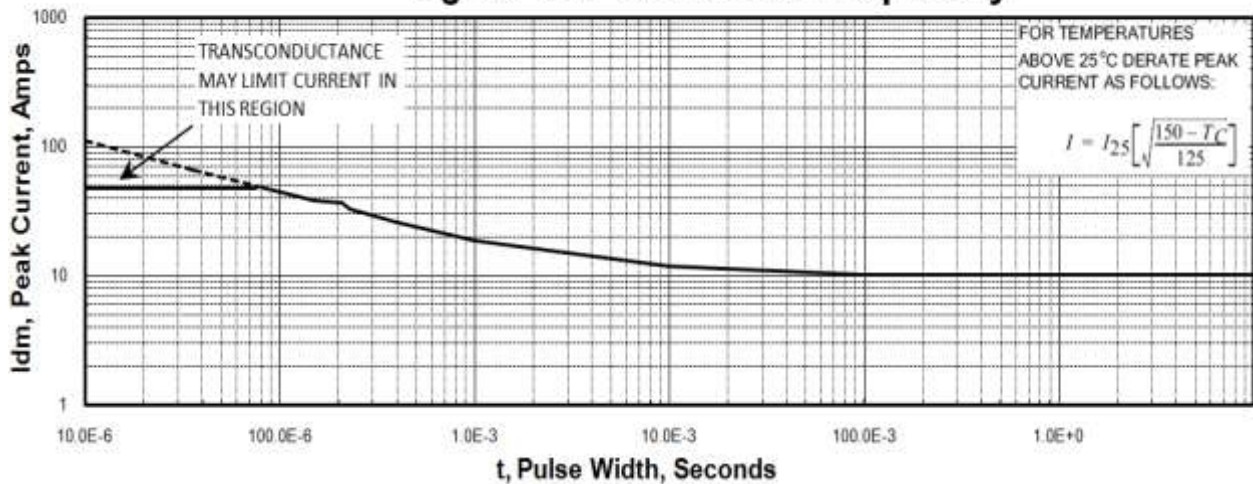

Figure 11. Peak Current Capability



Test Circuits and Waveforms

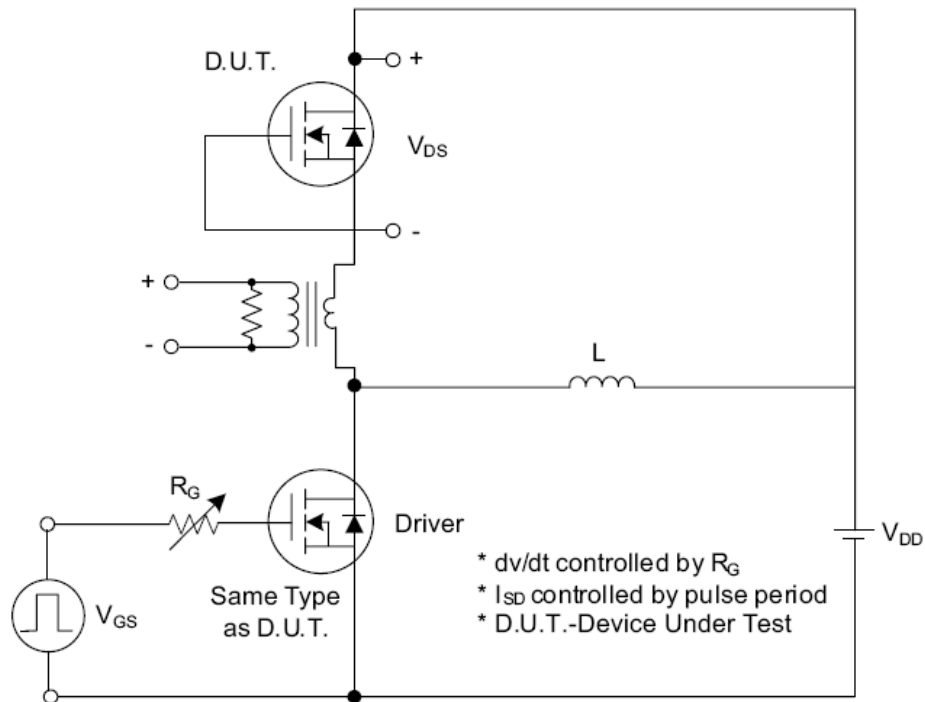

Fig. 1.1 Peak Diode Recovery dv/dt Test Circuit

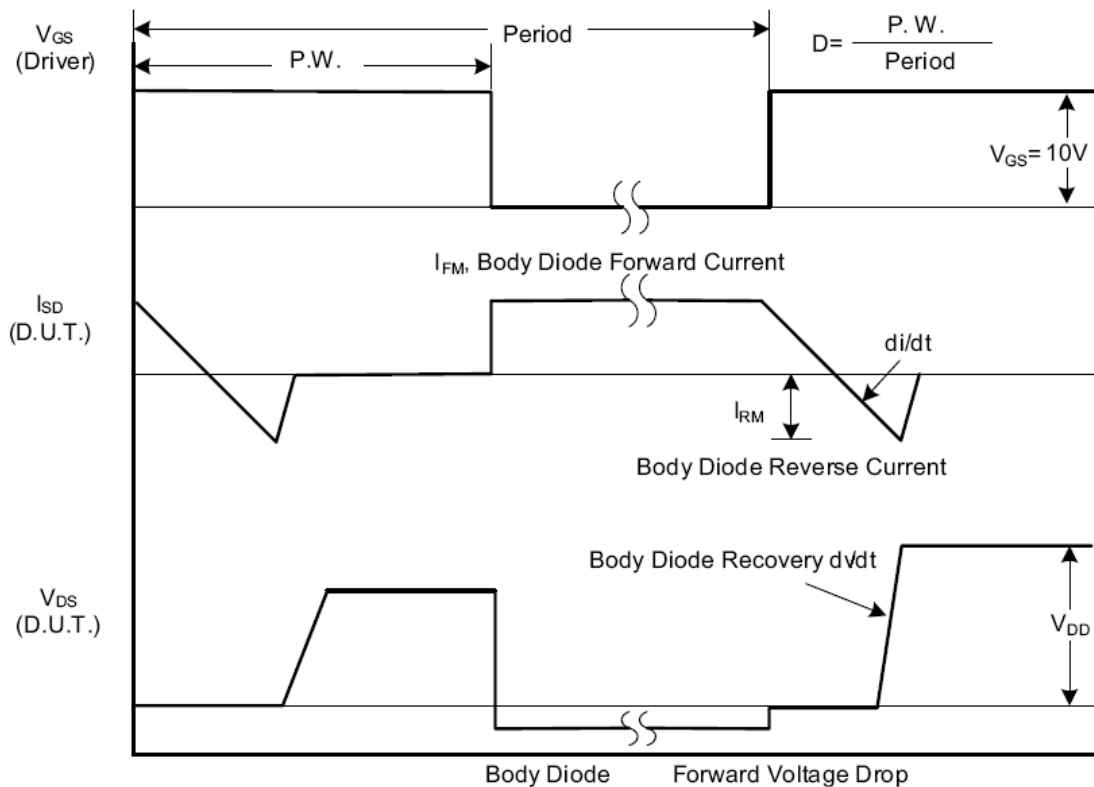

Fig. 1.2 Peak Diode Recovery dv/dt Waveforms

Test Circuits and Waveforms (Cont.)

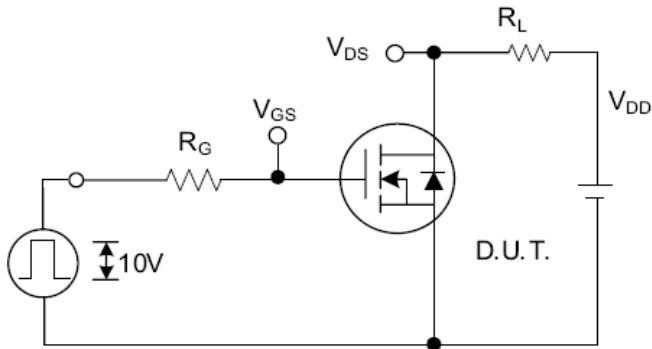

Fig. 2.1 Switching Test Circuit

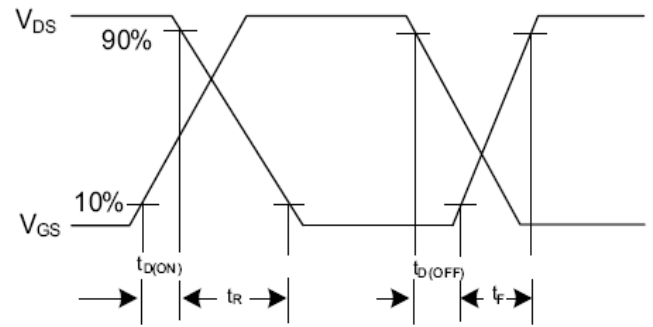

Fig. 2.2 Switching Waveforms

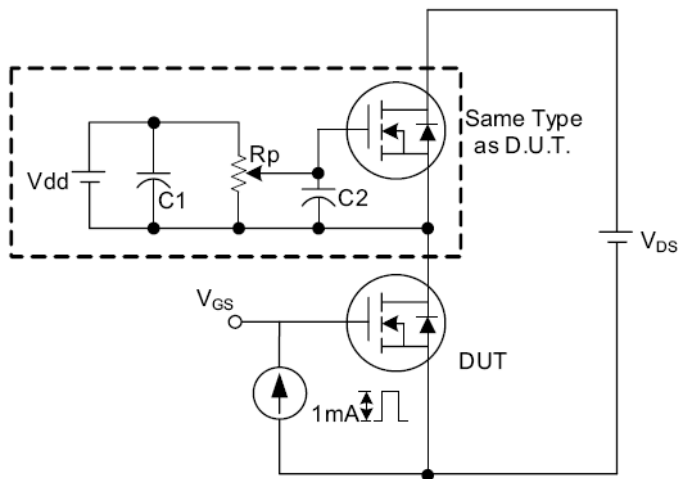

Fig. 3.1 Gate Charge Test Circuit

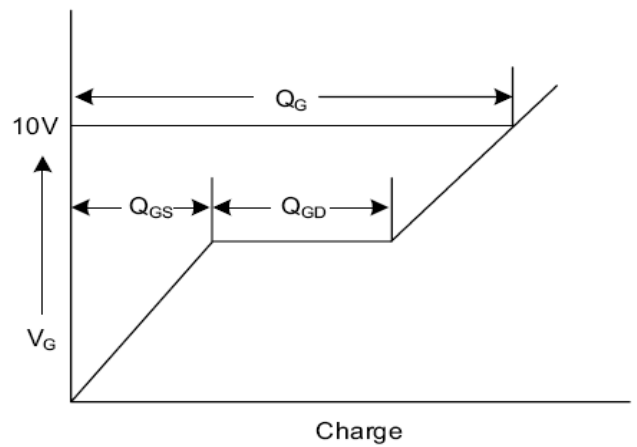

Fig. 3.2 Gate Charge Waveform

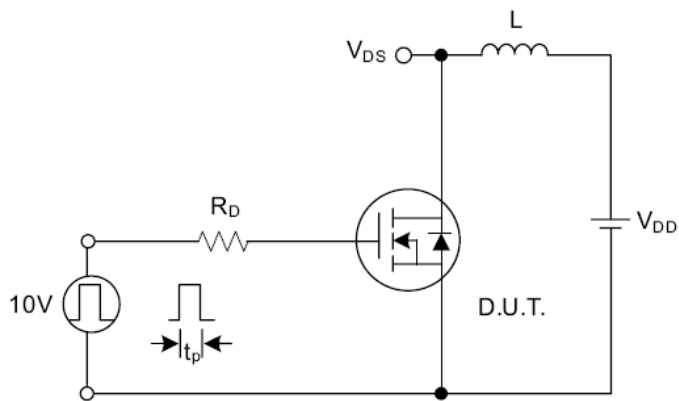

Fig. 4.1 Unclamped Inductive Switching Test Circuit

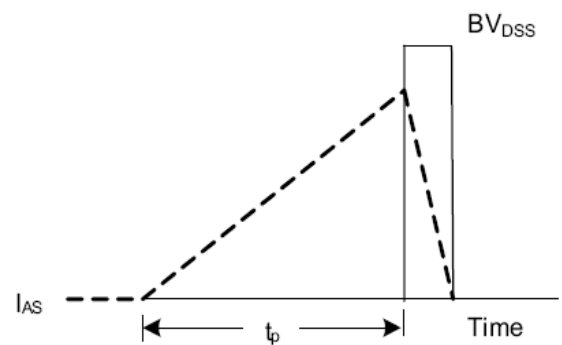
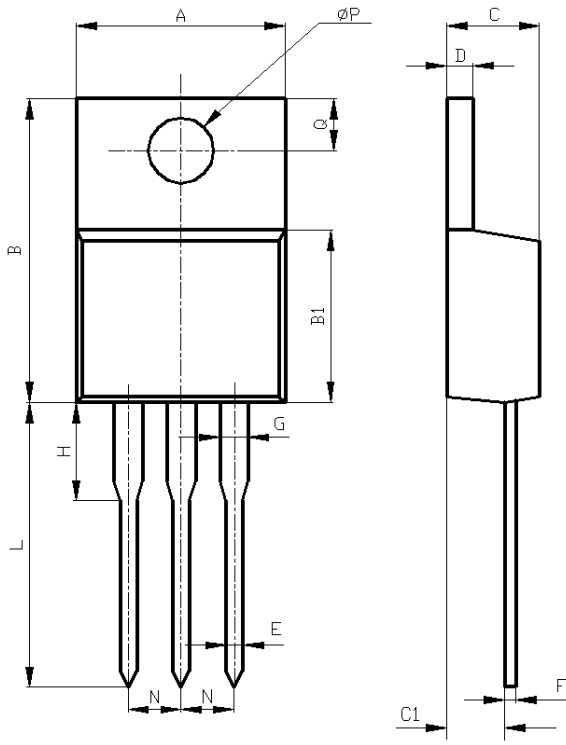

Fig. 4.2 Unclamped Inductive Switching Waveforms

PACKAGE OUTLINE

TO-220



: mm

	Unit (mm)	
	MIN	MAX
A	10.1	10.5
B	15.2	15.6
B1	9.00	9.40
C	4.40	4.60
C1	2.40	3.00
D	1.20	1.40
E	0.70	0.90
F	0.40	0.60
G	1.17	1.37
H	3.30	3.80
L	13.1	13.7
N	2.34	2.74
Q	2.40	3.00
ϕP	3.70	3.90

PACKAGE OUTLINE

TO-220F

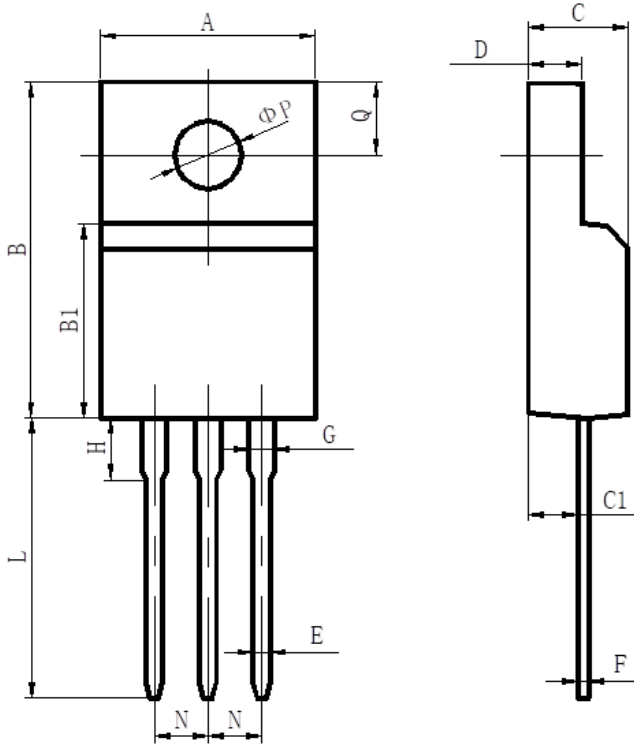

	Unit (mm)	
	MIN	MAX
A	9.70	10.30
B	15.50	16.10
B1	8.99	9.39
C	4.40	4.80
C1	2.15	2.55
D	2.50	2.90
E	0.70	0.90
F	0.40	0.60
G	1.12	1.42
H	3.40	3.80
L	12.6	13.6
N	2.34	2.74
Q	3.15	3.55
ϕP	3.00	3.30

X-ON Electronics

Largest Supplier of Electrical and Electronic Components

Click to view similar products for [MOSFET](#) category:

Click to view products by [Shikues](#) manufacturer:

Other Similar products are found below :

[IRFD120](#) [JANTX2N5237](#) [BUK455-60A/B](#) [MIC4420CM-TR](#) [VN1206L](#) [NDP4060](#) [SI4482DY](#) [IPS70R2K0CEAKMA1](#) [SQD23N06-31L-GE3](#)
[TK16J60W,S1VQ\(O](#) [2SK2614\(TE16L1,Q\)](#) [DMN1017UCP3-7](#) [DMN1053UCP4-7](#) [SQJ469EP-T1-GE3](#) [NTE2384](#) [DMC2700UDMQ-7](#)
[DMN2080UCB4-7](#) [DMN61D9UWQ-13](#) [US6M2GTR](#) [DMN31D5UDJ-7](#) [DMP22D4UFO-7B](#) [DMN1006UCA6-7](#) [DMN16M9UCA6-7](#)
[STF5N65M6](#) [IRF40H233XTMA1](#) [STU5N65M6](#) [DMN6022SSD-13](#) [DMN13M9UCA6-7](#) [DMTH10H4M6SPS-13](#) [DMN2990UFB-7B](#)
[IPB80P04P405ATMA2](#) [2N7002W-G](#) [MCAC30N06Y-TP](#) [MCQ7328-TP](#) [NTMC083NP10M5L](#) [BXP7N65D](#) [BXP4N65F](#) [AOL1454G](#)
[WMJ80N60C4](#) [BXP2N20L](#) [BXP2N65D](#) [BXT1150N10J](#) [BXT1700P06M](#) [TSM60NB380CP](#) [ROG](#) [RQ7L055BGTGR](#) [DMNH15H110SK3-13](#)
[SLF10N65ABV2](#) [BSO203SP](#) [BSO211P](#) [IPA60R230P6](#)