

P-Channel Enhancement Mode MOSFET

Feature

- -30V/-4.1A, $R_{DS(ON)} = 80\text{m}\Omega(\text{MAX}) @V_{GS} = -10\text{V}$.
 $R_{DS(ON)} = 100\text{m}\Omega(\text{MAX}) @V_{GS} = -4.5\text{V}$.
- Super High dense cell design for extremely low $R_{DS(ON)}$
- Reliable and Rugged
- SC-59 for Surface Mount Package



SOT-59

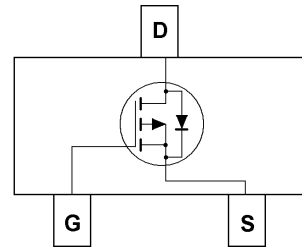

Applications

- Power Management
Portable Equipment and Battery Powered Systems.

Absolute Maximum Ratings $T_A=25^\circ\text{C}$ Unless Otherwise noted

Parameter	Symbol	Limit	Units
Drain-Source Voltage	V_{DS}	-30	V
Gate-Source Voltage	V_{GS}	± 20	V
Drain Current-Continuous	I_D	-4.1	A

Electrical Characteristics $T_A=25^\circ\text{C}$ Unless Otherwise noted

Parameter	Symbol	Test Conditions	Min	Typ.	Max	Units
Off Characteristics						
Drain to Source Breakdown Voltage	BVDSS	$V_{GS}=0\text{V}, I_D=-250\mu\text{A}$	-30	-	-	V
Zero-Gate Voltage Drain Current	IDSS	$V_{DS}=-30\text{V}, V_{GS}=0\text{V}$	-	-	-1	μA
Gate Body Leakage Current, Forward	IGSSF	$V_{GS}=20\text{V}, V_{DS}=0\text{V}$	-	-	100	nA
Gate Body Leakage Current, Reverse	IGSSR	$V_{GS}=-20\text{V}, V_{DS}=0\text{V}$	-	-	-100	nA
On Characteristics						
Gate Threshold Voltage	$V_{GS(th)}$	$V_{GS}=V_{DS}, I_D=-250\mu\text{A}$	-1.0	-	-3.0	V
Static Drain-source On-Resistance	RDS(ON)	$V_{GS}=-10\text{V}, I_D=-4.1\text{A}$	-	65	80	$\text{m}\Omega$
		$V_{GS}=-4.5\text{V}, I_D=-4.0\text{A}$	-	85	100	$\text{m}\Omega$
Drain-Source Diode Characteristics and Maximum Ratings						
Drain-Source Diode Forward Voltage	VSD	$V_{GS}=0\text{V}, I_S=-1.0\text{A}$			-1.2	V



Typical Characteristics

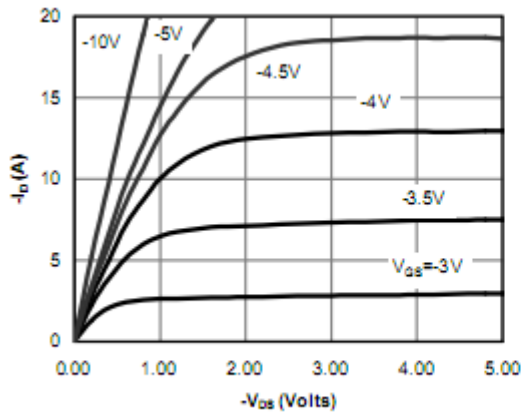

Figure 1: On-Region Characteristics

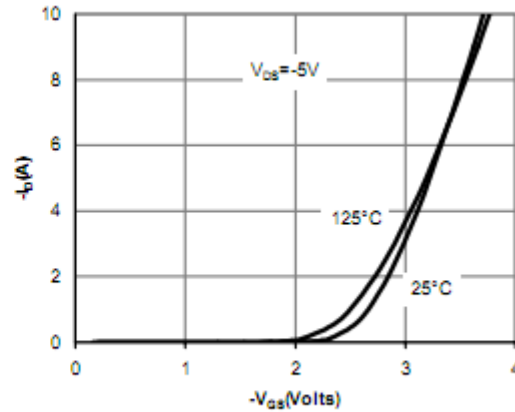

Figure 2: Transfer Characteristics

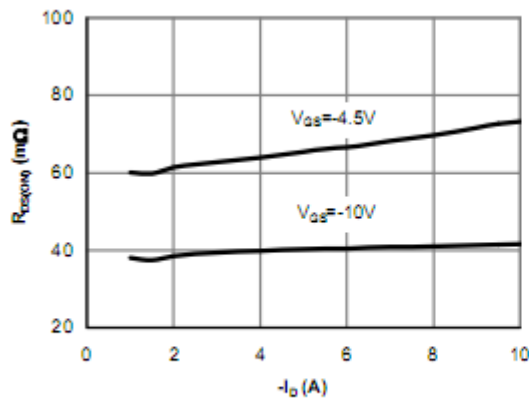

Figure 3: On-Resistance vs. Drain Current and Gate Voltage

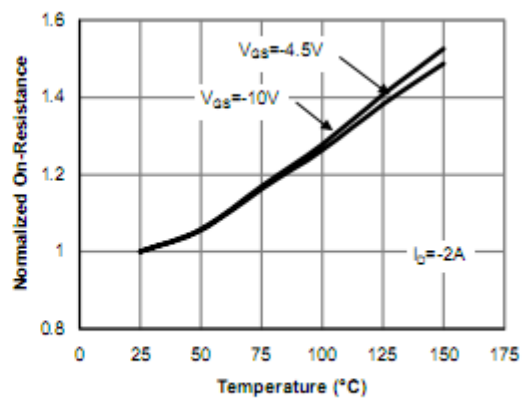

Figure 4: On-Resistance vs. Junction Temperature

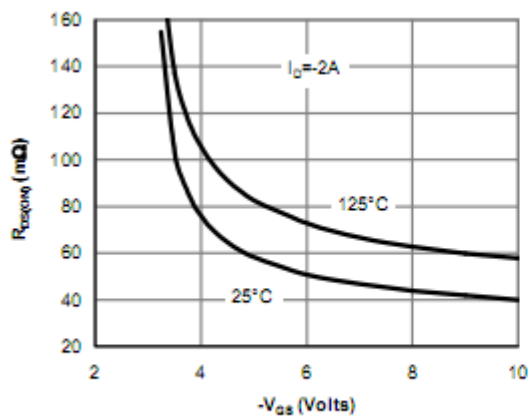

Figure 5: On-Resistance vs. Gate-Source Voltage

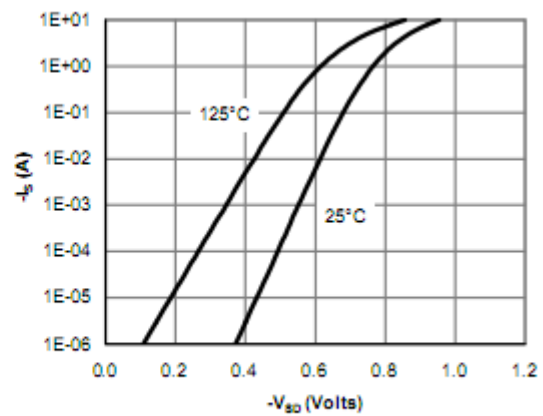

Figure 6: Body-Diode Characteristics



Typical Characteristics

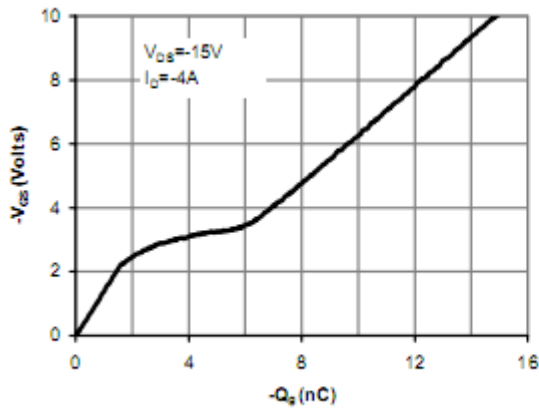

Figure 7: Gate-Charge Characteristics

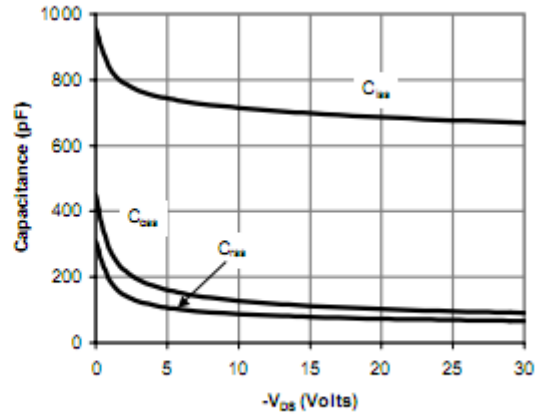

Figure 8: Capacitance Characteristics

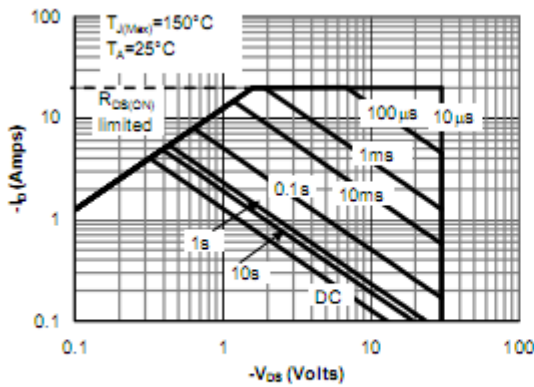

Figure 9: Maximum Forward Biased Safe Operating Area (Note E)

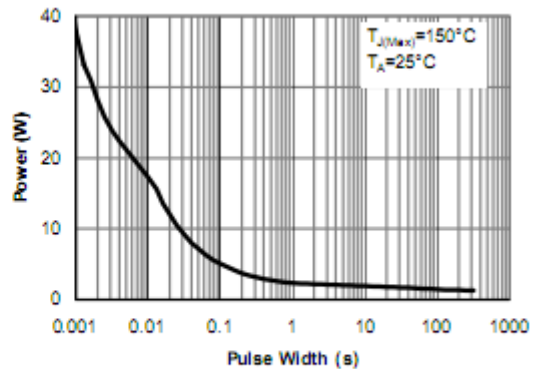

Figure 10: Single Pulse Power Rating Junction-to-Ambient (Note E)

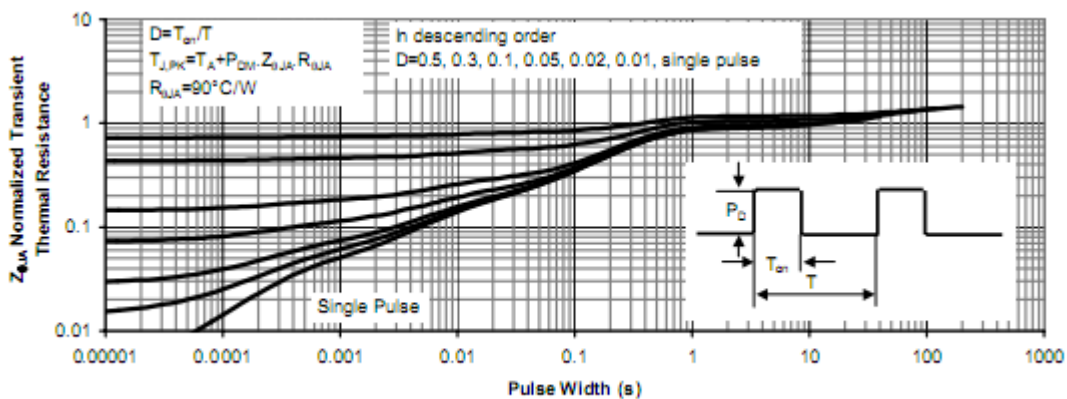

Figure 11: Normalized Maximum Transient Thermal Impedance

SHIKE MAKE CONSCIOUS PRODUCT
CONSCIOUS PRODUCTS BEGIN WITH CONSCIOUS PEOPLE



Package Outline Dimensions (UNIT: mm)

SC-59

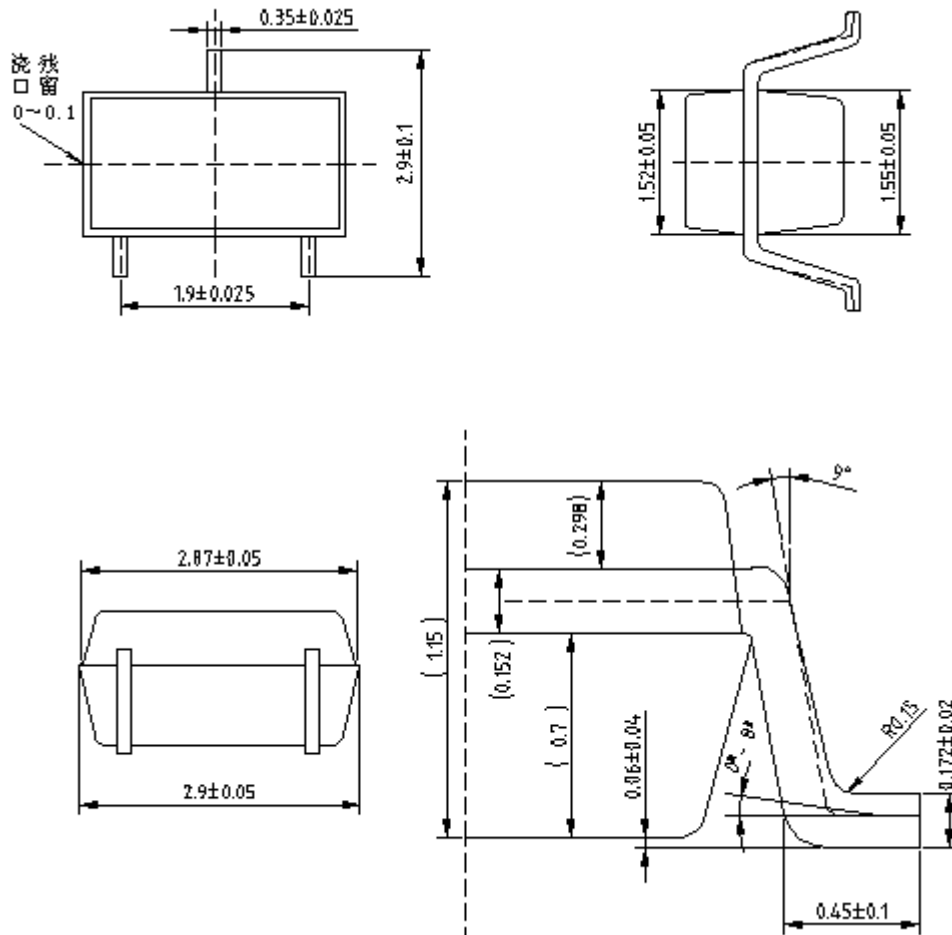

X-ON Electronics

Largest Supplier of Electrical and Electronic Components

Click to view similar products for [MOSFET](#) category:

Click to view products by [Shikues](#) manufacturer:

Other Similar products are found below :

[614233C](#) [648584F](#) [FDPF9N50NZ](#) [IRFD120](#) [IRFF430](#) [JANTX2N5237](#) [2N7000](#) [FCA20N60_F109](#) [FDZ595PZ](#) [2SK2267\(Q\)](#) [2SK2545\(Q,T\)](#)
[405094E](#) [423220D](#) [MIC4420CM-TR](#) [VN1206L](#) [614234A](#) [715780A](#) [SSM6J414TU,LF\(T](#) [751625C](#) [PSMN4R2-30MLD](#)
[TK31J60W5,S1VQ\(O](#) [2SK2614\(TE16L1,Q\)](#) [DMN1017UCP3-7](#) [EFC2J004NUZTDG](#) [FCAB21350L1](#) [P85W28HP2F-7071](#) [DMN1053UCP4-7](#)
[NTE2384](#) [NTE2969](#) [NTE6400A](#) [DMN61D9UWQ-13](#) [US6M2GTR](#) [DMN31D5UDJ-7](#) [SSM6P54TU,LF](#) [DMP22D4UFO-7B](#)
[IPS60R3K4CEAKMA1](#) [DMN1006UCA6-7](#) [DMN16M9UCA6-7](#) [STF5N65M6](#) [STU5N65M6](#) [C3M0021120D](#) [DMN13M9UCA6-7](#)
[BSS340NWH6327XTSA1](#) [MCM3400A-TP](#) [DMTH10H4M6SPS-13](#) [IPS60R1K0PFD7SAKMA1](#) [IPS60R360PFD7SAKMA1](#)
[IPS60R600PFD7SAKMA1](#) [IPS60R210PFD7SAKMA1](#) [DMN2990UFB-7B](#)