

60V N-Channel MOSFET

General Features

- Proprietary New Trench Technology
- $R_{DS(ON),typ.}=13.5\text{ m}\Omega@V_{GS}=10\text{V}$
- Low Gate Charge Minimize Switching Loss
- Fast Recovery Body Diode

Applications

- Automotive
- DC Motor Control
- Class D Amplifier

BV_{DSS}	$R_{DS(ON),typ.}$	I_D
60V	13.5m Ω	55A

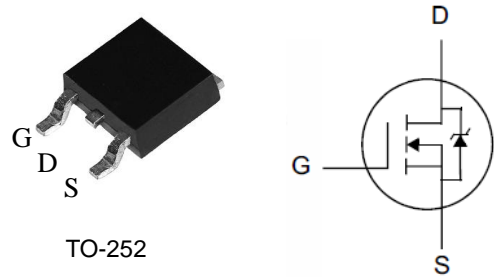

TO-252

Package No to Scale

Absolute Maximum Ratings

$T_C=25^\circ\text{C}$ unless otherwise specified

Symbol	Parameter	SK 50N06A	Unit
V_{DSS}	Drain-to-Source Voltage ^[1]	60	V
V_{GSS}	Gate-to-Source Voltage	± 20	
I_D	Continuous Drain Current	55	A
	Continuous Drain Current at $T_C=100^\circ\text{C}$	35	
I_{DM}	Pulsed Drain Current at $V_{GS}=10\text{V}^{[2]}$	200	
E_{AS}	Single Pulse Avalanche Energy	300	mJ
P_D	Power Dissipation	85	W
	Derating Factor above 25°C	0.57	W/ $^\circ\text{C}$
T_L T_{PAK}	Maximum Temperature for Soldering Leads at 0.063in (1.6mm) from Case for 10 seconds, Package Body for 10 seconds	300 260	$^\circ\text{C}$
T_J & T_{STG}	Operating and Storage Temperature Range	-55 to 175	

Caution: Stresses greater than those listed in the "Absolute Maximum Ratings" may cause permanent damage to the device.

Thermal Characteristics

Symbol	Parameter	SK 50N06A	Unit
$R_{\theta JC}$	Thermal Resistance, Junction-to-Case	1.76	$^\circ\text{C/W}$
$R_{\theta JA}$	Thermal Resistance, Junction-to-Ambient	75	

Electrical Characteristics

OFF Characteristics $T_J = 25^\circ\text{C}$ unless otherwise specified

Symbol	Parameter	Min.	Typ.	Max.	Unit	Test Conditions
BV_{DSS}	Drain-to-Source Breakdown Voltage	60	--	--	V	$V_{GS}=0V, I_D=250\mu A$
I_{DSS}	Drain-to-Source Leakage Current	--	--	1	μA	$V_{DS}=60V, V_{GS}=0V$
		--	--	100		$V_{DS}=48V, V_{GS}=0V,$ $T_J=125^\circ\text{C}$
I_{GSS}	Gate-to-Source Leakage Current	--	--	+1.0	μA	$V_{GS}=+20V, V_{DS}=0V$
		--	--	-1.0		$V_{GS}=-20V, V_{DS}=0V$

ON Characteristics

 $T_J = 25^\circ\text{C}$ unless otherwise specified

Symbol	Parameter	Min.	Typ.	Max.	Unit	Test Conditions
$R_{DS(ON)}$	Static Drain-to-Source On-Resistance	--	13.5	17	$m\Omega$	$V_{GS}=10V, I_D=20A^{[3]}$
$V_{GS(TH)}$	Gate Threshold Voltage	1.0	--	3.0	V	$V_{DS}=V_{GS}, I_D=250\mu A$
gFS	Forward Transconductance	18	--	--	S	$V_{DS}=5V, I_D=20A$

Dynamic Characteristics

Essentially independent of operating temperature

Symbol	Parameter	Min.	Typ.	Max.	Unit	Test Conditions
C_{iss}	Input Capacitance	--	2.05	--	nF	$V_{GS}=0V,$ $V_{DS}=30V,$ $f=1.0MHz$
C_{rSS}	Reverse Transfer Capacitance	--	0.12	--		
C_{oss}	Output Capacitance	--	0.16	--		
Q_g	Total Gate Charge	--	50	--	nC	$V_{DD}=30V,$ $I_D=20A, V_{GS}=0$ to 10V
Q_{gs}	Gate-to-Source Charge	--	6.0	--		
Q_{gd}	Gate-to-Drain (Miller) Charge	--	15	--		

Resistive Switching Characteristics

Essentially independent of operating temperature

Symbol	Parameter	Min.	Typ.	Max.	Unit	Test Conditions
$t_{d(ON)}$	Turn-on Delay Time	--	7.5	--	nS	$V_{DD}=30V,$ $I_D=20A,$ $V_{GS}=10V$ $R_G=3.0\Omega$
t_{rise}	Rise Time	--	5.0	--		
$t_{d(OFF)}$	Turn-Off Delay Time	--	28	--		
t_{fall}	Fall Time	--	5.5	--		

Source- Drain Body Diode Characteristics T_J=25°C unless otherwise specified

Symbol	Parameter	Min	Typ.	Max.	Unit	Test Conditions
I _{SD}	Continuous Source Current ^[2]	--	--	55	A	Integral PN-diode in MOSFET
I _{SM}	Pulsed Source Current ^[2]	--	--	200		
V _{SD}	Diode Forward Voltage	--	--	1.5	V	I _S =55A ^[3] , V _{GS} =0V
trr	Reverse recovery time	--	30	--	ns	V _{GS} =0V, I _F =20A, di _F /dt=100A/μs
Qrr	Reverse recovery charge	--	40	--	nC	

Note:

[1] T_J=+25°C to +175°C .

[2] Repetitive rating; pulse width limited by maximum junction temperature.

[3] Pulse width≤380μs; duty cycle≤2%.

Typical Characteristics

Typical Electrical and Thermal Characteristics (Curves)

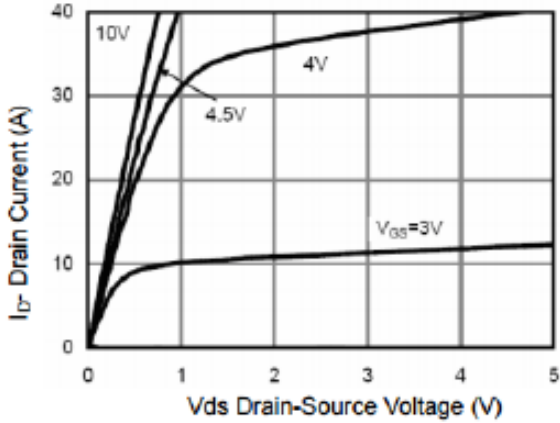

Figure 1 Output Characteristics

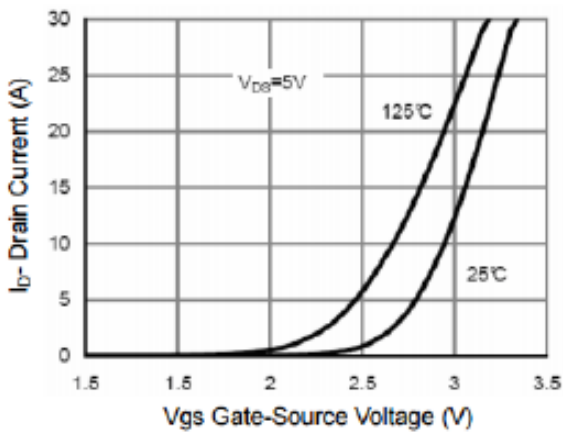

Figure 2 Transfer Characteristics

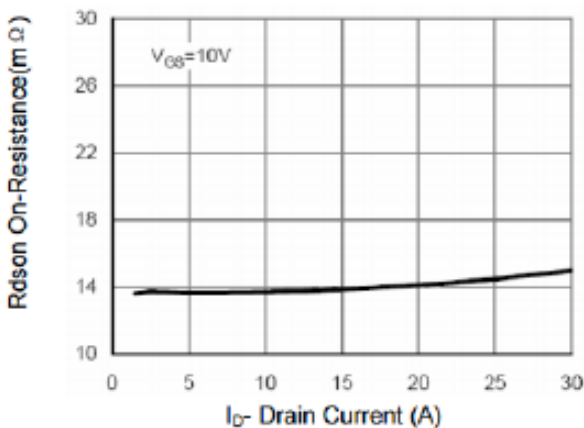

Figure 3 Rdson- Drain Current

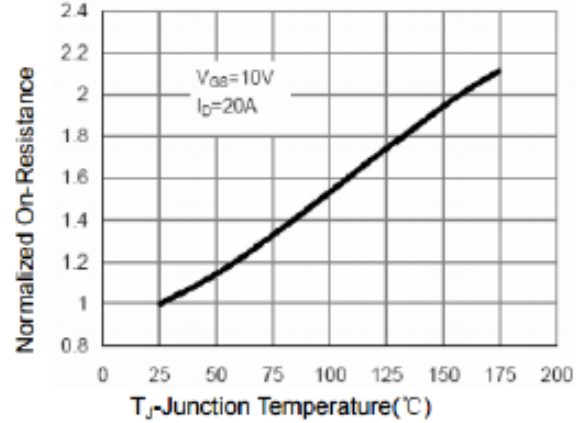

Figure 4 Rdson-Junction Temperature

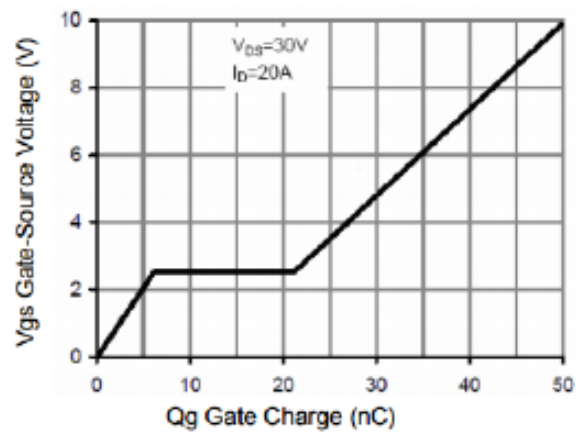

Figure 5 Gate Charge

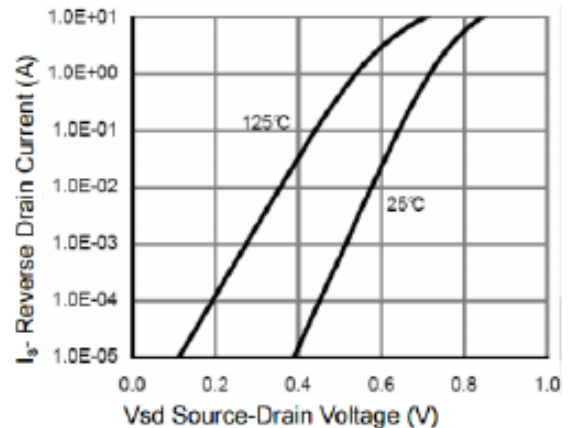

Figure 6 Source- Drain Diode Forward

Typical Characteristics(Cont.)

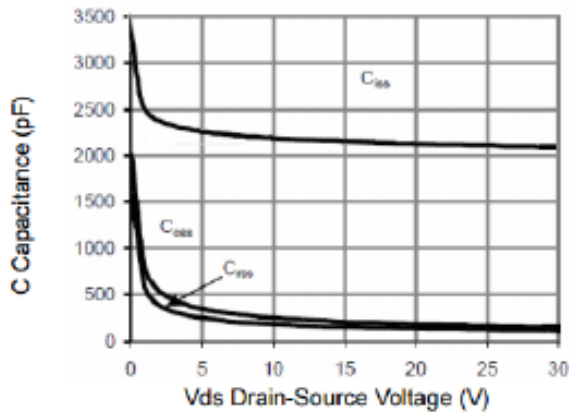

Figure 7 Capacitance vs Vds

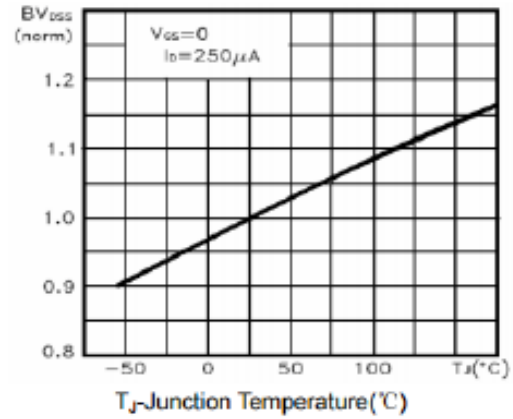

Figure 9 BV_{OSS} vs Junction Temperature

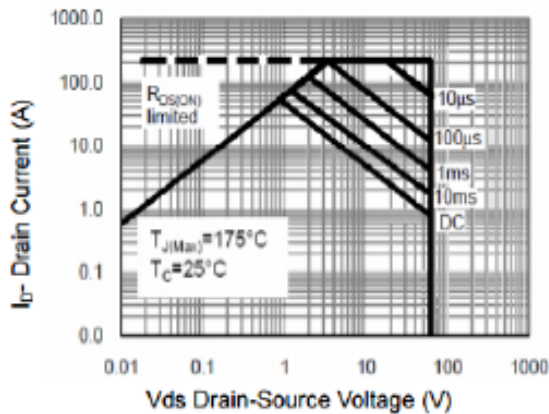

Figure 8 Safe Operation Area

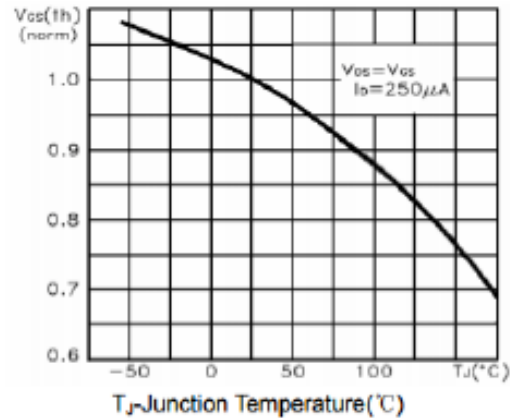

Figure 10 $V_{GS(th)}$ vs Junction Temperature

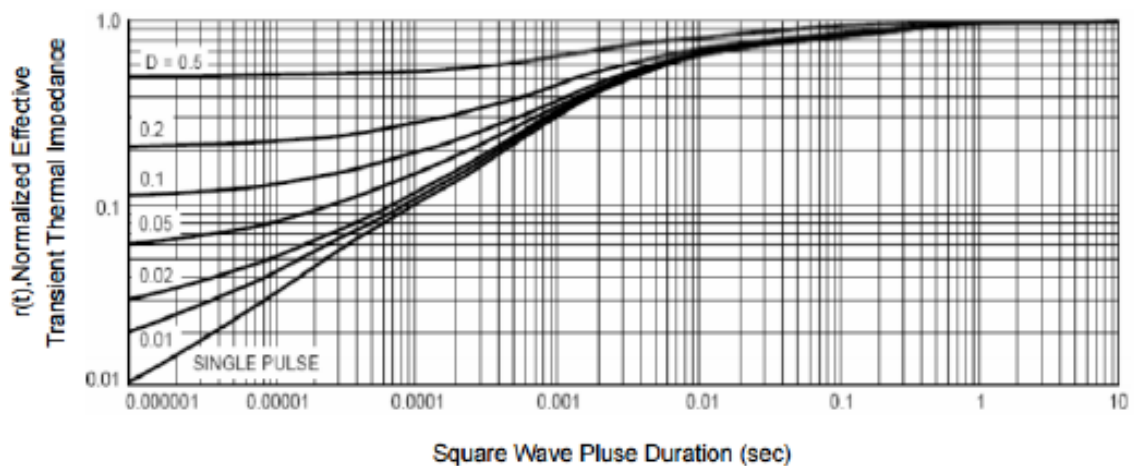

Figure 11 Normalized Maximum Transient Thermal Impedance

Test Circuits and Waveforms

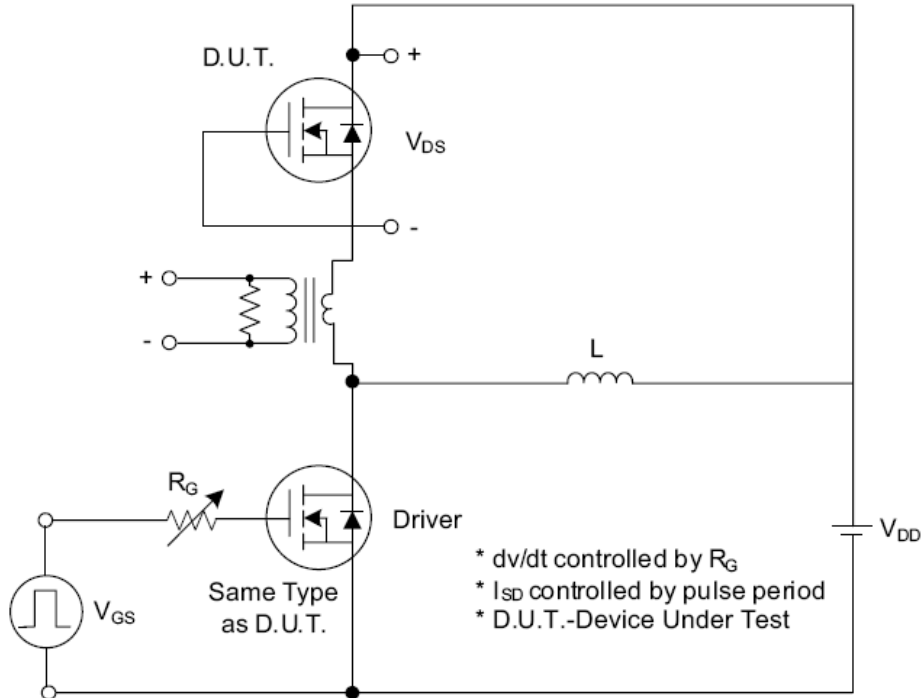

Fig. 1.1 Peak Diode Recovery dv/dt Test Circuit

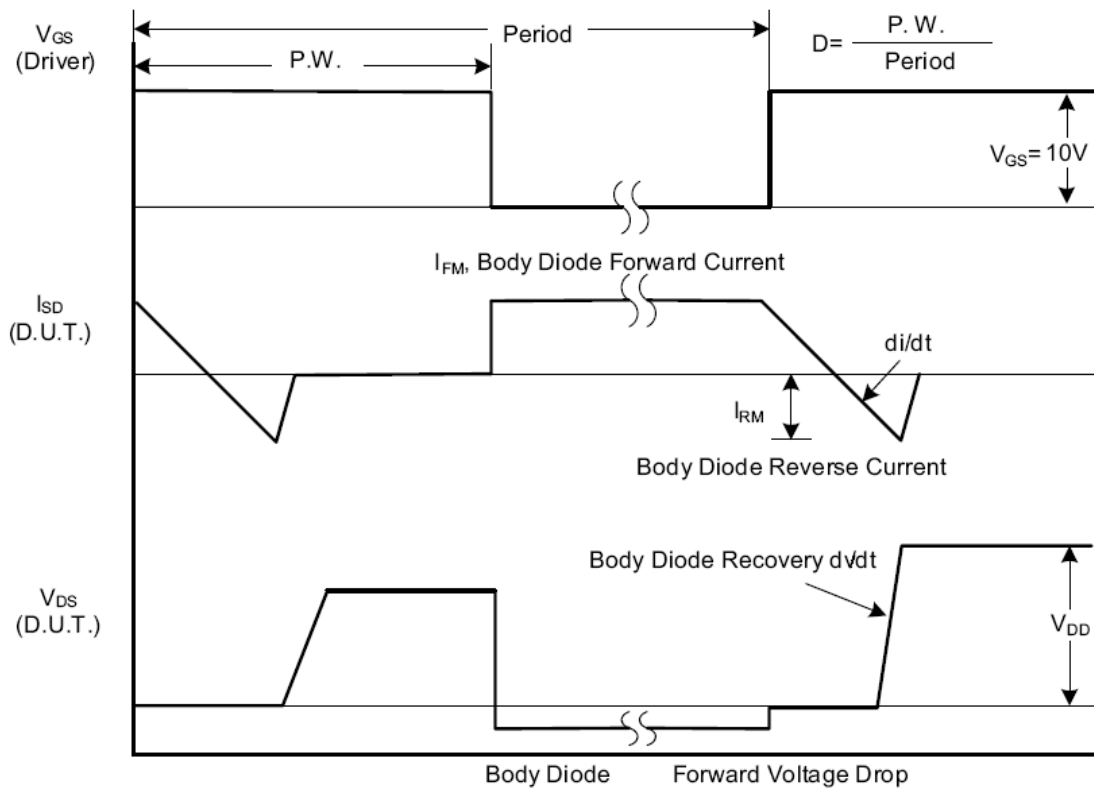

Fig. 1.2 Peak Diode Recovery dv/dt Waveforms

Test Circuits and Waveforms (Cont.)

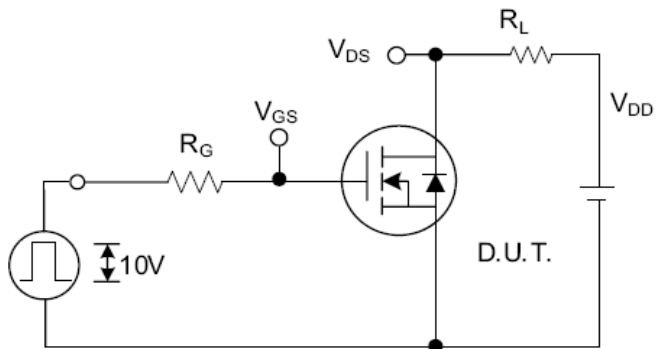

Fig. 2.1 Switching Test Circuit

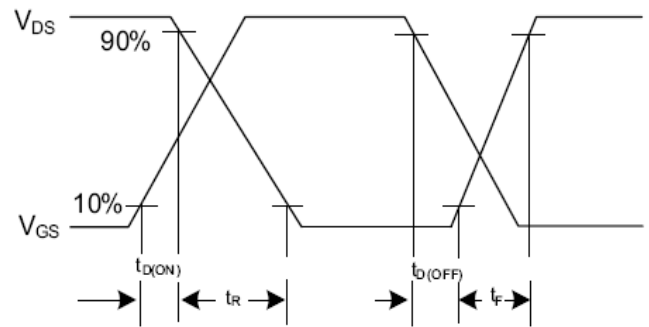

Fig. 2.2 Switching Waveforms

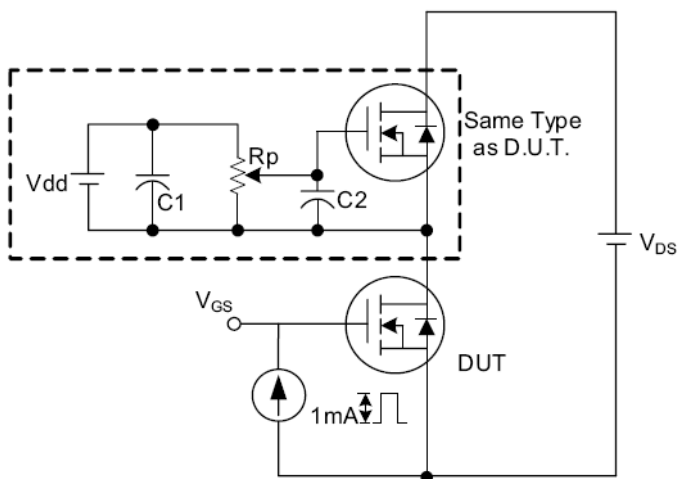

Fig. 3.1 Gate Charge Test Circuit

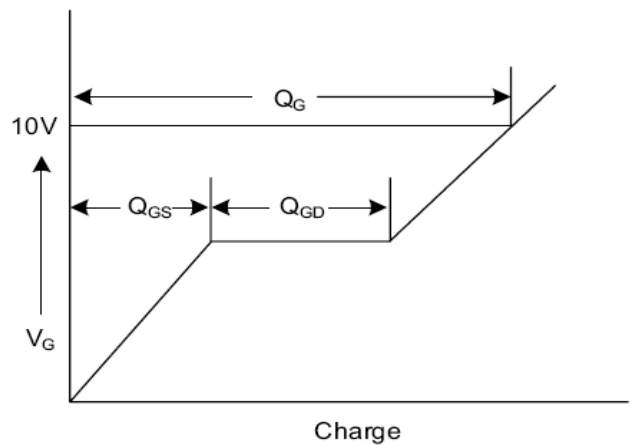

Fig. 3.2 Gate Charge Waveform

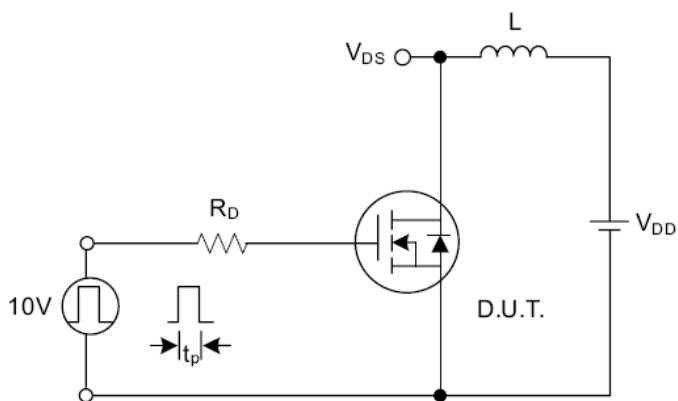

Fig. 4.1 Unclamped Inductive Switching Test Circuit

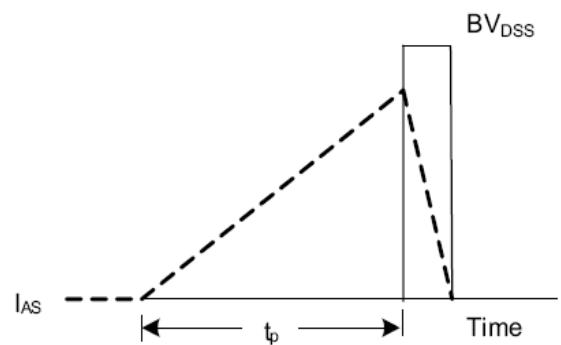
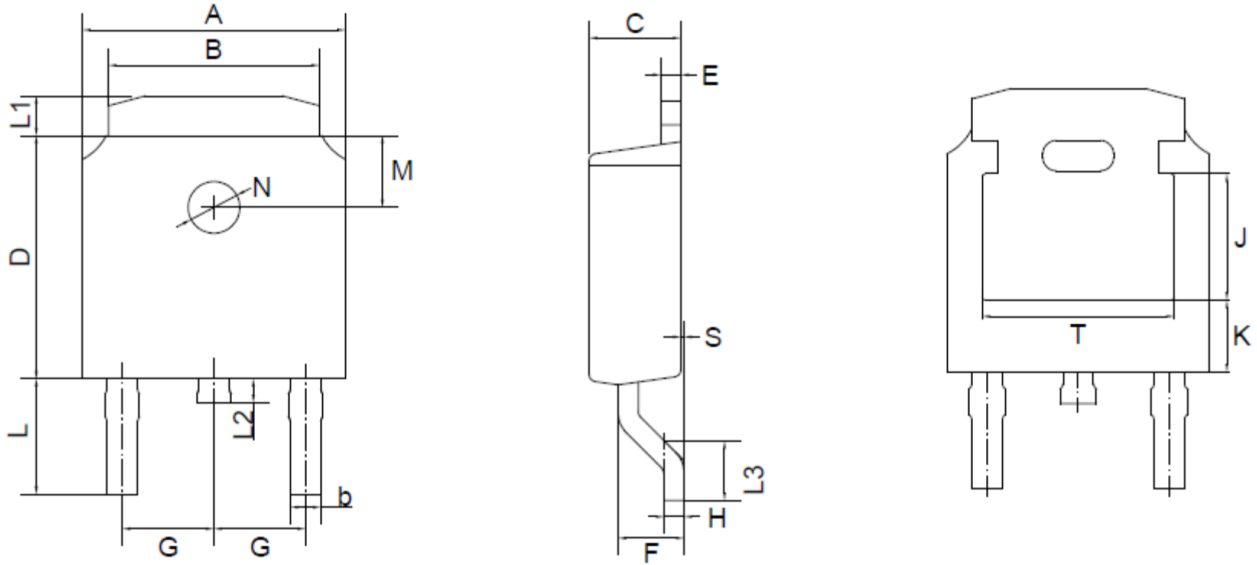

Fig. 4.2 Unclamped Inductive Switching Waveforms

PACKAGE OUTLINE

TO-252(D-PAK)



TO-252(D-PAK) mechanical data

UNIT	A	B	b	C	D	E	F	G	H	L	L1	L2	L3	S	M	N	J	K	T	
mm	max	6.7	5.5	0.8	2.5	6.3	0.6	1.8	2.29 TYPICAL	0.55	3.1	1.2	1.0	1.75	0.1	1.8 TYPICAL	1.3 TYPICAL	3.16 ref.	1.80 ref.	4.83 ref.
	min	6.3	5.1	0.3	2.1	5.9	0.4	1.3		0.45	2.7	0.8	0.6	1.40	0.0					
mil	max	264	217	31	98	248	24	71	90 TYPICAL	22	122	47	39	69	4	71 TYPICAL	51 TYPICAL	124 ref.	71 ref.	190 ref.
	min	248	201	12	83	232	16	51		18	106	31	24	55	0					

X-ON Electronics

Largest Supplier of Electrical and Electronic Components

Click to view similar products for [MOSFET](#) category:

Click to view products by [Shikues](#) manufacturer:

Other Similar products are found below :

[614233C](#) [648584F](#) [NTNS3A92PZT5G](#) [IRFD120](#) [IRFF430](#) [JANTX2N5237](#) [2N7000](#) [2SK2464-TL-E](#) [FCA20N60_F109](#) [FDZ595PZ](#) [AOD464](#)
[2SK2267\(Q\)](#) [2SK2545\(Q,T\)](#) [405094E](#) [423220D](#) [MIC4420CM-TR](#) [VN1206L](#) [614234A](#) [715780A](#) [SSM6J414TU,LF\(T](#) [751625C](#)
[IPP60R600P6XKSA1](#) [RJK60S5DPK-M0#T0](#) [PSMN4R2-30MLD](#) [TK31J60W5,S1VQ\(O](#) [2SK2614\(TE16L1,Q\)](#) [DMN1017UCP3-7](#)
[EFC2J004NUZTDG](#) [FCAB21350L1](#) [P85W28HP2F-7071](#) [DMN1053UCP4-7](#) [NTE2384](#) [NTE2969](#) [NTE6400A](#) [DMN2080UCB4-7](#)
[DMN61D9UWQ-13](#) [US6M2GTR](#) [DMN31D5UDJ-7](#) [SSM6P54TU,LF](#) [DMP22D4UFO-7B](#) [IPS60R3K4CEAKMA1](#) [DMN1006UCA6-7](#)
[DMN16M9UCA6-7](#) [STF5N65M6](#) [STU5N65M6](#) [C3M0021120D](#) [DMN13M9UCA6-7](#) [BSS340NWH6327XTSA1](#) [MCM3400A-TP](#)
[DMTH10H4M6SPS-13](#)