



深圳市首韩科技有限公司

SHENZHEN SHOUHAN TECHNOLOGY CO., LTD

Tel: 0755-27597601 Fax: 0755-27597491

承 认 书

SPECIFICATION FOR APPROVAL

客 户 Customer:

产品名称 Project:

拨动开关

规格型号 Part No:

MST23D18G2 125

贵公司承认印 Approval signatures

料 号/Part No.	签 章/Signatures

日期 Date:

拟制/Drawn	李春风	
审核/Check	钟华华	
批准/Approved	罗孝金	



产品名称: 拨动开关

产品型号: MST23D18G2

1: GENERAL SPECIFICATION 基本事项

1.1	RATING (额定值): DC 12V 100mA
1.2	PRACTICAL TEMPERATURE RANGE: -25°C~+70°C. 使用温度范围: 在-25°C~+70°C温度内使用.
1.3	STANDARD ATMOSPHERIC CONDITIONS : UNLESS OTHERWISE SPECIFIED. THE STANDARD RANGE OF ATMOSPHERIC CONDITIONS FOR MAKING MEASUREMENTS AND TESTS ARE AS FOLLOWS: (1) AMBIENT TEMPERATURE : 5°C TO 35°C; (2) RELATIVE HUMIDITY : 45% TO 85%; (3) AIR PRESSURE : 86Kpa TO 106Kpa. 测试标准状态: 在没有指定的情况下测试温度, 湿度, 气压如下: (1) 温度为5~35°C; (2) 湿度为45~85%; (3) 气压为86Kpa~106Kpa.

2. ELECTRICAL CHARACTERISTICS (电气性能规格):

ITEM	项目	TEST CONDITIONS 测试条件	PERFORMANCE (DATA) 规格(数据)
2.1	CONTACT RESISTANCE 接触电阻	MEASURED AT 1KHz SMALL CURRENT (100 mA OR LESS) 在1KHz微小电流(100mA 以下)测试.	100mΩ MAX. 100毫欧以下.
2.2	INSULATION RESISTANCE 绝缘电阻	APPLY A VOLTAGE OF 100V DC FOR 1 MIN. THE FOLLOWING CONTACT TEST METHOD: (1) BETWEEN BODY AND CONDUCTOR. (2) BETWEEN CONDUCTORS NOT TO BE CONTACT. 输入100V DC电压1分钟, 按以下接触方法测试: (1) 接触端子之间. (2) 胶座体和排脚之间.	100MΩ MIN. 100兆欧以上.
2.3	ELECTRIC STRENGTH 耐电压	AC 250V (50-60Hz) FOR 1 MIN TRIP CURRENT: 0.5mA THE FOLLOWING CONTACT TEST METHOD: (1) BETWEEN TERMINALS. (2) BETWEEN INDIVIDUAL TERMINALS AND FRAME. 输入AC250V (50-60Hz) 电压, 1分钟感度电流为0.5mA, 接触测试方法如下: (1) 接触端子之间. (2) 外壳体和排脚之间.	WITHOUT DAMAGE TO PARTS ARCING OR BREAKDOWN ETC. 没有绝缘破坏等异常

3. MECHANICAL CHARACTERISTICS (机械性能规格)

ITEM	项目	TEST CONDITIONS 测试条件	PERFORMANCE (DATA) 规格(数据)
3.1	OPERATION FORCE 动作力	LATERAL PUSH (侧向推动)	PUSH FORCE (按压力度): 200gf ± 30gf
3.2	TRAVEL TO CLOSURE 动作行程	IN THE HORIZONTAL DIRECTION SWITCH HANDLE OPERATION, WITH AN EQUAL TO 2TIMES THE THRUST OF THE SWITCH FROM ONE POSITION TO THE NEXT GEAR, MOVING DISTANCE MEASURING HANDLE. 在开关推柄运行的水平方向, 以一个等于2倍推力使开关从一个档位运动到下一档位, 测量推柄的移动距离.	2mm ± 0.15mm
3.3	STEM STRENGTH 操作部(柄)强度	AND ALONG THE RUNNING DIRECTION AT APEX HANDLE (500gf) ON THE STRENGTH TEST, TIME IS 30 SECONDS. 在推柄的先端沿运行方向加上(500gf)力度测试, 时间为30秒.	外观无异常, 满足于机械, 电气性能



产品名称: 拨动开关

产品型号: MSS22D18G2

4. DURABILITY (耐久性):

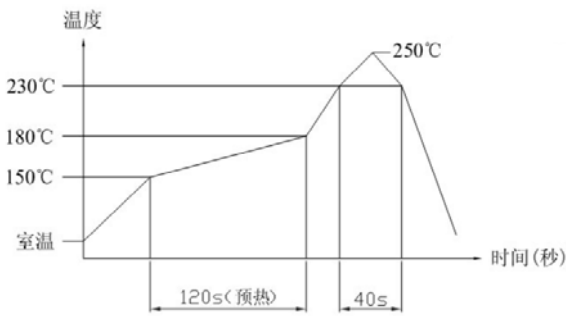
ITEM 项目	TEST CONDITIONS 测试条件	PERFORMANCE (DATA) 规格(数据)
4.1 LIFE TEST 寿命试验	AN ACTUATOR SHALL BE WITH A THRUST OF NO GREAT THAN 1 TIMES SWITH POWER TO 10000 CYCLES AT A SPEED OF 30 CYCLES FOR 1 MIN. 操者以每分钟30次的频率, 施加不大于开关1倍的推力做10000次无负荷测试.	1) CONTACT RESISTANCE SHALL BE 500mΩ MAX. 2) LIFETIME: 10000 次 1) 接触电阻不超于500mΩ. 2) 寿命: 10000次
4.2 HEAT TEST 耐热实验	THE SWITCH SHALL BE STORED AT A TEMPERATURE OF 85±2℃ FOR 96 HOURS. AND THEN IT SHALL BE SUBJECTED TO THE CONTROLLED RECOVERY CONDITIONS FOR 1 HOUR AFTER WHICH MEASUREMENT SHALL BE MADE. 放置在温度85±2℃中96小时后, 再放置正常室温中1小时后测定.	THERE SHALL BE NO DAMAGE ON APPEARANCE. MECHANICAL AND ELECTRICAL CHARACTERISTICS SHALL BE SATISFIED. 外观无异常, 满足于机械, 电气性能
4.3 COLD TEST 耐冷实验	THE SWITCH SHALL BE STORED AT A TEMPERATURE OF -25±3℃ FOR 96 HOURS. AND THEN IT SHALL BE SUBJECTED TO THE CONTROLLED RECOVERY CONDITIONS FOR 1 HOUR AFTER WHICH MEASUREMENT SHALL BE MADE. 放置在温度-25±3℃中96小时后, 再放置正常室温中1小时后测定.	
4.4 HUMIDITY TEST 潮湿实验	THE SWITCH SHALL BE STORED AT A TEMPERATURE OF 40±2℃ AND A HUMIDITY OF 80% TO 85% FOR 96 Hr. THEN THE JACK SHALL BE MAINTAINED AT STANDARD ATMOSPHERIC CONDITION FOR 1 Hr FOR OTHER PROCEDURES. 放置在40±2℃相对湿度为80~85%环境中96小时后, 再将样品放在正常室温中1小时后测定.	
4.5 SOLDERING CONDITIONS 焊锡条件	HAND SOLDERING 手焊: 1) DIVCE 工具: SOLDER IRON 电烙铁. A. 350℃MAX., 2 sec Max B. 270℃MAX., 4 sec Max 2) REFLOW SOLDERING 回流焊: ≤250℃ 	

1 2 3 4 5 6

A

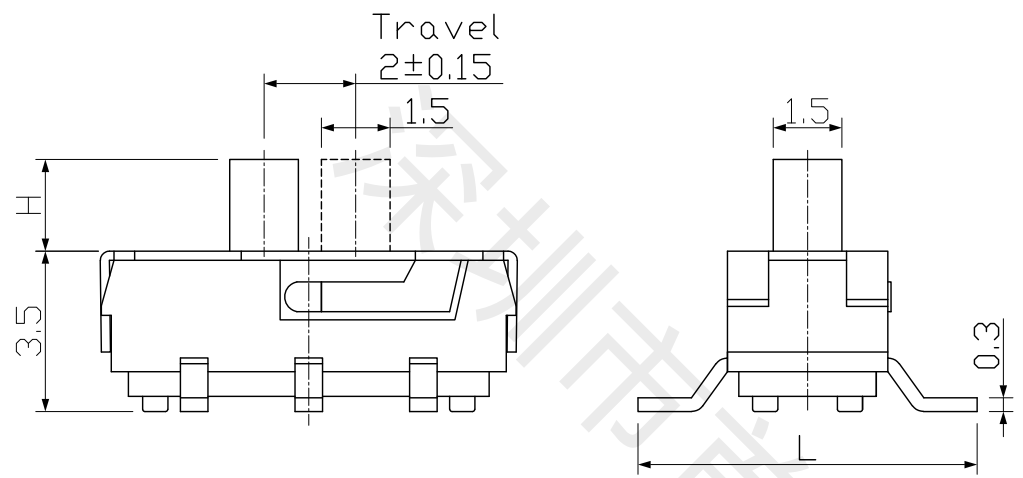

L	H
6.9	1.7
/	2.0
7.4	3.0
	4.0

电路简图
SCHEMATIC

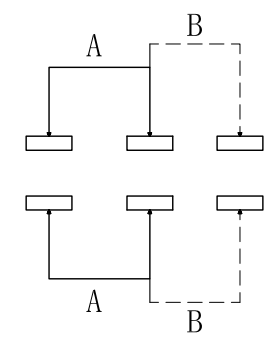

B

- 1、工作电压 Working Voltage: 12V DC;
- 2、工作电流 Working Current: 0.1A;
- 3、接触电阻 Contact Resistance: $\leq 100m\Omega$;
- 4、绝缘电阻 Insulation Resistance: $\geq 100M\Omega$;
- 5、动作力 Press Force: $200\pm 30gf$;
- 6、寿命 Life: $>10,000$ 次。

印制线路板
Recommended P.C.B layout

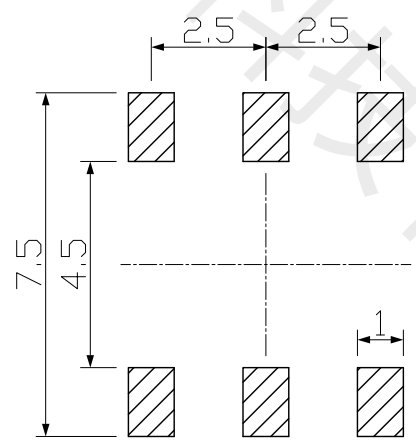
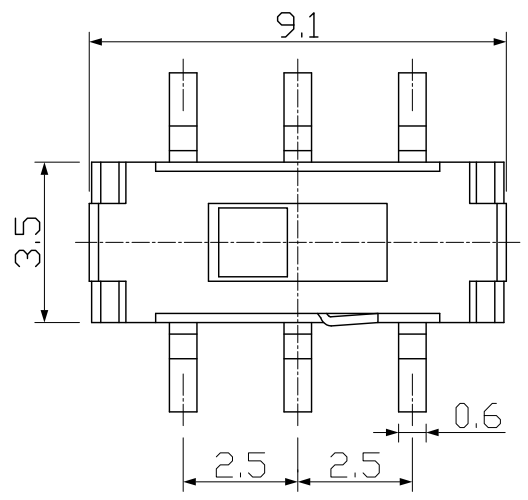

C

5	盖板	SUS	-----	-----
4	推柄	PA46	黑色	-----
3	簧片	镀铜	-----	表面镀银
2	基座	PA46	黑色	-----
1	端子	H62Y	-----	表面镀银
NO.	DESCRIPTION	MATERIAL	COLOR	REMARK

首韩 深圳市首韩科技有限公司

D

				X. $\pm 2^\circ$.X ± 0.5	DRAW	繪圖員	名稱 TITLE	六脚拨动立式贴片							
				.XX $\pm 1^\circ$.XX ± 0.3	DESIGN	設計	型號 TYPE NO.	MST22D18G2 125							
				.XX $\pm 0.5^\circ$.XX ± 0.1	CHECH	審核	圖號 DRAWING NO.								
工程變更通知單 ECN (DCN) NO.	版次 REV.	日期 DATE	說明 DESCRIPTION	改變 CHANGE	審核 APPRO.	一般公差	APPRO.	批准	SCALE	1:1	UNIT	mm	視角		版本	A

1 2 3 4 5 6

1 2 3 4 5 6

A

A

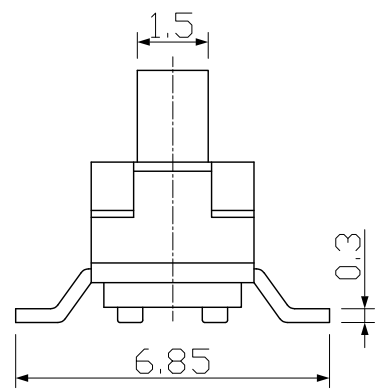
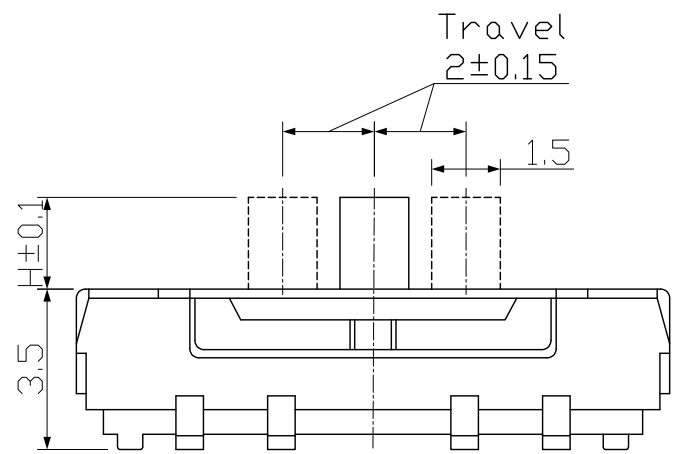

H
1.5
2.0
2.5
3.0
4.0
5.0

电路简图
SCHEMATIC

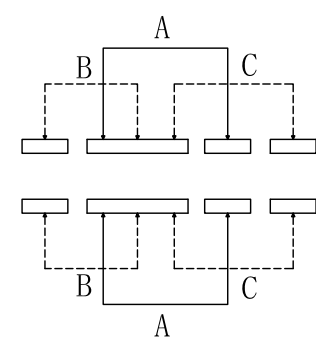

B

B

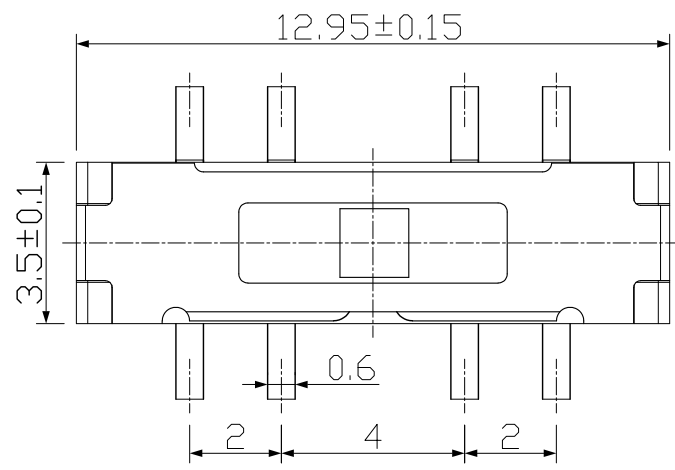

印制线路板
Recommended P.C.B layout

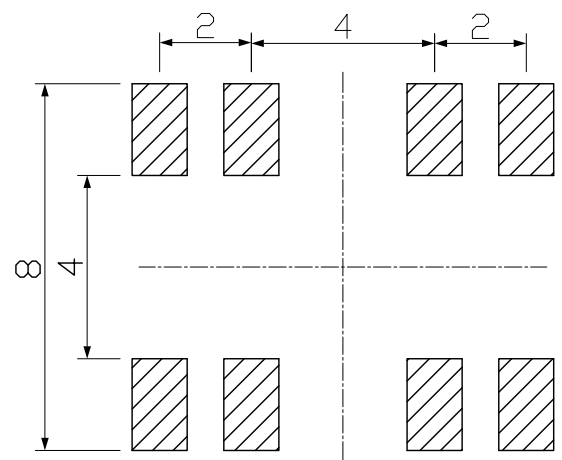

- 1、工作电压 Working Voltage: 12V DC;
- 2、工作电流 Working Current: 0.1A;
- 3、接触电阻 Contact Resistance: $\leq 100m\Omega$;
- 4、绝缘电阻 Insulation Resistance: $\geq 100M\Omega$;
- 5、动作力 Press Force: $200\pm 30gf$;
- 6、寿命 Life: $>10,000$ 次。

C

C

5	盖板	SUS	-----	-----
4	推柄	PA46	黑色	-----
3	簧片	铍铜	-----	表面镀银
2	基座	PA46	黑色	-----
1	端子	H62Y	-----	表面镀银
NO.	DESCRIPTION	MATERIAL	COLOR	REMARK

首韩 深圳市首韩科技有限公司

D

D

						X. $\pm 2^\circ$.X ± 0.5	DRAW	繪圖員	名稱	八脚拨动立式贴片								
						.XX $\pm 1^\circ$.XX ± 0.3	DESIGN	設計	李春风	型號	MST23D18G2 125							
						.XX $\pm 0.5^\circ$.XX ± 0.1	CHECH	審核	钟华华	圖號								
						角度	尺寸	APPRO.	批准	罗孝金	DRAWING NO.	SCALE	1:1	UNIT	mm	视角	版本	A	
工程變更通知單	版次	日期	說明	改變	審核	一般公差													
ECN (DCN) NO.	REV.	DATE	DESCRIPTION	CHANGE	APPRO.														

1 2 3 4 5 6

X-ON Electronics

Largest Supplier of Electrical and Electronic Components

Click to view similar products for [Slide Switches](#) category:

Click to view products by [SHOU](#) manufacturer:

Other Similar products are found below :

[6-1437581-1](#) [M43R](#) [MHS123K15D](#) [MHS133K](#) [MMD](#) [MSS12A](#) [1825074-1](#) [1825160-3](#) [1825167-2](#) [1825289-7](#) [K232CB](#) [25139NLDB](#)
[25449NAH](#) [1825078-1](#) [1825080-4](#) [1825269-1](#) [1825270-2](#) [STS141RA04](#) [T2215BEN506](#) [GH46P000001](#) [GH49P010001](#) [25339NA](#)
[25436NLDH](#) [M42A](#) [AYZ0202AG](#) [L203091MS02Q](#) [4-1437581-7](#) [48BFSP3M2QT](#) [1101M1S3ZB8E2](#) [1-1437581-1](#)
[EG1218REDACTUATOR](#) [MSS2225G04](#) [MSS42G](#) [T105S1CWZBE](#) [SLB124145](#) [SLB1280R5](#) [TG39W000050](#) [25149NAH](#) [25439NAH](#)
[25436NAH6](#) [TG36Y000050](#) [NK236X693](#) [SL-1211C1B8](#) [46204LRX](#) [1977143-4](#) [1977144-4](#) [1977145-4](#) [HASS0194](#) [JS0001](#) [SSJ12R04](#)