



深圳市首韩科技有限公司

SHENZHEN SHOUHAN TECHNOLOGY CO.,LTD

Tel: 0755-27597601

Fax: 0755-27597491

承认书

名称规格: 4*4铜头系列

客户料号:

工程部印章 刘小军	客户确认
------------------	------

联络人: 罗孝金

TACT SWITCH SPECIFICATION(轻触开关说明书)

6.2 Mechanical 机械特性

Item 项目	Test Condition 试验条件	Requirements 规格
6.2.1. Actuating Force 动作力	Placing the switch such that the direction of switch operation is vertical and then gradually increasing the load applied to the center of the stem, the maximum load required for the stem to come to a stop shall be measured. 开关的动作方向为垂直放置开关向推柄中心逐渐增加负荷直到推柄停止时所测量的最大负荷	<u>260</u> ± 30 gf
6.2.2. Travel 行程	Placing the switch such that the direction of switch operation is vertical and then applying a static load twice the actuation force to the center of the stem, the travel distance for the stem to come to a stop shall be measured. 开关的动作方向为垂直放置开关，在已有行程的推柄中心向上减小压力，推柄回到自由位置时所测到的力	0.25 ± 0.05 mm
6.2.3. Return Force 返回力	The sample switch is installed such that the direction of switch operation is vertical and, upon depression of the stem in its center the whole travel distance, the force of the stem to return to its free position shall be measured. 开关的动作方向垂直放置开关，在已有行程的推柄中心向上减小压力，推柄回到自由位置时所测量到的力	<u>200</u> gf min
6.2.4. Stop Strength 静止强度	Placing the switch such that the direction of switch operation is vertical, a static load of <u>3</u> kgf shall be applied in the direction of stem operation for a period of <u>60</u> seconds. 开关的动作方向为垂直放置开关，在推柄动作方向施加 3 KG 的静负荷，60 秒时间	There shall be no sign of damage mechanically and electrically 无机械的和电气的损伤迹象
6.2.5. Stem Strength 推柄的强度	Placing the switch such that the direction of switch operation is vertical, the maximum force to withstand a pull applied oppsite to the direction of stem operation shall be measured. 开关的动作方向为垂直放置开关从推柄动作方向反方向施加拉力所测量到的最大承受力	2 kgf

						APPD	CHKD	DSGD	MODEL NO:	
ZONE	SYMB	DATE	APPD	CHKD	DSGD					

TACT SWITCH SPECIFICATION(轻触开关说明书)

6.PERFORMANCE 性能

6.1 Electrical 电气

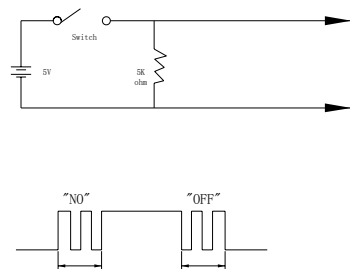
Item 项目	Test Condition 试验条件	Requirements 要求
6.1.1. Contact Resistance 接触电阻	Applying a static load twice the actuating force to the center of the stem, measurements shall be made with a 1 kHz small-current contact resistance meter. 用两倍的动作用力作静负载施加于按钮的中心，并用 1 千赫小电流接触电阻仪测量	<u>50</u> mΩmax.
6.1.2. Insulation Resistance 绝缘电阻	Measurements shall be made following application of DC 100 V potential across terminals and across terminals and frame for one minute. 在端子之间，端子与外壳之间施加 DC100V，一分钟	<u>100</u> MΩmin
6.1.3. Dielectric Withstanding voltage 电气耐压	AC250V (50Hz or 60Hz) shall be applied across terminals and across terminals and frame for one minute. 在端子与端子之间，端子与外壳之间施加 AC250V(50Hz or 60Hz)	There shall be no breakdown 没有击穿
6.1.4. Bounce 抖动	Lightly striking the center of the stem at a rate encountered in normal use (3 to 4 operations per sec), Bounce shall be tested at “ON” and “OFF” 在正常使用中(以每秒 3-4 次周期)轻轻地在手柄中心加力，在通与断瞬间测试抖动。 <div style="text-align: center;">  </div>	<u>5</u> m sec max .

						APPD	CHKD	DSGD	MODEL NO:
ZONE	SYMB	DATE	APPD	CHKD	DSGD				

TACT SWITCH SPECIFICATION(轻触开关说明书)

6.3 Environmental 环境

Item 项目	Test Condition 试验条件	Requirements 要求									
6.3.1. Resistance to Low Temperatures 耐低温	Following the test set forth below the sample shall be left in normal temperature and humidity conditions for one hour before measurements are made: 样品按下列条件进行耐低温试验, 测试前在正常温度和湿度条例上放置 1 小时 (1) Temperature: $-40 \pm 5^{\circ}\text{C}$ 温度 (2) Time: 96 hours 时间 (3) Water drops shall be removed 擦除水珠	Item 6.1 Item 6.2.1 Item 6.2.2									
6.3.2. Heat Resistance 耐热	Following the test set forth below the sample shall be left in normal temperature and humidity conditions for one hour before measurements are made: 样品按下列条件进行耐热试验, 测试前在正常温度和湿度条件下放置 1 小时 (1) Temperature: $270 \pm 20^{\circ}\text{C}$ 温度 (2) Time: 96 hours 时间	Item 6.1 Item 6.2.1 Item 6.2.2									
6.3.3. Moisture Resistance 耐潮湿	Following the test set forth below the sample shall be left in normal temperature and humidity conditions for one hour before measurements are made: 样品按下列条件进行耐潮湿试验, 测试前在正常温度和湿度条件下放置 1 小时 (1) Temperature: $40 \pm 2^{\circ}\text{C}$ 温度 (2) Relative humidity: 90 to 95% 相对湿度 (3) Time: 96 hours 时间 (4) Water drops shall be removed 擦除水珠	Item 6.1 Item 6.2.1 Item 6.2.2									
6.3.4. Temperature Cycling 温度循环	Following the test set forth below the sample shall be left in normal temperature and humidity conditions for one hour before measurements are made. 样品按下列条件进行温度循环试验, 测试前在正常温度和湿度条件下放置 1 小时 During this test, water drops shall be removed, 在试验期间, 擦除水珠。 <div style="text-align: center;"> </div>	Item 6.1 Item 6.2.1 Item 6.2.2									
	<table border="1" style="margin: auto; border-collapse: collapse;"> <tr> <td style="width: 20px; height: 20px;"></td> <td style="width: 20px; height: 20px;"></td> <td style="width: 20px; height: 20px;"></td> <td style="width: 20px; height: 20px;"></td> <td style="width: 20px; height: 20px;"></td> <td style="width: 20px; height: 20px;"></td> <td style="width: 20px; height: 20px; text-align: center;">APPD</td> <td style="width: 20px; height: 20px; text-align: center;">CHKD</td> <td style="width: 20px; height: 20px; text-align: center;">DSGD</td> </tr> </table>							APPD	CHKD	DSGD	PARTNO:
						APPD	CHKD	DSGD			
ZONE	SYMB	DATE	APPD	CHKD	DSGD						

TACT SWITCH SPECIFICATION(轻触开关说明书)

6.4 Endurance 耐久性

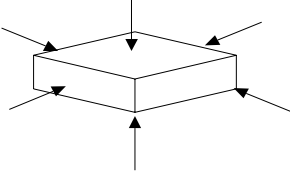
Item 项目	Test Condition 试验条件	Requirements 要求
<p>6.4.1. Operating Life 动作寿命</p>	<p>Measurements shall be made following the test set forth below:</p> <p>(1)DC 5V 5mA resistive load . DC 5V 5mA 阻性负载</p> <p>(2) Rate of operation : 2 to 3 operations per second 动作频率: 2-3 次/每秒</p> <p>(3)Depression : <u>160</u>_gf 动作力</p> <p>(4) Cycles of operation : 100 000cycles 动作次数 100 000</p>	<p>Contact resistance: 50m Ω max 接触电阻</p> <p>Insulation resistance 100M Ω min.绝缘电阻</p> <p>Actuating force: 动作力 +<u>30</u> % or -<u>30</u>%of initial force. ±30%初 始动作力</p> <p style="text-align: right;">Item 6.1.3 Item 6.2.2</p>
<p>6.4.2. Vibration Resistance 耐振动</p>	<p>Measurements shall be made following the test set forth below: 按下列条件进行抗振动试验</p> <p>(1) Range of oscillation : 10 to 55 Hz 频率范围</p> <p>(2) Amplitude,pk-to -pk : 1.5mm 振幅: 峰-峰 1.5mm</p> <p>(3) Cycle of sweep : 10-55-10Hz in one minute, approx</p> <p>(4) Mode of sweep : Logarithmically sweep or</p> <p>(5) uniform sweep. 扫描周期: 10-55-10-Hz 约一分钟内</p> <p>(6) Direction of oscillation: 振动方向 Three mutually perpendicular directions, including the direction of stem travel, 3个相互垂直方向, 包括推柄行程方向</p> <p>(7) Duration of testing 持续时间 2 hours each ,for a total of 6hours. 每方向 2 小时, 共 6 小时</p>	<p>Item 6.1 Item 6.2.1 Item 6.2.2</p>
<p>6.4.3. Impact Shock Resistance 抗冲击</p>	<p>Measurements shall be made following the test set forth below: 按下列条件进行冲击试验</p> <p>(1) Acceleration : 80g 加速度</p> <p>(2) Cycles of test :3 cycles each in 6 directions,</p> <p>(3) for a total of 18cycles 试验次数: 每个方向 3 次, 6 个方向共 18 次</p> <div style="text-align: center;">  </div>	<p>Item 6.1 Item 6.2.1 Item 6.2.2</p>

						APPD	CHKD	DSGD	PARTNO:	
ZONE	SYMB	DATE	APPD	CHKD	DSGD					

TACT SWITCH SPECIFICATION(轻触开关说明书)

7. Conditions for soldering 焊接条件

Reflow soldering conditions 回流焊条件

Preheat: Temperature on the copper foil surface should reach 180°C, 2±0.3 minutes after

The P.W.B entered into the soldering equipment

预热: 在 P.W.B(印刷线路板)进入焊接设备后, 2±0.3 分钟内铜箔表面要达到 180°C

Soldering heat: Temperature on the copper foil surface should reach the peak temperature of 265°C

within 20 seconds after the P.W.B entered into soldering heat zone.

焊接温度: 在 P.W.B (印刷线路板)进入焊接温区 20 秒内, 铜箔表面达到峰值温度 265°C

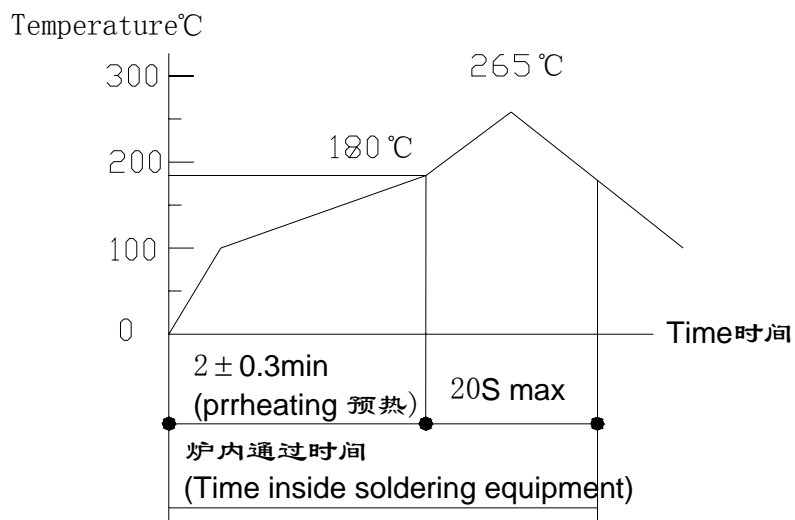

**Time inside soldering Equipment
Temperature Profile**

						APPD	CHKD	DSGD	PARTNO:	
ZONE	SYMB	DATE	APPD	CHKD	DSGD					

TACTING SWITCH SPECIFICATION

7.1 Other precautions 其他注意事项

(1) Following the soldering process,do not try to clean the switch with a solvent or the like .

进行焊接过程中，不可以用溶剂或类似品清洗开关

(2) Safeguard the switch assembly against flux penetration from its topside.

防止助焊剂从开关的顶端渗入。

(3) Please have the products keep in close status and the storage time is 90 days guaranty after

delivering the goods at most.

交货后保证开关处于封密状态并库存时间不超过 90 天以上

						APPD	CHKD	DSGD	PARTNO:	
ZONE	SYMB	DATE	APPD	CHKD	DSGD					

TACT SWITCH SPECIFICATION(轻触开关说明书)

8.

★ ★ ★ SWITCH HANDLING PRECAUTION ★ ★ ★

使用开关时注意事项

1. IN CASE AN AUTOMATIC FLOW SOLDERING APPARATUS IS USE FOR SOLDERING
用自动焊接设备焊接时应参照如下条件

ITEM 项目	SOLDERING CONDITIONS 焊接条件
(1)PREHEAT TEMPERATURE 预热温度	100℃ MAX (AMBIENT TEMPERATURE OF PRINTED CIRCUIT BOARD ON ITS SOLDERING SIDE) (电路板周围焊锡面的温度)
(2)PREHEAT TIME 预热时间	45 SEC MAX 45 秒 MAX
(3)FLUX FOAMING 助焊剂浸泡	TO SUCH AN EXTENT THAT FLUX WILL BE KEPT FLUSH WITH THE PRINTED CIRCUIT BOARDS, TOP SURFACE ON WHICH COMPONENTS ARE MOUNTED. PRDPARATORY FLUX MUST NOT BE APPLIED TO THAT SODE OF PRINTED CIRCUIT BOARD ON WHICH COMPONENTS ARE MOUNTED AND TO THE AREA WHIERE TERMINALS ARE LOCATED. 助焊剂应涂在电路板上组装开关的印刷面上半部位,应防止 助焊剂过量到电路板.
(4)SOLDERIN TEMPERATURE 焊锡温度	255℃ MAX 255℃ MAX
(5)DURATION OF SOLDER IMMERSION 焊接时间	5 SEC MAX 5 秒 MAX
(6)ALLOWABLE PREQUENCY 允许重焊次数	2 TIMES MAX 2 次 MAX

2. OTHER PRECAUTIONS 其他注意事项

- (1) FOLLOWING THE SOLDERING PROCESS, DO NOT TRY TO CLEAN THE SWITCH SOLVENT OR THE LIKE
进行焊接工艺时不应使用不整洁的东西对开关进行清洁。
- (2) SAFEGUARD THE SWITCH ASSEMBLY AGAINST FLUX PENETRA TION FROM ITS TOP SIDE
在组装开关时应防止助焊剂从开关的上部流入到开关内部

						APPD	CHKD	DSGD	PARTNO: TS44____
									9/10
ZONE	SYMB	DATE	APPD	CHKD	DSGD				

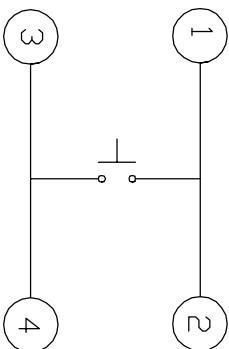
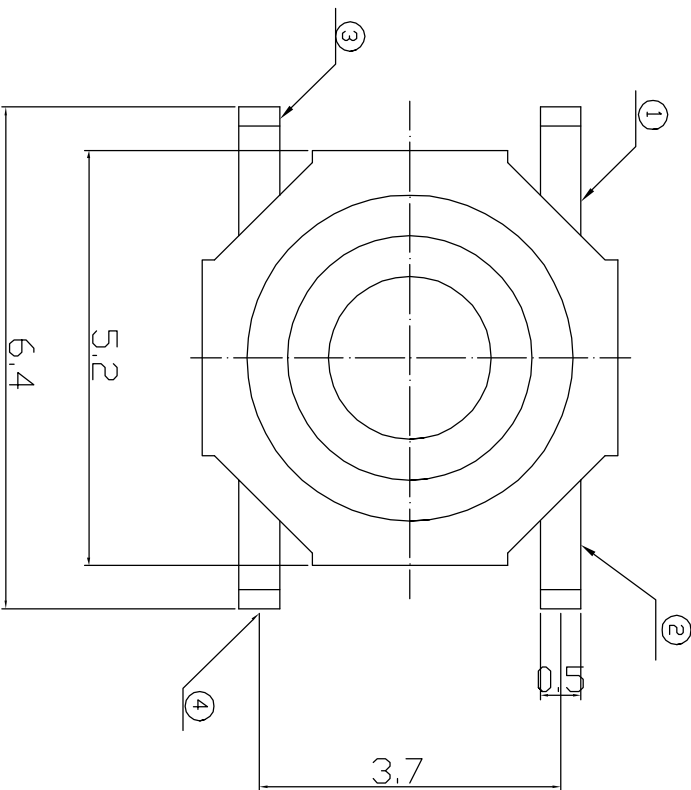
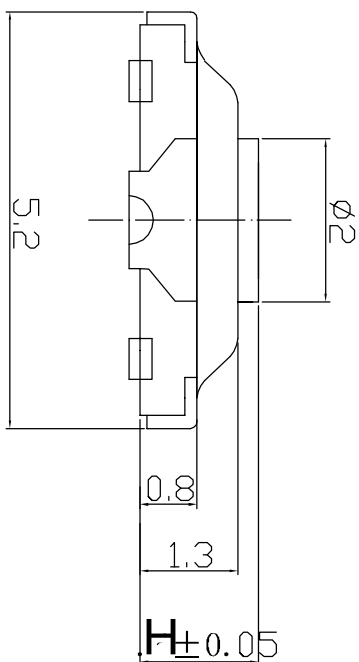
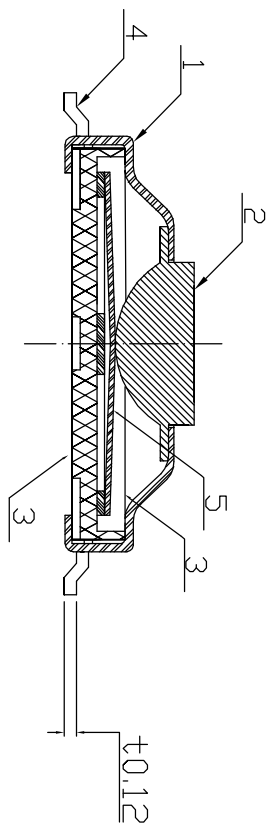

總工程師

H=1.5/1.6/1.7/2.0/2.5/3.0/3.5

1. Rating: DC12V 50mA.
2. Travel: 0.2 ± 0.1 mm.
3. Operating Force: 160 ± 30 gf or 260 ± 30 gf.
4. Contact Resistance: $100m \Omega$ Max.
5. Life: 80000 Cycles Min.

深圳市首韩科技有限公司

CUSTOMER 名稱
COPY TITLE:

型號
TYPE NO.

料號
PART NO.(OLD)

圖號
DRAWING NO.

SCALE

繪圖員 黃文丹
DESIGN 01/06/04

設計 廖河雄
01/06/04

校閱 劉伟
DRAWING NO. A
VS1415_Rev018

承認 趙章益
SCALE 5:1

UNIT mm

紙張 A4

圖號 A

圖號 A

更改	承認	GENERAL TOLERANCE UNLESS OTHERWISE NOTED	Angle	±2°	繪圖員	黃文丹	01/06/04
CHANGE	APPRO.		30~	±0.5	設計	廖河雄	01/06/04
			10~30	±0.3	校閱	劉伟	
			~10	±0.15	承認	趙章益	
日期	描述						
REV	DESCRIPTION						
01/06/04	NEW						
P0							
版次							
REV							
01/06/04							
日期							
DATE							
01/06/04							
版次							
REV							
01/06/04							
日期							
DATE							
01/06/04							
版次							
REV							
01/06/04							
日期							
DATE							
01/06/04							
版次							
REV							
01/06/04							
日期							
DATE							
01/06/04							
版次							
REV							
01/06/04							
日期							
DATE							
01/06/04							
版次							
REV							
01/06/04							
日期							
DATE							
01/06/04							
版次							
REV							
01/06/04							
日期							
DATE							
01/06/04							
版次							
REV							
01/06/04							
日期							
DATE							
01/06/04							
版次							
REV							
01/06/04							
日期							
DATE							
01/06/04							
版次							
REV							
01/06/04							
日期							
DATE							
01/06/04							
版次							
REV							
01/06/04							
日期							
DATE							
01/06/04							
版次							
REV							
01/06/04							
日期							
DATE							
01/06/04							
版次							
REV							
01/06/04							
日期							
DATE							
01/06/04							
版次							
REV							
01/06/04							
日期							
DATE							
01/06/04							
版次							
REV							
01/06/04							
日期							
DATE							
01/06/04							
版次							
REV							
01/06/04							
日期							
DATE							
01/06/04							
版次							
REV							
01/06/04							
日期							
DATE							
01/06/04							
版次							
REV							
01/06/04							
日期							
DATE							
01/06/04							
版次							
REV							
01/06/04							
日期							
DATE							
01/06/04							
版次							
REV							
01/06/04							
日期							
DATE							
01/06/04							
版次							
REV							
01/06/04							
日期							
DATE							
01/06/04							
版次							
REV							
01/06/04							
日期							
DATE							
01/06/04							
版次							
REV							
01/06/04							
日期							
DATE							
01/06/04							
版次							
REV							
01/06/04							
日期							
DATE							
01/06/04							
版次							
REV							
01/06/04							
日期							
DATE							
01/06/04							
版次							
REV							
01/06/04							
日期							
DATE							
01/06/04							
版次							
REV							
01/06/04							
日期							
DATE							
01/06/04							
版次							
REV							
01/06/04							
日期							
DATE							
01/06/04							
版次							
REV							
01/06/04							
日期							
DATE							
01/06/04							
版次							
REV							
01/06/04							
日期							
DATE							
01/06/04							
版次							
REV							
01/06/04							
日期							
DATE							
01/06/04							
版次							
REV							
01/06/04							
日期							
DATE							
01/06/04							
版次							
REV							
01/06/04							
日期							
DATE							
01/06/04							
版次							
REV							
01/06/04							
日期							
DATE							
01/06/04							
版次							
REV							
01/06/04							

X-ON Electronics

Largest Supplier of Electrical and Electronic Components

Click to view similar products for [Tactile Switches](#) category:

Click to view products by [SHOU](#) manufacturer:

Other Similar products are found below :

[KMR633NG](#) [LFG](#) [5GTH92001](#) [5GTH9202242](#) [6426-201-11343](#) [MJ1226](#) [MJTP1109B](#) [MJTP1138EAUTR](#) [MJTP1230BL](#) [MJTPSHW](#)
[GS6.90F300QP](#) [1-1977223-0](#) [1-1977120-4](#) [ADTSA62NV](#) [ADTSA62RV](#) [ADTSA63KV](#) [ADTSA644NV](#) [ADTSM24NVTR](#) [ADTSMW66NV](#)
[ADTSMW67RV](#) [ATM533VTR](#) [1571300-3](#) [B3F-3123](#) [B3F-6055A](#) [B3F-B32-01-KIT](#) [1977177-8](#) [1977266-1](#) [2-1977223-4](#) [2-1977223-7](#)
[ADTS644KV](#) [ADTSA61RV](#) [ADTSA62KV](#) [ADTSA63NV](#) [ADTSA63RV](#) [ADTSA65NV](#) [ADTSM21NSVTR](#) [ADTSM25RVTR](#)
[ADTSM31RVTR](#) [ADTSM32NVTR](#) [ADTSM61YVTR](#) [ADTSM63SVTR](#) [ADTSM644KVTR](#) [ADTSMW64RV](#) [ADTSMW69NV](#)
[FSMRA4JHA04](#) [GS4.70F300QP](#) [D38999/20JJ37SA](#) [TL1105B](#) [TL1105J](#) [ATH447K2Q](#) [ATM534VTR](#)