

Advanced Linear Charge Management Controller

Features

- Preset 8.4V (TYP.) Charge Voltage with 1% Accuracy
- Programmable Charge Current Up to 0.9A
- Absolute Maximum Input Voltage: 30V
- Wide Input Operation Voltage: 9V ~ 13.5V
- Pre-Charging, the Charge Current is adjustable
- Ideal for Dual-Cell (8.4V) Li-Ion Batteries
- Constant -Current Charging, the Charge Current is adjustable
- Constant-Voltage Charging
- Constant-Current/Constant-Voltage Charging with Temperature Monitoring
- Automatic Recharge
- Double LEDs Charge Status Indication
- Available in SOP-8L Package

Applications

- Charger for Li-Ion Coin Cell Batteries
- Bluetooth Applications
- Portable MP3 Players, Wireless Headsets

Description

The GS7001B is a highly advanced complete constant-current/ constant voltage linear charger for cell lithium-ion batteries. Its package and low external component count make the GS7001B ideally suited for portable applications. The charge current can be programmed externally with a single resistor, which may be programmed up to 0.9A. GS7001B determines the charge mode by detecting the battery voltage: Pre-charge, constant current charging, constant voltage charging. The charge current of 0pre-charging and constant-current charging is adjustable. The GS7001B is monitored by temperature monitor during the constant-current and constant-voltage charging. There are two LEDs indicate the charge mode.

The GS7001B is available in the SOP-8L package.

Ordering Information

Device	Package Options
	8-Lead SOIC
GS7001B	GS7001B-84



Typical Application Circuit

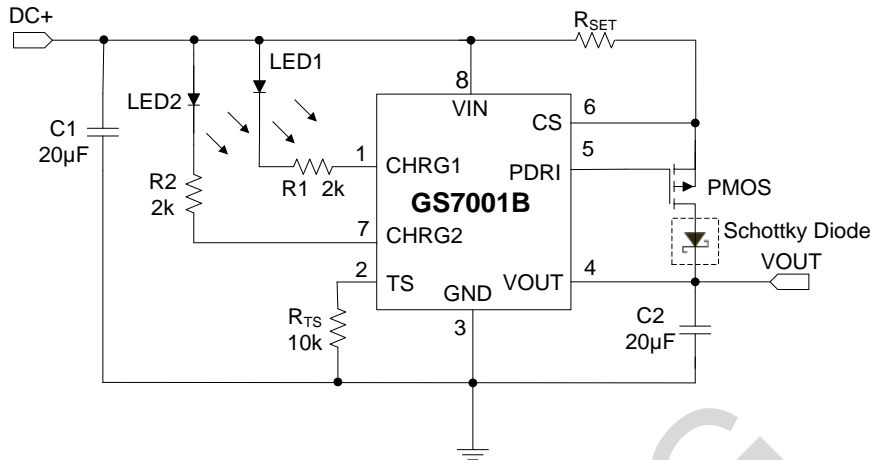

*The charge current $I_{O(REG)} = V_{CS} / R_{SET}$ (V_{CS} is usually 200mV). Note that OFF indicates the LED is turned off.

*The reverse-blocking protection diode is optional. In addition, the reverse-leakage current of the diode should be kept as small as possible.

Condition	LED1	LED2
No-Load(Note 1)	Flash	Flash
Battery Charging	ON	OFF
Charge Complete(Done)	OFF	ON
OVP	OFF	OFF

Table1. Charge Status Summary

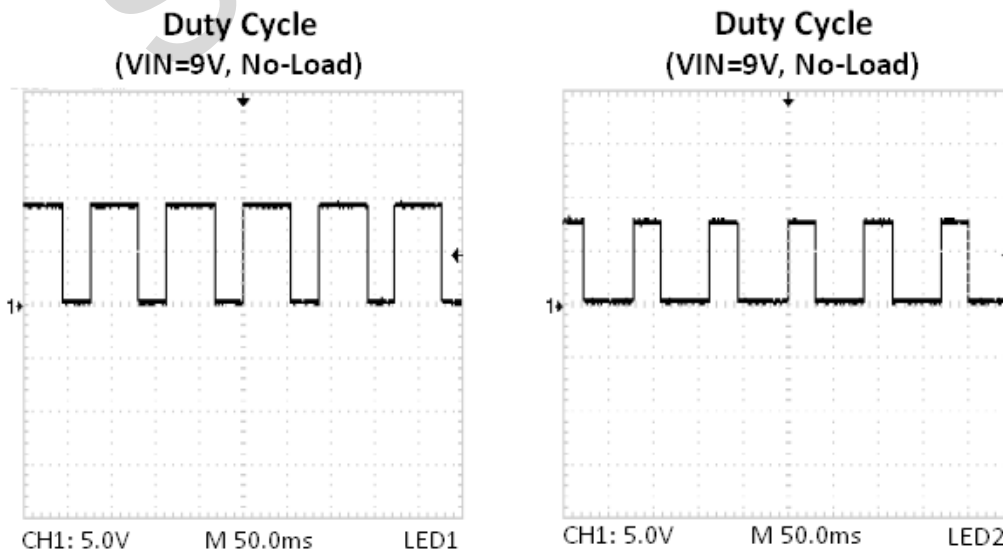

Note1: See right figure for the VCHRG waveform.

Pin Assignment and Description

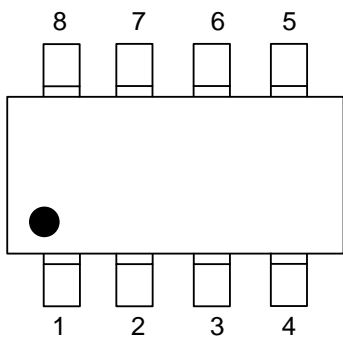
TOP VIEW		PIN	NAME	DESCRIPTION
 <p style="text-align: center;">SOP-8L</p>		1	CHRG1	Open-Drain Charge Status Output
		2	TS	Temperature Sense
		3	GND	Ground
		4	VOUT	Charge Current Output
		5	PDRI	Charge Current Monitor and Shutdown Pin
		6	CS	Charge Current Program
		7	CHRG2	Open-Drain Charge Status Output
		8	VIN	Positive Input Supply Voltage.

Absolute Maximum Ratings (Note 2)

- Input Supply Voltage (VIN) -0.3V ~ 30V
- CS Pin..... -0.3V ~ VIN + 0.3V
- VOOUT Pin Current..... 0.9A
- PD.....2W
- Maximum Junction Temperature +150°C
- Operating Ambient Temperature Range (Note 3).....-40°C ~ +85°C
- Storage Temperature Range-65°C ~ +125°C
- Lead Temperature (Soldering, 10 sec).....+265°C

Note 2: Stresses listed as the above “Absolute Maximum Ratings” may cause permanent damage to the device. Exposure to absolute maximum rating conditions for extended periods may remain possibility to affect device reliability.

Note 3: The GS7001B is guaranteed to meet performance specifications from 0°C to 70°C. Specifications over the -40°C to 85°C operating temperature range are assured by design, characterization and correlation with statistical process controls.

Electrical Characteristics

Operating Conditions: $T_A = 25^\circ\text{C}$, $R_1=R_2=4.7\text{k}$, $R_{TS}=10\text{k}$, $R_{SET}=0.5\Omega$ unless otherwise specified.

SYMBOL	PARAMETER	CONDITIONS	MIN	TYP	MAX	UNITS
V_{IN}	Input Operation Voltage		9		13.5	V
$V_{IN(OVLO)}$	OVLO Threshold	V_{IN} Rising, $V_{BAT}=8\text{V}$		14.2		V
	OVLO Hysteresis			0.4		V
I_Q	Input Supply Current	Standby Mode(No-Load)		4		mA
		$V_{IN}=12\text{V}$, $R_1=R_2=0$		400		μA
I_{SLEEP}	Sleep Current	Sum of currents into VOUT pin, $V_{IN}=0$		25		μA
$\Delta V_{VIN-VBAT}$	Minimum Voltage difference Threshold	$V_{IN}-V_{BAT}$		600		mV
Battery Voltage Regulation Constant-current Charge						
$V_{O(REG)}$	Output Voltage		8.3	8.4	8.48	V
I_{BAT}	BAT Pin Current	$V_{BAT}=8.4\text{V}$		10		μA
$V_{(CS)}$	Current Regulation Threshold	Voltage at pin CS , relative to V_{IN}	180	200	220	mV
Trickle Charge						
V_{TRIKL}	Trickle Charge Threshold Voltage	$V_{BAT} < V_{TRIKL}$, $R_{SET}=0.5\Omega$.		6.3		V
I_{TRIKL}	Trickle Charge Current	V_{BAT} Rising, $R_{SET}=0.5\Omega$.		60		mA
ΔV_{TRIKL}	Trickle Charge Voltage hysteresis			100		mV
Battery Recharge						
$\Delta V_{(RCH)}$	Recharge Battery Voltage hysteresis	$V_{FLOAT} - V_{RECHRG}$		80		mV
CHRG Pin						
I_{CHRG}	CHRG Bias Current			3		mA
Temperature Sense Comparator						
$V_{TS-COLD}$	TS Pin Threshold Voltage (Cold)	V_{TS} from Low to High		2.4		V
V_{TS-HOT}	TS Pin Threshold Voltage (Hot)	V_{TS} from High to Low		0.5		V
I_{TS}	TS Pin Output Current			-80		μA
Thermal Protection						
T_{SD}	Thermal Shutdown	Temperature Rising		150		$^\circ\text{C}$

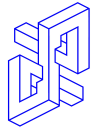

Pin Functions

CHRG1 (Pin 1): Charge Status Indication. When the battery is charging, the CHRG pin is pulled low. When the charge cycle is completed, the CHRG pin is pulled high. This PIN is available through a 2kohm resistor and indicates that the light-emitting diode connected.

TS (Pin 2): Temperature Sense.

GND (Pin 3): Ground.

VOOUT (Pin 4): Charge Current Output. It should be bypassed with at least a 20 μ F capacitor. It provides charge current to the battery and regulates the final float voltage to 8.4V.

PDRI (Pin 5): Driving side. Connect to the grid of the PMOS.

CS (Pin 6): Charge Current Program, Charge Current Monitor and Shutdown Pin. The charge current is programmed by connecting a resistor, R_{SET} , $I_{SET} = V_{(CS)} / R_{SET}$.

CHRG2 (Pin 7): End-of-Charge Status Indication. When the battery is charging, the CHRG2 pin is forced high. When the charge cycle is completed, CHRG2 is pulled low.

VIN (Pin 8): Positive Input Supply Voltage. It Provides power to the charger VIN and should be bypassed with a 20 μ F capacitor.

Application Information

Functional Description

The GS7001B is an advanced 0.9A linear charge controller for dual-cell Li-Ion or Li-Ion applications. Refer to Block Diagram and Operation Flow Chart (Figure 1) in this section.

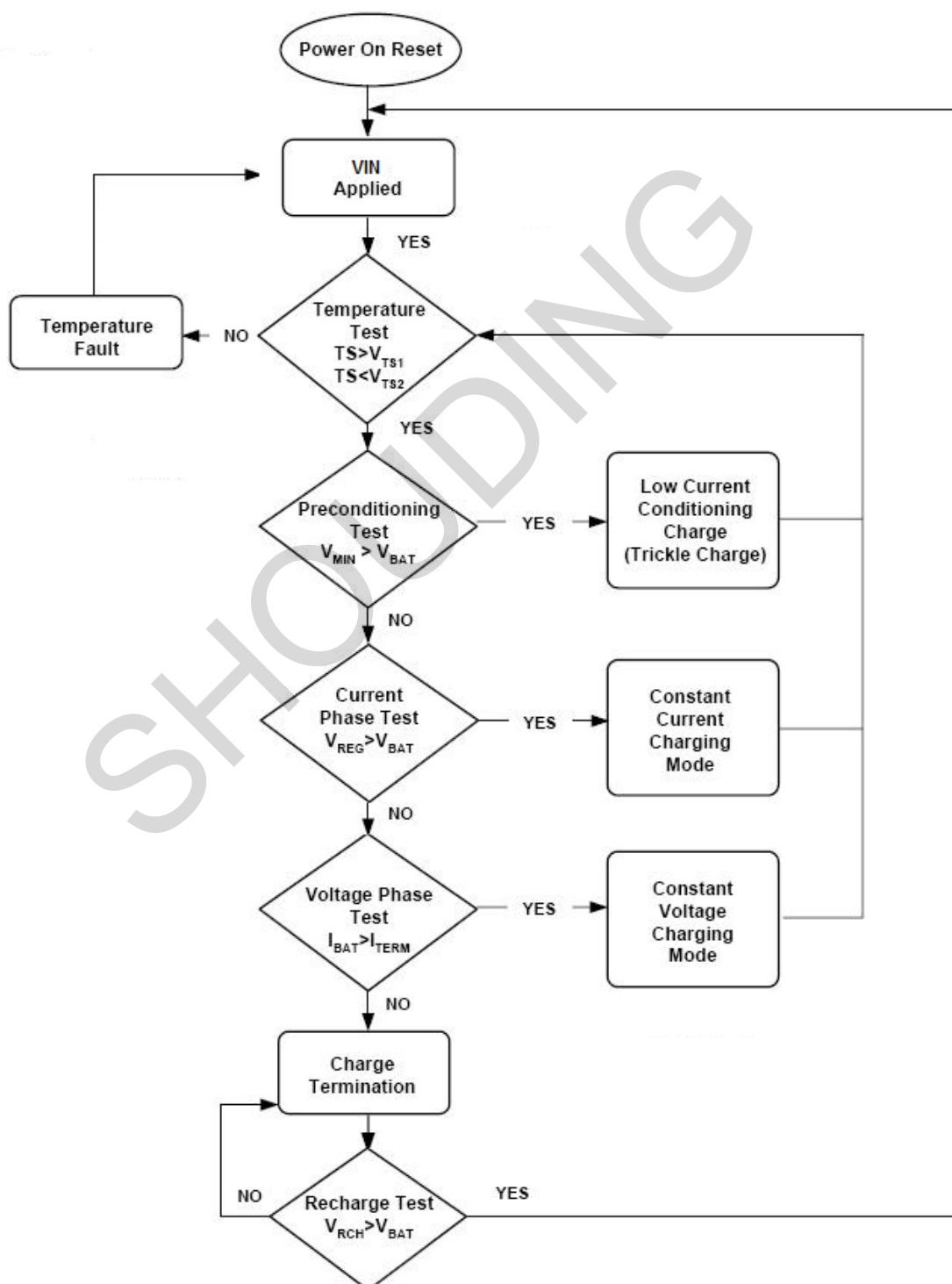

Figure 1: Operation Flow Chart

Qualification and Precharge

When power is applied, the GS7001B starts a charge-cycle if a battery is already present or when a battery is inserted. Charge qualification is based on battery temperature and voltage.

The GS7001B suspends charge if the battery temperature is outside the V_{TS1} to V_{TS2} range and suspends charge until the battery temperature is within the allowed range. The GS7001B also checks the battery voltage. If the battery voltage is below the pre-charge threshold $V_{(min)}$, the GS7001B uses pre-charge to condition the battery. The conditioning charge rate $I_{(PRECHG)}$ is set at approximately 15% of the regulation current. The conditioning current also minimizes heat dissipation in the external pass-element during the initial stage of charge. See Figure 2 for a typical charge-profile.

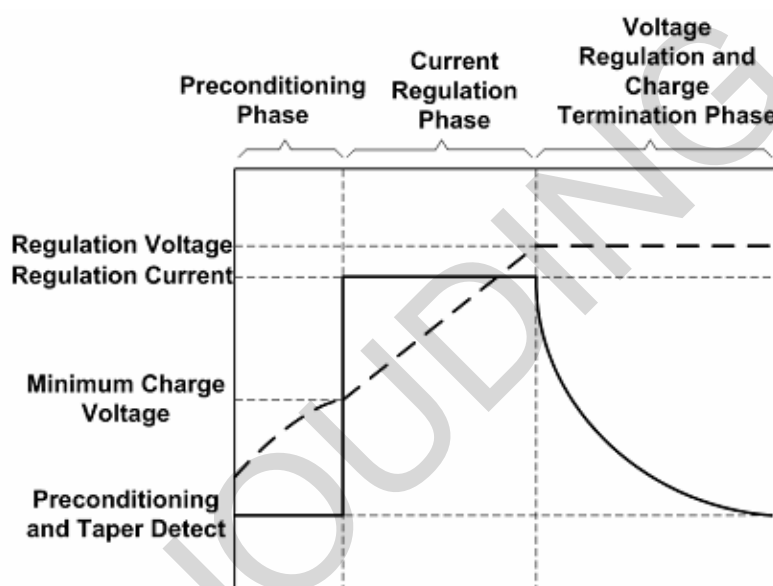

Figure 2: Typical Charge Profile

Current Regulation Phase

The GS7001B regulates current while the battery-pack voltage is less than the regulation voltage, $V_{O(REG)}$. The GS7001B monitors charge current at the CS input by the voltage drop across a sense-resistor, R_{SET} , in series with the battery pack. In current sensing configuration, R_{SET} is between the VIN and CS pins, charge-current feedback, applied through pin CS, maintains a voltage of V_{CS} across the current sense resistor. The following formula calculates the value of the Sense resistor:

$$R_{SET} = \frac{V_{CS}}{I_{O(REG)}}$$

Where, $I_{O(REG)}$ is the desired charging current.

Voltage Phase

The voltage regulation feedback is through the BAT pin. This input is tied directly to the positive side of the battery pack. The GS7001B monitors the battery-pack voltage between the BAT and GND pins. The GS7001B-84 is offered 8.4V output voltage.

Charge Termination Recharge

The GS7001B monitors the charging current during the voltage-regulation phase. The GS7001B declares a done condition and terminates charge when the current drops to the charge termination threshold, I_{TERM} . A new charge cycle begins when the battery voltage falls below the V_{RCH} threshold.

Battery Temperature Monitoring

A negative temperature coefficient (NTC) thermistor located close to the battery pack can be used to monitor battery temperature and will not allow charging unless the battery temperature is within an acceptable range.

Connect a 10k thermistor from the TS pin to ground. With the 80 μ A pull-up current source, the hot temperature voltage threshold is 0.5V. For cold temperature, the voltage threshold is set at 2.4V with 80 μ A of pull-up current. The charge cycle begins or resumes once the temperature is within the acceptable range.

Reverse Blocking Protection

The optional reverse-blocking protection diode, depicted in Figure1 provides protection from a faulted or shorted input, or from a reversed-polarity input source. Without the protection diode, a faulted or shorted input would discharge the battery pack through the body diode of the external pass transistor.

If a reverse-protection diode is incorporated in the design, it should be chosen to handle the fast charge current continuously at the maximum ambient temperature. In addition, the reverse-leakage current of the diode should be kept as small as possible.

Selecting Input Capacitor

In most applications, all that is high-frequency decoupling capacitor. The GS7001B works with both regulated and unregulated external dc supplies. If a non-regulated supply is chosen, the supply voltage to the minimum required input voltage at maximum load. If not, more capacitance must be added to the input of the charger.

Selecting Output Capacitor

The GS7001B does not require any output capacitor for loop stability.

In order to maintain good AC stability in constant Voltage mode, a minimum capacitance of 20 μ F is recommended to bypass the BAT pin to GND. This capacitance provides compensation when there is no battery load. In addition, the battery and interconnections appear inductive at high frequencies. These elements are in the control feedback loop during Constant Voltage mode. Therefore, the bypass capacitance may be necessary to compensate for the inductive nature of the battery pack.

Virtually any good quality output filter capacitor can be used, independent of the capacitor's minimum ESR (Effective Series Resistance) value. The actual value of the capacitor and its associated ESR depends on the forward transconductance (gm) and capacitance of the external pass transistor. A 20 μ F tantalum or aluminum electrolytic capacitor at the output is usually sufficient to ensure stability for up to a 0.9A output current.

PCB Application Suggestions

The temperature characteristic on the sample PCB (Figure3) is showed as follow.

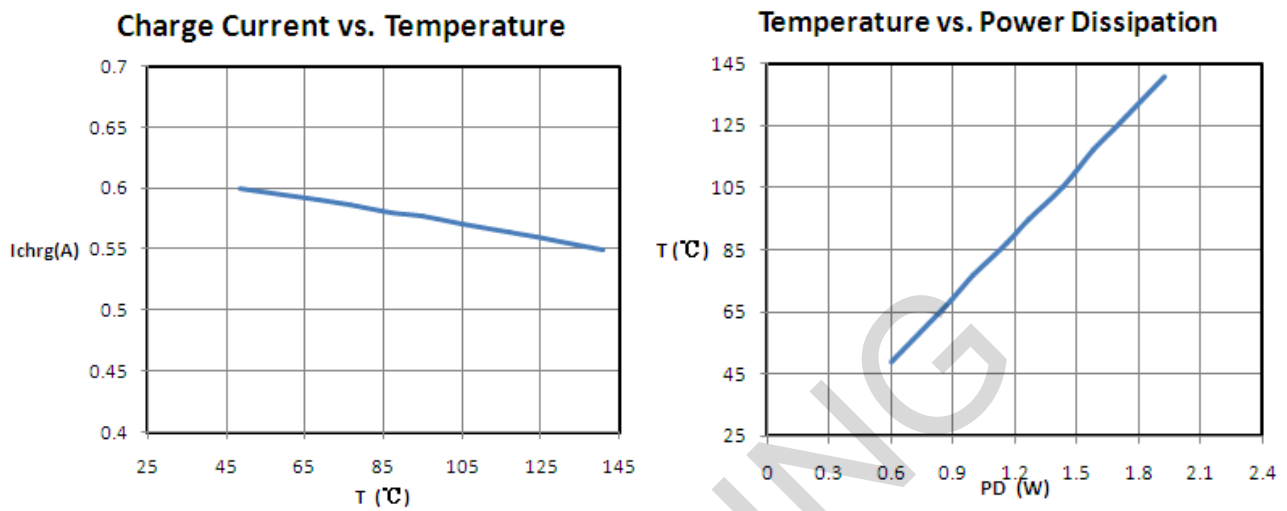
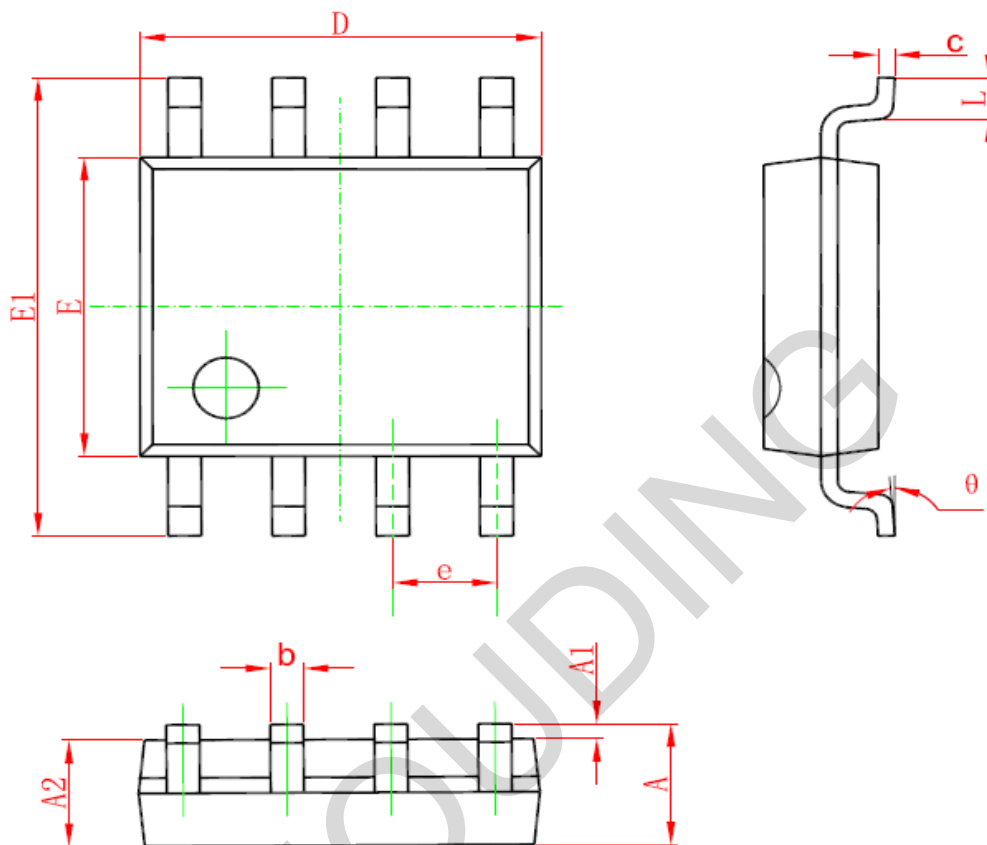

Figure3: Temperature characteristic on the sample PCB



Packaging Information

SOP-8L Package Outline Dimension



Symbol	Dimensions In Millimeters		Dimensions In Inches	
	Min	Max	Min	Max
A	1.350	1.750	0.053	0.069
A1	0.100	0.250	0.004	0.010
A2	1.350	1.550	0.053	0.061
b	0.330	0.510	0.013	0.020
c	0.170	0.250	0.006	0.010
D	4.700	5.100	0.185	0.200
E	3.800	4.000	0.150	0.157
E1	5.800	6.200	0.228	0.244
e	1.270(BSC)		0.050(BSC)	
L	0.400	1.270	0.016	0.050
θ	0°	8°	0°	8°

X-ON Electronics

Largest Supplier of Electrical and Electronic Components

Click to view similar products for [Battery Management](#) category:

Click to view products by [SHOUDING](#) manufacturer:

Other Similar products are found below :

[NCP1851BFCCT1G](#) [NCP1855FCCT1G](#) [FAN54063UCX](#) [MP2615GQ-P](#) [LC05132C01NMTTTG](#) [ISL95522HRZ](#) [BD8665GW-E2](#)
[ISL95522AIRZ](#) [S-82D1AAE-A8T2U7](#) [S-82D1AAA-A8T2U7](#) [S-8224ABA-I8T1U](#) [MP2615CGQ-P](#) [ISL6251HRZ](#) [ISL6253HRZ](#) [ISL6292-2CR3](#) [ISL6292BCRZ-T](#) [ISL6299AIRZ](#) [ISL9211AIRU58XZ-T](#) [ISL9214IRZ](#) [ISL9220IRTZ-T](#) [FAN54161UCX](#) [DW01-A/J](#) [DW01A](#) [4056H](#)
[4056D](#) [TP4056](#) [TP4054](#) [TP4057](#) [IP2326_NPD](#) [IP2709_BF20WP](#) [TP4057](#) [TP4054](#) [TP4056-MS](#) [TP4057-MS](#) [TP4054-MS](#) [SY6982CQDC](#)
[SLM6335](#) [SLM6500S](#) [TP4057](#) [DW01](#) [AP5056HSPER](#) [EG4321](#) [GN4054B](#) [HG4054M5/TR](#) [4060](#) [4061](#) [4061H](#) [4056A](#) [4056V](#) [4060H](#)