



Features

- Simple low parts count
- Internal 40V NDMOS switch
- 1A output current
- Single pin on/off and brightness control Using DC voltage or PWM
- Soft-start
- High efficiency (up to 97%)
- Wide input voltage range: 6V to 40V
- Output shutdown
- Open LED Protection
- Short LED Protection
- Up to 1MHz switching frequency
- Inherent open-circuit LED protection
- Typical 5% output current accuracy
- Pb-free SOT23-5 and SOT89-5 Packages

Applications

- Low voltage halogen replacement LEDs
- Low voltage industrial lighting
- LED back-side lighting
- Illuminated signs

Description

The SD3361 is a continuous mode inductive step-down converter, designed for driving single or multiple series connected LEDs efficiently from a voltage source higher than the LED voltage. The device operates from an input supply between 6V and 40V and provides an externally adjustable output current of up to 1A. Depending upon supply voltage and external components, this can provide up to 30 watts of output power.

The SD3361 1 includes the output switch and a high-side output current sensing circuit, which uses an external resistor to set the nominal average output current.

Output current can be adjusted below the set value, by applying an external control signal to the VSET pin.

The VSET pin will accept either a DC voltage or a PWM waveform.

The soft-start time can be increased using an external capacitor from the VSET pin to ground. Applying a voltage of 0.2V or lower to the VSET pin turns the output off and switches the device into a low current standby state.

Typical Application

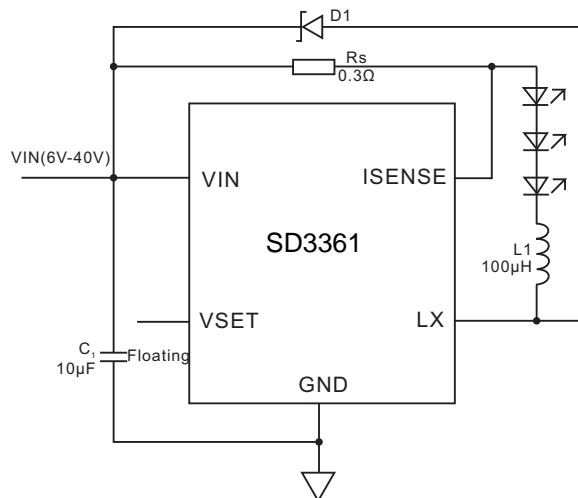



Block Diagram

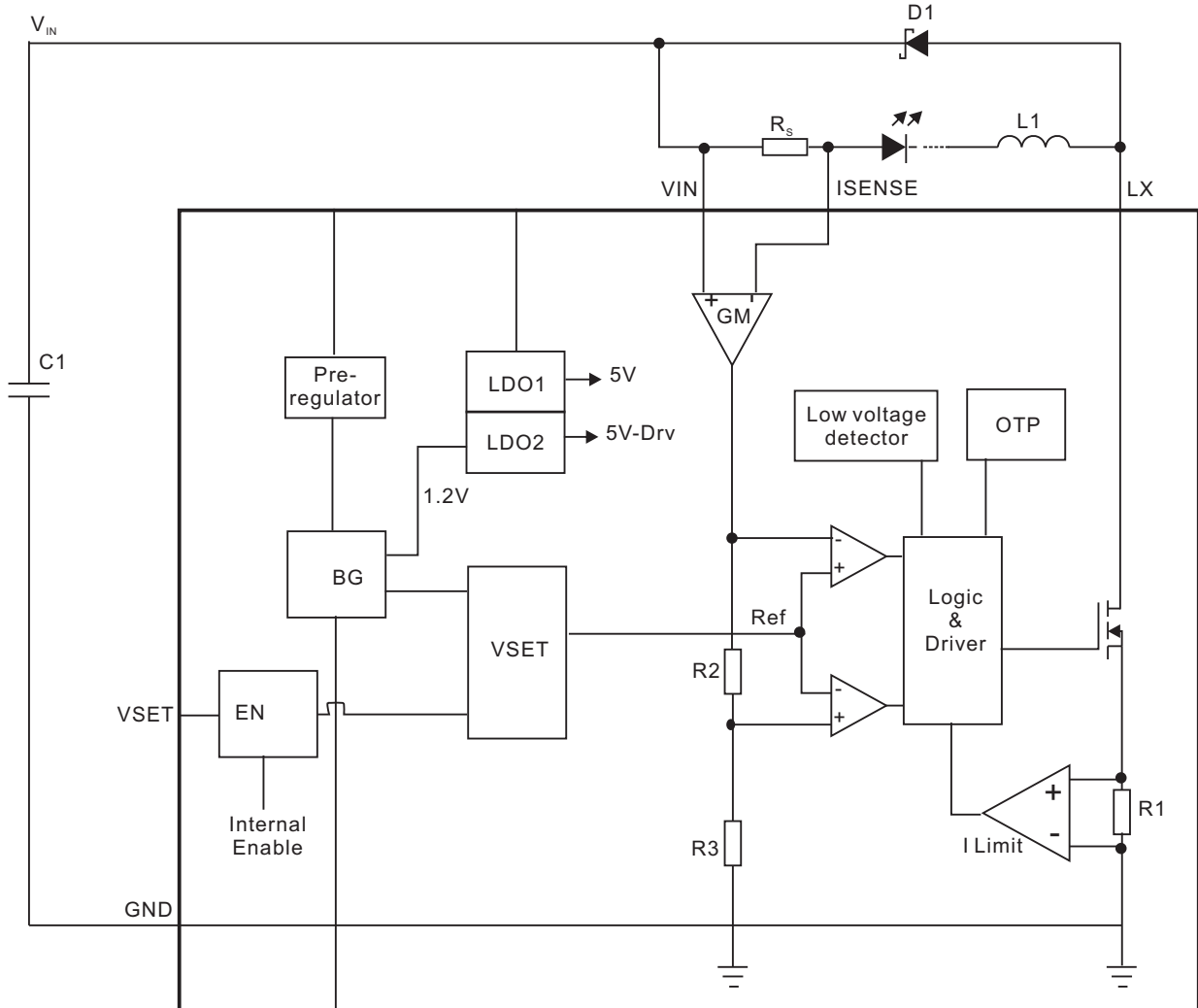



Pin Configuration

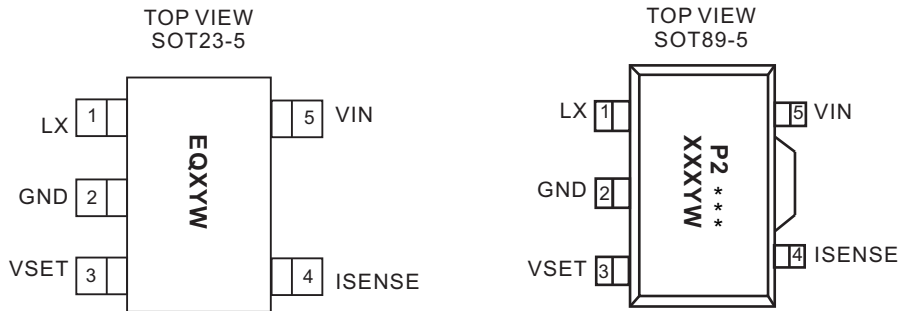

EQ: Product Code of SD3361
 X: Internal Code
 Y: Year
 W: Week

Pin Descriptions

Pin Number	Name	Description
SOT23-5/ SOT89-5		
1	LX	Drain of NDMOS switch.
2	GND	Ground (0V)
3	VSET	<ul style="list-style-type: none"> Multi-function On/Off and brightness control pin: Leave floating for normal operation. Drive to voltage below 0.2V to turn off output current Drive with DC voltage (0.3V < VSET < 2.5V) to adjust output current from 12% to 100% of I_{OUT}nom Drive with PWM signal from open-collector or open-drain transistor, to adjust output current. Adjustment range 1% to 100% of I_{OUT}nom for f < 500Hz Connect a capacitor from this pin to ground to increase soft-start time. (Default soft-start time = 0.1ms. Additional soft-start time is approx. 1.5ms/1nF)
4	ISENSE	Connect resistor R _S from this pin to VIN to define nominal average output current I _{OUT} nom = 0.1/R _S
5	VIN	Input voltage (6V to 40V). Decouple to ground with 10μF or higher X7R ceramic capacitor close to device.



Absolute Maximum Ratings

These are stress ratings only and functional operation is not implied. Exposure to absolute maximum ratings for prolonged time periods may affect device reliability. All voltages are with respect to ground.

Input Voltage Range.....	-0.3V to 40V	Maximum Junction Temperature.....	170°C
LX, ISENSE Pin voltage.....	-0.3V to 40V	Storage Temperature.....	-65°C to 170°C
VSET Pin voltage.....	-0.3V to 6V	Soldering Temperature.....	300°C, 5sec

Recommended Operating Conditions

Input Voltage Range.....	6V to 40V	Ambient Temperature Range.....	-40°C to 85°C
		Junction Temperature Range.....	-40°C to 150°C

Thermal Information

Parameter	Package	Symbol	Maximum	Unit
Thermal Resistance (Junction to Ambient)	SOT23-5	θ_{JA}	250	°C/W
	SOT89-5		160	
Thermal Resistance (Junction to Case)	SOT23-5	θ_{JC}	130	
	SOT89-5		45	

**Electrical Characteristic**T_A=25°C, V_{IN}=16V, unless otherwise noted.

Parameter	Symbol	Condition	Min	Typ	Max	Units
Input voltage	V _{in}		6		40	V
Output current	I _{LED}	R _S =0.3Ω		333		mA
		R _S =0.1Ω		1		A
Shutdown current	I _{SD}	VSET pin grounded		20	40	μA
Quiescent current without switching	I _Q	VSET pin floating, V _{in} =16V		0.6		mA
Mean current sense threshold voltage	V _{sense}	Measured on I _{sense} pin with respect to V _{IN}	95	100	105	mV
Sense threshold hysteresis	V _{sense_hys}			±13		%
I _{sense} pin input current	I _{sense}	V _{sense} = V _{in} – 0.1		8		μA
Vset range on VSET pin	V _{en}	For DC dimming	0.3		2.5	V
DC voltage on VSET pin to enable	V _{enon}	V _{en} rising		0.25		V
DC voltage on VSET pin to disable	V _{enoff}	V _{en} falling		0.2		V
LX switch on resistance	R _{LX}	@I _{LX} =100mA		0.3		Ω
LX switch leakage current	I _{LX(leak)}				5	μA
Soft start time	T _{ss}	V _{in} =16V, C _{en} = 1nF		1.5		ms
Operating frequency	F _{LX}	V _i =16V, V _o =9.6V (3 LEDS), L=47μH, ΔI=0.25A (I _{LED} =1A)		233		kHz
Recommended minimum switch ON time	T _{on_rec}	For 4% accuracy		500		ns
Recommended maximum switch frequency	F _{LXmax}				1.0	MHz
Max duty circle				98		%
Recommended duty cycle range	D _{LX}		25		75	%
Internal comparator propagation delay	T _{PD} *			45		ns
Over temperature protection	T _{OTP}			150		°C
Temp protection hysteresis	T _{OTP_hys}			40		°C
Current limit	I _{XLmax}	Peak inductor current	1.5			A

*parameters are not tested at production, but guaranteed by design.

Note: V_{sense}: level A: 95mV to 100mV; level B: 100mV to 105mV

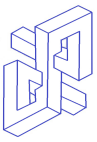

Typical Operating Characteristics

T_A=25°C, V_{IN}=16V, unless otherwise noted.

1. Efficiency vs Input Voltage (Rs=0.3Ω, L=100μH)

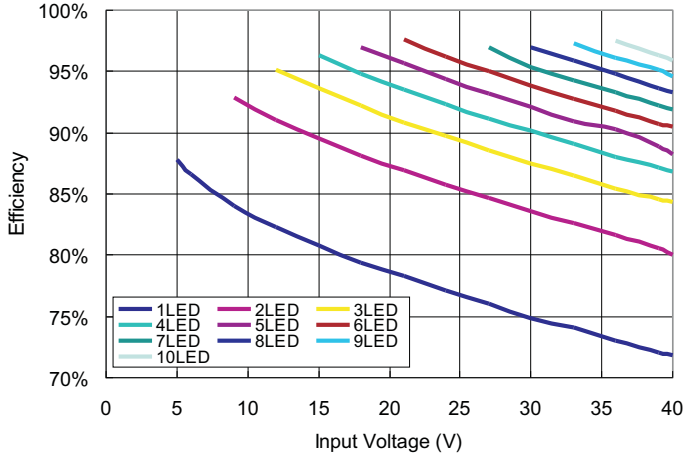

2. Efficiency vs Input Voltage (Rs=0.15Ω, L=47μH)

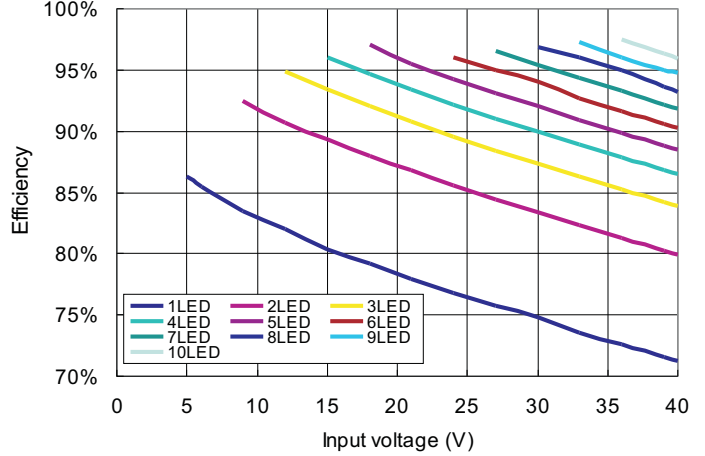

3. Efficiency vs Input Voltage (Rs=0.1Ω, L=33μH)

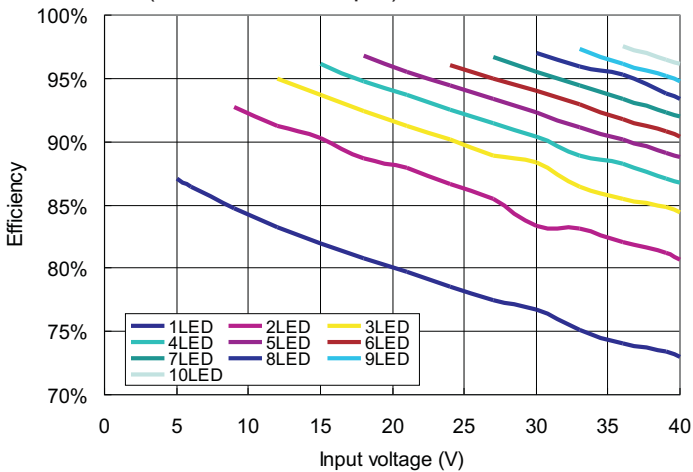

4. Operating Frequency vs Input Voltage (Rs=0.3Ω, L=100μH)

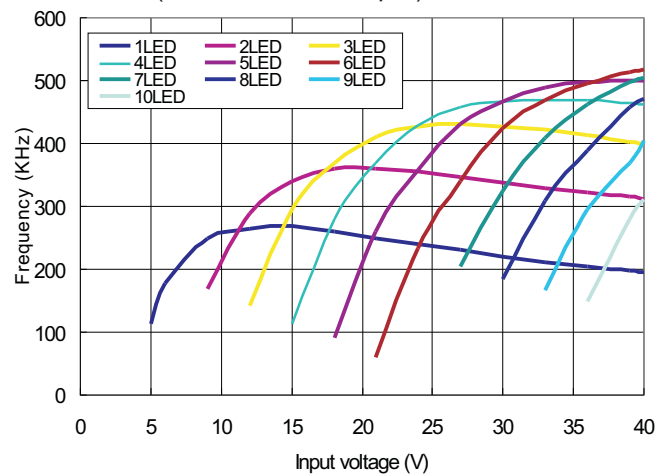

5. Operating Frequency vs Input Voltage (Rs=0.15Ω, L=47μH)

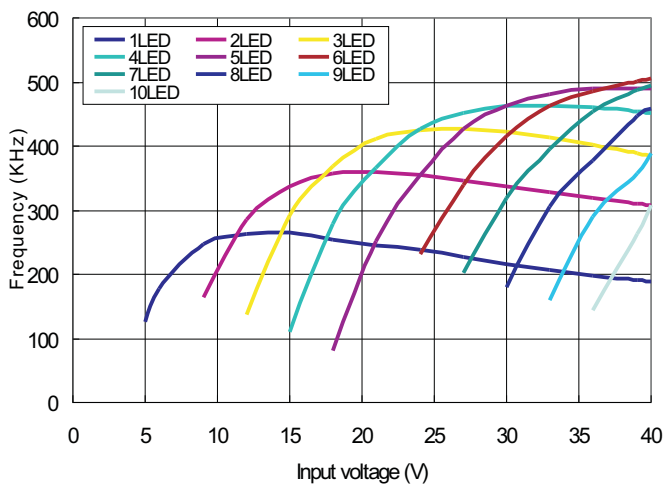

6. Operating Frequency vs Input Voltage (Rs=0.1Ω, L=33μH)

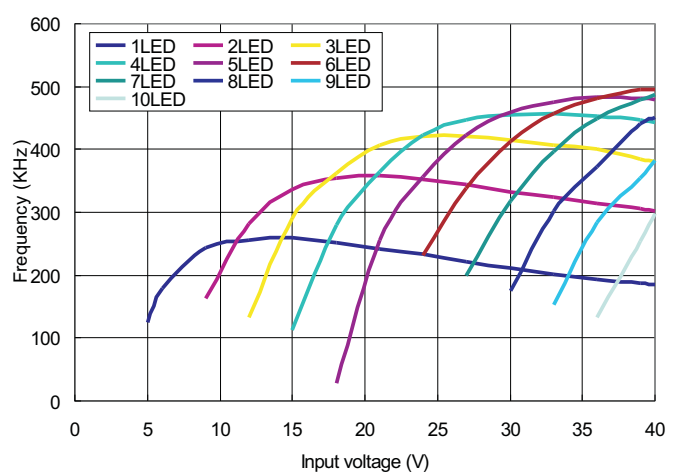



Typical Operating Characteristics

$T_A=25^{\circ}\text{C}, V_{IN}=16\text{V}$, unless otherwise noted.

7. Quiescent Current VS. Input Voltage

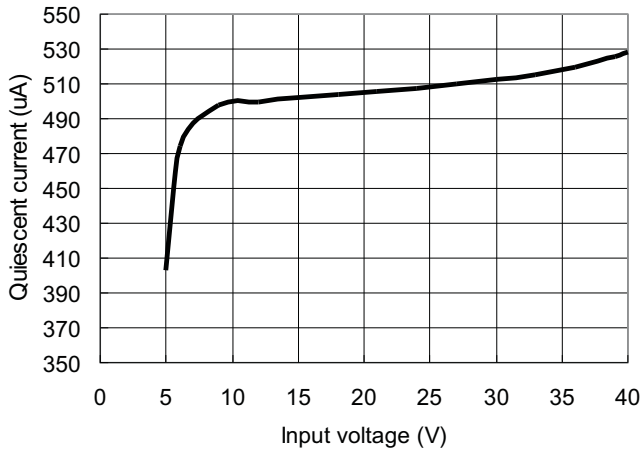

8. Shutdown Current VS. Input Voltage

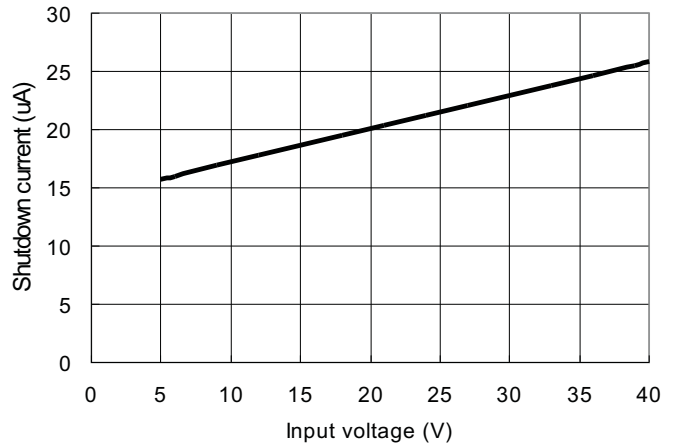

9. Feedback Voltage VS Vin

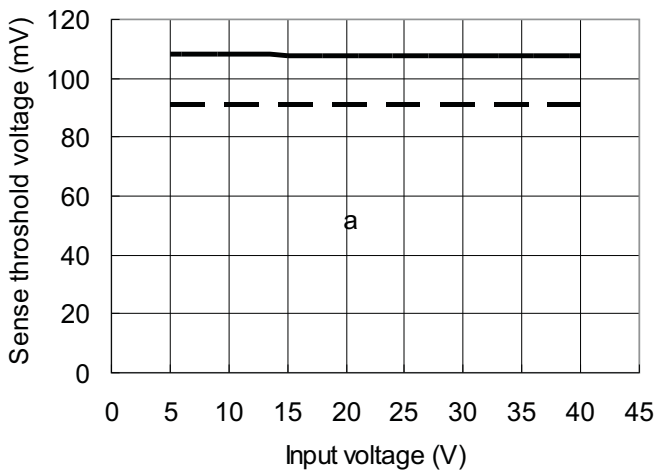

10. Duty Cycle VS LED Current (PWM=200Hz)

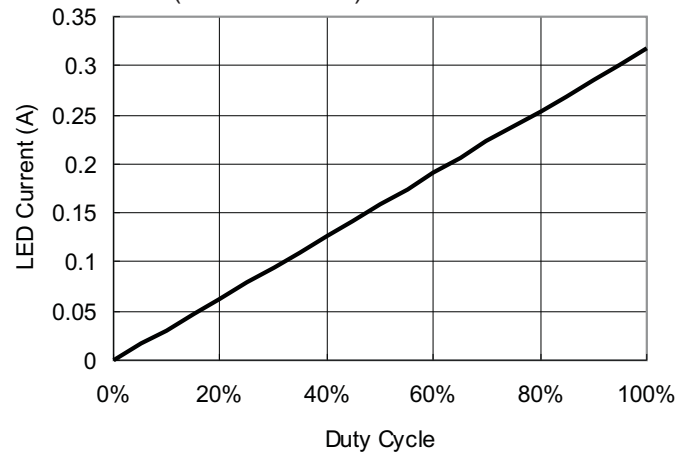

11. I_{LED} vs V_{SET} ($V_{IN}=16\text{V}$, 3 LEDs, $100\mu\text{H}$, $R_s=0.3\Omega$)

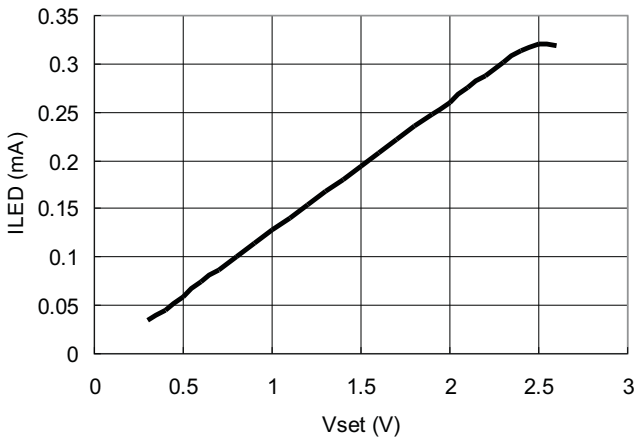

12. I_{LED} vs V_{SET} ($V_{IN}=16\text{V}$, 3 LEDs, $47\mu\text{H}$, $R_s=0.15\Omega$)

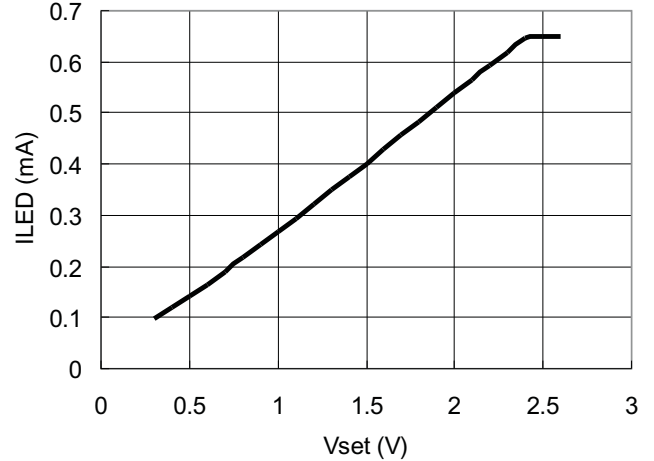



Typical Operating Characteristics

$T_A=25^{\circ}\text{C}, V_{IN}=16\text{V}$, unless otherwise noted.

13. Steady State Waveforms



14. Start up Waveforms

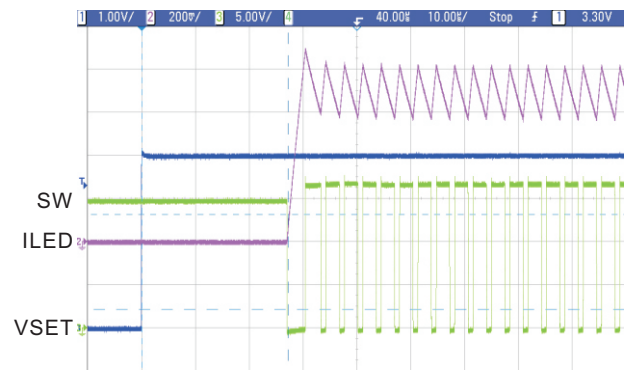

15. Dimming Waveforms (PWM=50%)

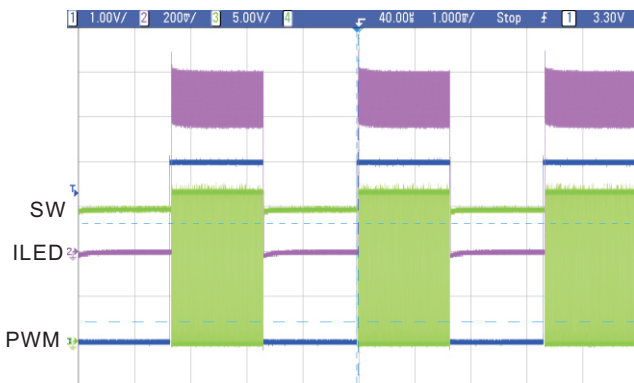

16. Pulse skip mode

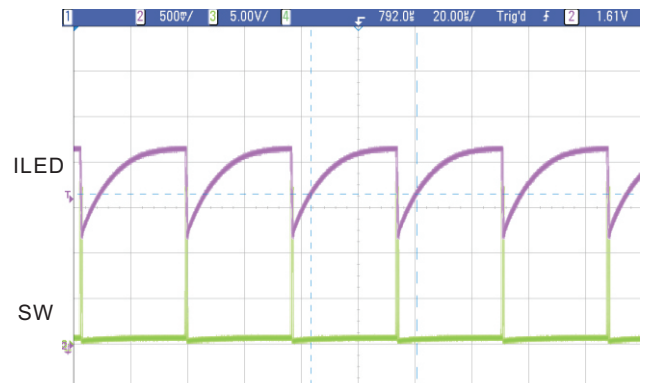

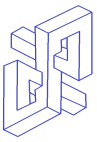

Application Information

Setting nominal average output current with external resistor R_s

The nominal average output current in the LED(s) is determined by the value of the external current sense resistor (R_s) connected between VIN and ISENSE and is given by:

$$I_{OUTnom} = \frac{0.1}{R_s}$$

The table below gives values of nominal average output current for several preferred values of current setting resistor (R_s) in the typical application circuit shown on page 1.

R _s (Ω)	Nominal average output current (mA)
0.1	1000
0.13	760
0.15	667
0.3	333

The above values assume that the VSET pin is floating and at a nominal voltage of VREF (1.25V). Note that R_s = 0.1Ω is the minimum allowed value of sense resistor under these conditions to maintain switch current below the specified maximum value. It is possible to use different values of R_s if the VSET pin is driven from an external voltage.

Capacitor selection

A low ESR capacitor should be used for input decoupling, as the ESR of this capacitor appears in series with the supply source impedance and lowers overall efficiency. This capacitor has to supply the relatively high peak current to the coil and smooth the current ripple on the input supply. A minimum value of 4.7μF is acceptable if the input source is close to the device, but higher values will improve performance at lower input voltages, especially when the source impedance is high. The input capacitor should be placed as close as possible to the IC.

For maximum stability over temperature and voltage, capacitors with X7R, X5R, or better dielectric are recommended. Capacitors with Y5V dielectric are not suitable for decoupling in this application and should NOT be used.

Inductor selection

Recommended inductor values for the SD3361 are in the range 33μH to 100μH. Higher values of inductance are recommended at higher supply voltages in order to minimize errors due to switching delays, which result in increased ripple and lower efficiency. Higher values of inductance also result in a smaller change in output current

over the supply voltage range. The inductor should be mounted as close to the device as possible with low resistance connections to the LX and VIN pins. The chosen coil should have a saturation current higher than the peak output current and a continuous current rating above the required mean output current.

The inductor value should be chosen to maintain operating duty cycle and switch 'on'/'off' times within the specified limits over the supply voltage and load current range. The following equations can be used as a guide.

LX Switch 'On' time

$$T_{ON} = \frac{L\Delta I}{V_{IN} - V_{LED} - I_{LED}(R_s + R_L + R_{LX})}$$

LX Switch 'Off' time

$$T_{OFF} = \frac{L\Delta I}{V_{LED} + V_D + I_{LED}(R_s + R_L)}$$

Where: L is the coil inductance; R_L is the coil resistance ; R_s is the current sense resistance I_{LED} is the required LED current; ΔI is the coil peak-peak ripple current (Internally set to 0.25 x I_{LED}); V_{IN} is the supply voltage; V_{LED} is the total LED forward voltage; R_{LX} is the switch resistance (0.3Ω nominal); V_D is the diode forward voltage at the required load current.

Diode selection

For maximum efficiency and performance, the rectifier (D1) should be a fast low capacitance Schottky diode with low reverse leakage at the maximum operating voltage and temperature. They also provide better efficiency than silicon diodes, due to a combination of lower forward voltage and reduced recovery time.

It is important to select parts with a peak current rating above the peak coil current and a continuous current rating higher than the maximum output load current. It is very important to consider the reverse leakage of the diode when operating above 85°C. Excess leakage will increase the power dissipation in the device and if close to the load may create a thermal runaway condition.

The higher forward voltage and overshoot due to reverse recovery time in silicon diodes will increase the peak voltage on the LX output. If a silicon diode is used, care should be taken to ensure that the total voltage appearing on the LX pin including supply ripple, does not exceed the specified maximum value.

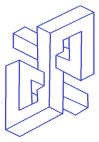

Ordering Information

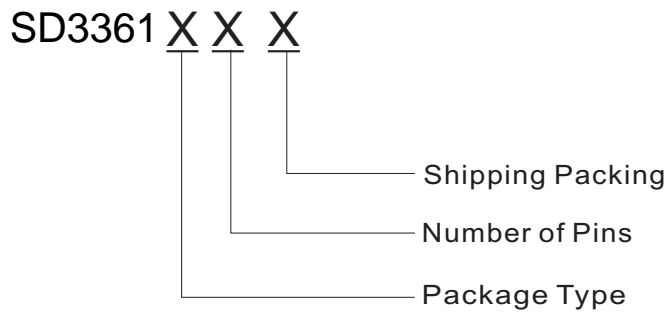

Package Type	Number of pins
A: SOT23 C: SOT89	B: 5

Part Number	Marking	Package Type	MOQ/ Packing
SD3361 ABR	EQXYW	SOT23-5	3,000 Units/ Tape & Reel
SD3361 CBR	P2 * * * XXXYW	SOT89-5	1,000 Units/ Tape & Reel



Outline Dimensions

SOT23-5

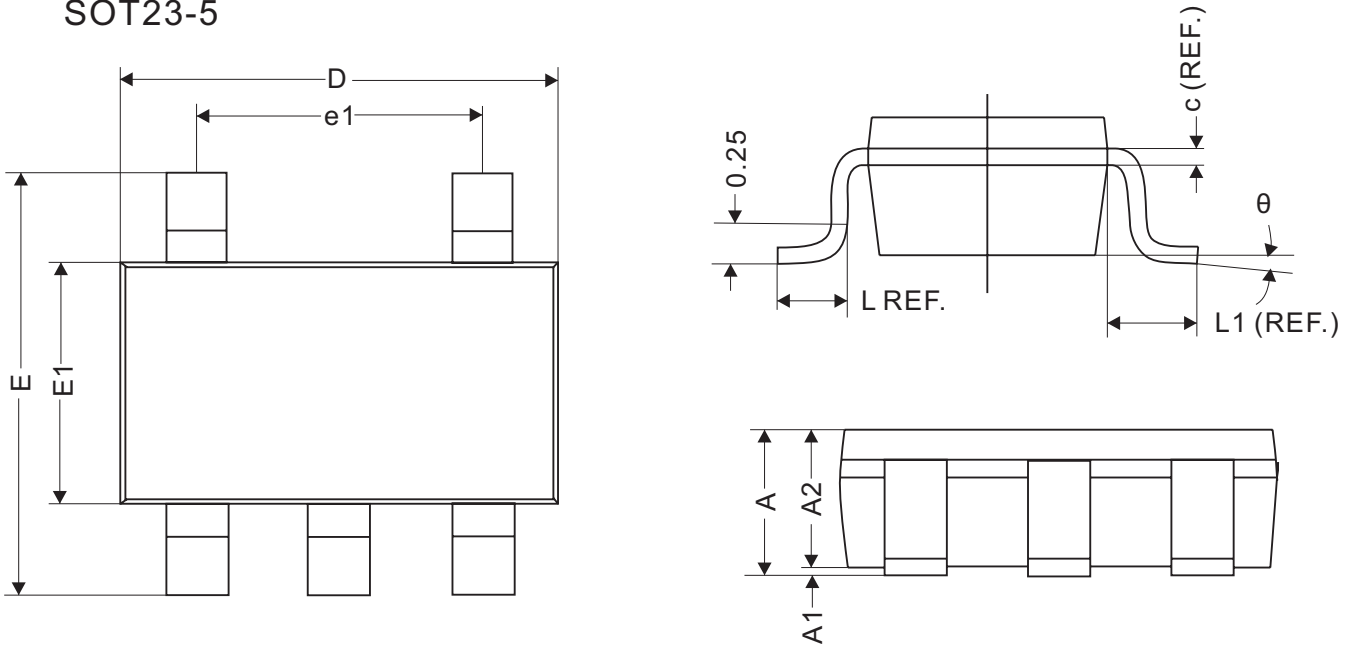

REF.	Millimeter		
	Min	Nom	Max
A	1.10MAX		
A1	0	0.05	0.10
A2	0.70	1.00	1.295
c	0.12REF.		
D	2.70	2.90	3.10
E	2.60	2.80	3.00
E1	1.40	1.60	1.80
L	0.45REF.		
L1	0.60REF.		
θ	0°	5°	10°
b	0.30	0.40	0.50
e	0.95REF.		
e1	1.90REF.		

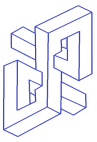

Outline Dimensions

SOT89-5

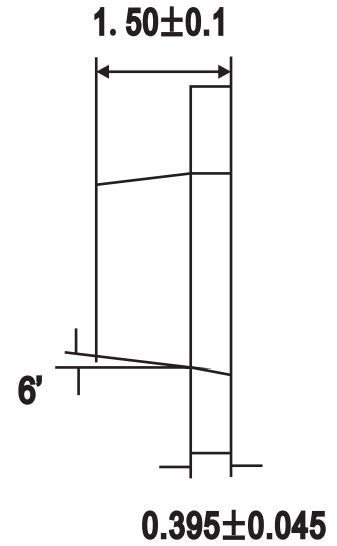
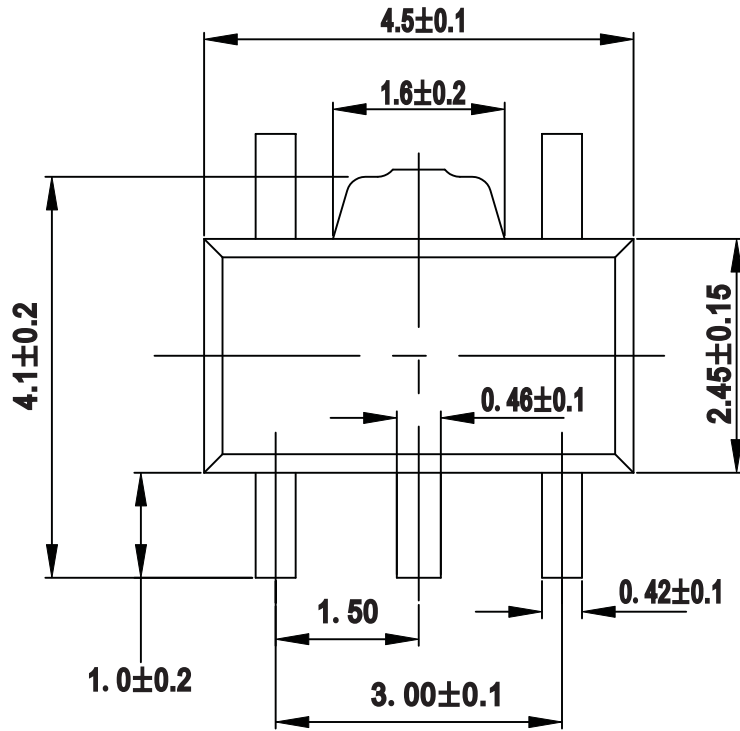

(Unit: mm)

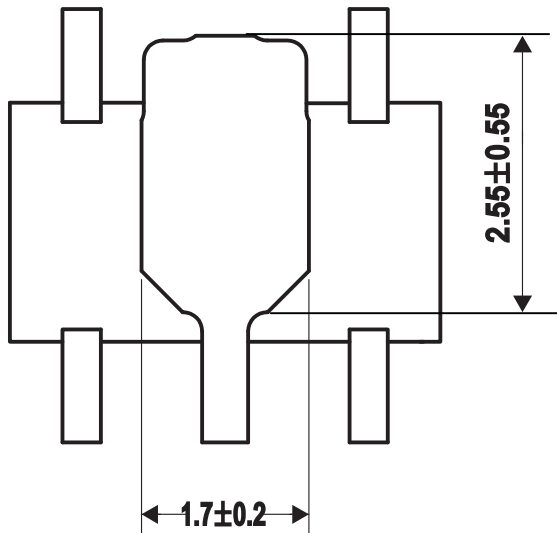

Bottom View

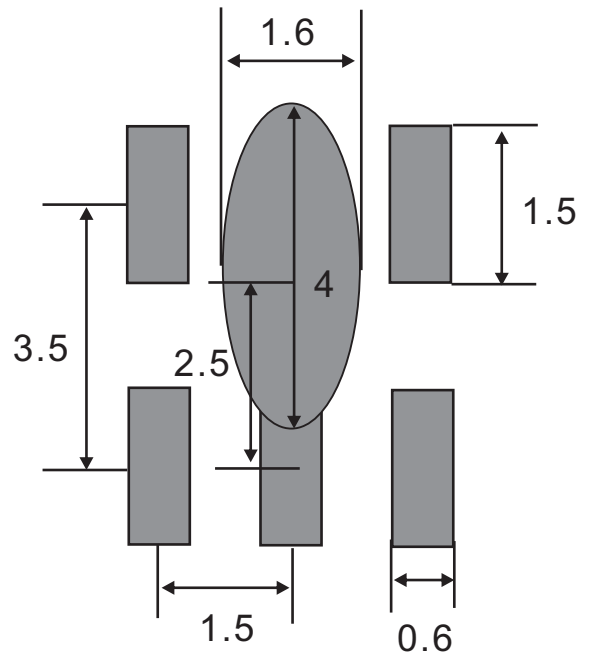

Recommended Land Pattern

X-ON Electronics

Largest Supplier of Electrical and Electronic Components

Click to view similar products for [LED Display Drivers](#) category:

Click to view products by [SHOUDING](#) manufacturer:

Other Similar products are found below :

[MAP9000QNRH](#) [AP5726WUG-7](#) [AL8806QMP-13](#) [AP5726FDCG-7](#) [AS3693B-ZTQT](#) [AP5725WUG-7](#) [MAX139EQH+D](#) [STP16DP05PTR](#)
[STP16CPP05PTR](#) [STP16CPP05XTTR](#) [LV5236VZ-TLM-H](#) [BP9911CC](#) [ZXLD1366QEN8TC](#) [MT7725D](#) [TX6143](#) [SY6813PEC](#) [SD1002L4](#)
[AW3643CSR](#) [MP3370GN-Z](#) [LA2284L-G09-T](#) [SEDA](#) [SCT2027CSSG](#) [LYT3315D](#) [LYT3324D](#) [LYT4211E2](#) [LYT4214E2](#) [LYT4215E2](#)
[LYT4217E2](#) [LYT4218E2](#) [LYT4222E](#) [LYT4317E2](#) [LYT4321E](#) [LYT4323E](#) [LYT4324E3](#) [LYT4326E3](#) [TPS92020DR](#) [TPS92691PWPR](#)
[BCR420U](#) [HV9801ALG-G](#) [IS31FL3199-QFLS2-TR](#) [IS31FL3731-QFLS2-TR](#) [CAT4238TD](#) [SCT2001ASIG](#) [SCT2024CSTG](#) [SCT2167CSOG](#)
[SCT2167CSSG](#) [STP16CPPS05XTTR](#) [TLE4241GMFUMA1](#) [ICM7212MIQH+D](#) [ICM7212AIQH+D](#)