



■ General Description

The SD3362 is a step-down DC/DC converter designed to drive LEDs with a constant current. The device can drive up to 8 LEDs, depending on the forward voltage of the LEDs, in series from a voltage source of 6V to 30V. Series connection of the LEDs provides identical LED currents resulting in uniform brightness and eliminating the need for ballast resistors. The SD3362 switches at frequency up to 1MHz. This allows the use of small size external components, hence minimizing the PCB area needed.

Maximum output current of SD3362 is set via an external resistor connected between the VIN and SET input pins. Dimming is achieved by applying either a DC voltage or a PWM signal at the CTRL input pin. An input voltage of 0.4V or lower at CTRL switches off the output MOSFET simplifying PWM dimming.

■ Features

- LED driving current up to 1A
- Better than 5% accuracy
- High efficiency up to 98%
- Operating input voltage from 6V to 30V
- High switching frequency up to 1MHz
- PWM/DC input for dimming control
- Built-in output open-circuit protection

■ Applications

- MR 16 lamps
- General illumination lamps

■ Pin Configuration

SOT23-5L

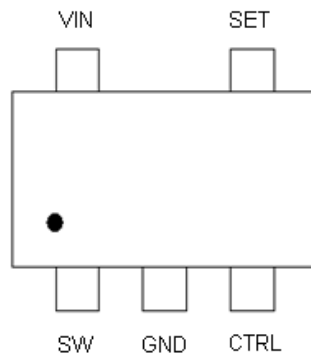

Pin Name	Pin No.	Pin Function
SW	1	Switch Pin. Connect inductor/freewheeling diode here, minimizing track length at this pin to reduce EMI.
GND	2	GND Pin
CTRL	3	Dimming and On/Off Control Input.
SET	4	Set Nominal Output Current Pin. Configure the output current of the device.
Vin	5	Input Supply Pin.



■ Typical Application Circuit

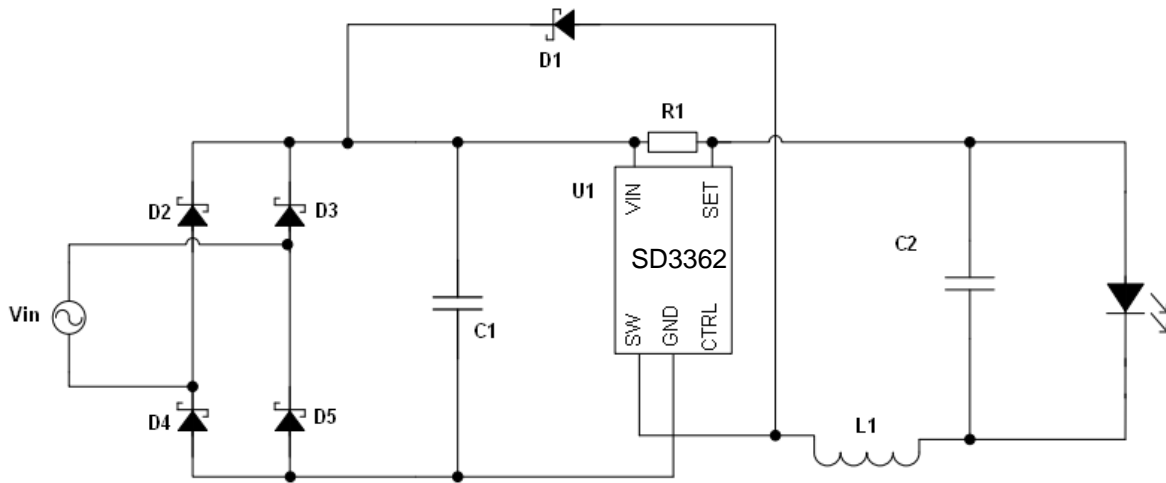

■ Absolute Maximum Ratings

Parameter	Symbol	Rating	Unit
Continuous pin voltage relative to GND	VIN	-0.3~36	V
SW voltage relative to GND	VSW	-0.3~36	V
CTRL pin input voltage	VCRTL	-0.3~6	V
DC or RMS Switch current	ISW-DC	1.25	A
Peak Switch current (<10%)	ISW-PK	2.5	A
Junction Temperature	TJ	150	°C
Lead Temperature Soldering	TLEAD	300	°C
Storage Temperature Range	TST	-65 to +150	°C

**Caution:** Stresses greater than the 'Absolute Maximum Ratings' specified above, may cause permanent damage to the device. These are stress ratings only; functional operation of the device at these or any other conditions exceeding those indicated in this specification is not implied. Device reliability may be affected by exposure to absolute maximum rating conditions for extended periods of time.

Semiconductor devices are ESD sensitive and may be damaged by exposure to ESD events. Suitable ESD precautions should be taken when handling and transporting these devices.



### ■ Electrical Characteristics

V<sub>IN</sub> =12V, T<sub>A</sub>=25°C, unless otherwise specified.

Symbol	Parameter	Conditions	Min.	Typ.	Max.	Unit.
V <sub>INSU</sub>	Internal regulator start up threshold	V <sub>IN</sub> rising	-	-	5.9	V
V <sub>INSH</sub>	Internal regulator hysteresis threshold	V <sub>IN</sub> falling	100	-	300	mV
I <sub>Q</sub>	Quiescent current	Output not switching(Note 2)	-	-	350	μA
I <sub>S</sub>	Input supply Current	C <sub>TRL</sub> pin floating f = 250kHz		1.8	5	mA
V <sub>TH</sub>	Set current Threshold Voltage		95	100	105	mV
V <sub>TH-H</sub>	Set threshold hysteresis		-	±20		mV
I <sub>SET</sub>	SET pin input current	V <sub>SET</sub> = V <sub>IN</sub> -0.1	-	16	22	μA
R <sub>CTRL</sub>	C <sub>TRL</sub> pin input resistance	Referred to internal reference	-	50	-	kΩ
V <sub>REF</sub>	Internal Reference Voltage		-	2.5	-	V
R <sub>DS(on)</sub>	On Resistance of SW MOSFET	I <sub>SW</sub> = 1A	-	0.25	0.4	Ω
I <sub>SW_Leakage</sub>	Switch leakage current	V <sub>IN</sub> =30V	-	0.5	-	μA
f <sub>OSC</sub>	Switching Frequency		-	1	-	MHz
θ <sub>JA</sub>	Thermal Resistance Junction-to-Ambient	SOT23-5 (Note 3)	-	250	-	°C/W
ψ <sub>JB</sub>	Thermal resistance junction-to-lead(Note 4)	SOT23-5	-	250	-	

**Notes:** 2. SD3362 does not have a low power standby mode but current consumption is reduced when output switch is inhibited: V<sub>SENSE</sub> = 0V. Parameter is tested with V<sub>CTRL</sub> ≤ 2.5V

3. Test condition for SOT23-5: Device mounted on FR-4 PCB (25mm x 25mm 1oz copper, minimum recommended pad layout on top layer and thermal vias to bottom layer ground plane. For better thermal performance, larger copper pad for heat-sink is needed.
4. As SOT23-5L doesn't have an exposed tab or exposed pad the majority of heat flow is through pin 2 down to ground.



Typical Characteristics

(TA = 25°C unless otherwise stated)

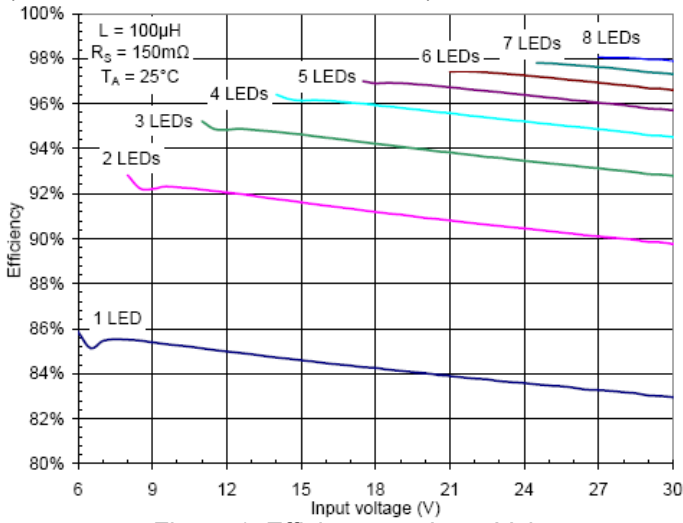

Figure 1, Efficiency vs. Input Voltage

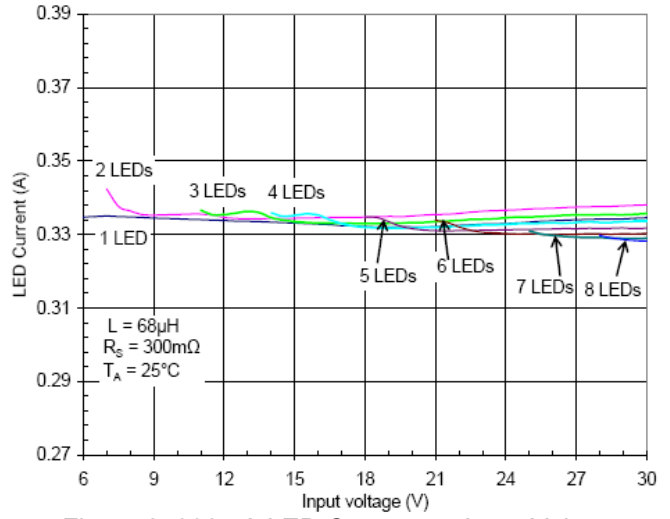

Figure 2, 330mA LED Current vs. Input Voltage

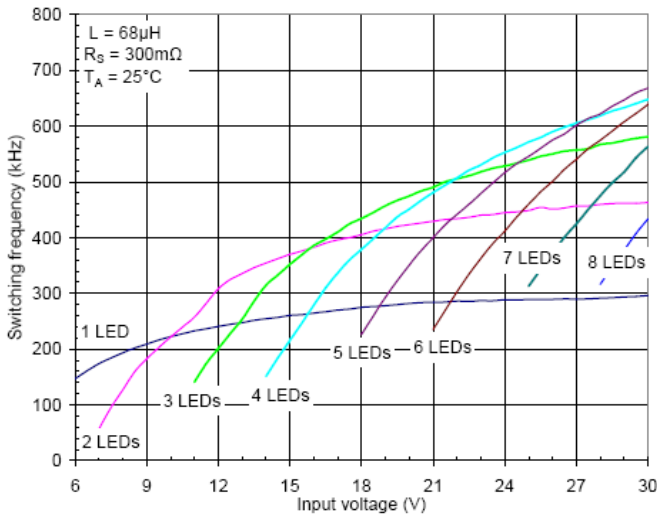

Figure 3, Switching Frequency vs. Input Voltage

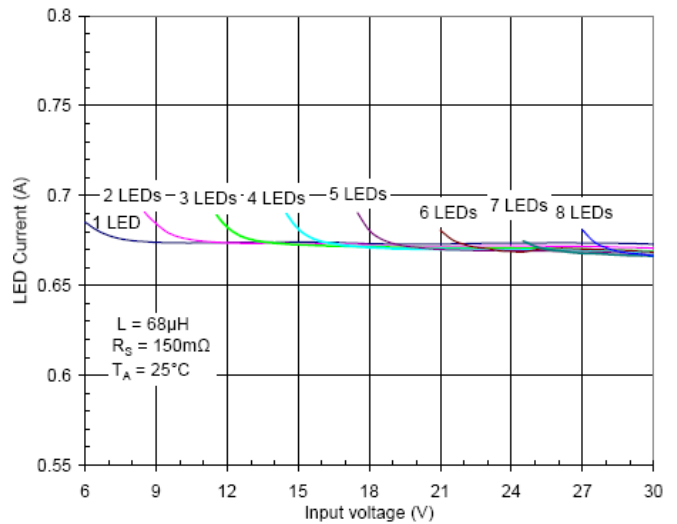

Figure 4, 670mA LED Current vs. Input Voltage

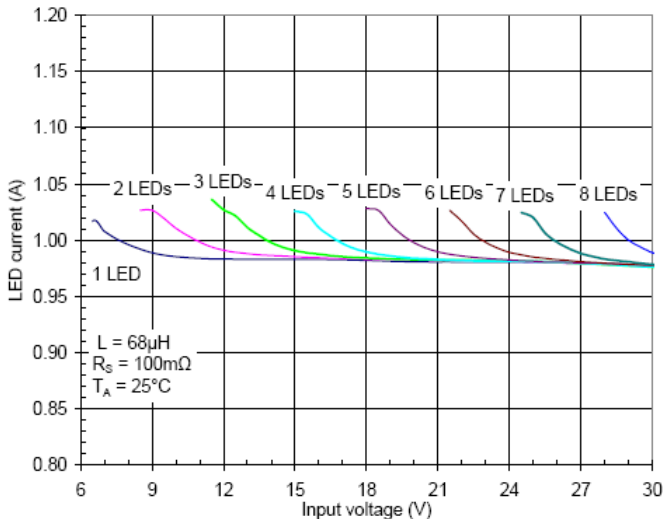

Figure 5, 1A LED Current vs. Input Voltage

## Applications Information

### SD3362 Operation

In normal operation, when voltage is applied at +VIN, the SD3362 internal switch is turned on. Current starts to flow through sense resistor R1, inductor L1, and the LEDs. The current ramps up linearly, and the ramp rate is determined by the input voltage VIN and the inductor L1.

This rising current produces a voltage ramp across R1. The internal circuit of the SD3362 senses the voltage across R1 and applies a proportional voltage to the input of the internal comparator.

When this voltage reaches an internally set upper threshold, the internal switch is turned off. The inductor current continues to flow through R1, L1, the LEDs and the schottky diode D1, and back to the supply rail, but it decays, with the rate of decay determined by the forward voltage drop of the LEDs and the schottky diode.

This decaying current produces a falling voltage at R1, which is sensed by the SD3362. A voltage proportional to the sense voltage across R1 is applied at the input of the internal comparator. When this voltage falls to the internally set lower threshold, the internal switch is turned on again. This switch-on-and-off cycle continues to provide the average LED current set by the sense resistor R1.

### LED Current Control

The LED current is controlled by the resistor R1 in Figure 6.

Connected between VIN and SET the nominal average output current in the LED(s) is defined as:

$$I_{LED} = \frac{V_{THD}}{R_{SET}}$$

If the CTRL pin is driven by an external voltage (higher than 0.4V and lower than 2.5V), the average LED current is:

$$I_{LED} = \frac{V_{CTRL} V_{THD}}{V_{REF} R_{SET}}$$

For example for a desired LED current of 660mA and a default voltage VCTRL=2.5V the resulting resistor is:

$$R_{SET} = \frac{V_{THD} V_{CTRL}}{I_{LED} V_{REF}} \approx \frac{0.1}{0.66} \frac{2.5}{2.5} \approx 150m\Omega$$

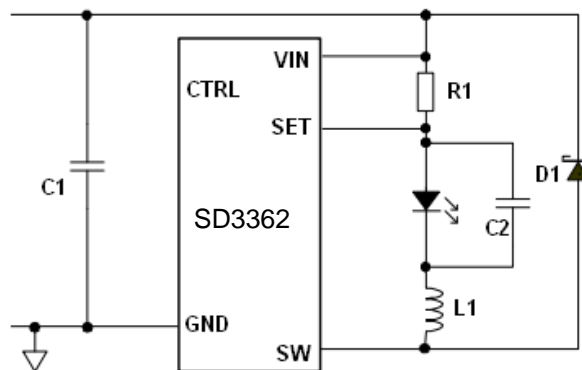

Figure 6, Typical Application Circuit



**DC Dimming**

The CTRL pin can be driven by an external DC voltage ( $V_{CTRL}$ ), to adjust the output current to a value below the nominal average value defined by RSET. The LED current decreases linearly with the CTRL voltage when  $0.5V \leq V_{CTRL} \leq 2.5V$ .

When the  $C_{TRL}$  voltage falls below the threshold, 0.4V, the output switch is turned off which allows PWM dimming.

Note that 100% brightness setting corresponds to  $V_{CTRL} = V_{REF}$ , nominally 2.5V. For any voltage applied on the  $C_{TRL}$  pin that is higher than  $V_{REF}$ , the device will not overdrive the LED current and will still set the current according to the equation  $V_{CTRL} = V_{REF}$ .

**PWM Dimming**

LED current can be adjusted digitally, by applying a low frequency Pulse Width Modulated (PWM) logic signal to the  $C_{TRL}$  pin to turn the device on and off. This will produce an average output current proportional to the duty cycle of the control signal. In particular, a PWM signal with a max resolution of 10bit can be applied to the CTRL pin to change the output current to a value below the nominal average value set by resistor RSET. To achieve this resolution the PWM frequency has to be lower than 500Hz, however higher dimming frequencies can be used, at the expense of dimming dynamic range and accuracy.

Typically, for a PWM frequency of 500Hz the accuracy is better than 1% for PWM ranging from 1% to 100%.

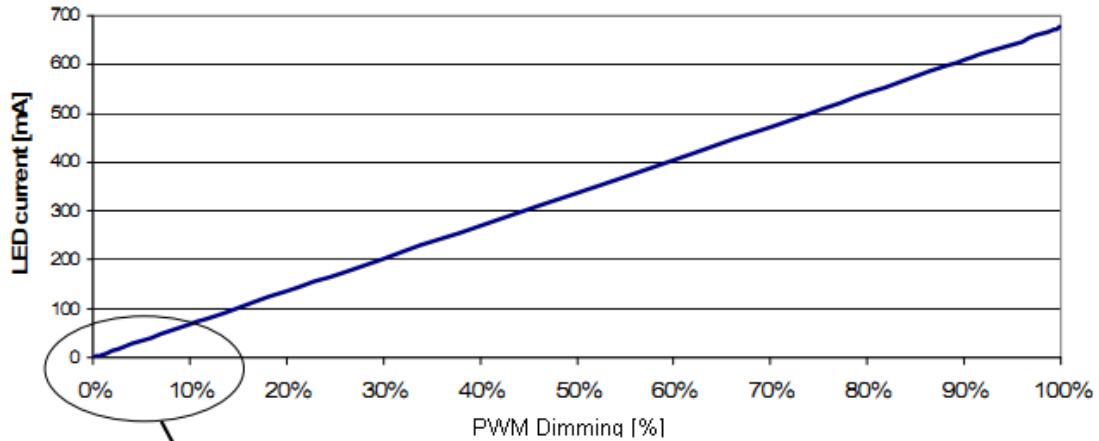

Figure.7 PWM Dimming at 500Hz

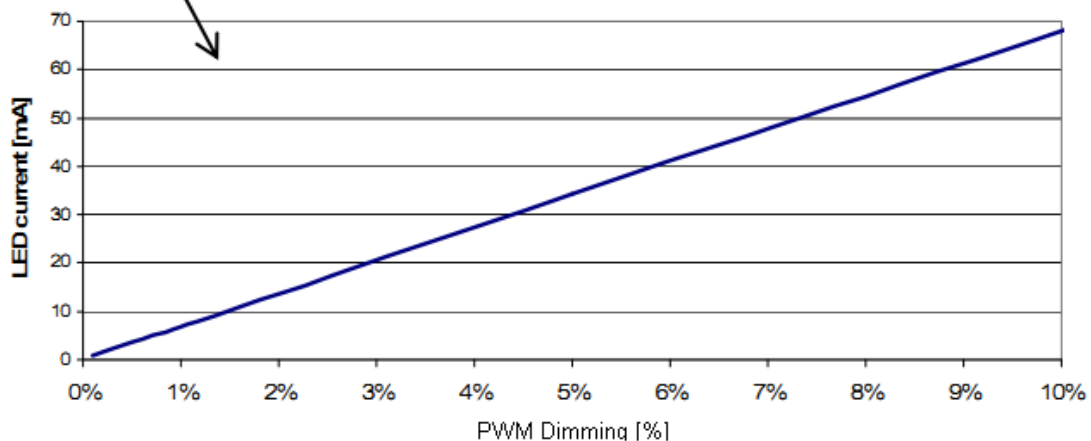

Figure.8 Low duty cycle PWM Dimming at 500Hz



**Reducing output ripple**

Peak to peak ripple current in the LED(s) can be reduced, if required, by shunting a capacitor C2 across the LED(s) as shown already in the circuit schematic.

A value of 1µF will reduce the supply ripple current by a factor three (approx.). Proportionally lower ripple can be achieved with higher capacitor values. Note that the capacitor will not affect operating frequency or efficiency, but it will increase start-up delay, by reducing the rate of rise of LED voltage. By adding this capacitor the current waveform through the LED(s) changes from a triangular ramp to a more sinusoidal version without altering the mean current value.

**Capacitor Selection**

The small size of ceramic capacitors makes them ideal for SD3362 applications. X5R and X7R types are recommended because they retain their capacitance over wider voltage and temperature ranges than other types such as Z5U. A 2.2µF input capacitor is sufficient for most intended applications of SD3362; however a 4.7µF input capacitor is suggested for input voltages approaching 30V.

**Diode Selection**

For maximum efficiency and performance, the rectifier (D1) should be a fast low capacitance Schottky diode with low reverse leakage at the maximum operating voltage and temperature. The Schottky diode also provides better efficiency than silicon PN diodes, due to a combination of lower forward voltage and reduced recovery time. It is important to select parts with a peak current rating above the peak coil current and a continuous current rating higher than the maximum output load current. In particular, it is recommended to have a diode voltage rating at least 15% higher than the operating voltage to ensure safe operation during the switching and a current rating at least 10% higher than the average diode current. The power rating is verified by calculating the power loss through the diode.

Schottky diodes, e.g. SS14 or SS24, with their low forward voltage drop and fast reverse recovery, are the ideal choice for SD3362 applications.

**Applications Information**

Figure.9 Gives details about the PCB layout suggestion:

- 1、 The capacitor C1 has to be placed as close as possible to V<sub>IN</sub>.
- 2、 The sense resistor R1 has to be placed as close as possible to V<sub>IN</sub> and SET.
- 3、 The D1 anode,the SW pin and the inductor have to be placed as close as possible to avoid ringing.

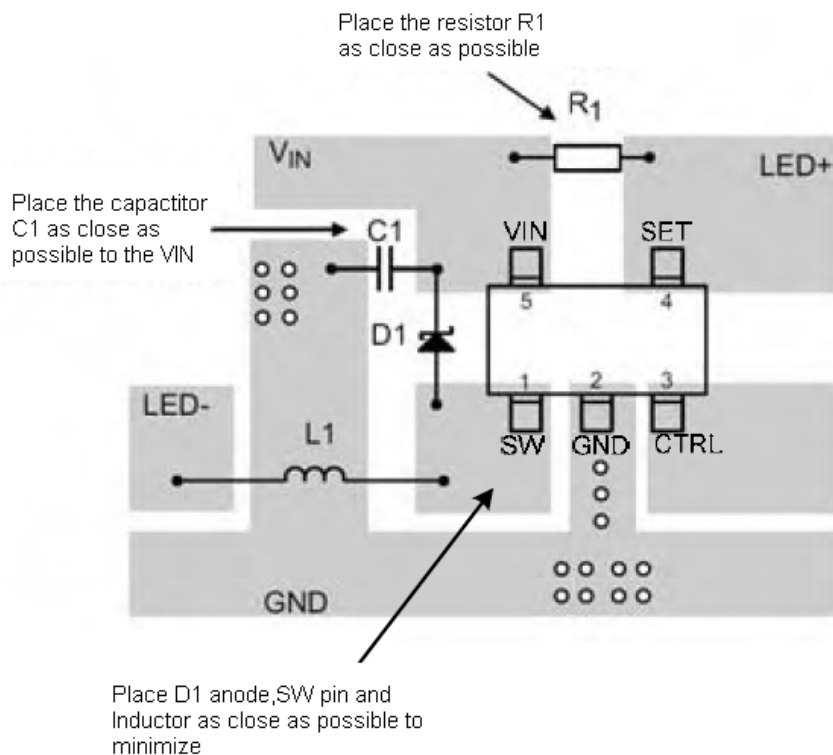

Figure.9 Recommended PCB Layout



**Application Example**

Typical application example for the SD3362 is the MR16 lamp. They typically operate from 12VDC or 12VAC, using conventional electromagnetic transformers or electronic transformers.

As a replacement in some halogen lamp applications LEDs offer a more energy efficient solution – providing no radiated heat and no Ultra Violet light.

This application example is intended to fit into the base connector space of an MR16 style LED lamp.

The design has been optimized for part count and thermal performance for a single 3W LED in the Lens section.

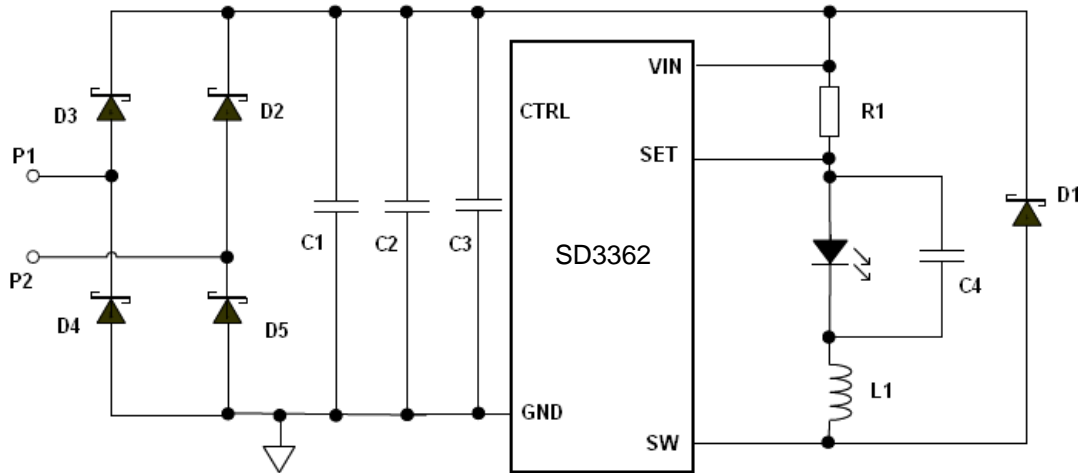

Figure.10 MR16 Schematic

An inductor choice of 33μH with saturation current higher than 1.1A, will limit the frequency variation between 230kHz and 350kHz over the whole input voltage variation (8V to 18V), and therefore represent the best choice for an MR16 solution also taking into account the size constraint of the lamp.

The SD3362 guarantee high level of performance both with 12VAC and 12VDC power supply.

The efficiency is generally higher than 81% and current regulation is better than 0.1mA/V in for a DC input voltage in the range from 8V to 18V.

**Ordering Information**

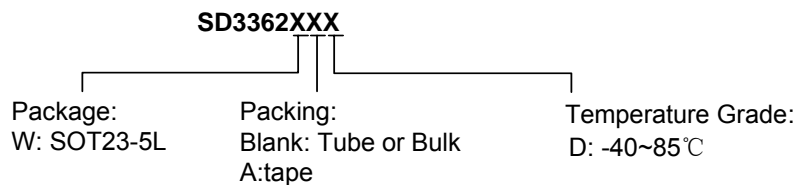

**Marking Information**

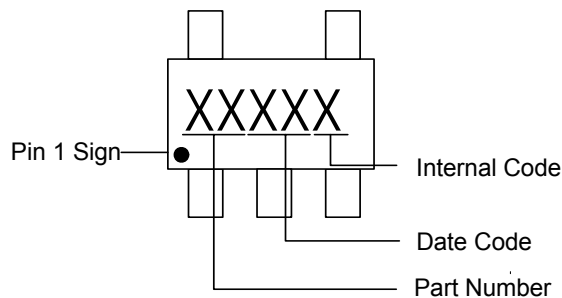





## ■ Package Information

### SOT23-5L

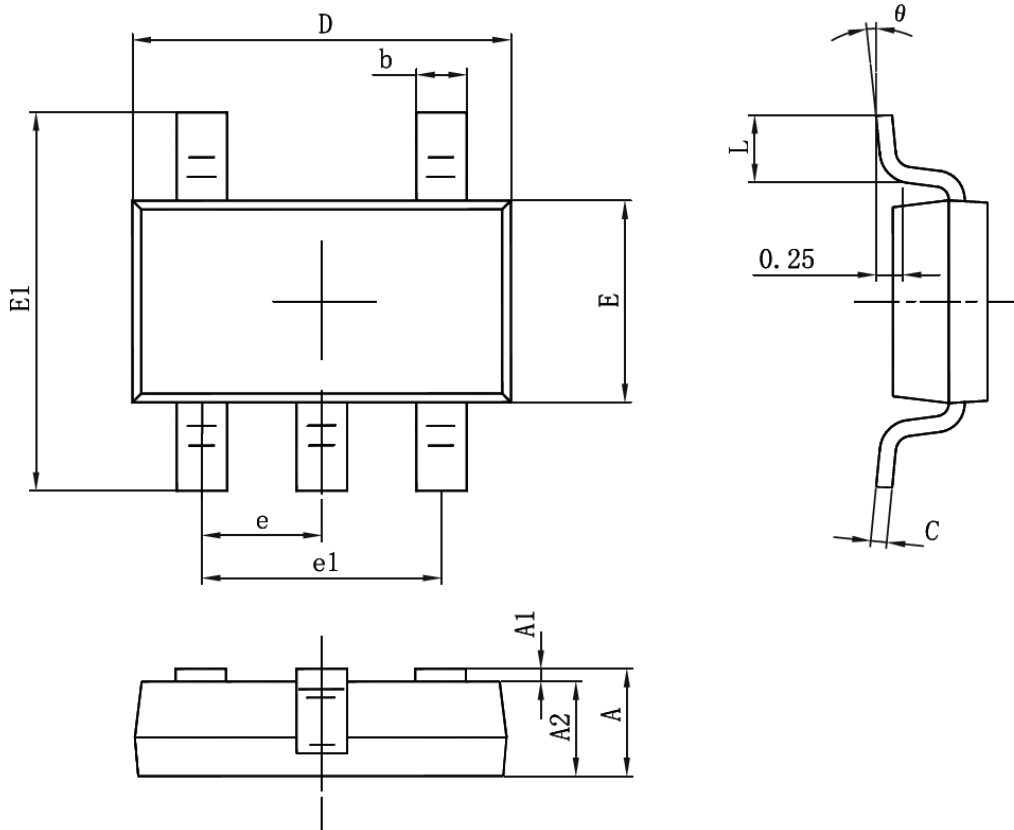

Symbol	Dimensions In Millimeters		Dimensions In Inches	
	Min.	Max.	Min.	Max.
A	1.050	1.250	0.041	0.049
A1	0.000	0.100	0.000	0.004
A2	1.050	1.150	0.041	0.045
b	0.300	0.500	0.012	0.020
c	0.100	0.200	0.004	0.008
D	2.820	3.020	0.111	0.119
E	1.500	1.700	0.059	0.067
E1	2.650	2.950	0.104	0.116
e	0.95(BSC)		0.037(BSC)	
e1	1.800	2.000	0.071	0.079
L	0.300	0.600	0.012	0.024
θ	0°	8°	0°	8°

## X-ON Electronics

Largest Supplier of Electrical and Electronic Components

*Click to view similar products for [LED Display Drivers](#) category:*

*Click to view products by [SHOUDING](#) manufacturer:*

Other Similar products are found below :

[MAP9000QNRH](#) [AP5726WUG-7](#) [AL8806QMP-13](#) [AP5726FDCG-7](#) [AS3693B-ZTQT](#) [AP5725WUG-7](#) [MAX139EQH+D](#) [STP16DP05PTR](#)  
[STP16CPP05PTR](#) [STP16CPP05XTTR](#) [LV5236VZ-TLM-H](#) [BP9911CC](#) [ZXLD1366QEN8TC](#) [MT7725D](#) [TX6143](#) [SY6813PEC](#) [SD1002L4](#)  
[AW3643CSR](#) [MP3370GN-Z](#) [LA2284L-G09-T](#) [SEDA](#) [SCT2027CSSG](#) [LYT3315D](#) [LYT3324D](#) [LYT4211E2](#) [LYT4214E2](#) [LYT4215E2](#)  
[LYT4217E2](#) [LYT4218E2](#) [LYT4222E](#) [LYT4317E2](#) [LYT4321E](#) [LYT4323E](#) [LYT4324E3](#) [LYT4326E3](#) [TPS92020DR](#) [TPS92691PWPR](#)  
[BCR420U](#) [HV9801ALG-G](#) [IS31FL3199-QFLS2-TR](#) [IS31FL3731-QFLS2-TR](#) [CAT4238TD](#) [SCT2001ASIG](#) [SCT2024CSTG](#) [SCT2167CSOG](#)  
[SCT2167CSSG](#) [STP16CPPS05XTTR](#) [TLE4241GMFUMA1](#) [ICM7212MIQH+D](#) [ICM7212AIQH+D](#)