

## Standalone Linear Li-Ion Battery Charger with Thermal Regulation

### Features

- Programmable Charge Current Up to 500mA
- No MOSFET, Sense Resistor or Blocking Diode Required
- Constant-Current/Constant-Voltage Operation with Thermal Regulation to Maximize Charge Rate
- Without Risk of Overheating
- Charges Single Cell Li-Ion Batteries Directly from USB Port
- Preset 4.2V Charge Voltage with 1% Accuracy
- Automatic Recharge
- 2.9V Trickle Charge Threshold
- Available in 6-Lead SOT-23 Package

### Applications

- Charger for Li-Ion Coin Cell Batteries
- Portable MP3 Players, Wireless Headsets
- Bluetooth Applications
- Multifunction Wristwatches

### Description

The SD8003 is a complete constant-current/constant voltage linear charger for single cell lithium-ion batteries. Its package and low external component count make the SD8003 ideally suited for portable applications. Furthermore, the SD8003 is specifically designed to work within USB power specifications.

No external sense resistor is needed, and no blocking diode is required due to the internal MOSFET architecture. The charge voltage is fixed at 4.2V, and the charge current can be programmed externally with a single resistor. The SD8003 automatically terminates the charge cycle when the charge current drops to 1/10<sup>th</sup> the programmed value after the final float voltage is reached.

The SD8003 converters are available in the industry standard SOT-23-6L power packages (or upon request).

### Order Information

SD8003 - ① ② :

SYMBOL	DESCRIPTION
①	Denotes Output voltage: N: 4.2V
②	Denotes Package Types: E: SOT-23-6L

## Typical Application

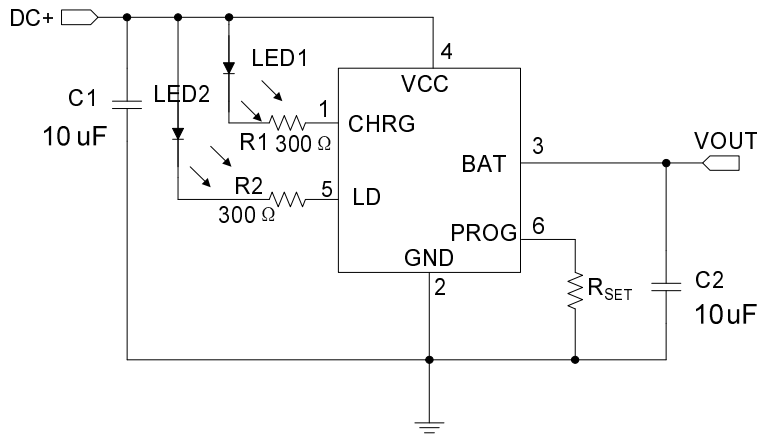

\*  $I_{BAT} = (V_{PROG}/R_{SET}) * 900$

\* When charging in constant-current mode, the  $V_{PROG}$  is usually 1V.

## Pin Assignment

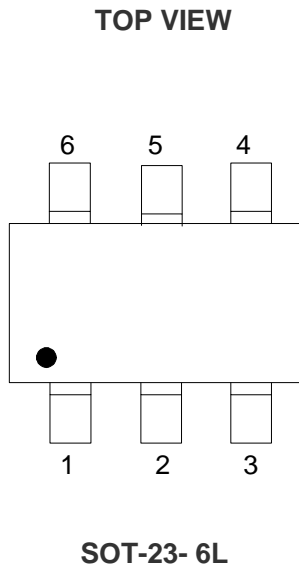

PIN NUMBER SOT-23- 6L	PIN NAME	FUNCTION
1	CHRG	Open-Drain Charge Status Output
2	GND	Ground
3	BAT	Charge Current Output
4	VCC	Positive Input Supply Voltage.
5	LD	Open-Drain Charge Status Output
6	PROG	Charge Current Program

## Pin Description

**CHRG (Pin 1):** Open-Drain Charge Status Output. When the battery is charging, the CHRG pin is pulled low by an internal N-channel MOSFET. When the charge cycle is completed, high impedance is forced to the CHRG pin and LD (pin 5) is pulled low, indicating an “AC present” condition.

**GND (Pin 2):** Ground.

**BAT (Pin 3):** Charge Current Output. It should be bypassed with at least a 1uF capacitor. It Provides charge current to the battery and regulates the final float voltage to 4.2V. An internal precision resistor divider from this pin sets the float voltage which is disconnected in shutdown mode.

**VCC (Pin 4):** Positive Input Supply Voltage. It Provides power to the charger VCC can range from 4.5V to 6V and should be bypassed with at least a 10uf capacitor.

**LD (Pin 5):** Open-Drain Charge Status Output. See CHRG pin (Pin 1).

**PROG (Pin 6):** Charge Current Program, Charge Current Monitor and Shutdown Pin. The charge current is programmed by connecting a 1% resistor, R<sub>PROG</sub>, to ground. When charging in constant-current mode, this pin servos to 1V. In all modes, the voltage on this pin can be used to measure the charge current using the following formula:  $I_{BAT} = (V_{PROG}/R_{SET}) * 900$ .

## Absolute Maximum Ratings (Note 1)

➤ Input Supply Voltage (V <sub>cc</sub> ) .....	-0.3V to 7V
➤ PROG.....	- 0.3V to V <sub>cc</sub> + 0.3V
➤ BAT .....	-0.3V to 7V
➤ CHRG.....	-0.3V to 7V
➤ BAT Pin Current .....	800mA
➤ Maximum Junction Temperature .....	125°C
➤ Operating Ambient Temperature Range (Note 2).....	-40°C to 85°C
➤ Storage Temperature Range .....	-65 °Cto 125°C
➤ Lead Temperature (Soldering, 10 sec).....	300°C

**Note 1:** Absolute Maximum Ratings are those values beyond which the life of the device may be impaired.

**Note 2:** The SD8003 is guaranteed to meet performance specifications from 0°C to 70°C. Specifications over the -40°C to 85°C operating temperature range are assured by design, characterization and correlation with statistical process controls.

## Electrical Characteristics

Operating Conditions:  $T_A=25^{\circ}\text{C}$ ,  $V_{CC}=5\text{V}$  unless otherwise specified.

SYMBOL	PARAMETER	CONDITIONS	MIN	TYP	MAX	UNITS
$V_{CC}$	Input Supply Voltage		4.75	5	6	V
$I_{CC}$	Input Supply Current	Standby Mode (Charge Terminated) I		48		$\mu\text{A}$
		Shutdown Mode ( $R_{PROG}$ Not Connected, $V_{CC} < V_{BAT}$ )		80		$\mu\text{A}$
$V_{FLOAT}$	Regulated Output (Float) Voltage	$0^{\circ}\text{C} \leq T_A \leq 85^{\circ}\text{C}$ , $I_{BAT} = 50\text{mA}$	4.15	4.2	4.24	V
$I_{BAT}$	BAT Pin Current	$R_{PROG} = 10\text{k}$ , Current Mode		90		mA
		$R_{PROG} = 2\text{k}$ , Current Mode		450		mA
		Standby Mode, $V_{BAT} = 4.2\text{V}$		7		$\mu\text{A}$
		Shutdown Mode ( $R_{PROG}$ Not Connected)		13		$\mu\text{A}$
		Sleep Mode, $V_{CC} = 0\text{V}$		0.1		$\mu\text{A}$
$I_{TRIKL}$	Trickle Charge Current	$V_{BAT} < V_{TRIKL}$ , $R_{PROG} = 2\text{k}$		45		mA
$V_{TRIKL}$	Trickle Charge Threshold Voltage	$R_{PROG} = 10\text{k}$ , $V_{BAT}$ Rising		2.9		V
$I_{TERM}$	C/10 Termination Current Threshold	$R_{PROG} = 2\text{k}$		45		mA
$V_{PROG}$	PROG Pin Voltage	$R_{PROG} = 2\text{k}$ , Current Mode		1		V
$\Delta V_{RECHRG}$	Recharge Battery Threshold Voltage	$V_{FLOAT} - V_{RECHRG}$		250		mV
$R_{ON}$		Power FET "ON" Resistance (Between $V_{CC}$ and BAT)		660		m $\Omega$

## Application Information

The SD8003 is a single cell lithium-ion battery charger using a constant-current/constant-voltage algorithm. It can deliver up to 800mA of charge current (using a good thermal PCB layout) with a final float voltage accuracy of  $\pm 1\%$ . The SD8003 includes an internal P-channel power MOSFET and thermal regulation circuitry. No blocking diode or external current sense resistor is required; thus, the basic charger circuit requires only two external components. Furthermore, the SD8003 is capable of operating from a USB power source.

### Normal Charge Cycle

A charge cycle begins when the voltage at the Vcc pin rises above 4.5V and a 1% program resistor is connected from the PROG pin to ground or when a battery is connected to the charger output. If the BAT pin is less than 2.9V, the charger enters trickle charge mode.

In this mode, the SD8003 supplies approximately 1/10 the programmed charge current to bring the battery voltage up to a safe level for full current charging. When the BAT pin voltage rises above 2.9V, the charger enters constant-current mode, where the programmed charge current is supplied to the battery. When the BAT pin approaches the final float voltage (4.2V), the SD8003 enters constant-voltage mode and the charge current begins to decrease. When the charge current drops to 1/10 of the programmed value, the charge cycle ends.

### Charge Termination

A charge cycle is terminated when the charge current falls to 1/10th the programmed value after the final float voltage is reached. This condition is detected by using an internal, filtered comparator to monitor the PROG pin.

When charging, transient loads on the BAT pin can cause the PROG pin to fall below 100mV for short periods of time before the DC charge current has dropped to 1/10th the programmed value. Once the average charge current drops below 1/10th the programmed value, the SD8003 terminates the charge cycle and ceases to provide any current through the BAT pin. In this state, all loads on the BAT pin must be supplied by the battery.

The SD8003 constantly monitors the BAT pin voltage in standby mode. If this voltage drops below the 4V recharge threshold ( $V_{RECHRG}$ ), another charge cycle begins and current is once again supplied to the battery. To manually restart a charge cycle when in standby mode, the input voltage must be removed and reapplied, or the charger must be shut down and restarted using the PROG pin.

### Thermal Limiting

An internal thermal feedback loop reduces the programmed charge current if the die temperature attempts to rise above a preset value of approximately 120° C. This feature protects the SD8003 from excessive temperature and allows the user to push the limits of the power handling capability of a given circuit board without risk of damaging the SD8003. The charge current can be set according to typical (not worst-case) ambient temperature with the assurance that the charger will automatically reduce the current in worst-case conditions. ThinSOT power considerations are discussed further in the Applications Information section.

**Automatic Recharge**

A charge cycle restarts when the battery voltage falls below 4V (which corresponds to approximately 80% to 90% battery capacity). This ensures that the battery is kept at or near a fully charged condition and eliminates the need for periodic charge cycle initiations. CHRG output enters a strong pull down state during recharge cycles.

**VCC Bypass Capacitor**

Many types of capacitors can be used for input bypassing, however, caution must be exercised when using multilayer ceramic capacitors. Because of the self-resonant and high Q characteristics of some types of ceramic capacitors, high voltage transients can be generated under some start-up conditions, such as connecting the charger input to a live power source. Adding a 1.5W resistor in series with an X5R ceramic capacitor will minimize start-up voltage transients.

## Packaging Information

### SOT-23-6L Package Outline Dimension

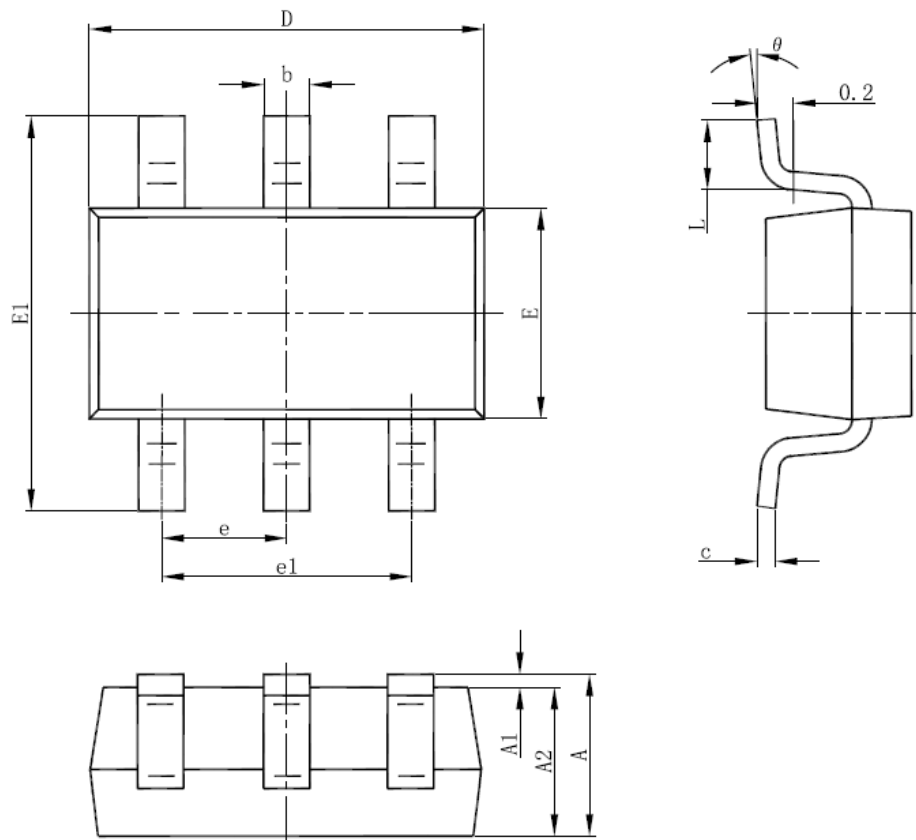

Symbol	Dimensions In Millimeters		Dimensions In Inches	
	Min	Max	Min	Max
A	1.050	1.250	0.041	0.049
A1	0.000	0.100	0.000	0.004
A2	1.050	1.150	0.041	0.045
b	0.300	0.500	0.012	0.020
c	0.100	0.200	0.004	0.008
D	2.820	3.020	0.111	0.119
E	1.500	1.700	0.059	0.067
E1	2.650	2.950	0.104	0.116
e	0.950(BSC)		0.037(BSC)	
e1	1.800	2.000	0.071	0.079
L	0.300	0.600	0.012	0.024

## X-ON Electronics

Largest Supplier of Electrical and Electronic Components

*Click to view similar products for [Battery Management](#) category:*

*Click to view products by [SHOUDING](#) manufacturer:*

Other Similar products are found below :

[MP2602DQ-LF-P](#) [MP26053DQ-LF-Z](#) [MP2611GL-P](#) [NCP347MTAHTBG](#) [LM3658SD-AEV/NOPB](#) [MP2607DL-LF-P](#) [MP26121DQ-LF-P](#)  
[MP26123DR-LF-P](#) [MP2633GR-P](#) [MP2637GR-P](#) [BQ24212EVM-678](#) [NCP1855FCCT1G](#) [MP2636GR-P](#) [FAN54063UCX](#)  
[MAX14680EWC+T](#) [MAX14634EWC+T](#) [DS2745U+T&R](#) [MAX14578EETE+T](#) [DS2781EVKIT+](#) [DS2781E+T&R](#) [MP2605DQ-LF-P](#)  
[DS2710G+T&R](#) [MAX17040G+T](#) [MAX14525ETA+T](#) [MP2615GQ-P](#) [MAX14578EEWC+T](#) [LC05132C01NMTTGTG](#) [MAX8971EWP+T](#)  
[MAX14630EZK+T](#) [MAX1873TEEE+T](#) [PSC5415A](#) [AUR9811DGD](#) [SN2040DSQR](#) [DS2715BZ+T&R](#) [MAX1508ZETA+T](#)  
[MAX14921ECS+T](#) [MAX77301EWA+T](#) [BD8668GW-E2](#) [MAX16024PTBS+T](#) [DS2715Z+T&R](#) [MAX16024LTBZ18+T](#) [DS2782E+T&R](#)  
[DS2782G+T&R](#) [MAX1908ETI+T](#) [ISL95522IRZ](#) [ISL95522HRZ](#) [ARD00558](#) [NCP4371AAEDR2G](#) [BD8665GW-E2](#) [MAX8934EETI+T](#)