

## Standalone Linear Li-Ion Battery Charger with Thermal Regulation

### Features

- Programmable Charge Current Up to 800mA
- No MOSFET, Sense Resistor or Blocking Diode Required
- Complete Linear Charger for Single Cell Lithium-Ion Batteries
- Constant-Current/Constant-Voltage Operation with Thermal Regulation\* to Maximize Charge Rate
- Without Risk of Overheating
- Charges Single Cell Li-Ion Batteries Directly from USB Port
- Preset 4.2V Charge Voltage with 1% Accuracy
- Automatic Recharge
- 65uA Supply Current in Shutdown
- 2.9V Trickle Charge Threshold
- Available in 5-Lead SOT-23 Package

### Applications

- Charger for Li-Ion Coin Cell Batteries
- Portable MP3 Players, Wireless Headsets
- Bluetooth Applications
- Multifunction Wristwatches

### Description

The SD8054 is a complete constant-current/constant voltage linear charger for single cell lithium-ion batteries. Its package and low external component count make the SD8054 ideally suited for portable applications. Furthermore, the SD8054 is specifically designed to work within USB power specifications.

No external sense resistor is needed, and no blocking diode is required due to the internal MOSFET architecture. Thermal feedback regulates the charge current to limit the die temperature during high power operation or high ambient temperature. The charge voltage is fixed at 4.2V, and the charge current can be programmed externally with a single resistor. The SD8054 automatically terminates the charge cycle when the charge current drops to 1/10<sup>th</sup> the programmed value after the final float voltage is reached.

The SD8054 converters are available in the industry standard SOT-23-5 power packages (or upon request).

### Order Information

SD8054 - ① ②:

SYMBOL	DESCRIPTION
①	Denotes Output voltage: 4.2V
②	Denotes Package Types: E: SOT-23-5

Typical Application

600mA Single Cell Li-Ion Charger

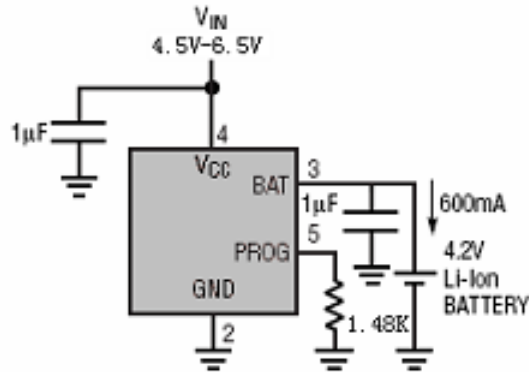

Complete Charge Cycle (750mAh Battery)

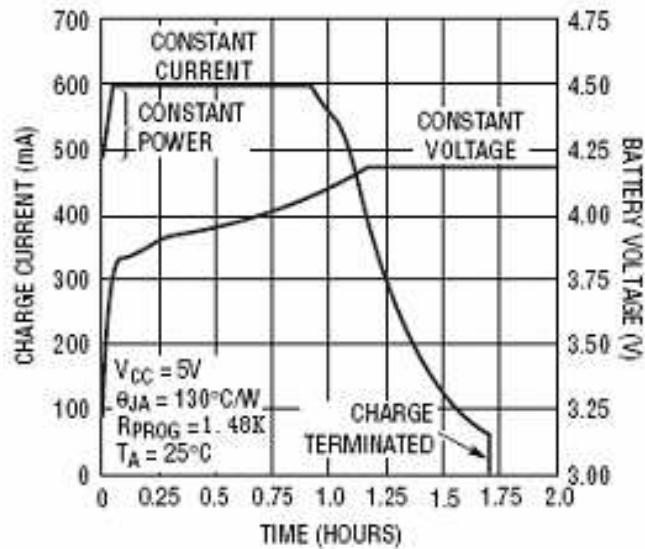

## Pin Assignment

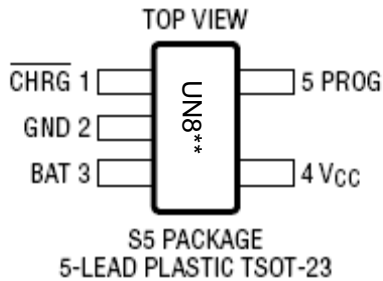

PIN NUMBER SOT-23- 5	PIN NAME	FUNCTION
1	CHRG	Open-Drain Charge Status Output
2	GND	Ground
3	BAT	Charge Current Output
4	V <sub>CC</sub>	Positive Input Supply Voltage.
5	PROG	Charge Current Program, Charge Current Monitor and Shutdown Pin

## Absolute Maximum Ratings

- Input Supply Voltage (VCC) ..... -0.3V to 7V
- PROG..... - 0.3V to VCC + 0.3V
- BAT ..... -0.3V to 7V
- CHRG..... -0.3V to 7V
- BAT Short-Circuit Duration ..... Continuous
- BAT Pin Current ..... 800mA
- Maximum Junction Temperature ..... 125°C
- Operating Ambient Temperature Range..... -40°C to 85°C
- Storage Temperature Range ..... -65 °C to 125°C
- Lead Temperature (Soldering, 10 sec)..... 300°C

## Electrical Characteristics

Operating Conditions:  $T_A=25^{\circ}\text{C}$ ,  $V_{CC}=5\text{V}$  unless otherwise specified.

SYMBOL	PARAMETER	CONDITIONS	MIN	TYP	MAX	UNITS
$V_{CC}$	Input Supply Voltage		4.5	5.0	6.5	V
$I_{CC}$	Input Supply Current	Charge Mode , $R_{PROG} = 10\text{k}$ Standby Mode (Charge Terminated) I Shutdown Mode ( $R_{PROG}$ Not Connected, $V_{CC} < V_{BAT}$ , or $V_{CC} < V_{UV}$ )		70 45 65		$\mu\text{A}$ $\mu\text{A}$ $\mu\text{A}$
$V_{FLOAT}$	Regulated Output (Float) Voltage	$0^{\circ}\text{C} \leq T_A \leq 85^{\circ}\text{C}$ , $I_{BAT} = 50\text{mA}$	4.15	4.2	4.24	V
$I_{BAT}$	BAT Pin Current	$R_{PROG} = 10\text{k}$ , Current Mode $R_{PROG} = 2\text{k}$ , Current Mode Standby Mode, $V_{BAT} = 4.2\text{V}$ Shutdown Mode ( $R_{PROG}$ Not Connected) Sleep Mode, $V_{CC} = 0\text{V}$	83 410	89 445 7.3 7.2 0.3	97 470	$\text{mA}$ $\text{mA}$ $\mu\text{A}$ $\mu\text{A}$ $\mu\text{A}$
$I_{TRIKL}$	Trickle Charge Current	$V_{BAT} < V_{TRIKL}$ , $R_{PROG} = 2\text{k}$	15	39	65	$\text{mA}$
$V_{ASD}$	$V_{CC} - V_{BAT}$ Lockout Threshold Voltage	$V_{CC}$ from Low to High $V_{CC}$ from High to Low		5 18		$\text{mV}$
$I_{TERM}$	C/10 Termination Current Threshold	$R_{PROG} = 2\text{k}$		45		$\text{mA}$
$V_{PROG}$	PROG Pin Voltage	$R_{PROG} = 10\text{k}$ , Current Mode	0.94	1.02	1.08	V
$R_{ON}$	Efficiency	Power FET "ON" Resistance (Between $V_{CC}$ and $BAT$ )		660		$\text{m}\Omega$

---

## Application Information

### PIN ASSIGNMENT

**CHRG (Pin 1):** Open-Drain Charge Status Output. When the battery is charging, the CHRG pin is pulled low by an internal N-channel MOSFET. When the charge cycle is completed or reverse battery lockout / No AC is detected, CHRG is forced high impedance.

**GND (Pin 2):** Ground.

**BAT (Pin 3):** Charge Current Output. It should be bypassed with at least a 1uF capacitor. It Provides charge current to the battery and regulates the final float voltage to 4.2V. An internal precision resistor divider from this pin sets the float voltage which is disconnected in shutdown mode.

**VCC (Pin 4):** Positive Input Supply Voltage. It Provides power to the charger VCC can range from 4.30V to 6.5V and should be bypassed with at least a 1uF capacitor. When VCC drops to within 20mV of the BAT pin voltage, the SD8054 enters shutdown mode, dropping IBAT to less than 1 uA.

**PROG (Pin 5):** Charge Current Program, Charge Current Monitor and Shutdown Pin. The charge current is programmed by connecting a 1% resistor, RPROG, to ground. When charging in constant-current mode, this pin servos to 1V. In all modes, the voltage on this pin can be used to measure the charge current using the following formula:  $IBAT = (V_{PROG}/R_{PROG}) * 890$ , The PROG pin can also be used to shut down the charger. Disconnecting the program resistor from ground allows a weak current to pull the PROG pin high. When it reaches the 1.21V shutdown threshold voltage, the charger enters shutdown mode, charging stops and the input supply current drops to 65uA. Reconnecting RPROG to ground will return the charger to .normal operation.

## Packaging Information

### SOT-23-5 Package Outline Dimension

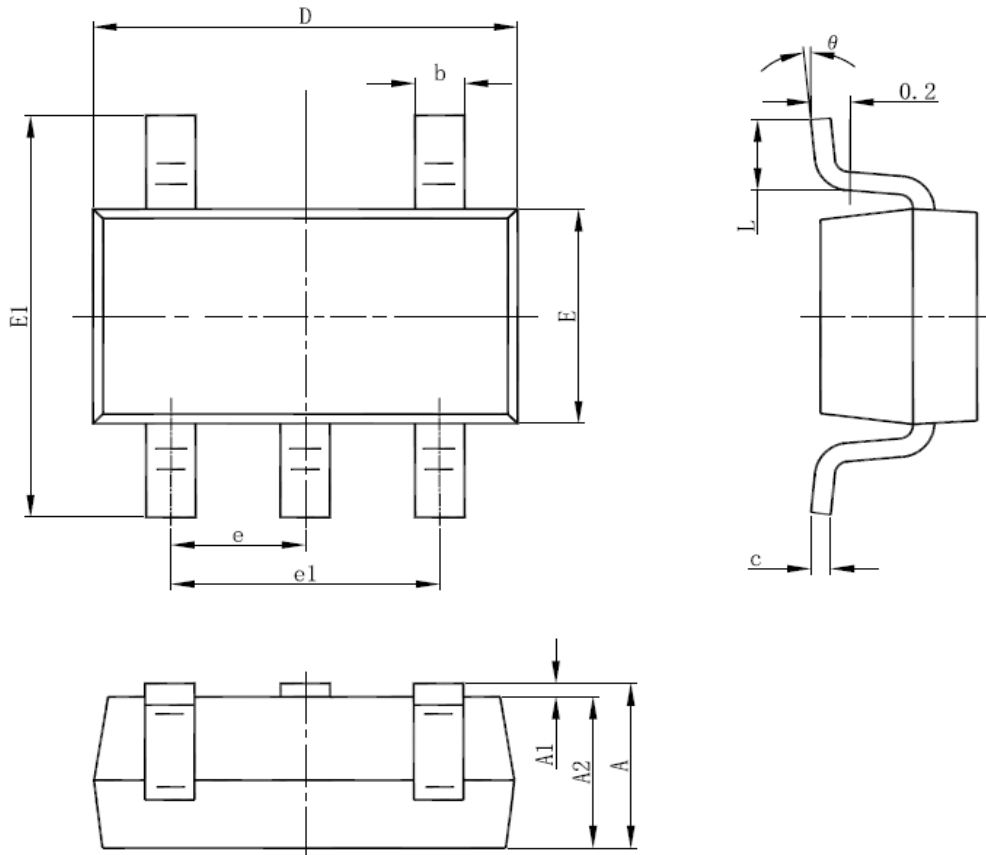

Symbol	Dimensions In Millimeters		Dimensions In Inches	
	Min	Max	Min	Max
A	1.050	1.250	0.041	0.049
A1	0.000	0.100	0.000	0.004
A2	1.050	1.150	0.041	0.045
b	0.300	0.500	0.012	0.020
c	0.100	0.200	0.004	0.008
D	2.820	3.020	0.111	0.119
E	1.500	1.700	0.059	0.067
E1	2.650	2.950	0.104	0.116
e	0.950(BSC)		0.037(BSC)	
e1	1.800	2.000	0.071	0.079
L	0.300	0.600	0.012	0.024

## X-ON Electronics

Largest Supplier of Electrical and Electronic Components

*Click to view similar products for [Battery Management](#) category:*

*Click to view products by [SHOUDING](#) manufacturer:*

Other Similar products are found below :

[MP2602DQ-LF-P](#) [MP26053DQ-LF-Z](#) [MP2611GL-P](#) [NCP347MTAHTBG](#) [LM3658SD-AEV/NOPB](#) [MP2607DL-LF-P](#) [MP26121DQ-LF-P](#)  
[MP26123DR-LF-P](#) [MP2633GR-P](#) [MP2637GR-P](#) [BQ24212EVM-678](#) [NCP1855FCCT1G](#) [MP2636GR-P](#) [FAN54063UCX](#)  
[MAX14680EWC+T](#) [MAX14634EWC+T](#) [DS2745U+T&R](#) [MAX14578EETE+T](#) [DS2781EVKIT+](#) [DS2781E+T&R](#) [MP2605DQ-LF-P](#)  
[DS2710G+T&R](#) [MAX17040G+T](#) [MAX14525ETA+T](#) [MP2615GQ-P](#) [MAX14578EEWC+T](#) [LC05132C01NMTTGTG](#) [MAX8971EWP+T](#)  
[MAX14630EZK+T](#) [MAX1873TEEE+T](#) [PSC5415A](#) [AUR9811DGD](#) [SN2040DSQR](#) [DS2715BZ+T&R](#) [MAX1508ZETA+T](#)  
[MAX14921ECS+T](#) [MAX77301EWA+T](#) [BD8668GW-E2](#) [MAX16024PTBS+T](#) [DS2715Z+T&R](#) [MAX16024LTBZ18+T](#) [DS2782E+T&R](#)  
[DS2782G+T&R](#) [MAX1908ETI+T](#) [ISL95522IRZ](#) [ISL95522HRZ](#) [ARD00558](#) [NCP4371AAEDR2G](#) [BD8665GW-E2](#) [MAX8934EETI+T](#)