

规格书编号

SPEC NO : HDDB05NSBP4SP01

产品规格书

SPECIFICATION

CUSTOMER 客户: _____

PRODUCT 产品: _____ SAW DUPLEXER _____

MODEL NO 型号: _____ HDDB05NSB-P4 _____

MARKING 印字: _____ HD C008 _____

PREPARED 编制: _____ CHECKED 审核: _____

APPROVED 批准: _____ D A T E 日期: _____ 2016-5-3 _____

客户确认 CUSTOMER RECEIVED:		
审核 CHECKED	批准 APPROVED	日期 DATE

无锡市好达电子有限公司
Shoulder Electronics Limited

Factory Address: NO. 115, Gaoyun Road, Binhu Economic & Technology Development Area, Wuxi, Jiangsu, China. Tel: 86-510-85629111
Country of origin: China

更改历史记录 History Record

更改日期 Date	规格书编号 Spec. No.	产品型号 Part No.	客户产品型号 Customer No.	更改内容描述 Modify Content	备注 Remark
2015-7-29	SP00	HDDB05NSB -P4		The new specification	
2016-05-03	SP01	HDDB05NSB -P4		Complete specifications. Add product application, reliability and other information.	

1. Application

- Low-loss Saw duplexer for mobile telephone LTE and WCDMA Band V systems.
- Low insertion attenuation and low passband ripple.
- Usable passband 25MHz
- High isolation between Tx and Rx.
- Single ended to balanced transformation in Antenna - Rx path
- RoHS compatible

2. DIMENSION (PKG SIZE 2.0 x 1.6 x 0.6mm)

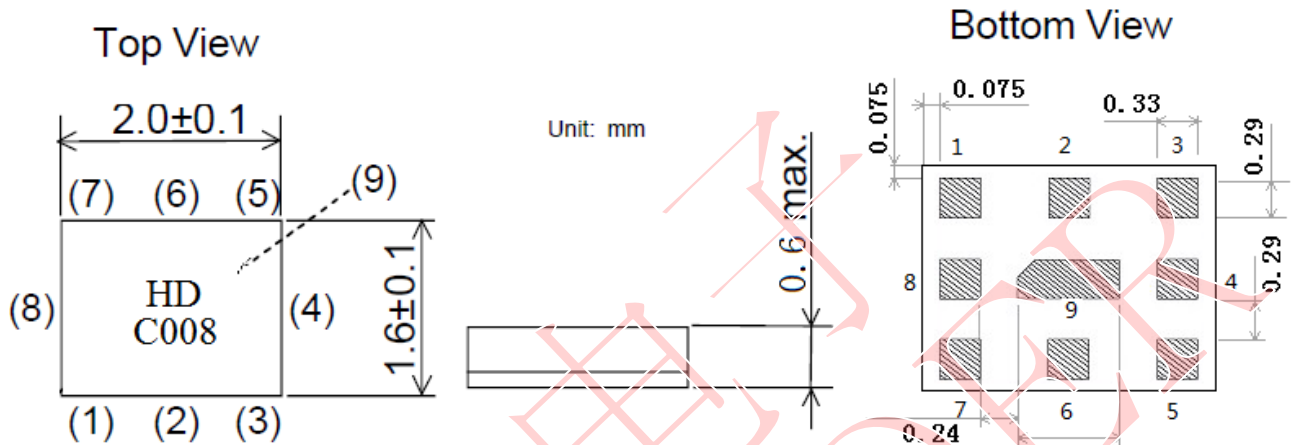

Marking:
 HD: Brand
 C008 : Model code

Pin configuration

- 3. Tx
- 1,8 Rx balanced
- 6. Antenna
- 2,4,5,7 To be grounded

3. Maximum Rating

Items	Conditions
Operation temperature rang	-30℃ ~ +85℃
Storage temperature rang	-40℃ ~ +85℃
ESD voltage	ESD(MM) : 50VDC
Sensitive discharge device	ESD(HBM) : 175VDC
DC Voltage VDC	3V (25+/-2 deg.C)

4. TEST CIRCUIT

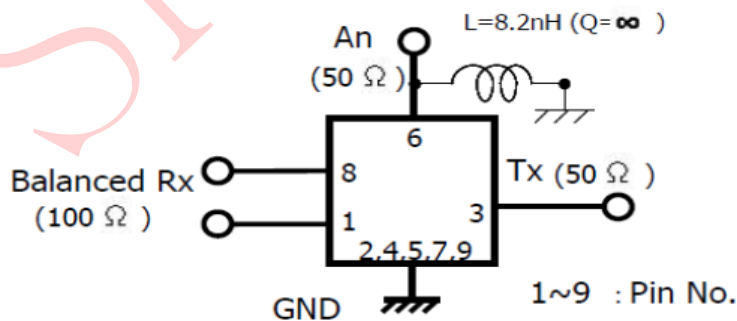

5. ELECTRICAL SPECIFICATION

Table1. Electrical Specification

Item		Condition (MHz)	Specification			Unit	Remarks
			Min	Typ	Max		
TX to ANT	Insertion loss		824~849	-	1.7	2.5	dB
	VSWR	ANT	824~849	-	1.7	2	-
		Tx		-	1.9	2.2	-
	Input Power		824~849	+29dBm Ta=+50°C 5000h,CW			-
	Absolute attenuation		10~420	30	42	-	dB
			420~494	35	40	-	dB
			494~804	30	36	-	dB
			860~869	2	8	-	dB
			869~894	45	53	-	dB
			1574~1577	43	50	-	dB
			1638~1708	35	46	-	dB
			1844.9~1990	30	39	-	dB
			2110~2170	27	37	-	dB
			2400~2557	25	33	-	dB
			3285~3406	20	31	-	dB
		4110~4255	5	14	-	dB	
		4934~5350	3	8	-	dB	
		5725~5953	3	12	-	dB	
ANT to RX	Insertion loss		869~894	-	1.8	2.7	dB
	Phase balance		869~894	-10	-1/+2	10	deg
	Amplitude balance		869~894	-1.0	-0.2/+0.1	1	dB
	VSWR	ANT	869~894	-	1.8	2.1	-
		Rx		-	1.6	2.0	-
	Absolute attenuation		0.2~447	45	85	-	dB
			447~824	30	60	-	dB
			824~849	50	60	-	dB
			849~854	10	54	-	dB
			909~1000	10	18	-	dB
		1000~1850	35	60	-	dB	
		1850~1920	40	60	-	dB	
		1920~4480	35	46	-	dB	

Table2. Electrical Specification

Item		Condition (MHz)	Specification			Unit	Remarks
			Min	Typ	Max		
TX to RX	Isolation	824~849	52	55	-	dB	
		869.7~893.37	48	53	-	dB	
Terminating Impedance		Tx port	50			Ohm	Single-ended
		Rx port	100			Ohm	Differential
		Ant port	50//8.2nH			Ohm	Single-ended
Operating Temperature			-30 to +85			oC	

6. Typical frequency response

Tx to Ant

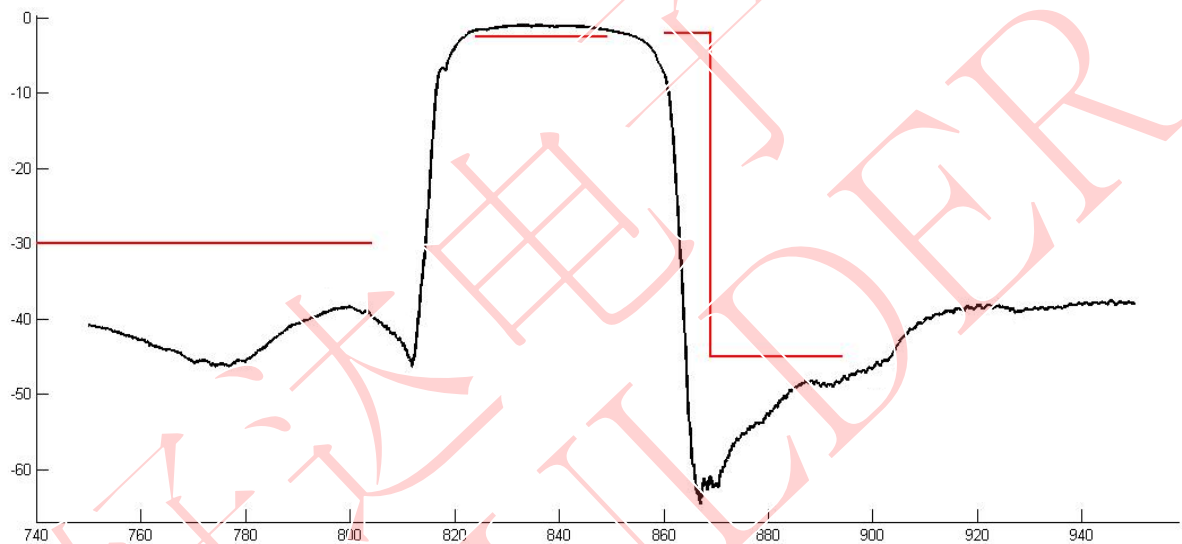

Ant to Rx

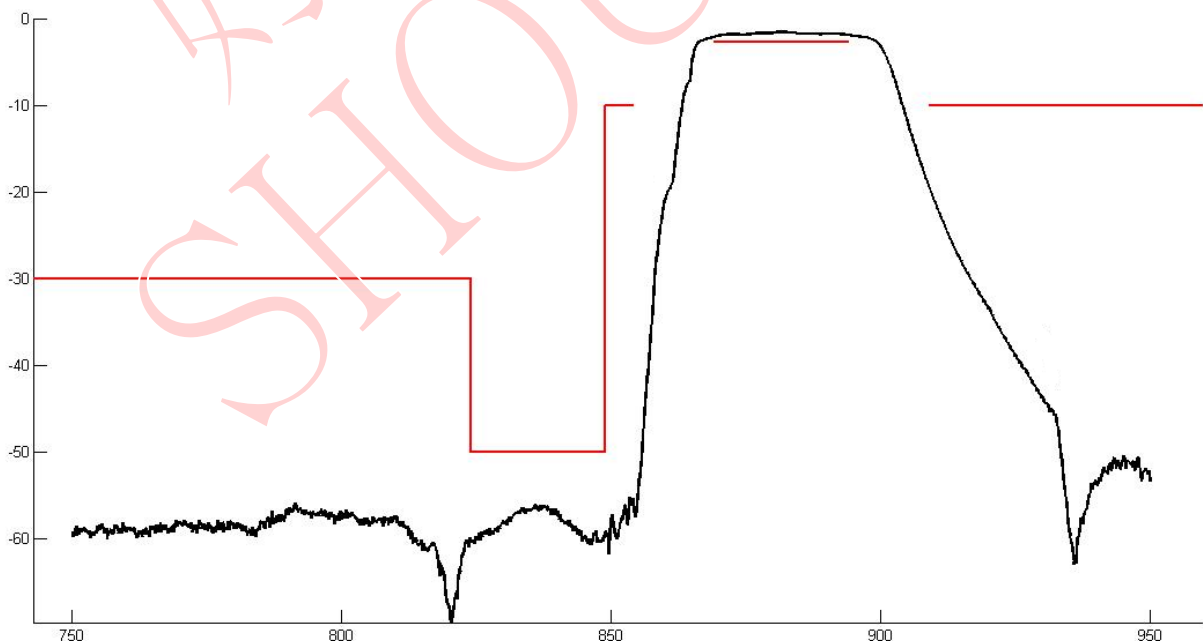

Tx to Rx Isolation

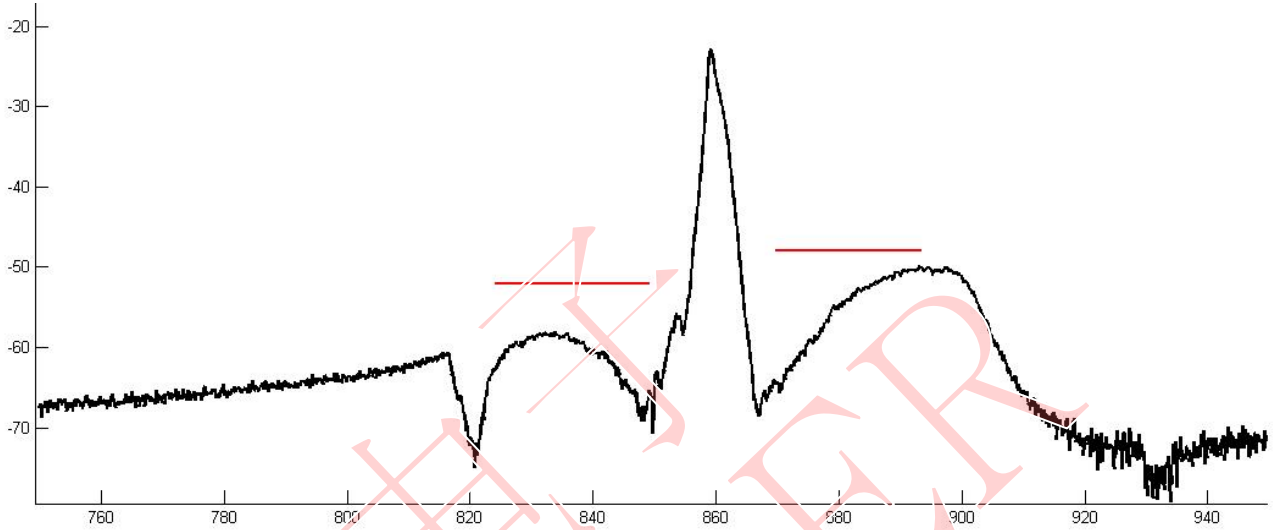

7. ENVIRONMENTAL CHARACTERISTICS

7.1 High temperature exposure

Subject the device to +85°C for 16 hours. Then release the filter into the room conditions for 24 hours prior to the measurement. It shall fulfill the specifications in 5.

7.2 Low temperature exposure

Subject the device to -40°C for 16 hours. Then release the device into the room conditions for 24 hours prior to the measurement. It shall fulfill the specifications in 5.

7.3 Temperature cycling

Subject the device to a low temperature of -40°C for 30 minutes. Following by a high temperature of +85°C for 30 Minutes. Then release the device into the room conditions for 24 hours prior to the measurement. It shall meet the specifications in 5.

7.4 Resistance to solder heat

- 1、immerge the solder bath at 260°C for 10 sec.
- 2、the iron at 370°C for 3 sec

7.5 Solderability

Submerge the device terminals into the solder bath at 245°C ±5°C for 5s, More than 95% area of the soldering pad must be covered with new solder. It shall meet the specifications in 5.

7.6 Reflow soldering

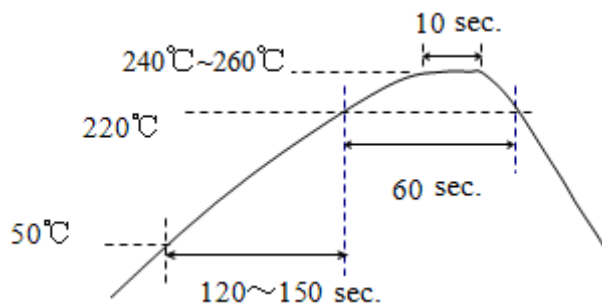

The specimen shall be passed through the reflow furnace with the condition shown in the above profile for 1 time.

The specimen shall be stored at standard atmospheric conditions for 1h, after which the measurement shall be made. Test board shall be 1.6 mm thick. Base material shall be glass fabric base epoxy resin.

7.7 Mechanical shock

Drop the device randomly onto the concrete floor from the height of 1m 3 times. the device shall fulfill the specifications in 5.

7.8 Vibration

Subject the device to the vibration for 1 hour each in x,y and z axes with the amplitude of 1.5 mm at 10 to 55 Hz. The device shall fulfill the specifications in 5.

8. REMARK

8.1 Static voltage

Static voltage between signal load & ground may cause deterioration & destruction of the component. Please avoid static voltage.

8.2 Ultrasonic cleaning

Ultrasonic vibration may cause deterioration & destruction of the component. Please avoid ultrasonic cleaning

8.3 Soldering

Only pad component may be solded. Please avoid soldering another part of component.

9. Packing

9.1 Dimensions

(1) Carrier Tape: Figure 1

(2) Reel: Figure 2

(3) The product shall be packed properly not to be damaged during transportation and storage.

9.2 Reeling Quantity

10000 pcs/reel ϕ 257.5mm

9.3 Taping Structure

(1) The tape shall be wound around the reel in the direction shown below.

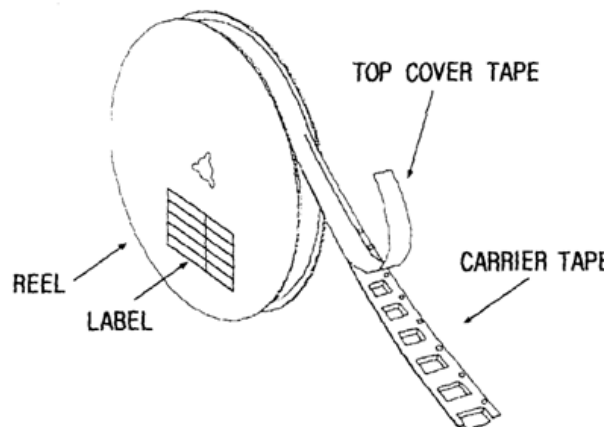

(2) Label

Device Name	
-------------	--

Marking	
User Product Name	
Quantity	
Lot No.	

(3) Leader part and vacant position specifications.

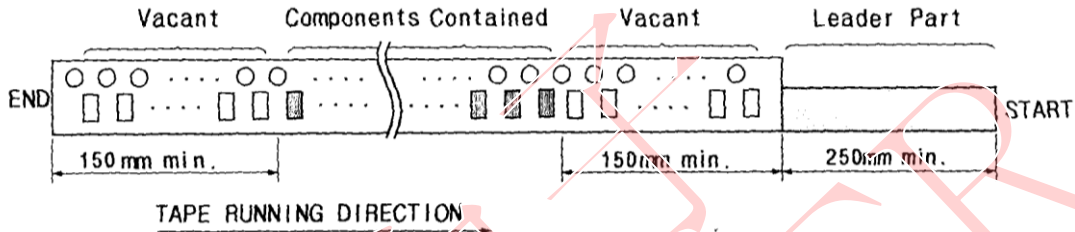

10. TAPE SPECIFICATIONS

10.1 Tensile Strength of Carrier Tape: 4.4N/mm width

10.2 Top Cover Tape Adhesion (See the below figure)

- (1) pull off angle: 0~15°
- (2) speed: 300mm/min.
- (3) force: 20~70g

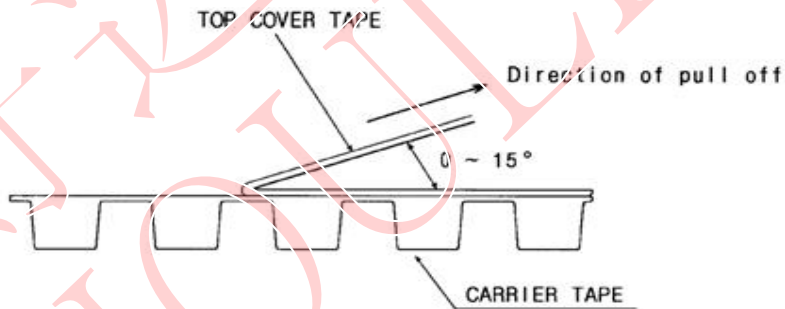

[Figure 1] Carrier Tape Dimensions

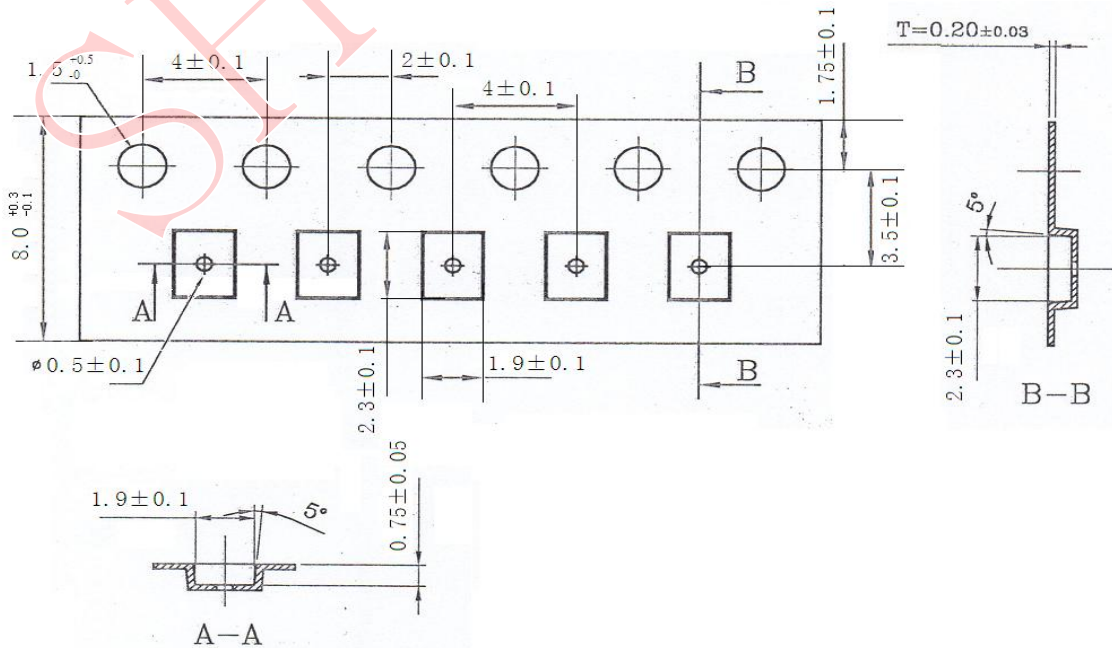

[Figure 2] 10000 pcs/reel ϕ 257.5mm

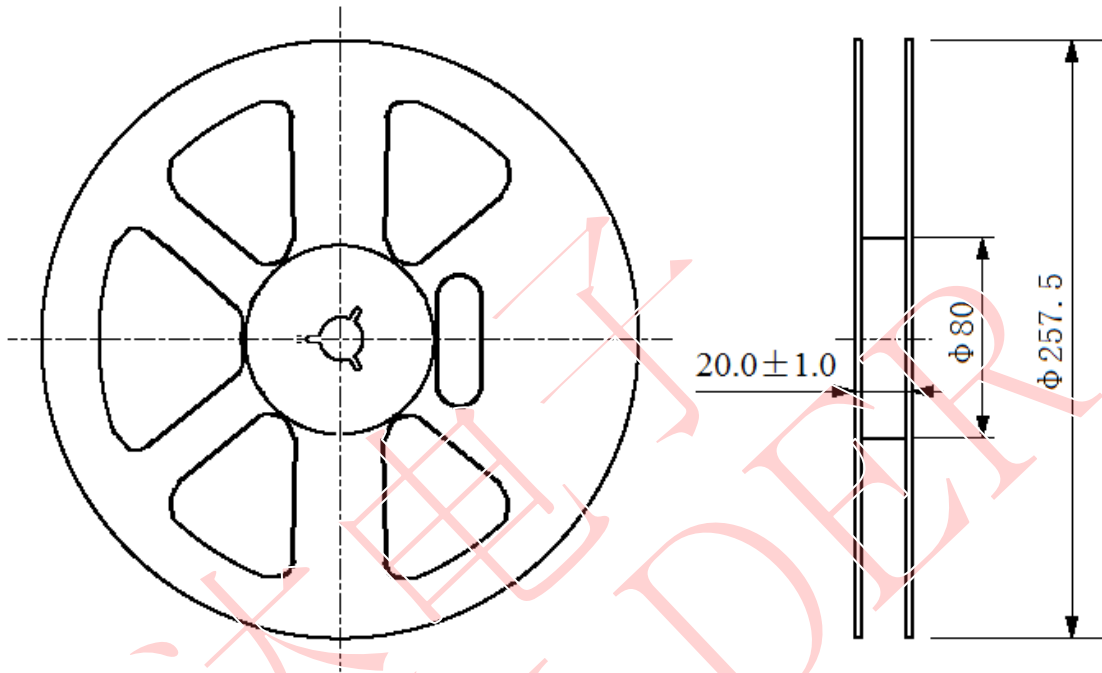

ϕ 257.5 Reel Dimension

(in mm)

X-ON Electronics

Largest Supplier of Electrical and Electronic Components

Click to view similar products for [Signal Conditioning](#) category:

Click to view products by [SHOULDER Electronics](#) manufacturer:

Other Similar products are found below :

[MAPDCC0004](#) [PD0409J5050S2HF](#) [880157](#) [HHS-109-PIN](#) [DC1417J5005AHF](#) [DC4859J5005AHF](#) [AFS14A30-2185.00-T3](#) [AFS14A35-1591.50-T3](#) [DS-323-PIN](#) [DSS-313-PIN](#) [B39321R801H210](#) [B39321R821H210](#) [B39921B4317P810](#) [1A0220-3](#) [2089-6207-00](#) [JP510S](#) [LFB212G45SG8C341](#) [LFB322G45SN1A504](#) [LFL182G45TC3B746](#) [SF2159E](#) [30057](#) [1P510S](#) [CER0813B](#) [3A325](#) [40287](#) [41180](#) [ATB3225-75032NCT](#) [B69842N5807A150](#) [BD0810N50100AHF](#) [BD2326L50200AHF](#) [BD2425J50200AHF](#) [HMC189AMS8TR](#) [C5060J5003AHF](#) [JHS-114-PIN](#) [JP503AS](#) [DC0710J5005AHF](#) [DC2327J5005AHF](#) [DC3338J5005AHF](#) [43020](#) [LFB2H2G60BB1C106](#) [LFL15869MTC1B787](#) [X3C19F1-20S](#) [XC3500P-20S](#) [10013-20](#) [SF2081E](#) [SF2194E](#) [SF2238E](#) [CDBLB455KCAX39-B0](#) [RF1353C](#) [PD0922J5050D2HF](#)